

## LM120/LM320 Series 3-Terminal Negative Regulators

### General Description

The LM120 series are three-terminal negative regulators with a fixed output voltage of  $-5V$ ,  $-12V$ , and  $-15V$ , and up to 1.5A load current capability. Where other voltages are required, the LM137 and LM137HV series provide an output voltage range of  $-1.2V$  to  $-47V$ .

The LM120 need only one external component—a compensation capacitor at the output, making them easy to apply. Worst case guarantees on output voltage deviation due to any combination of line, load or temperature variation assure satisfactory system operation.

Exceptional effort has been made to make the LM120 Series immune to overload conditions. The regulators have current limiting which is independent of temperature, combined with thermal overload protection. Internal current limiting protects against momentary faults while thermal shutdown prevents junction temperatures from exceeding safe limits during prolonged overloads.

Although primarily intended for fixed output voltage applications, the LM120 Series may be programmed for higher output voltages with a simple resistive divider. The low quiescent drain current of the devices allows this technique to be used with good regulation.

### Features

- Preset output voltage error less than  $\pm 3\%$
- Preset current limit
- Internal thermal shutdown
- Operates with input-output voltage differential down to 1V
- Excellent ripple rejection
- Low temperature drift
- Easily adjustable to higher output voltage

### LM120 Series Packages and Power Capability

Device	Package	Rated Power Dissipation	Design Load Current
LM120/LM320	TO-3 (K)	20W	1.5A
	TO-39 (H)	2W	0.5A
LM320	TO-220 (T)	15W	1.5A
LM320M	TO-202 (P)	7.5W	0.5A

### Typical Applications

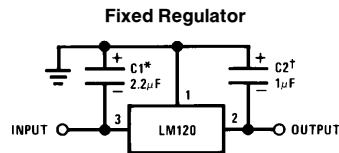
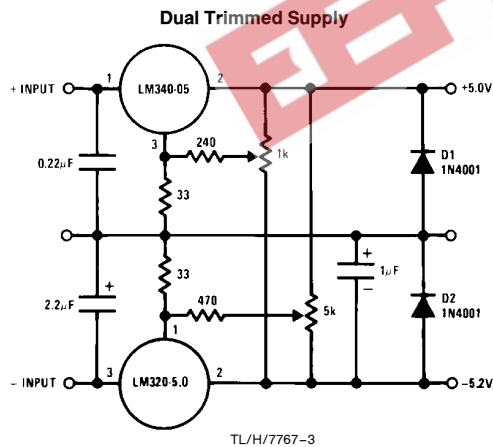

\*Required if regulator is separated from filter capacitor by more than 3". For value given, capacitor must be solid tantalum. 25  $\mu F$  aluminum electrolytic may be substituted.

†Required for stability. For value given, capacitor must be solid tantalum. 25  $\mu F$  aluminum electrolytic may substituted. Values given may be increased without limit.

For output capacitance in excess of 100  $\mu F$ , a high current diode from input to output (1N4001, etc.) will protect the regulator from momentary input shorts.

## —5 Volt Regulators (Note 3)

### Absolute Maximum Ratings

If Military/Aerospace specified devices are required, please contact the National Semiconductor Sales Office/Distributors for availability and specifications. (Note 5)

Power Dissipation Internally Limited  
Input Voltage –25V

Input-Output Voltage Differential 25V  
Junction Temperatures See Note 1  
Storage Temperature Range –65°C to +150°C  
Lead Temperature (Soldering, 10 sec.) 300°C  
Plastic 260°C

### Electrical Characteristics

Parameter	Order Numbers	Metal Can Package												Power Plastic Package						
		LM120K-5.0 (TO-3)				LM320K-5.0 (TO-3)				LM120H-5.0 (TO-39)				LM320H-5.0 (TO-39)						
		Min	Typ	Max	Units	Min	Typ	Max	Units	Min	Typ	Max	Units	Min	Typ	Max	Units			
<b>Design Output Current (I<sub>p</sub>) Device Dissipation (P<sub>D</sub>)</b>		1.5A 20W				1.5A 20W				0.5A 2W				1.5A 15W						
<b>Conditions (Note 1)</b>		T <sub>J</sub> = 25°C, V <sub>IN</sub> = 10V, I <sub>LOAD</sub> = 5 mA																		
Output Voltage		-5.1	-5	-4.9	-5.2	-5	-4.8	-5.1	-5	-4.9	-5.2	-5	-4.8	-5.2	-5	-4.8	-5.2	-5	-4.8	V
Line Regulation		10	25		10	40		10	25		10	40		10	40		10	40		mV
Input Voltage		-25			-7	-25	-7	-25	-7	-25	-7	-25	-7	-25	-7	-25	-7	-25	-7	V
Ripple Rejection		54	64		54	64		54	64		54	64		54	64		54	64		dB
Load Regulation, (Note 2)		50	75		50	100		50	100		50	100		50	100		50	100		mV
Output Voltage, (Note 1)		-5.20	-4.80	-5.25	-5.20	-4.75	-5.20	-5.20	-4.80	-5.20	-4.75	-5.20	-5.20	-4.80	-5.25	-4.75	-5.25	-4.75	-5.25	V
Quiescent Current		1	2		1	2		1	2		1	2		1	2		1	2		mA
Quiescent Current Change		0.1	0.4		0.1	0.4		0.1	0.4		0.1	0.4		0.1	0.4		0.1	0.4		mA
Output Noise Voltage		150			150			150			150			150			150			μV
Long Term Stability		5	50		5	50		5	50		5	50		5	50		5	50		mV
Thermal Resistance Junction to Case		3			3			3			3			3			3			°C/W
Junction to Ambient		35			35			35			35			35			35			°C/W

**Note 1:** This specification applies over -55°C ≤ T<sub>J</sub> ≤ +150°C for the LM120 and 0°C ≤ T<sub>J</sub> ≤ +125°C for the LM320.

**Note 2:** Regulation is measured at constant junction temperature. Changes in output voltage due to heating effects must be taken into account separately. To ensure constant junction temperature, low duty cycle, pulse testing is used. The LM120/LM320 series does have low thermal feedback, improving line and load regulation. On all other tests, even though power dissipation is internally limited, electrical specifications apply only up to P<sub>D</sub>.

**Note 3:** For -5V 3 amp regulators, see LM145 data sheet.

**Note 4:** Thermal resistance of typically 85°C/W (in 400 linear feet air flow), 224°C/W (in static air) junction to ambient, of typically 21°C/W junction to case.

**Note 5:** Refer to RETS120-5H drawing for LM120H-5.0 or RETS120-5K drawing for LM120-5K military specifications.

## — 12 Volt Regulators

### Absolute Maximum Ratings

If Military/Aerospace specified devices are required, please contact the National Semiconductor Sales Office/Distributors for availability and specifications. (Note 4)

Power Dissipation

Internally Limited

Input Voltage

–35V

Input-Output Voltage Differential

30V

Junction Temperatures

See Note 1

Storage Temperature Range

–65°C to +150°C

Lead Temperature (Soldering, 10 sec.)

300°C

### Electrical Characteristics

Parameter	Order Numbers	Metal Can Package												Power Plastic Package									
		LM120K-12 (TO-3)				LM320K-12 (TO-3)				LM120H-12 (TO-39)				LM320H-12 (TO-39)				LM320T-12 (TO-220)					
		1A 20W		1A 20W		1A 20W		1A 20W		0.2A 2W		0.2A 2W		0.2A 2W		1A 15W		1A 15W		1A 15W		1A 15W	
Conditions (Note 1)	Min	Typ	Max	Min	Typ	Max	Min	Typ	Max	Min	Typ	Max	Min	Typ	Max	Min	Typ	Max	Min	Typ	Max	Units	
<b>Design Output Current (I<sub>D</sub>) Device Dissipation (P<sub>D</sub>)</b>																							
Output Voltage	T <sub>J</sub> = 25°C, V <sub>IN</sub> = 17V, I <sub>LOAD</sub> = 5 mA	–12.3	–12	–11.7	–12.4	–12	–11.6	–12.3	–12	–11.7	–12.4	–12	–11.6	–12.4	–12	–11.6	–12.4	–12	–11.6	–12.4	–12	–11.6	V
Line Regulation	T <sub>J</sub> = 25°C, I <sub>LOAD</sub> = 5 mA, V <sub>MIN</sub> ≤ V <sub>IN</sub> ≤ V <sub>MAX</sub>		4	10	4	20		4	10	4	20		4	20		4	20		4	20		20	mV
Input Voltage		–32		–14	–32	–14	–32		–14	–32	–14	–32		–14	–32		–14		–32				V
Ripple Rejection	f = 120 Hz	56	80		56	80		56	80		56	80		56	80		56		56				dB
Load Regulation, (Note 2)	T <sub>J</sub> = 25°C, V <sub>IN</sub> = 17V, 5 mA ≤ I <sub>LOAD</sub> ≤ I <sub>D</sub>		30	80		30	80		30	80		30	80		30	80		30		30			mV
Output Voltage, (Note 1)	14.5V ≤ V <sub>IN</sub> ≤ V <sub>MAX</sub> , 5 mA ≤ I <sub>LOAD</sub> ≤ I <sub>D</sub> , P ≤ P <sub>D</sub>	–12.5		–11.5	–12.6	–11.4	–12.5		–11.5	–12.6	–11.4	–12.5		–11.5	–12.6	–11.4	–12.6		–11.4				V
Quiescent Current	V <sub>MIN</sub> ≤ V <sub>IN</sub> ≤ V <sub>MAX</sub>		2	4		2	4		2	4		2	4		2	4		2		2			mA
Change	T <sub>J</sub> = 25°C V <sub>MIN</sub> ≤ V <sub>IN</sub> ≤ V <sub>MAX</sub> 5 mA ≤ I <sub>LOAD</sub> ≤ I <sub>D</sub>		0.1	0.4		0.1	0.4		0.1	0.4		0.1	0.4		0.1	0.4		0.1		0.1			mA
Output Noise Voltage	T <sub>A</sub> = 25°C, C <sub>L</sub> = 1 μF, I <sub>L</sub> = 5 mA, V <sub>IN</sub> = 17V, 10 Hz ≤ f ≤ 100 kHz		400		400		400		400		400		400		400		400		400				μV
Long Term Stability			12	120		12	120		12	120		12	120		12	120		12		12			mV
Thermal Resistance Junction to Case			3	35		3	35		3	35		3	35		3	35		3		3			°C/W
Junction to Ambient																							°C/W

**Note 1:** This specification applies over –55°C ≤ T<sub>J</sub> ≤ +150°C for the LM120 and 0°C ≤ T<sub>J</sub> ≤ +125°C for the LM320.

**Note 2:** Regulation is measured at constant junction temperature. Changes in output voltage due to heating effects must be taken into account separately. To ensure constant junction temperature, low duty cycle, pulse testing is used. The LM120/LM320 series does have low thermal feedback, improving line and load regulation. On all other tests, even though power dissipation is internally limited, electrical specifications apply only up to P<sub>D</sub>.

**Note 3:** Thermal resistance of typically 85°C/W (in 400 linear feet/min air flow), 224°C/W (in static air) junction to ambient, or typically 21°C/W junction to case.

**Note 4:** Refer to RETS120H-12 drawing for LM120H-12 or RETS120-12K drawing for LM120K-12 military specifications.

## — 15 Volt Regulators

### Absolute Maximum Ratings

If Military/Aerospace specified devices are required, please contact the National Semiconductor Sales Office/Distributors for availability and specifications. (Note 4)

Power Dissipation Internally Limited  
 Input Voltage LM120/LM320 –40V  
 LM320T –35V

Input-Output Voltage Differential 30V  
 Junction Temperatures See Note 1  
 Storage Temperature Range –65°C to +150°C  
 Lead Temperature (Soldering, 10 sec.) 300°C

### Electrical Characteristics

Parameter	Order Numbers	Metal Can Package												Power Plastic Package			
		LM120K-15 (TO-3)			LM320K-15 (TO-3)			LM120H-15 (TO-39)			LM320H-15 (TO-39)			LM320T-15 (TO-220)			
		Min	Typ	Max	Min	Typ	Max	Min	Typ	Max	Min	Typ	Max	Min	Typ	Max	Units
<b>Design Output Current (I<sub>D</sub>) Device Dissipation (P<sub>D</sub>)</b>		<b>Conditions (Note 1)</b>															
Output Voltage		T <sub>J</sub> = 25°C, V <sub>IN</sub> = 20V, I <sub>LOAD</sub> = 5 mA															
Line Regulation		T <sub>J</sub> = 25°C, I <sub>LOAD</sub> = 5 mA, V <sub>MIN</sub> ≤ V <sub>IN</sub> ≤ V <sub>MAX</sub>															
Input Voltage		–35															
Ripple Rejection		f = 120 Hz															
Load Regulation, (Note 2)		T <sub>J</sub> = 25°C, V <sub>IN</sub> = 20V, 5 mA ≤ I <sub>LOAD</sub> ≤ I <sub>D</sub>															
Output Voltage, (Note 1)		17.5V ≤ V <sub>IN</sub> ≤ V <sub>MAX</sub> , 5 mA ≤ I <sub>LOAD</sub> ≤ I <sub>D</sub> , P ≤ P <sub>D</sub>															
Quiescent Current		V <sub>MIN</sub> ≤ V <sub>IN</sub> ≤ V <sub>MAX</sub>															
Quiescent Current Change		T <sub>J</sub> = 25°C V <sub>MIN</sub> ≤ V <sub>IN</sub> ≤ V <sub>MAX</sub> 5 mA ≤ I <sub>LOAD</sub> ≤ I <sub>D</sub>															
Output Noise Voltage		T <sub>A</sub> = 25°C, C <sub>L</sub> = 1 μF, I <sub>L</sub> = 5 mA, V <sub>IN</sub> = 20V, 10 Hz ≤ f ≤ 100 kHz															
Long Term Stability																	
Thermal Resistance Junction to Case		3															
Junction to Ambient		35															

**Note 1:** This specification applies over –55°C ≤ T<sub>J</sub> ≤ +150°C for the LM120 and 0°C ≤ T<sub>J</sub> ≤ +125°C for the LM320.

**Note 2:** Regulation is measured at constant junction temperature. Changes in output voltage due to heating effects must be taken into account separately. To ensure constant junction temperature, low duty cycle, pulse testing is used. The LM120/LM320 series does have low thermal feedback, improving line and load regulation. On all other tests, even though power dissipation is internally limited, electrical specifications apply only up to P<sub>D</sub>.

**Note 3:** Thermal resistance of typically 85°C/W (in 400 linear feet/min air flow), 224°C/W (in static air) junction to ambient, of typically 2°C/W junction to case.

**Note 4:** Refer to RETS120-15H drawing for LM120H-15 or RETS120-15K drawing for LM120K-15 military specifications.

## Typical Performance Characteristics

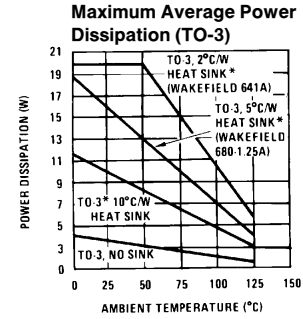
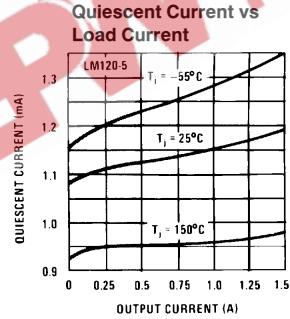
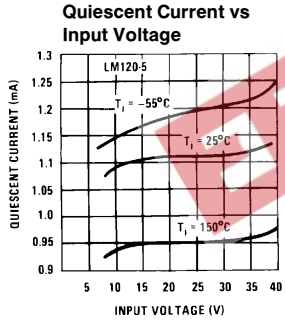
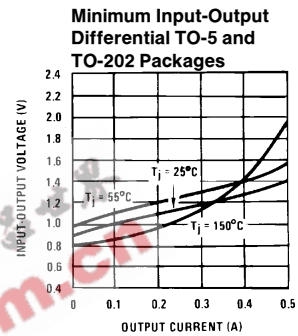
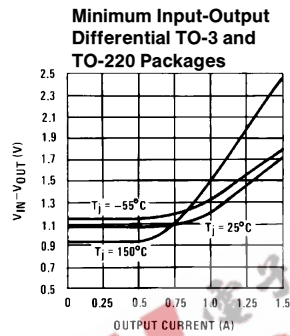
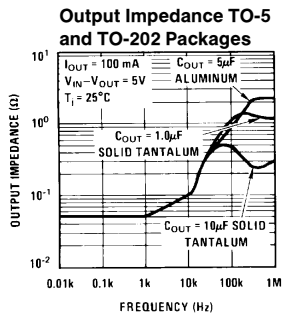
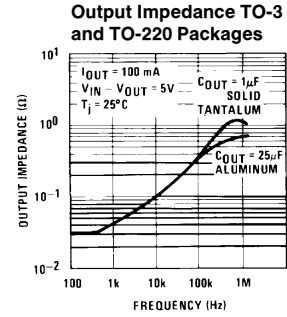
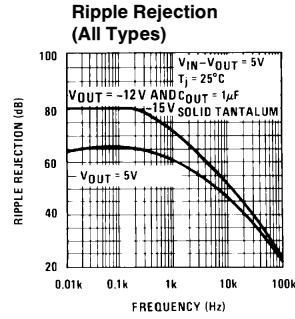
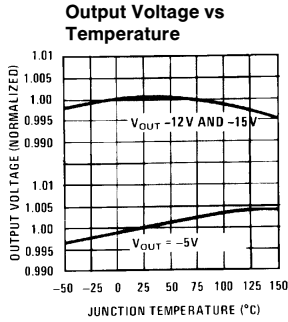

\*These curves for LM120.  
Derate 25°C further for LM320.

TL/H/7767-4

## Typical Performance Characteristics (Continued)

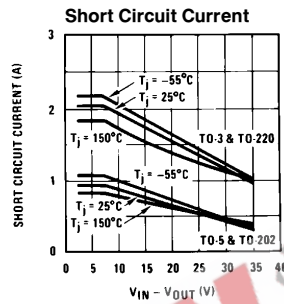
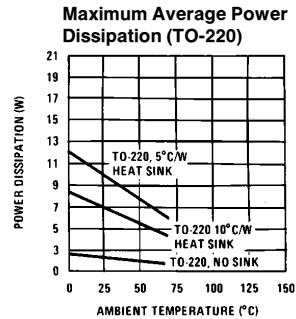
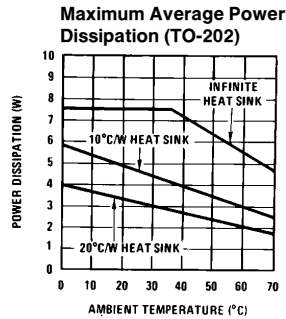
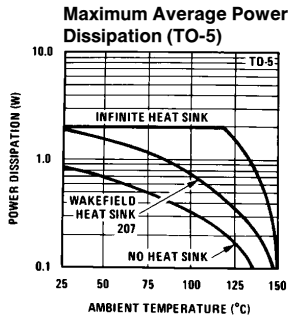

TL/H/7767-5

## Typical Applications (Continued)

### High Stability 1 Amp Regulator

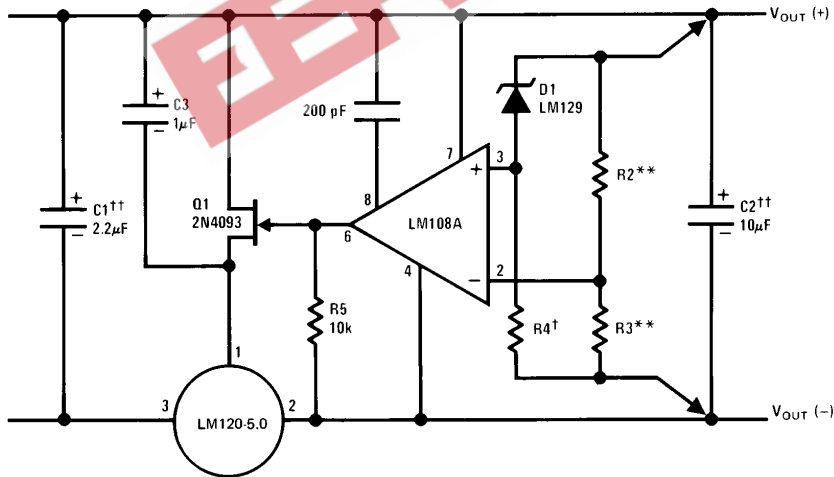

TL/H/7767-6

Lead and line regulation — 0.01% temperature stability — 0.2%

†Determines Zener current.

††Solid tantalum.

An LM120-12 or LM120-15 may be used to permit higher input voltages, but the regulated output voltage must be at least  $-15\text{V}$  when using the LM120-12 and  $-18\text{V}$  for the LM120-15.

\*\*Select resistors to set output voltage. 2 ppm/°C tracking suggested.

## Typical Applications (Continued)

### Wide Range Tracking Regulator

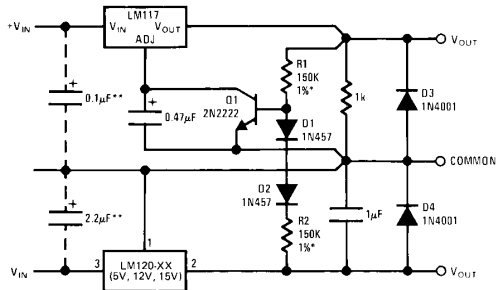

TL/H/7767-7

\*Resistor tolerance of R1 and R2 determine matching of (+) and (-) inputs.

\*\*Necessary only if raw supply capacitors are more than 3" from regulators. An LM3086N array may substitute for Q1, D1 and D2 for better stability and tracking. In the array diode transistors Q5 and Q4 (in parallel) make up D2; similarly, Q1 and Q2 become D1 and Q3 replaces the 2N2222.

### Variable Output

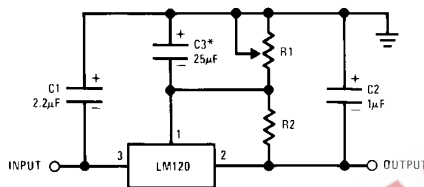

TL/H/7767-9

\*Optional. Improves transient response and ripple rejection.

$$V_{OUT} = V_{SET} \frac{R1 + R2}{R2}$$

SELECT R2 AS FOLLOWS:

LM120-5	- 300Ω
LM120-12	- 750Ω
LM120-15	- 1k

### Current Source

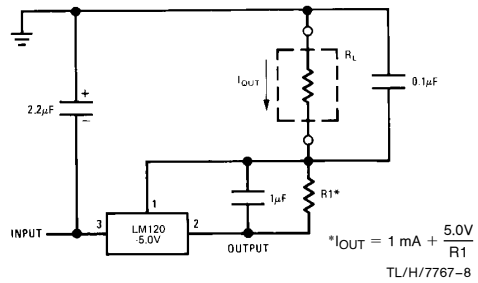

TL/H/7767-8

### ± 15V, 1 Amp Tracking Regulators

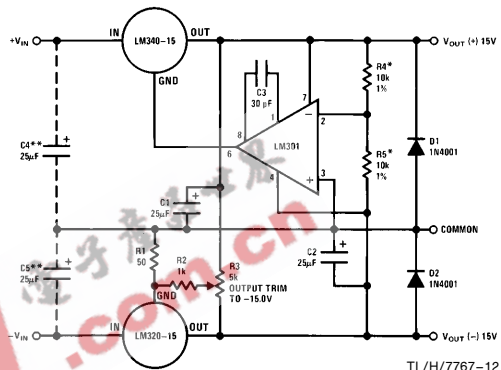

TL/H/7767-12

### Performance (Typical)

Load Regulation at $\Delta I_L = 1A$	10 mV	1 mV
Output Ripple, $C_{IN} = 3000 \mu F, I_L = 1A$	100 $\mu V_{rms}$	100 $\mu V_{rms}$
Temperature Stability	+ 50 mV	+ 50 mV
Output Noise 10 Hz $\leq f \leq 10$ kHz	150 $\mu V_{rms}$	150 $\mu V_{rms}$

\*Resistor tolerance of R4 and R5 determine matching of (+) and (-) outputs.

\*\*Necessary only if raw supply filter capacitors are more than 2" from regulators.

### Light Controllers Using Silicon Photo Cells

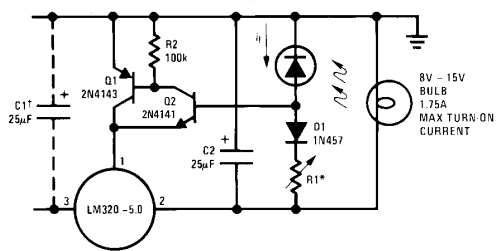

TL/H/7767-10

\*Lamp brightness increases until  $i_i = 5V/R1$  ( $i_i$  can be set as low as 1  $\mu A$ ).

†Necessary only if raw supply filter capacitor is more than 2" from LM320MP.

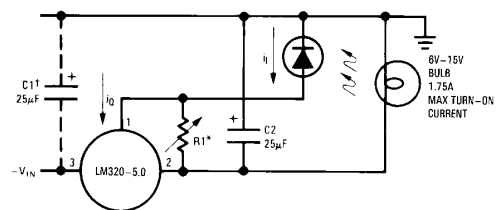

TL/H/7767-11

\*Lamp brightness increases until  $i_i = i_Q$  (1 mA) + 5V/R1.

†Necessary only if raw supply filter capacitor is more than 2" from LM320.

## Connection Diagrams

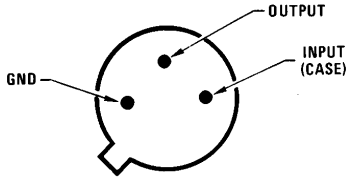

Bottom View

Metal Can Package TO-39 (H)  
 Order Number LM120H-5.0, LM120H-12, LM120H-15,  
 LM120H-5.0/883, LM120H-12/883, LM120H-15/883,  
 LM320H-5.0, LM320H-12 or LM320H-15  
 See NS Package Number H03A

TL/H/7767-13

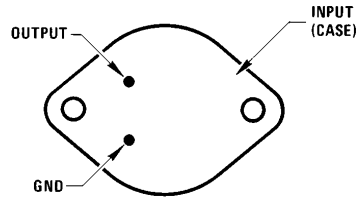

Bottom View

Steel Metal Can Package TO-3 (K)  
 Order Number LM120K-5.0/883, LM120K-12/883,  
 LM120K-15/883, LM320K-5.0, LM320K-12 or LM320K-15  
 See NS Package Number K02A

TL/H/7767-14

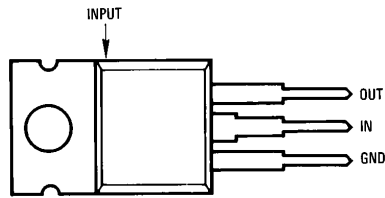

Front View

Power Package TO-220 (T)  
 Order Number LM320T-5.0, LM320T-12 or LM320T-15  
 See NS Package Number T03B

TL/H/7767-17

## Schematic Diagrams

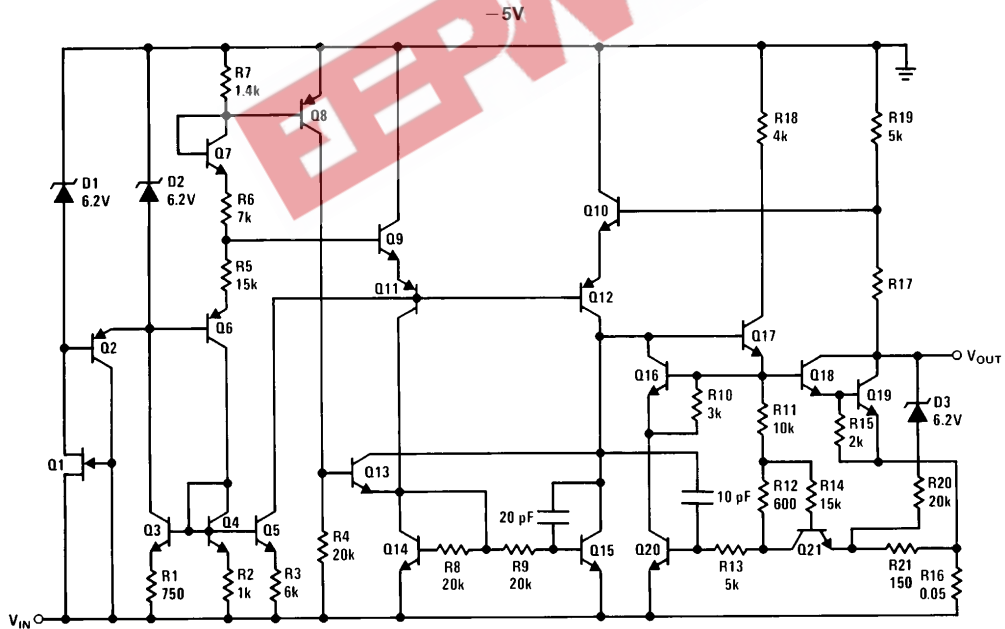

TL/H/7767-18



## Schematic Diagrams (Continued)

- 12V and - 15V

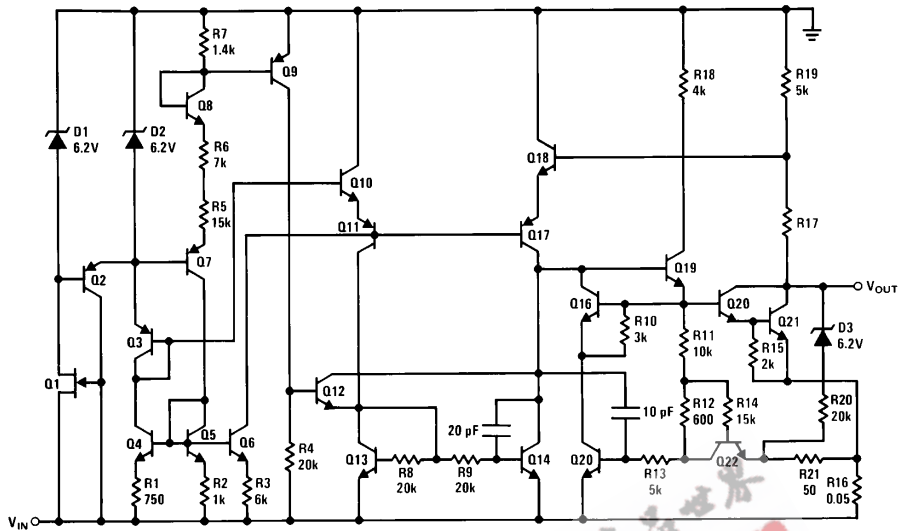

TL/H/7767-19

## Physical Dimensions inches (millimeters)

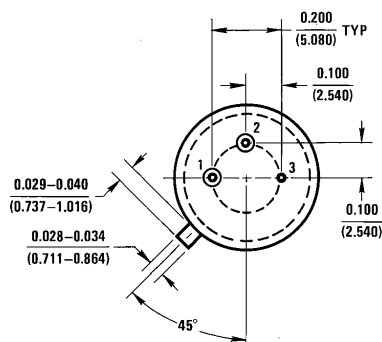
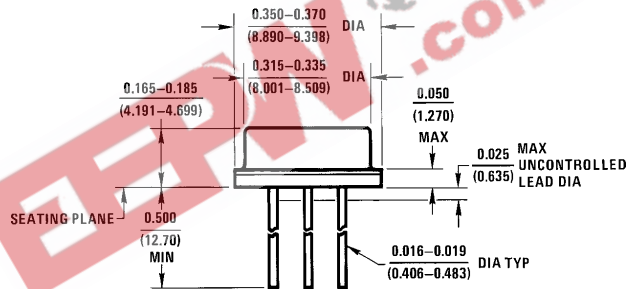

H03A (REV B)

Metal Can Package (TO-39) (H)

Order Number LM120H-5.0, LM120H-12, LM120H-15, LM320H-5.0, LM320H-12 or LM320H-15  
NS Package Number H03A

**Physical Dimensions** inches (millimeters) (Continued)

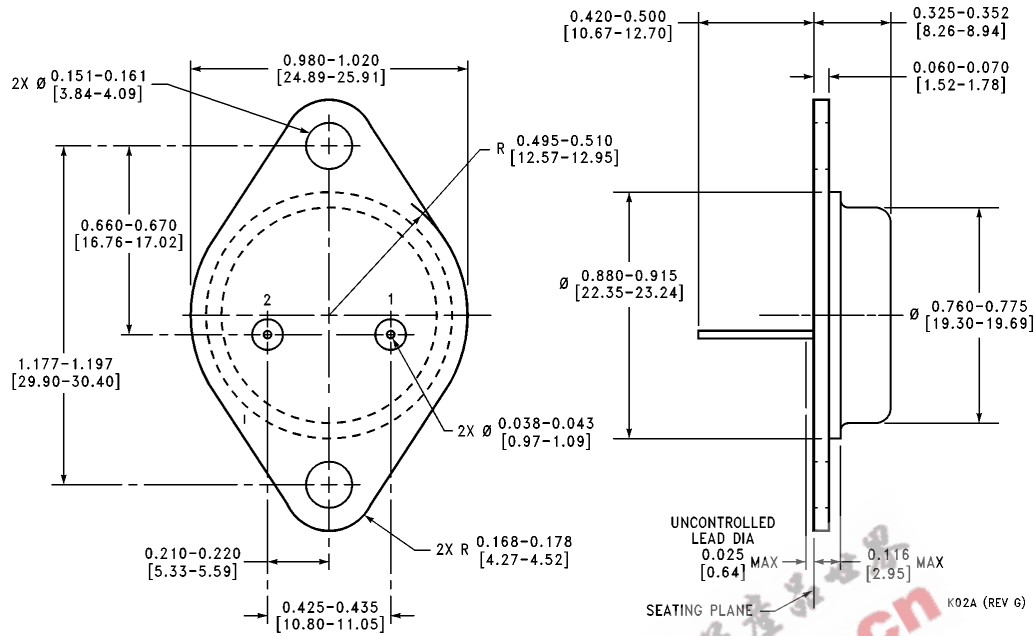

**Steel Metal Can Package TO-3 (K)**  
**Order Number LM120K-5.0, LM120K-12, LM120K-15, LM320K-5.0, LM320K-12 or LM320K-15**  
**NS Package Number K02A**

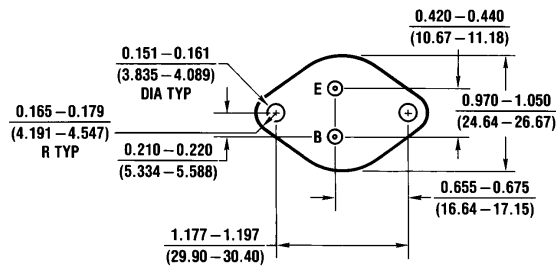
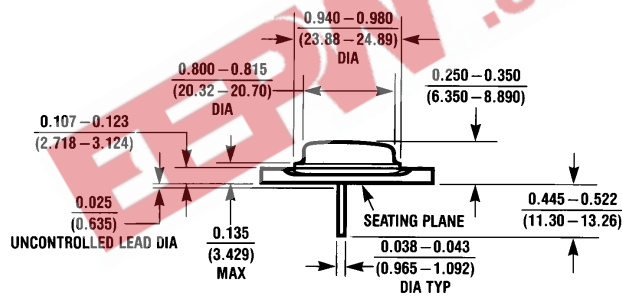

**Aluminum Metal Can Package TO-3 (KC)**  
**Order Number LM320KC-5.0, LM320KC-12 or LM320KC-15**  
**NS Package Number KC02A**

**Physical Dimensions** inches (millimeters) (Continued)

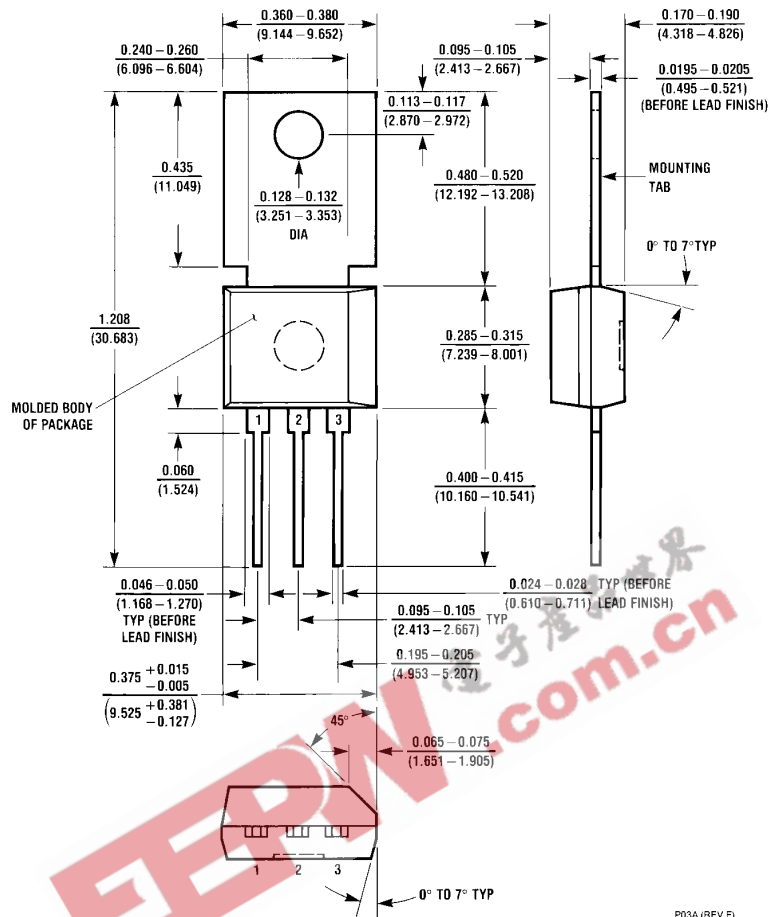

**Power Package TO-202 (P)**  
**Order Number LM320MP-5.0, LM320MP-12 or LM320MP-15**  
**NS Package Number P03A**

P03A (REV F)

**Physical Dimensions** inches (millimeters) (Continued)

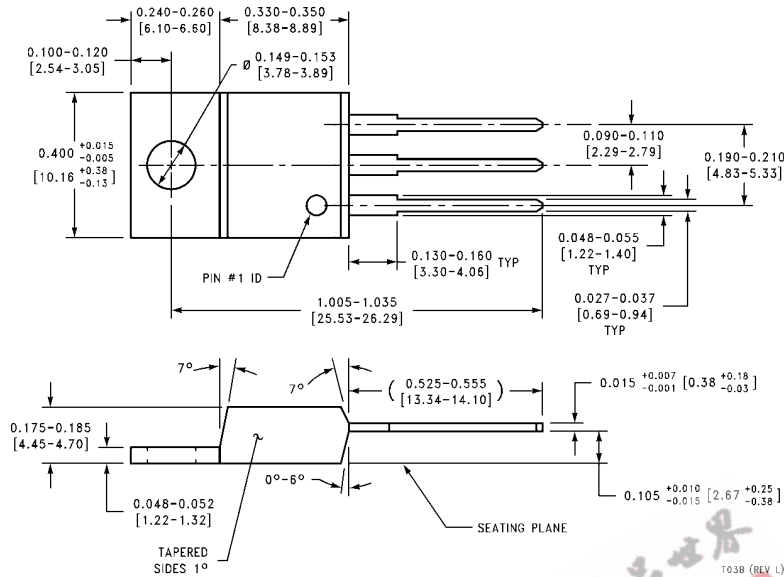

**Power Package TO-220 (T)**  
**Order Number LM320T-5.0, LM320T-12 or LM320T-15**  
**NS Package Number T03B**

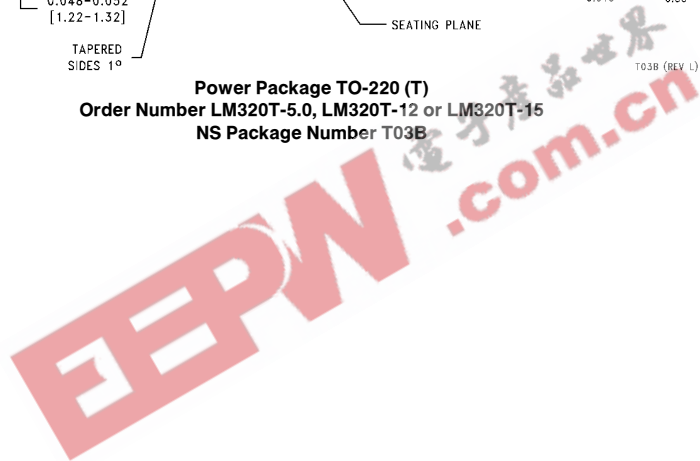

**LIFE SUPPORT POLICY**

NATIONAL'S PRODUCTS ARE NOT AUTHORIZED FOR USE AS CRITICAL COMPONENTS IN LIFE SUPPORT DEVICES OR SYSTEMS WITHOUT THE EXPRESS WRITTEN APPROVAL OF THE PRESIDENT OF NATIONAL SEMICONDUCTOR CORPORATION. As used herein:

1. Life support devices or systems are devices or systems which, (a) are intended for surgical implant into the body, or (b) support or sustain life, and whose failure to perform, when properly used in accordance with instructions for use provided in the labeling, can be reasonably expected to result in a significant injury to the user.
2. A critical component is any component of a life support device or system whose failure to perform can be reasonably expected to cause the failure of the life support device or system, or to affect its safety or effectiveness.



**National Semiconductor Corporation**  
 1111 West Bardin Road  
 Arlington, TX 76017  
 Tel: 1(800) 272-9959  
 Fax: 1(800) 737-7018

**National Semiconductor Europe**  
 Fax: (+49) 0-180-590 85 86  
 Email: cnjwge@levm2.nsc.com  
 Deutsch Tel: (+49) 0-180-530 85 85  
 English Tel: (+49) 0-180-532 78 32  
 Français Tel: (+49) 0-180-532 93 58  
 Italiano Tel: (+49) 0-180-534 16 80

**National Semiconductor Hong Kong Ltd.**  
 13th Floor, Straight Block,  
 Ocean Centre, 5 Canton Rd.  
 Tsimshatsui, Kowloon  
 Hong Kong  
 Tel: (852) 2737-1600  
 Fax: (852) 2736-9960

**National Semiconductor Japan Ltd.**  
 Tel: 81-043-299-2309  
 Fax: 81-043-299-2408