

LM123/LM323A/LM323 3-Amp, 5-Volt Positive Regulator

General Description

The LM123 is a three-terminal positive regulator with a preset 5V output and a load driving capability of 3 amps. New circuit design and processing techniques are used to provide the high output current without sacrificing the regulation characteristics of lower current devices.

The LM323A offers improved precision over the standard LM323. Parameters with tightened specifications include output voltage tolerance, line regulation, and load regulation.

The 3 amp regulator is virtually blowout proof. Current limiting, power limiting, and thermal shutdown provide the same high level of reliability obtained with these techniques in the LM109 1 amp regulator.

No external components are required for operation of the LM123. If the device is more than 4 inches from the filter capacitor, however, a 1 μ F solid tantalum capacitor should be used on the input. A 0.1 μ F or larger capacitor may be used on the output to reduce load transient spikes created by fast switching digital logic, or to swamp out stray load capacitance.

An overall worst case specification for the combined effects of input voltage, load currents, ambient temperature, and power dissipation ensure that the LM123 will perform satisfactorily as a system element.

For applications requiring other voltages, see LM150 series adjustable regulator data sheet.

Operation is guaranteed over the junction temperature range -55°C to $+150^{\circ}\text{C}$ for LM123, -40°C to $+125^{\circ}\text{C}$ for LM323A, and 0°C to $+125^{\circ}\text{C}$ for LM323. A hermetic TO-3 package is used for high reliability and low thermal resistance.

Features

- Guaranteed 1% initial accuracy (A version)
- 3 amp output current
- Internal current and thermal limiting
- 0.01 Ω typical output impedance
- 7.5V minimum input voltage
- 30W power dissipation
- P* Product Enhancement tested

Connection Diagram

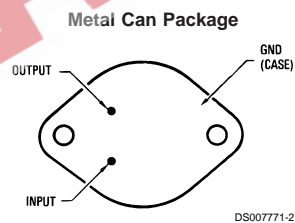

Order Number LM123K STEEL, LM323AK STEEL or LM323K STEEL
 See NS Package Number K02A
 Order Number LM123K/883
 See NS Package Number K02C

Typical Applications

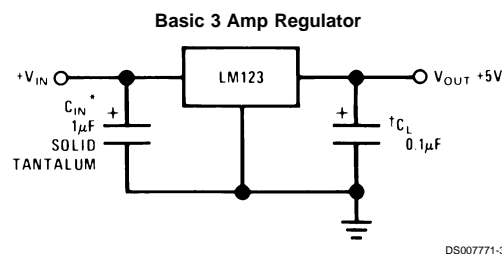

*Required if LM123 is more than 4" from filter capacitor.

†Regulator is stable with no load capacitor into resistive loads.

Absolute Maximum Ratings (Note 1)

If Military/Aerospace specified devices are required, please contact the National Semiconductor Sales Office/Distributors for availability and specifications.

(Note 5)

Input Voltage	20V
Power Dissipation	Internally Limited

Operating Junction Temperature Range

LM123	-55°C to +150°C
LM323A	-40°C to +125°C
LM323	0°C to +125°C

Storage Temperature Range

Lead Temperature (Soldering, 10 sec.)	300°C
ESD Tolerance (Note 5)	2000V

LM123 Electrical Characteristics (Note 2)

Parameter	Conditions	LM123			Units
		Min	Typ	Max	
Output Voltage	$T_j = 25^\circ\text{C}$ $V_{IN} = 7.5\text{V}, I_{OUT} = 0\text{A}$	4.7	5	5.3	V
	$7.5\text{V} \leq V_{IN} \leq 15\text{V}$ $0\text{A} \leq I_{OUT} \leq 3\text{A}, P \leq 30\text{W}$	4.6		5.4	V
Line Regulation (Note 4)	$T_j = 25^\circ\text{C}$ $7.5\text{V} \leq V_{IN} \leq 15\text{V}$		5	25	mV
Load Regulation (Note 4)	$T_j = 25^\circ\text{C}, V_{IN} = 7.5\text{V},$ $0\text{A} \leq I_{OUT} \leq 3\text{A}$		25	100	mV
Quiescent Current	$7.5\text{V} \leq V_{IN} \leq 15\text{V},$ $0\text{A} \leq I_{OUT} \leq 3\text{A}$		12	20	mA
Output Noise Voltage	$T_j = 25^\circ\text{C}$ $10\text{ Hz} \leq f \leq 100\text{ kHz}$		40		μVrms
Short Circuit Current Limit	$T_j = 25^\circ\text{C}$ $V_{IN} = 15\text{V}$ $V_{IN} = 7.5\text{V}$		3	4.5	A
			4	5	A
Long Term Stability				35	mV
Thermal Resistance Junction to Case (Note 3)			2		$^\circ\text{C/W}$

LM323A/LM323 Electrical Characteristics (Note 2)

Parameter	Conditions	LM323A			LM323			Units
		Min	Typ	Max	Min	Typ	Max	
Output Voltage	$T_j = 25^\circ\text{C}$ $V_{IN} = 7.5\text{V}, I_{OUT} = 0\text{A}$	4.95	5	5.05	4.8	5	5.2	V
	$7.5\text{V} \leq V_{IN} \leq 15\text{V}$ $0\text{A} \leq I_{OUT} \leq 3\text{A}, P \leq 30\text{W}$	4.85		5.15	4.75		5.25	V
Line Regulation (Note 4)	$T_j = 25^\circ\text{C}$ $7.5\text{V} \leq V_{IN} \leq 15\text{V}$		5	10		5	25	mV
Load Regulation (Note 4)	$T_j = 25^\circ\text{C}, V_{IN} = 7.5\text{V},$ $0\text{A} \leq I_{OUT} \leq 3\text{A}$		25	50		25	100	mV
Quiescent Current	$7.5\text{V} \leq V_{IN} \leq 15\text{V},$ $0\text{A} \leq I_{OUT} \leq 3\text{A}$		12	20		12	20	mA
Output Noise Voltage	$T_j = 25^\circ\text{C}$ $10\text{ Hz} \leq f \leq 100\text{ kHz}$		40			40		μVrms
Short Circuit Current Limit	$T_j = 25^\circ\text{C}$ $V_{IN} = 15\text{V}$ $V_{IN} = 7.5\text{V}$		3	4.5		3	4.5	A
			4	6		4	5	A
Long Term Stability				35			35	mV
Thermal Resistance Junction to Case (Note 3)			2			2		$^\circ\text{C/W}$

LM323A/LM323 Electrical Characteristics (Note 2) (Continued)

Note 1: "Absolute Maximum Ratings" indicate limits beyond which damage to the device may occur. Operating Ratings indicate conditions for which the device is functional, but do not guarantee specific performance limits.

Note 2: Unless otherwise noted, specifications apply for $-55^{\circ}\text{C} \leq T_j \leq +150^{\circ}\text{C}$ for the LM123, $-40^{\circ}\text{C} \leq T_j \leq +125^{\circ}\text{C}$ for the LM323A, and $0^{\circ}\text{C} \leq T_j \leq +125^{\circ}\text{C}$ for the LM323. Although power dissipation is internally limited, specifications apply only for $P \leq 30\text{W}$.

Note 3: Without a heat sink, the thermal resistance of the TO-3 package is about $35^{\circ}\text{C}/\text{W}$. With a heat sink, the effective thermal resistance can only approach the specified values of $2^{\circ}\text{C}/\text{W}$, depending on the efficiency of the heat sink.

Note 4: Load and line regulation are specified at constant junction temperature. Pulse testing is required with a pulse width $\leq 1\text{ ms}$ and a duty cycle $\leq 5\%$.

Note 5: Refer to RETS123K drawing for LM123K military specifications.

Note 6: Human body model, $1.5\text{ k}\Omega$ in series with 100 pF .

Typical Performance Characteristics

Maximum Average Power Dissipation for LM123

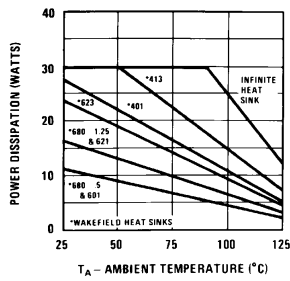

Maximum Average Power Dissipation for LM323A, LM323

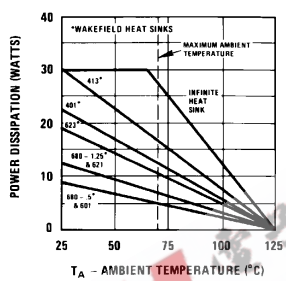

Output Impedance

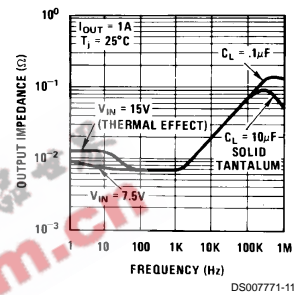

Peak Available Output Current

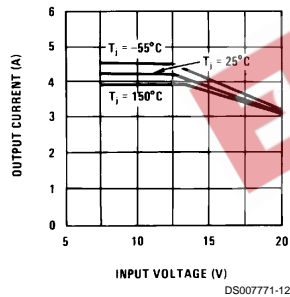

Short Circuit Current

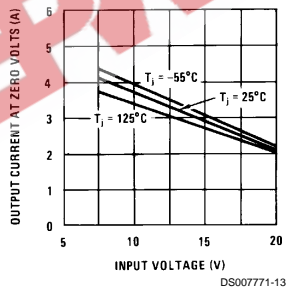

Ripple Rejection

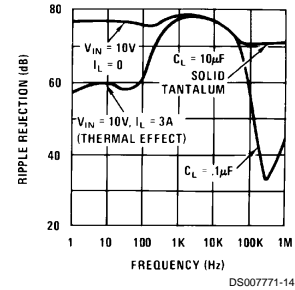

Dropout Voltage

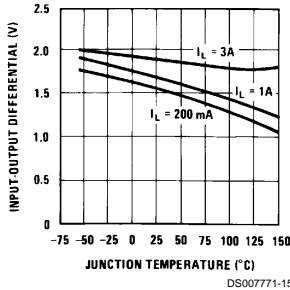

Line Transient Response

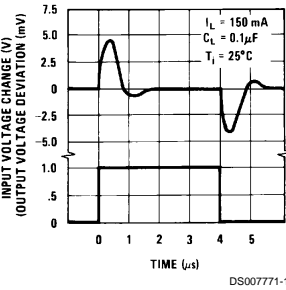

Output Voltage

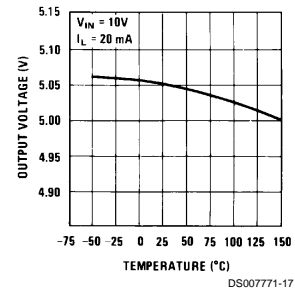

Typical Performance Characteristics (Continued)

Quiescent Current

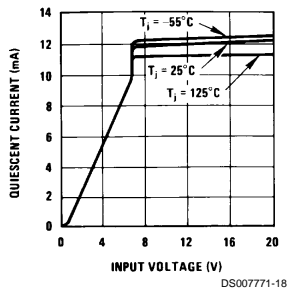

Load Transient Response

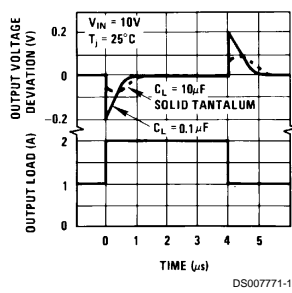

Output Noise Voltage

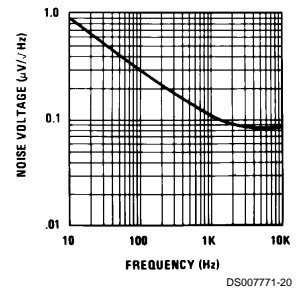

Typical Applications

10 Amp Regulator with Complete Overload Protection

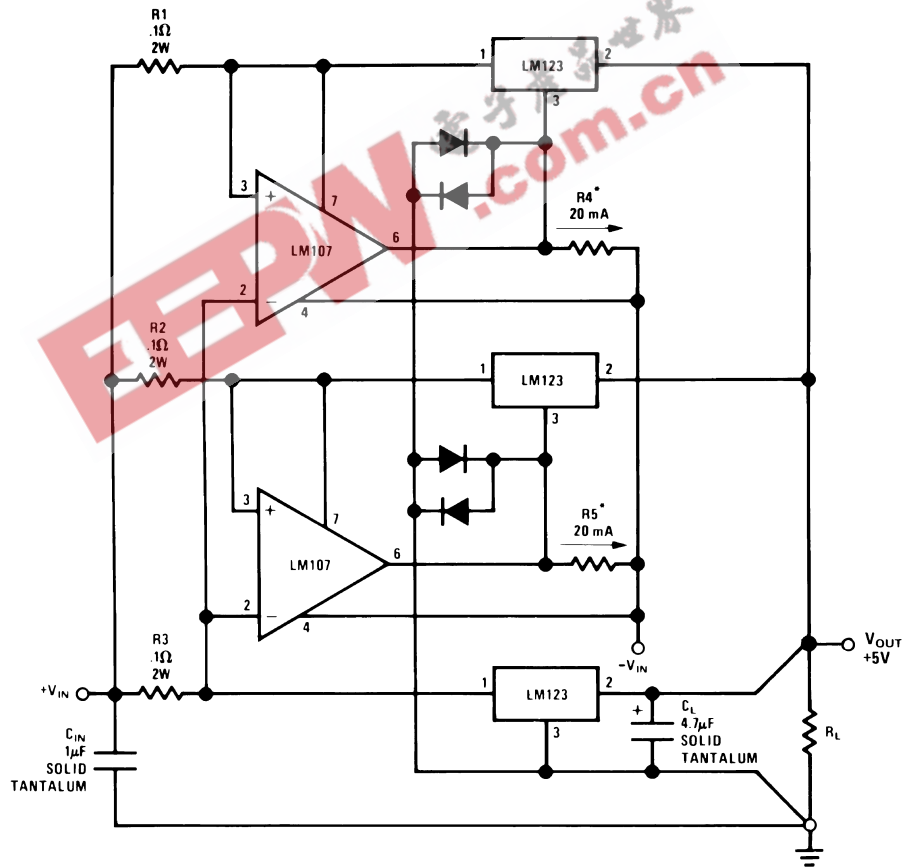

*Select for 20 mA Current from Unregulated Negative Supply

Typical Applications (Continued)

Adjustable Regulator 0V–10V @ 3A

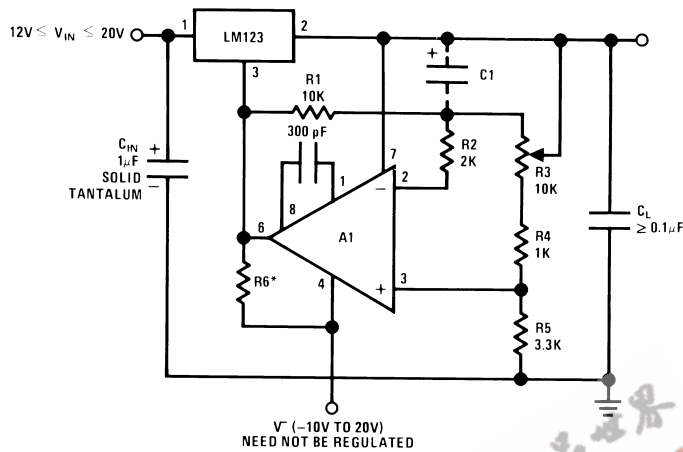

$$*R6 = \frac{V^-}{12 \text{ mA}}$$

A₁ — LM101A

C₁ — 2 μF Optional — Improves Ripple Rejection, Noise, and Transient Response

Trimming Output to 5V

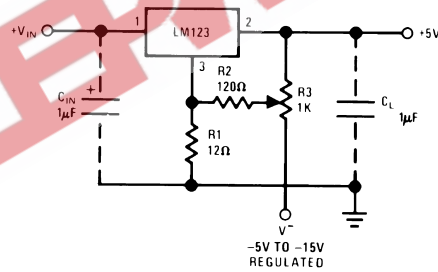

DS007771-8

Adjustable Output 5V–10V 0.1% Regulation

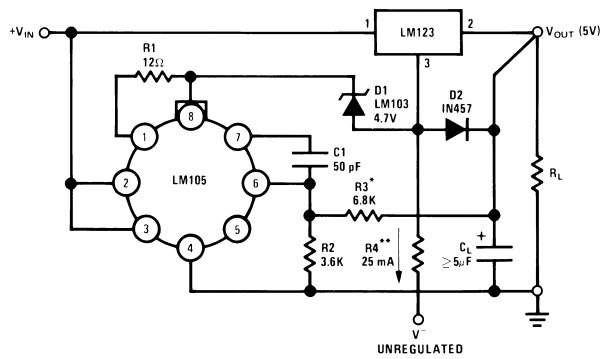

DS007771-4

*Select to Set Output Voltage

**Select to Draw 25 mA from V⁻

Schematic Diagram

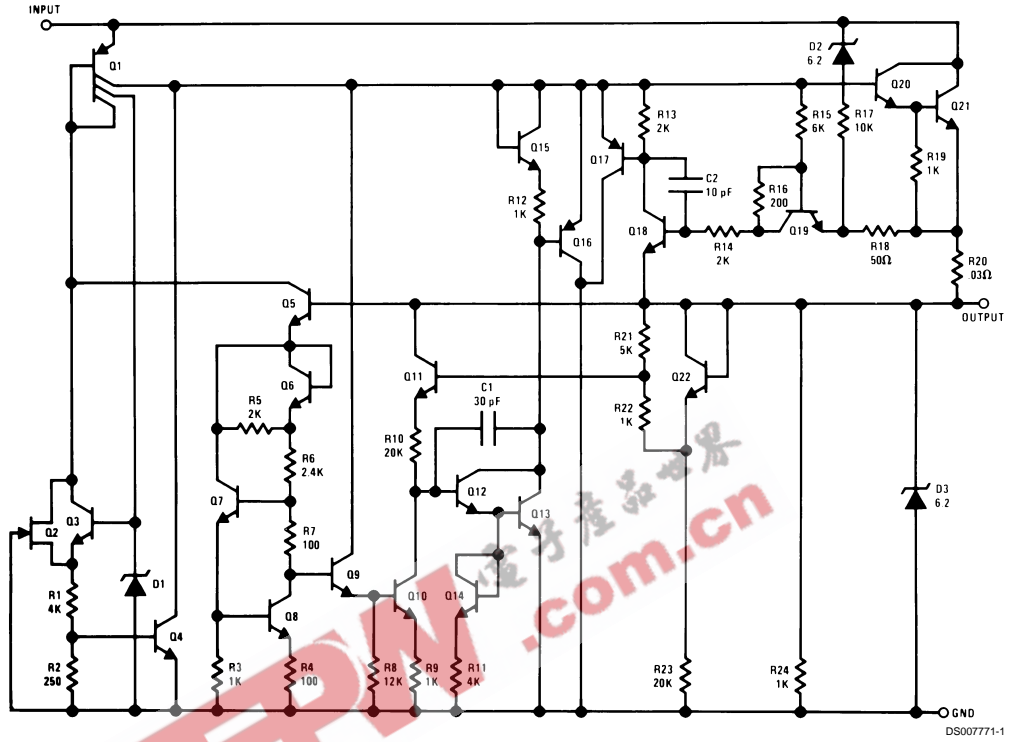

Physical Dimensions inches (millimeters) unless otherwise noted

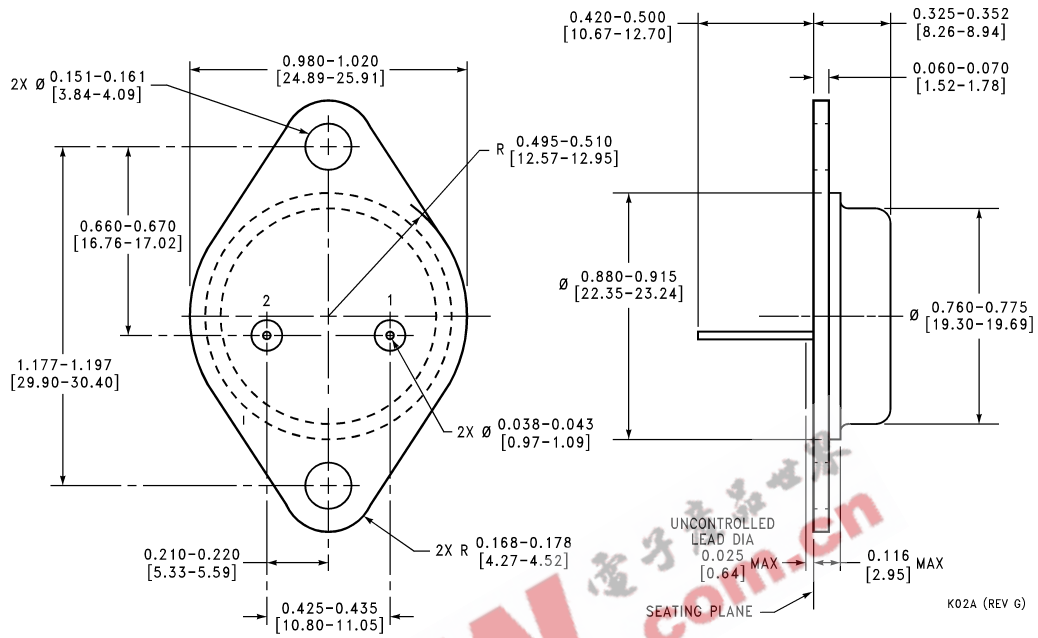

Metal Can Package (K)
Order Number LM123K STEEL, LM323AK STEEL or LM323K STEEL
NS Package Number K02A

Physical Dimensions inches (millimeters) unless otherwise noted (Continued)

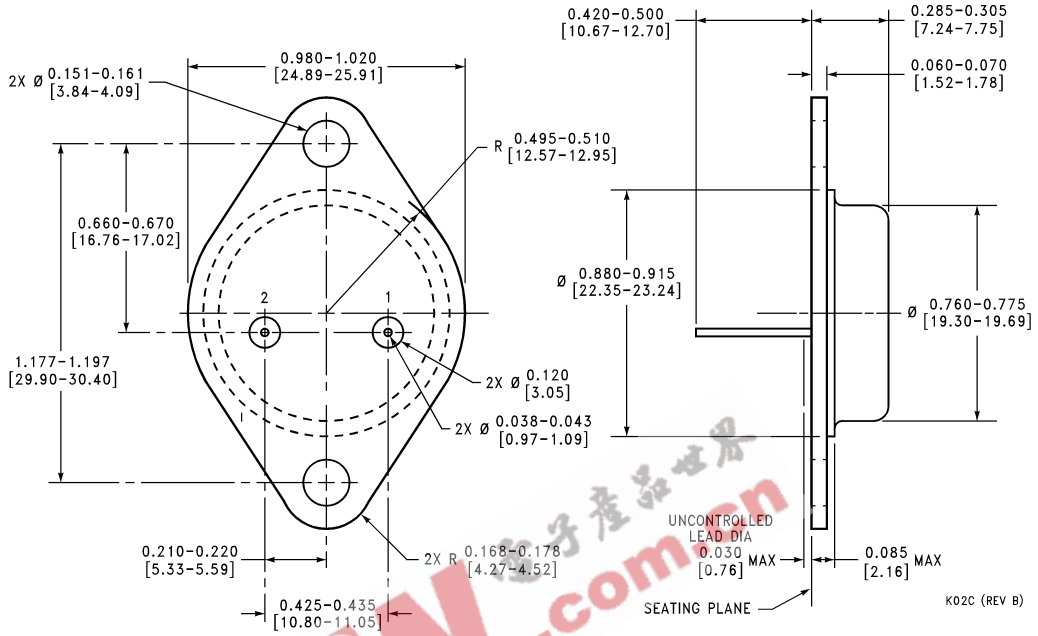

Metal Can Package (K)
Mil-Aero Product
Order Number LM123K/883
NS Package Number K02C

LIFE SUPPORT POLICY

NATIONAL'S PRODUCTS ARE NOT AUTHORIZED FOR USE AS CRITICAL COMPONENTS IN LIFE SUPPORT DEVICES OR SYSTEMS WITHOUT THE EXPRESS WRITTEN APPROVAL OF THE PRESIDENT AND GENERAL COUNSEL OF NATIONAL SEMICONDUCTOR CORPORATION. As used herein:

1. Life support devices or systems are devices or systems which, (a) are intended for surgical implant into the body, or (b) support or sustain life, and whose failure to perform when properly used in accordance with instructions for use provided in the labeling, can be reasonably expected to result in a significant injury to the user.
2. A critical component is any component of a life support device or system whose failure to perform can be reasonably expected to cause the failure of the life support device or system, or to affect its safety or effectiveness.



National Semiconductor Corporation
 Americas
 Tel: 1-800-272-9959
 Fax: 1-800-737-7018
 Email: support@nsc.com

www.national.com

National Semiconductor Europe
 Fax: +49 (0) 1 80-530 85 86
 Email: europe.support@nsc.com
 Deutsch Tel: +49 (0) 1 80-530 85 85
 English Tel: +49 (0) 1 80-532 78 32
 Français Tel: +49 (0) 1 80-532 93 58
 Italiano Tel: +49 (0) 1 80-534 16 80

National Semiconductor Asia Pacific Customer Response Group
 Tel: 65-2544466
 Fax: 65-2504466
 Email: sea.support@nsc.com

National Semiconductor Japan Ltd.
 Tel: 81-3-5639-7560
 Fax: 81-3-5639-7507