



# IC61LV256

## Document Title

32K x 8 Hight Speed SRAM with 3.3V

## Revision History

<u>Revision No</u>	<u>History</u>	<u>Draft Date</u>	<u>Remark</u>
0A	Initial Draft	April 19,2002	
0B	Add Pb-free parts	November 28,2003	



The attached datasheets are provided by ICSI. Integrated Circuit Solution Inc reserve the right to change the specifications and products. ICSI will answer to your questions about device. If you have any questions, please contact the ICSI offices.

## 32K x 8 HIGH SPEED CMOS STATIC RAM

### FEATURES

- High-speed access times:
  - 8, 10, 12, 15 ns
- Automatic power-down when chip is deselected
- CMOS low power operation
  - 345 mW (max.) operating
  - 7 mW (max.) CMOS standby
- TTL compatible interface levels
- Single 3.3V power supply
- Fully static operation: no clock or refresh required
- Three-state outputs

### DESCRIPTION

The *ICSI* IC61LV256 is a very high-speed, low power, 32,768-word by 8-bit static RAM. It is fabricated using *ICSI's* high-performance CMOS technology. This highly reliable process coupled with innovative circuit design techniques, yields access times as fast as 8 ns maximum.

When  $\overline{CE}$  is HIGH (deselected), the device assumes a standby mode at which the power dissipation is reduced to 600  $\mu$ W (typical) with CMOS input levels.

Easy memory expansion is provided by using an active LOW Chip Enable ( $\overline{CE}$ ). The active LOW Write Enable ( $\overline{WE}$ ) controls both writing and reading of the memory.

The IC61LV256 is available in the JEDEC standard 28-pin, 300mil SOJ and the 8\*13.4mm TSOP-1 package.

### FUNCTIONAL BLOCK DIAGRAM

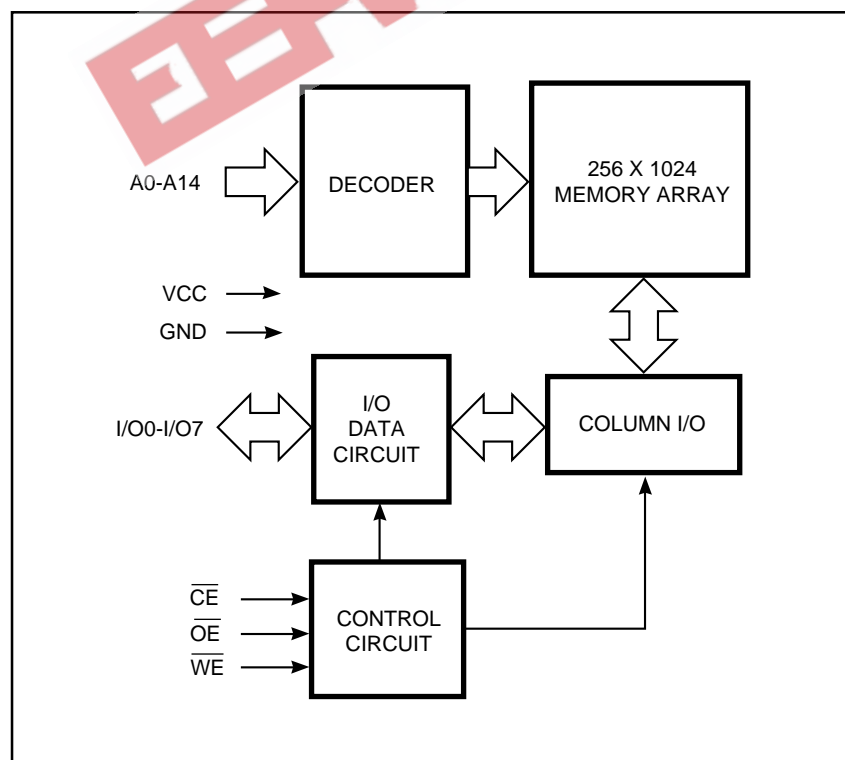

# IC61LV256

## PIN CONFIGURATION 28-Pin SOJ

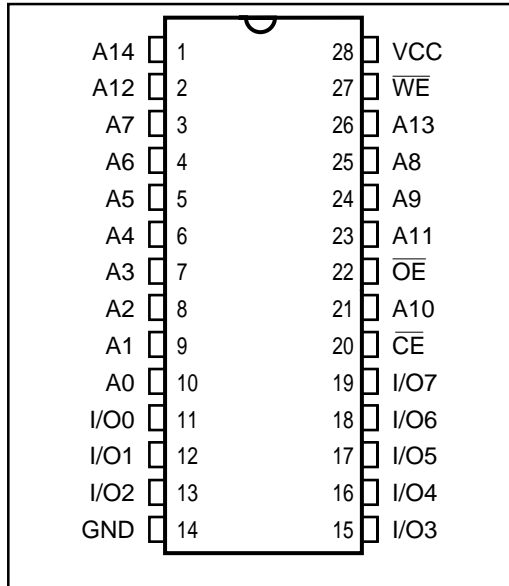

## PIN CONFIGURATION 8x13.4mm TSOP-1

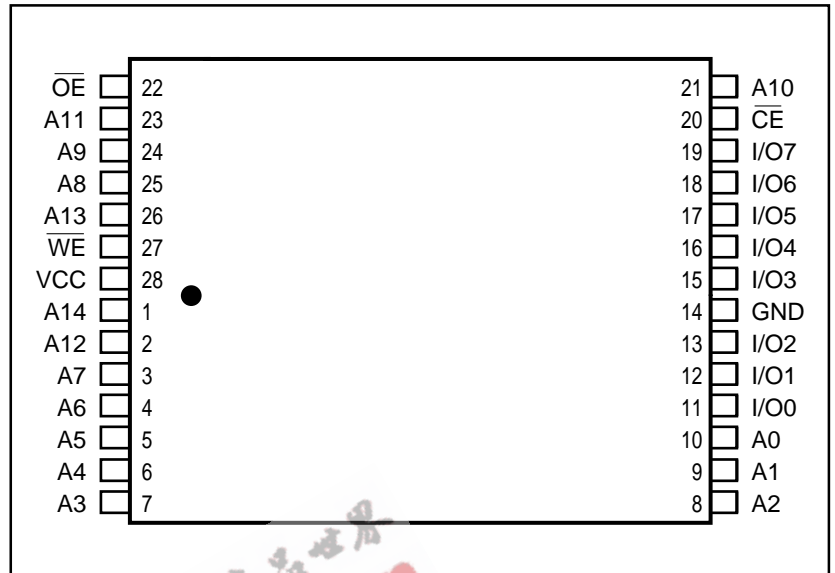

## PIN DESCRIPTIONS

A0-A14	Address Inputs
$\overline{CE}$	Chip Enable Input
$\overline{OE}$	Output Enable Input
$\overline{WE}$	Write Enable Input
I/O0-I/O7	Input/Output
Vcc	Power
GND	Ground

## TRUTH TABLE

Mode	$\overline{WE}$	$\overline{CE}$	$\overline{OE}$	I/O Operation	Vcc Current
Not Selected (Power-down)	X	H	X	High-Z	Isb1, Isb2
Output Disabled	H	L	H	High-Z	Icc
Read	H	L	L	Dout	Icc
Write	L	L	X	Din	Icc

## ABSOLUTE MAXIMUM RATINGS<sup>(1)</sup>

Symbol	Parameter	Value	Unit
Vcc	Power Supply Voltage Relative to GND	-0.5 to +4.6	V
VTERM	Terminal Voltage with Respect to GND	-0.5 to +4.6	V
TBIAS	Temperature Under Bias	Com. -10 to +85 Ind. -45 to +90	°C
TSTG	Storage Temperature	-65 to +150	°C
Pd	Power Dissipation	1	W
IOUT	DC Output Current	±20	mA

### Notes:

1. Stress greater than those listed under ABSOLUTE MAXIMUM RATINGS may cause permanent damage to the device. This is a stress rating only and functional operation of the device at these or any other conditions above those indicated in the operational sections of this specification is not implied. Exposure to absolute maximum rating conditions for extended periods may affect reliability.

**OPERATING RANGE**

Range	Ambient Temperature	Speed	V <sub>CC</sub>
Commercial	0°C to +70°C	8, 10, 12 15	3.3V, +10%, -5% 3.3V ± 10%
Industrial	-40°C to +85°C	All	3.3V + 10%, -5%

**DC ELECTRICAL CHARACTERISTICS** (Over Operating Range)

Symbol	Parameter	Test Conditions	Min.	Max.	Unit
V <sub>OH</sub>	Output HIGH Voltage	V <sub>CC</sub> = Min., I <sub>OH</sub> = -4.0 mA	2.4	—	V
V <sub>OL</sub>	Output LOW Voltage	V <sub>CC</sub> = Min., I <sub>OL</sub> = 8.0 mA	—	0.4	V
V <sub>IH</sub>	Input HIGH Voltage		2.2	V <sub>CC</sub> + 0.3	V
V <sub>IL</sub>	Input LOW Voltage <sup>(1)</sup>		-0.3	0.8	V
I <sub>LI</sub>	Input Leakage	GND ≤ V <sub>IN</sub> ≤ V <sub>CC</sub>	Com. -1 Ind. -5	1 5	μA
I <sub>LO</sub>	Output Leakage	GND ≤ V <sub>OUT</sub> ≤ V <sub>CC</sub> , Outputs Disabled	Com. -1 Ind. -5	1 5	μA

**Notes:**

- V<sub>IL</sub> (min.) = -0.3V (DC); V<sub>IL</sub> (min.) = -2.0V (pulse width ≤ 2.0 ns).  
V<sub>IH</sub> (max.) = V<sub>CC</sub> + 0.5V (DC); V<sub>IH</sub> (max.) = V<sub>CC</sub> + 2.0V (pulse width ≤ 2.0 ns).
- Not more than one output should be shorted at one time. Duration of the short circuit should not exceed 30 seconds.

**POWER SUPPLY CHARACTERISTICS<sup>(1)</sup>** (Over Operating Range)

Sym.	Parameter	Test Conditions		Rise/Fall Times				Unit
				-8 ns Min. Max.	-10 ns Min. Max.	-12 ns Min. Max.	-15 ns Min. Max.	
I <sub>CC</sub>	V <sub>CC</sub> Dynamic Operating Supply Current	V <sub>CC</sub> = Max., $\overline{CE} = V_{IL}$ I <sub>OUT</sub> = 0 mA, f = f <sub>MAX</sub>	Com. Ind.	— 120 — 130	— 110 — 120	— 100 — 110	— 90 — 100	mA
I <sub>SB1</sub>	TTL Standby Current (TTL Inputs)	V <sub>CC</sub> = Max., V <sub>IN</sub> = V <sub>IH</sub> or V <sub>IL</sub> $\overline{CE} \geq V_{IH}$ , f = 0	Com. Ind.	— 25 — 30	— 25 — 30	— 25 — 30	— 25 — 30	mA
I <sub>SB2</sub>	CMOS Standby Current (CMOS Inputs)	V <sub>CC</sub> = Max., $\overline{CE} \leq V_{CC} - 0.2V$ , V <sub>IN</sub> ≥ V <sub>CC</sub> - 0.2V, or V <sub>IN</sub> ≤ 0.2V, f = 0	Com. Ind.	— 2 — 5	— 2 — 5	— 2 — 5	— 2 — 5	mA

**Notes:**

- At f = f<sub>MAX</sub>, address and data inputs are cycling at the maximum frequency, f = 0 means no input lines change.

**CAPACITANCE<sup>(1,2)</sup>**

Symbol	Parameter	Conditions	Max.	Unit
C <sub>IN</sub>	Input Capacitance	V <sub>IN</sub> = 0V	6	pF
C <sub>OUT</sub>	Output Capacitance	V <sub>OUT</sub> = 0V	5	pF

**Notes:**

- Tested initially and after any design or process changes that may affect these parameters.
- Test conditions: T<sub>A</sub> = 25°C, f = 1 MHz, V<sub>CC</sub> = 3.3V.

# IC61LV256

## READ CYCLE SWITCHING CHARACTERISTICS<sup>(1)</sup> (Over Operating Range)

Symbol	Parameter	-8 ns		-10 ns		-12 ns		-15 ns		Unit
		Min.	Max.	Min.	Max.	Min.	Max.	Min.	Max.	
$t_{RC}$	Read Cycle Time	8	—	10	—	12	—	15	—	ns
$t_{AA}$	Address Access Time	—	8	—	10	—	12	—	15	ns
$t_{OHA}$	Output Hold Time	2	—	2	—	2	—	2	—	ns
$t_{ACE}$	$\overline{CE}$ Access Time	—	8	—	10	—	12	—	15	ns
$t_{DOE}$	$\overline{OE}$ Access Time	—	4	—	5	—	6	—	7	ns
$t_{LZOE}^{(2)}$	$\overline{OE}$ to Low-Z Output	0	—	0	—	0	—	0	—	ns
$t_{HZOE}^{(2)}$	$\overline{OE}$ to High-Z Output	—	4	—	5	—	5	—	6	ns
$t_{LZCE}^{(2)}$	$\overline{CE}$ to Low-Z Output	3	—	3	—	3	—	3	—	ns
$t_{HZCE}^{(2)}$	$\overline{CE}$ to High-Z Output	—	4	—	5	—	6	—	7	ns
$t_{PU}^{(3)}$	$\overline{CE}$ to Power-Up	0	—	0	—	0	—	0	—	ns
$t_{PD}^{(4)}$	$\overline{CE}$ to Power-Down	—	8	—	10	—	12	—	15	ns

### Notes:

1. Test conditions assume signal transition times of 3 ns or less, timing reference levels of 1.5V, input pulse levels of 0 to 3.0V and output loading specified in Figure 1.
2. Tested with the load in Figure 2. Transition is measured  $\pm 200$  mV from steady-state voltage. Not 100% tested.
3. Not 100% tested.

## AC TEST CONDITIONS

Parameter	Unit
Input Pulse Level	0V to 3.0V
Input Rise and Fall Times	3 ns
Input and Output Timing and Reference Levels	1.5V
Output Load	See Figures 1 and 2

## AC TEST LOADS

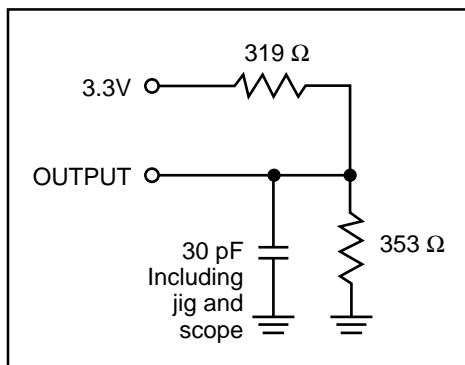

Figure 1.

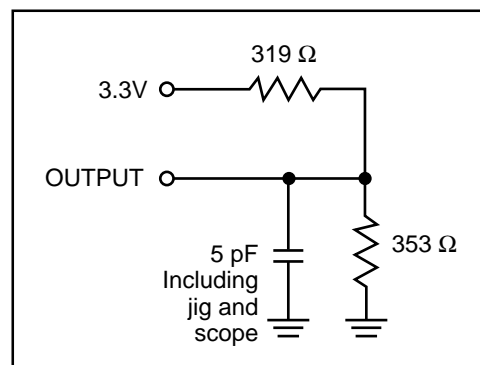
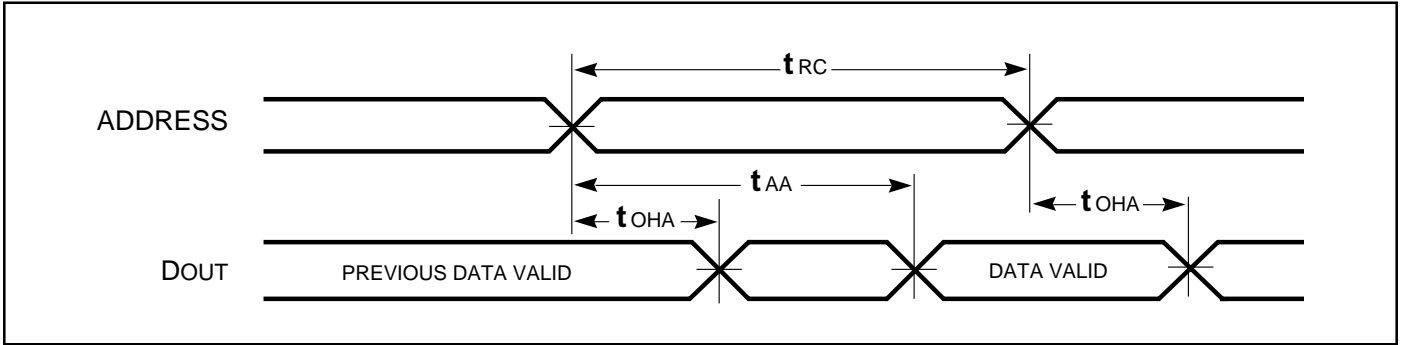

Figure 2.

AC WAVEFORMS

READ CYCLE NO. 1<sup>(1,2)</sup>



READ CYCLE NO. 2<sup>(1,3)</sup>

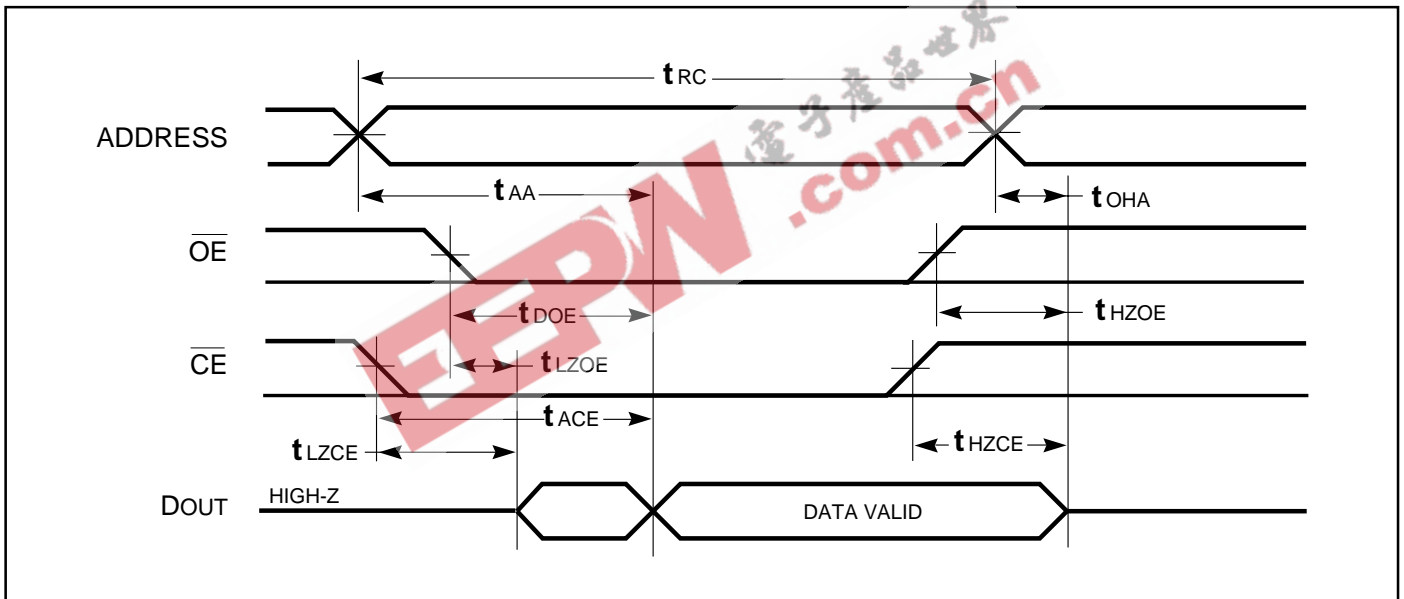

Notes:

1.  $\overline{WE}$  is HIGH for a Read Cycle.
2. The device is continuously selected.  $\overline{OE}, \overline{CE} = V_{IL}$ .
3. Address is valid prior to or coincident with  $\overline{CE}$  LOW transitions.

# IC61LV256

## WRITE CYCLE SWITCHING CHARACTERISTICS<sup>(1,2)</sup> (Over Operating Range)

Symbol	Parameter	-8 ns		-10 ns		-12 ns		-15 ns		Unit
		Min.	Max.	Min.	Max.	Min.	Max.	Min.	Max.	
t <sub>WC</sub>	Write Cycle Time	8	—	10	—	12	—	15	—	ns
t <sub>SCE</sub>	$\overline{CE}$ to Write End	7	—	8	—	8	—	10	—	ns
t <sub>AW</sub>	Address Setup Time to Write End	7	—	8	—	8	—	10	—	ns
t <sub>HA</sub>	Address Hold from Write End	0	—	0	—	0	—	0	—	ns
t <sub>SA</sub>	Address Setup Time	0	—	0	—	0	—	0	—	ns
t <sub>PWE<sup>(4)</sup></sub>	$\overline{WE}$ Pulse Width	7	—	10	—	12	—	15	—	ns
t <sub>SD</sub>	Data Setup to Write End	4.5	—	5	—	6	—	7	—	ns
t <sub>HD</sub>	Data Hold from Write End	0	—	0	—	0	—	0	—	ns
t <sub>HZWE<sup>(3)</sup></sub>	$\overline{WE}$ LOW to High-Z Output	—	3.5	—	4	—	6	—	7	ns
t <sub>LZWE<sup>(3)</sup></sub>	$\overline{WE}$ HIGH to Low-Z Output	0	—	0	—	0	—	0	—	ns

### Notes:

1. Test conditions assume signal transition times of 3 ns or less, timing reference levels of 1.5V, input pulse levels of 0 to 3.0V and output loading specified in Figure 1.
2. The internal write time is defined by the overlap of  $\overline{CE}$  LOW and  $\overline{WE}$  LOW. All signals must be in valid states to initiate a Write, but any one can go inactive to terminate the Write. The Data Input Setup and Hold timing are referenced to the rising or falling edge of the signal that terminates the Write.
3. Tested with the load in Figure 2. Transition is measured  $\pm 500$  mV from steady-state voltage. Not 100% tested.
4. Tested with  $\overline{OE}$  HIGH.

## AC WAVEFORMS

### WRITE CYCLE NO. 1 ( $\overline{CE}$ Controlled, $\overline{OE}$ is HIGH or LOW) <sup>(1)</sup>

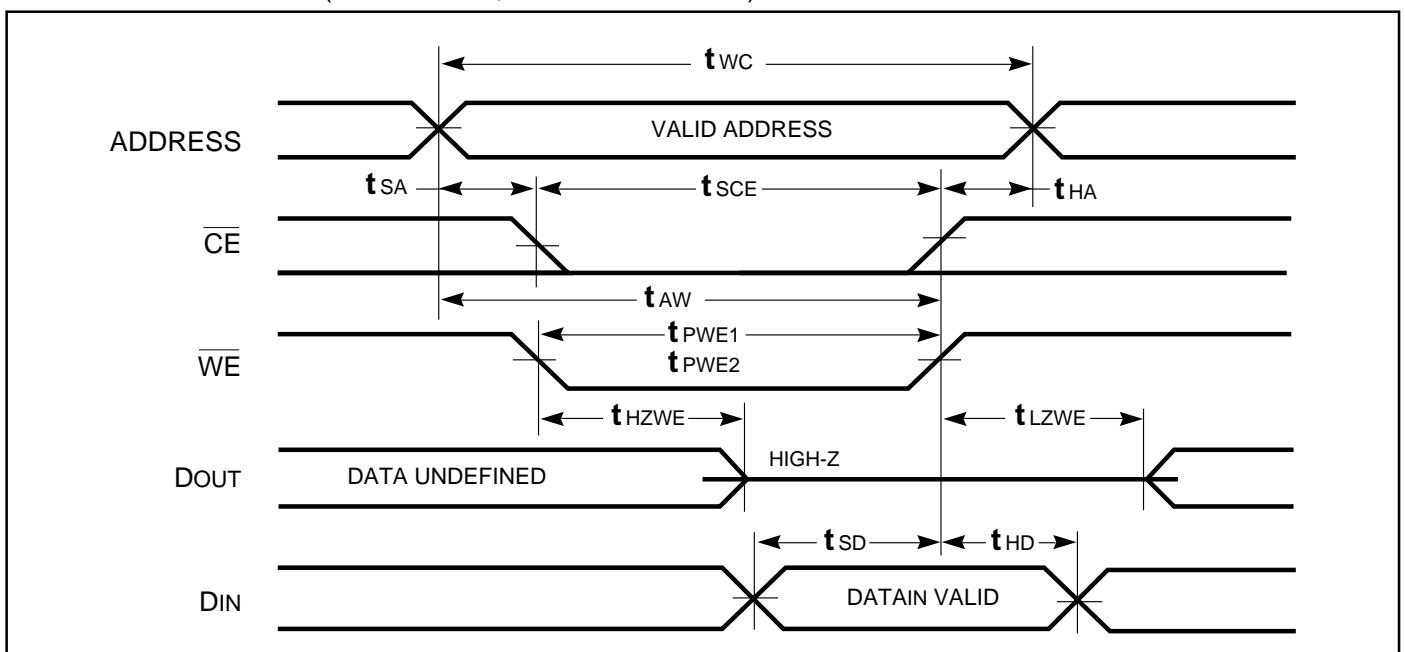

**WRITE CYCLE NO. 2** ( $\overline{WE}$  Controlled,  $\overline{OE}$  is HIGH During Write Cycle) <sup>(1,2)</sup>

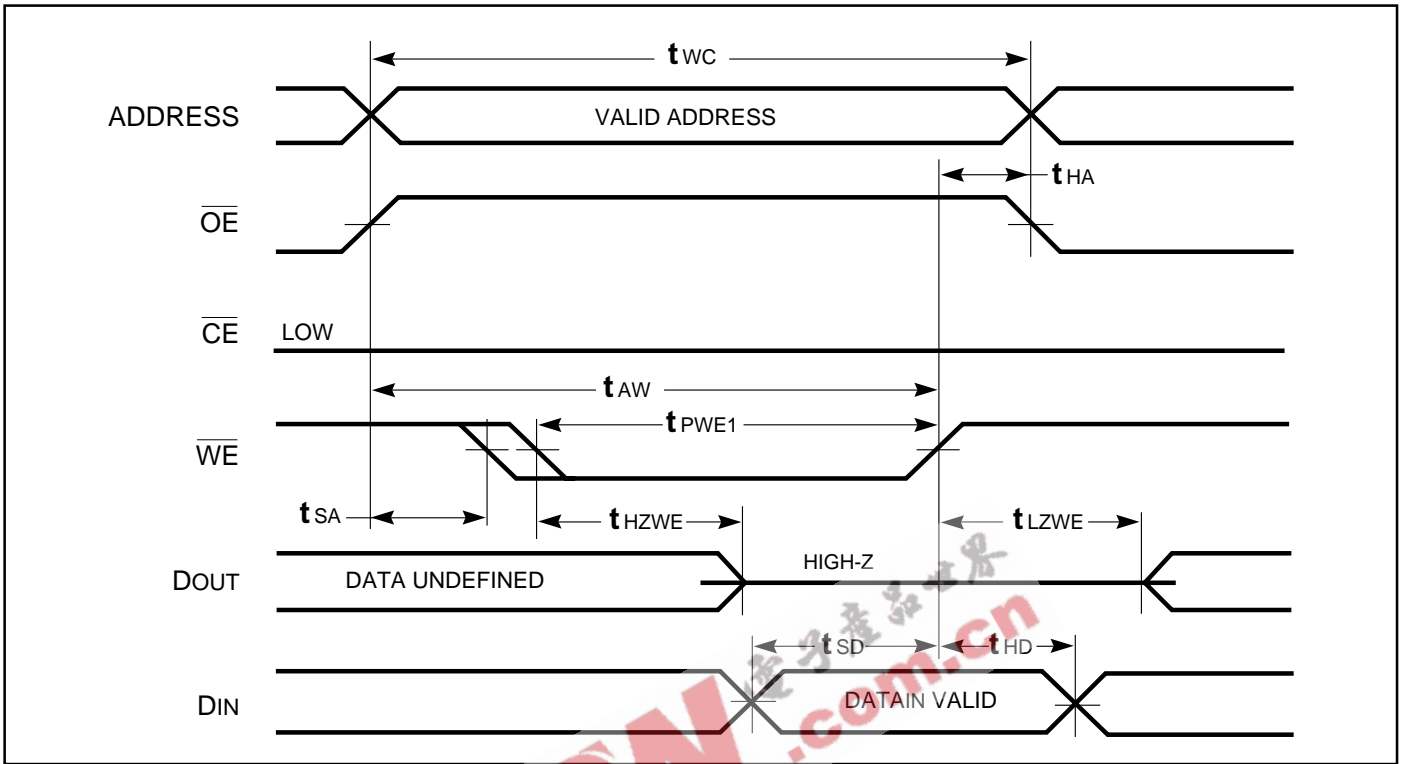

**WRITE CYCLE NO. 3** ( $\overline{WE}$  Controlled,  $\overline{OE}$  is LOW During Write Cycle) <sup>(1)</sup>

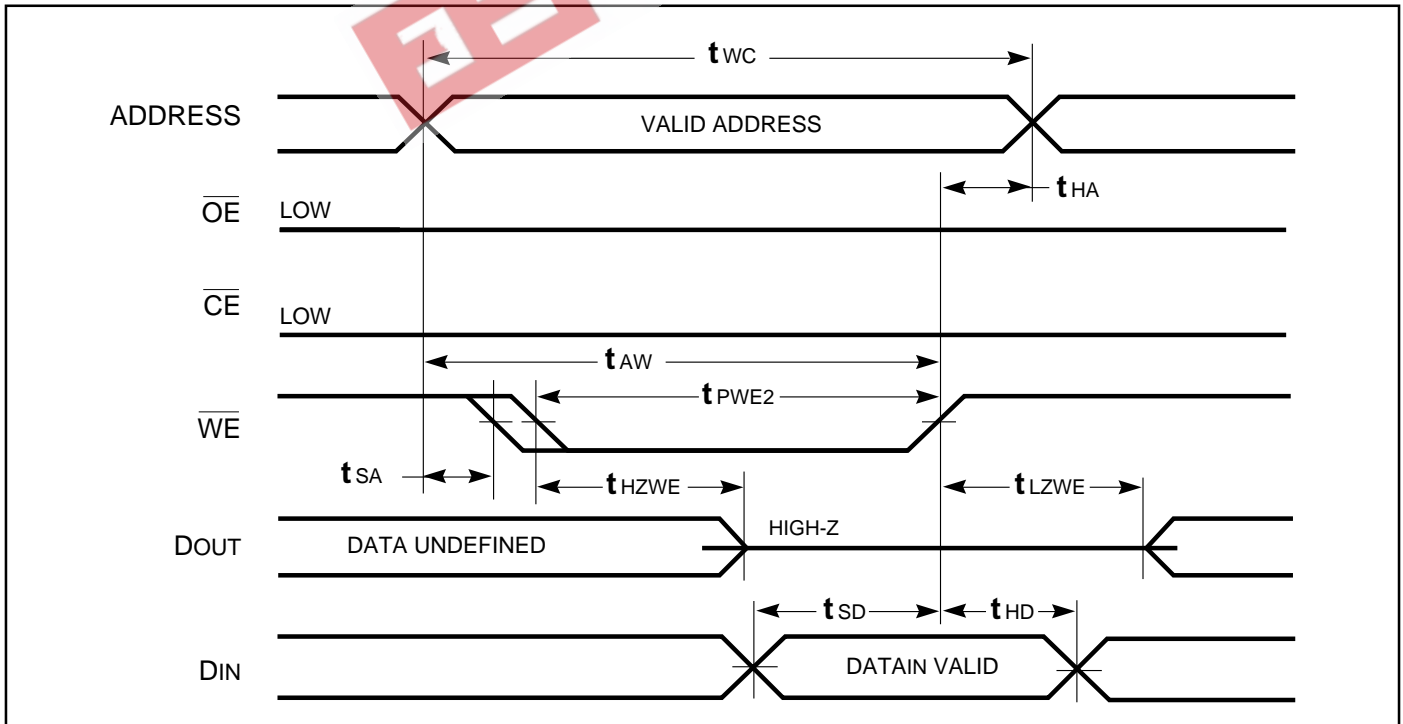

**Notes:**

1. The internal write time is defined by the overlap of  $\overline{CE}$  LOW and  $\overline{WE}$  LOW. All signals must be in valid states to initiate a Write, but any one can go inactive to terminate the Write. The Data Input Setup and Hold timing are referenced to the rising or falling edge of the signal that terminates the Write.
2. I/O will assume the High-Z state if  $\overline{OE} > V_{IH}$ .





# IC61LV256

## ORDERING INFORMATION

Commercial Range: 0°C to +70°C

Speed (ns)	Order Part No.	Package
8	IC61LV256-8T	8*13.4mm TSOP-1
	IC61LV256-8J	300mil SOJ
10	IC61LV256-10T	8*13.4mm TSOP-1
	IC61LV256-10J	300mil SOJ
12	IC61LV256-12T	8*13.4mm TSOP-1
	IC61LV256-12J	300mil SOJ
15	IC61LV256-15T	8*13.4mm TSOP-1
	IC61LV256-15J	300mil SOJ

## ORDERING INFORMATION

Industrial Range: -40°C to +85°C

Speed (ns)	Order Part No.	Package
8	IC61LV256-8TI	8*13.4mm TSOP-1
	IC61LV256-8JI	300mil SOJ
10	IC61LV256-10TI	8*13.4mm TSOP-1
	IC61LV256-10JI	300mil SOJ
12	IC61LV256-12TI	8*13.4mm TSOP-1
	IC61LV256-12JI	300mil SOJ
15	IC61LV256-15TI	8*13.4mm TSOP-1
	IC61LV256-15JI	300mil SOJ

## ORDERING INFORMATION (Pb-free)

Commercial Range: 0°C to +70°C

Speed (ns)	Order Part No.	Package
8	IC61LV256-8TG	8*13.4mm TSOP-1
	IC61LV256-8JG	300mil SOJ
10	IC61LV256-10TG	8*13.4mm TSOP-1
	IC61LV256-10JG	300mil SOJ
12	IC61LV256-12TG	8*13.4mm TSOP-1
	IC61LV256-12JG	300mil SOJ
15	IC61LV256-15TG	8*13.4mm TSOP-1
	IC61LV256-15JG	300mil SOJ

## ORDERING INFORMATION (Pb-free)

Industrial Range: -40°C to +85°C

Speed (ns)	Order Part No.	Package
8	IC61LV256-8TIG	8*13.4mm TSOP-1
	IC61LV256-8JIG	300mil SOJ
10	IC61LV256-10TIG	8*13.4mm TSOP-1
	IC61LV256-10JIG	300mil SOJ
12	IC61LV256-12TIG	8*13.4mm TSOP-1
	IC61LV256-12JIG	300mil SOJ
15	IC61LV256-15TIG	8*13.4mm TSOP-1
	IC61LV256-15JIG	300mil SOJ



**Integrated Circuit Solution Inc.**

HEADQUARTER:  
 NO.2, TECHNOLOGY RD. V, SCIENCE-BASED INDUSTRIAL PARK,  
 HSIN-CHU, TAIWAN, R.O.C.  
 TEL: 886-3-5780333  
 Fax: 886-3-5783000

BRANCH OFFICE:  
 7F, NO. 106, SEC. 1, HSIN-TAI 5<sup>TH</sup> ROAD,  
 HSICHIH TAIPEI COUNTY, TAIWAN, R.O.C.  
 TEL: 886-2-26962140  
 FAX: 886-2-26962252  
<http://www.icsi.com.tw>