

KA78XX/KA78XXA

3-Terminal 1A Positive Voltage Regulator

Features

- Output Current up to 1A
- Output Voltages of 5, 6, 8, 9, 10, 12, 15, 18, 24V
- Thermal Overload Protection
- Short Circuit Protection
- Output Transistor Safe Operating Area Protection

Description

The KA78XX/KA78XXA series of three-terminal positive regulator are available in the TO-220/D-PAK package and with several fixed output voltages, making them useful in a wide range of applications. Each type employs internal current limiting, thermal shut down and safe operating area protection, making it essentially indestructible. If adequate heat sinking is provided, they can deliver over 1A output current. Although designed primarily as fixed voltage regulators, these devices can be used with external components to obtain adjustable voltages and currents.



Internal Block Diagram

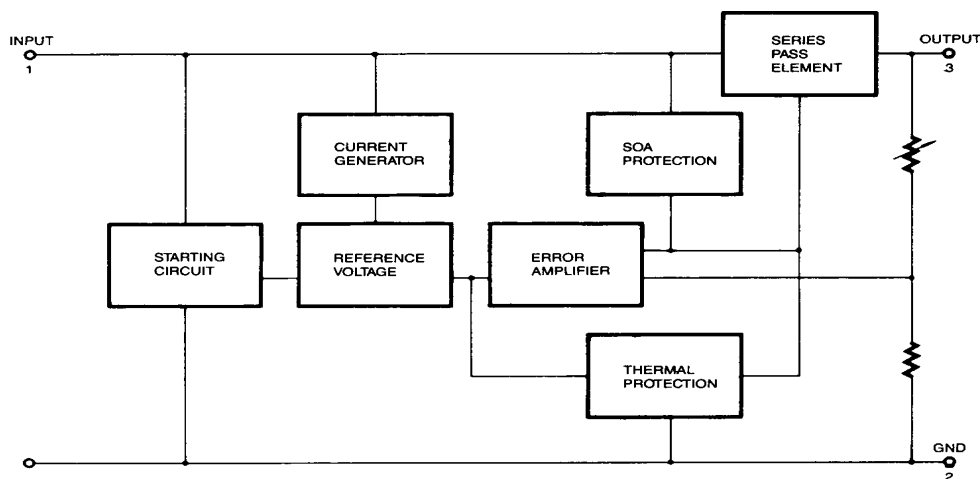

Absolute Maximum Ratings

Parameter	Symbol	Value	Unit
Input Voltage (for $V_O = 5V$ to $18V$) (for $V_O = 24V$)	V_I	35	V
	V_I	40	V
Thermal Resistance Junction-Cases (TO-220)	$R_{\theta JC}$	5	$^{\circ}C/W$
Thermal Resistance Junction-Air (TO-220)	$R_{\theta JA}$	65	$^{\circ}C/W$
Operating Temperature Range (KA78XX/A/R)	T_{OPR}	0 ~ +125	$^{\circ}C$
Storage Temperature Range	T_{STG}	-65 ~ +150	$^{\circ}C$

Electrical Characteristics (KA7805/KA7805R)

(Refer to test circuit , $0^{\circ}C < T_J < 125^{\circ}C$, $I_O = 500mA$, $V_I = 10V$, $C_I = 0.33\mu F$, $C_O = 0.1\mu F$, unless otherwise specified)

Parameter	Symbol	Conditions	KA7805			Unit	
			Min.	Typ.	Max.		
Output Voltage	V_O	$T_J = +25^{\circ}C$	4.8	5.0	5.2	V	
		$5.0mA \leq I_O \leq 1.0A$, $P_O \leq 15W$ $V_I = 7V$ to $20V$	4.75	5.0	5.25		
Line Regulation (Note1)	Regline	$T_J = +25^{\circ}C$	$V_O = 7V$ to $25V$	-	4.0	100	mV
			$V_I = 8V$ to $12V$	-	1.6	50	
Load Regulation (Note1)	Regload	$T_J = +25^{\circ}C$	$I_O = 5.0mA$ to $1.5A$	-	9	100	mV
			$I_O = 250mA$ to $750mA$	-	4	50	
Quiescent Current	I_Q	$T_J = +25^{\circ}C$	-	5.0	8.0	mA	
Quiescent Current Change	ΔI_Q	$I_O = 5mA$ to $1.0A$	-	0.03	0.5	mA	
		$V_I = 7V$ to $25V$	-	0.3	1.3		
Output Voltage Drift	$\Delta V_O / \Delta T$	$I_O = 5mA$	-	-0.8	-	mV/ $^{\circ}C$	
Output Noise Voltage	V_N	$f = 10Hz$ to $100KHz$, $T_A = +25^{\circ}C$	-	42	-	$\mu V/V_O$	
Ripple Rejection	RR	$f = 120Hz$ $V_O = 8V$ to $18V$	62	73	-	dB	
Dropout Voltage	V_{Drop}	$I_O = 1A$, $T_J = +25^{\circ}C$	-	2	-	V	
Output Resistance	r_O	$f = 1KHz$	-	15	-	m Ω	
Short Circuit Current	I_{SC}	$V_I = 35V$, $T_A = +25^{\circ}C$	-	230	-	mA	
Peak Current	I_{PK}	$T_J = +25^{\circ}C$	-	2.2	-	A	

Note:

1. Load and line regulation are specified at constant junction temperature. Changes in V_O due to heating effects must be taken into account separately. Pulse testing with low duty is used.

Electrical Characteristics (KA7806/KA7806R)

(Refer to test circuit , $0^{\circ}\text{C} < T_J < 125^{\circ}\text{C}$, $I_O = 500\text{mA}$, $V_I = 11\text{V}$, $C_I = 0.33\mu\text{F}$, $C_O = 0.1\mu\text{F}$, unless otherwise specified)

Parameter	Symbol	Conditions	KA7806			Unit	
			Min.	Typ.	Max.		
Output Voltage	V_O	$T_J = +25^{\circ}\text{C}$	5.75	6.0	6.25	V	
		$5.0\text{mA} \leq I_O \leq 1.0\text{A}$, $P_O \leq 15\text{W}$ $V_I = 8.0\text{V to } 21\text{V}$	5.7	6.0	6.3		
Line Regulation (Note1)	Regline	$T_J = +25^{\circ}\text{C}$	$V_I = 8\text{V to } 25\text{V}$	-	5	120	mV
			$V_I = 9\text{V to } 13\text{V}$	-	1.5	60	
Load Regulation (Note1)	Regload	$T_J = +25^{\circ}\text{C}$	$I_O = 5\text{mA to } 1.5\text{A}$	-	9	120	mV
			$I_O = 250\text{mA to } 750\text{mA}$	-	3	60	
Quiescent Current	I_Q	$T_J = +25^{\circ}\text{C}$	-	5.0	8.0	mA	
Quiescent Current Change	ΔI_Q	$I_O = 5\text{mA to } 1\text{A}$	-	-	0.5	mA	
		$V_I = 8\text{V to } 25\text{V}$	-	-	1.3		
Output Voltage Drift	$\Delta V_O / \Delta T$	$I_O = 5\text{mA}$	-	-0.8	-	mV/ $^{\circ}\text{C}$	
Output Noise Voltage	V_N	$f = 10\text{Hz to } 100\text{kHz}$, $T_A = +25^{\circ}\text{C}$	-	45	-	$\mu\text{V}/V_O$	
Ripple Rejection	RR	$f = 120\text{Hz}$ $V_I = 9\text{V to } 19\text{V}$	59	75	-	dB	
Dropout Voltage	V_{Drop}	$I_O = 1\text{A}$, $T_J = +25^{\circ}\text{C}$	-	2	-	V	
Output Resistance	r_O	$f = 1\text{kHz}$	-	19	-	$\text{m}\Omega$	
Short Circuit Current	I_{SC}	$V_I = 35\text{V}$, $T_A = +25^{\circ}\text{C}$	-	250	-	mA	
Peak Current	I_{PK}	$T_J = +25^{\circ}\text{C}$	-	2.2	-	A	

Note:

1. Load and line regulation are specified at constant junction temperature. Changes in V_O due to heating effects must be taken into account separately. Pulse testing with low duty is used.

Electrical Characteristics (KA7808/KA7808R)

(Refer to test circuit , $0^{\circ}\text{C} < T_J < 125^{\circ}\text{C}$, $I_O = 500\text{mA}$, $V_I = 14\text{V}$, $C_I = 0.33\mu\text{F}$, $C_O = 0.1\mu\text{F}$, unless otherwise specified)

Parameter	Symbol	Conditions	KA7808			Unit	
			Min.	Typ.	Max.		
Output Voltage	V_O	$T_J = +25^{\circ}\text{C}$	7.7	8.0	8.3	V	
		$5.0\text{mA} \leq I_O \leq 1.0\text{A}$, $P_O \leq 15\text{W}$ $V_I = 10.5\text{V to } 23\text{V}$	7.6	8.0	8.4		
Line Regulation (Note1)	Regline	$T_J = +25^{\circ}\text{C}$	$V_I = 10.5\text{V to } 25\text{V}$	-	5.0	160	mV
			$V_I = 11.5\text{V to } 17\text{V}$	-	2.0	80	
Load Regulation (Note1)	Regload	$T_J = +25^{\circ}\text{C}$	$I_O = 5.0\text{mA to } 1.5\text{A}$	-	10	160	mV
			$I_O = 250\text{mA to } 750\text{mA}$	-	5.0	80	
Quiescent Current	I_Q	$T_J = +25^{\circ}\text{C}$	-	5.0	8.0	mA	
Quiescent Current Change	ΔI_Q	$I_O = 5\text{mA to } 1.0\text{A}$	-	0.05	0.5	mA	
		$V_I = 10.5\text{V to } 25\text{V}$	-	0.5	1.0		
Output Voltage Drift	$\Delta V_O / \Delta T$	$I_O = 5\text{mA}$	-	-0.8	-	mV/ $^{\circ}\text{C}$	
Output Noise Voltage	V_N	$f = 10\text{Hz to } 100\text{kHz}$, $T_A = +25^{\circ}\text{C}$	-	52	-	$\mu\text{V}/V_O$	
Ripple Rejection	RR	$f = 120\text{Hz}$, $V_I = 11.5\text{V to } 21.5\text{V}$	56	73	-	dB	
Dropout Voltage	V_{Drop}	$I_O = 1\text{A}$, $T_J = +25^{\circ}\text{C}$	-	2	-	V	
Output Resistance	r_O	$f = 1\text{kHz}$	-	17	-	$\text{m}\Omega$	
Short Circuit Current	I_{SC}	$V_I = 35\text{V}$, $T_A = +25^{\circ}\text{C}$	-	230	-	mA	
Peak Current	I_{PK}	$T_J = +25^{\circ}\text{C}$	-	2.2	-	A	

Note:

1. Load and line regulation are specified at constant junction temperature. Changes in V_O due to heating effects must be taken into account separately. Pulse testing with low duty is used.

Electrical Characteristics (KA7809/KA7809R)

(Refer to test circuit , $0^{\circ}\text{C} < T_J < 125^{\circ}\text{C}$, $I_O = 500\text{mA}$, $V_I = 15\text{V}$, $C_I = 0.33\mu\text{F}$, $C_O = 0.1\mu\text{F}$, unless otherwise specified)

Parameter	Symbol	Conditions	KA7809			Unit	
			Min.	Typ.	Max.		
Output Voltage	V_O	$T_J = +25^{\circ}\text{C}$	8.65	9	9.35	V	
		$5.0\text{mA} \leq I_O \leq 1.0\text{A}$, $P_O \leq 15\text{W}$ $V_I = 11.5\text{V to } 24\text{V}$	8.6	9	9.4		
Line Regulation (Note1)	Regline	$T_J = +25^{\circ}\text{C}$	$V_I = 11.5\text{V to } 25\text{V}$	-	6	180	mV
			$V_I = 12\text{V to } 17\text{V}$	-	2	90	
Load Regulation (Note1)	Regload	$T_J = +25^{\circ}\text{C}$	$I_O = 5\text{mA to } 1.5\text{A}$	-	12	180	mV
			$I_O = 250\text{mA to } 750\text{mA}$	-	4	90	
Quiescent Current	I_Q	$T_J = +25^{\circ}\text{C}$	-	5.0	8.0	mA	
Quiescent Current Change	ΔI_Q	$I_O = 5\text{mA to } 1.0\text{A}$	-	-	0.5	mA	
		$V_I = 11.5\text{V to } 26\text{V}$	-	-	1.3		
Output Voltage Drift	$\Delta V_O / \Delta T$	$I_O = 5\text{mA}$	-	-1	-	mV/ $^{\circ}\text{C}$	
Output Noise Voltage	V_N	$f = 10\text{Hz to } 100\text{KHz}$, $T_A = +25^{\circ}\text{C}$	-	58	-	$\mu\text{V}/V_O$	
Ripple Rejection	RR	$f = 120\text{Hz}$ $V_I = 13\text{V to } 23\text{V}$	56	71	-	dB	
Dropout Voltage	V_{Drop}	$I_O = 1\text{A}$, $T_J = +25^{\circ}\text{C}$	-	2	-	V	
Output Resistance	r_O	$f = 1\text{KHz}$	-	17	-	$\text{m}\Omega$	
Short Circuit Current	ISC	$V_I = 35\text{V}$, $T_A = +25^{\circ}\text{C}$	-	250	-	mA	
Peak Current	I_{PK}	$T_J = +25^{\circ}\text{C}$	-	2.2	-	A	

Note:

1. Load and line regulation are specified at constant junction temperature. Changes in V_O due to heating effects must be taken into account separately. Pulse testing with low duty is used.

Electrical Characteristics (KA7810)

(Refer to test circuit , $0^{\circ}\text{C} < T_J < 125^{\circ}\text{C}$, $I_O = 500\text{mA}$, $V_I = 16\text{V}$, $C_I = 0.33\mu\text{F}$, $C_O = 0.1\mu\text{F}$, unless otherwise specified)

Parameter	Symbol	Conditions	KA7810			Unit	
			Min.	Typ.	Max.		
Output Voltage	V_O	$T_J = +25^{\circ}\text{C}$	9.6	10	10.4	V	
		$5.0\text{mA} \leq I_O \leq 1.0\text{A}$, $P_O \leq 15\text{W}$ $V_I = 12.5\text{V to } 25\text{V}$	9.5	10	10.5		
Line Regulation (Note1)	Regline	$T_J = +25^{\circ}\text{C}$	$V_I = 12.5\text{V to } 25\text{V}$	-	10	200	mV
			$V_I = 13\text{V to } 25\text{V}$	-	3	100	
Load Regulation (Note1)	Regload	$T_J = +25^{\circ}\text{C}$	$I_O = 5\text{mA to } 1.5\text{A}$	-	12	200	mV
			$I_O = 250\text{mA to } 750\text{mA}$	-	4	400	
Quiescent Current	I_Q	$T_J = +25^{\circ}\text{C}$	-	5.1	8.0	mA	
Quiescent Current Change	ΔI_Q	$I_O = 5\text{mA to } 1.0\text{A}$	-	-	0.5	mA	
		$V_I = 12.5\text{V to } 29\text{V}$	-	-	1.0		
Output Voltage Drift	$\Delta V_O / \Delta T$	$I_O = 5\text{mA}$	-	-1	-	mV/ $^{\circ}\text{C}$	
Output Noise Voltage	V_N	$f = 10\text{Hz to } 100\text{KHz}$, $T_A = +25^{\circ}\text{C}$	-	58	-	$\mu\text{V}/V_O$	
Ripple Rejection	RR	$f = 120\text{Hz}$ $V_I = 13\text{V to } 23\text{V}$	56	71	-	dB	
Dropout Voltage	V_{Drop}	$I_O = 1\text{A}$, $T_J = +25^{\circ}\text{C}$	-	2	-	V	
Output Resistance	r_O	$f = 1\text{KHz}$	-	17	-	$\text{m}\Omega$	
Short Circuit Current	ISC	$V_I = 35\text{V}$, $T_A = +25^{\circ}\text{C}$	-	250	-	mA	
Peak Current	I_{PK}	$T_J = +25^{\circ}\text{C}$	-	2.2	-	A	

Note:

1. Load and line regulation are specified at constant junction temperature. Changes in V_O due to heating effects must be taken into account separately. Pulse testing with low duty is used.

Electrical Characteristics (KA7812/KA7812R)

(Refer to test circuit , $0^{\circ}\text{C} < T_J < 125^{\circ}\text{C}$, $I_O = 500\text{mA}$, $V_I = 19\text{V}$, $C_I = 0.33\mu\text{F}$, $C_O = 0.1\mu\text{F}$, unless otherwise specified)

Parameter	Symbol	Conditions	KA7812/KA7812R			Unit	
			Min.	Typ.	Max.		
Output Voltage	V_O	$T_J = +25^{\circ}\text{C}$	11.5	12	12.5	V	
		$5.0\text{mA} \leq I_O \leq 1.0\text{A}$, $P_O \leq 15\text{W}$ $V_I = 14.5\text{V to } 27\text{V}$	11.4	12	12.6		
Line Regulation (Note1)	Regline	$T_J = +25^{\circ}\text{C}$	$V_I = 14.5\text{V to } 30\text{V}$	-	10	240	mV
			$V_I = 16\text{V to } 22\text{V}$	-	3.0	120	
Load Regulation (Note1)	Regload	$T_J = +25^{\circ}\text{C}$	$I_O = 5\text{mA to } 1.5\text{A}$	-	11	240	mV
			$I_O = 250\text{mA to } 750\text{mA}$	-	5.0	120	
Quiescent Current	I_Q	$T_J = +25^{\circ}\text{C}$	-	5.1	8.0	mA	
Quiescent Current Change	ΔI_Q	$I_O = 5\text{mA to } 1.0\text{A}$	-	0.1	0.5	mA	
		$V_I = 14.5\text{V to } 30\text{V}$	-	0.5	1.0		
Output Voltage Drift	$\Delta V_O / \Delta T$	$I_O = 5\text{mA}$	-	-1	-	mV/ $^{\circ}\text{C}$	
Output Noise Voltage	V_N	$f = 10\text{Hz to } 100\text{KHz}$, $T_A = +25^{\circ}\text{C}$	-	76	-	$\mu\text{V}/V_O$	
Ripple Rejection	RR	$f = 120\text{Hz}$ $V_I = 15\text{V to } 25\text{V}$	55	71	-	dB	
Dropout Voltage	V_{Drop}	$I_O = 1\text{A}$, $T_J = +25^{\circ}\text{C}$	-	2	-	V	
Output Resistance	r_O	$f = 1\text{KHz}$	-	18	-	$\text{m}\Omega$	
Short Circuit Current	ISC	$V_I = 35\text{V}$, $T_A = +25^{\circ}\text{C}$	-	230	-	mA	
Peak Current	I_{PK}	$T_J = +25^{\circ}\text{C}$	-	2.2	-	A	

Note:

1. Load and line regulation are specified at constant junction temperature. Changes in V_O due to heating effects must be taken into account separately. Pulse testing with low duty is used.

Electrical Characteristics (KA7815)

(Refer to test circuit , $0^{\circ}\text{C} < T_J < 125^{\circ}\text{C}$, $I_O = 500\text{mA}$, $V_I = 23\text{V}$, $C_I = 0.33\mu\text{F}$, $C_O = 0.1\mu\text{F}$, unless otherwise specified)

Parameter	Symbol	Conditions	KA7815			Unit	
			Min.	Typ.	Max.		
Output Voltage	V_O	$T_J = +25^{\circ}\text{C}$	14.4	15	15.6	V	
		$5.0\text{mA} \leq I_O \leq 1.0\text{A}$, $P_O \leq 15\text{W}$ $V_I = 17.5\text{V to } 30\text{V}$	14.25	15	15.75		
Line Regulation (Note1)	Regline	$T_J = +25^{\circ}\text{C}$	$V_I = 17.5\text{V to } 30\text{V}$	-	11	300	mV
			$V_I = 20\text{V to } 26\text{V}$	-	3	150	
Load Regulation (Note1)	Regload	$T_J = +25^{\circ}\text{C}$	$I_O = 5\text{mA to } 1.5\text{A}$	-	12	300	mV
			$I_O = 250\text{mA to } 750\text{mA}$	-	4	150	
Quiescent Current	I_Q	$T_J = +25^{\circ}\text{C}$	-	5.2	8.0	mA	
Quiescent Current Change	ΔI_Q	$I_O = 5\text{mA to } 1.0\text{A}$	-	-	0.5	mA	
		$V_I = 17.5\text{V to } 30\text{V}$	-	-	1.0		
Output Voltage Drift	$\Delta V_O / \Delta T$	$I_O = 5\text{mA}$	-	-1	-	mV/ $^{\circ}\text{C}$	
Output Noise Voltage	V_N	$f = 10\text{Hz to } 100\text{kHz}$, $T_A = +25^{\circ}\text{C}$	-	90	-	$\mu\text{V}/V_O$	
Ripple Rejection	RR	$f = 120\text{Hz}$ $V_I = 18.5\text{V to } 28.5\text{V}$	54	70	-	dB	
Dropout Voltage	V_{Drop}	$I_O = 1\text{A}$, $T_J = +25^{\circ}\text{C}$	-	2	-	V	
Output Resistance	r_O	$f = 1\text{kHz}$	-	19	-	$\text{m}\Omega$	
Short Circuit Current	ISC	$V_I = 35\text{V}$, $T_A = +25^{\circ}\text{C}$	-	250	-	mA	
Peak Current	I_{PK}	$T_J = +25^{\circ}\text{C}$	-	2.2	-	A	

Note:

1. Load and line regulation are specified at constant junction temperature. Changes in V_O due to heating effects must be taken into account separately. Pulse testing with low duty is used.

Electrical Characteristics (KA7818)

(Refer to test circuit , $0^{\circ}\text{C} < T_J < 125^{\circ}\text{C}$, $I_O = 500\text{mA}$, $V_I = 27\text{V}$, $C_I = 0.33\mu\text{F}$, $C_O = 0.1\mu\text{F}$, unless otherwise specified)

Parameter	Symbol	Conditions	KA7818			Unit	
			Min.	Typ.	Max.		
Output Voltage	V_O	$T_J = +25^{\circ}\text{C}$	17.3	18	18.7	V	
		$5.0\text{mA} \leq I_O \leq 1.0\text{A}$, $P_O \leq 15\text{W}$ $V_I = 21\text{V to } 33\text{V}$	17.1	18	18.9		
Line Regulation (Note1)	Regline	$T_J = +25^{\circ}\text{C}$	$V_I = 21\text{V to } 33\text{V}$	-	15	360	mV
			$V_I = 24\text{V to } 30\text{V}$	-	5	180	
Load Regulation (Note1)	Regload	$T_J = +25^{\circ}\text{C}$	$I_O = 5\text{mA to } 1.5\text{A}$	-	15	360	mV
			$I_O = 250\text{mA to } 750\text{mA}$	-	5.0	180	
Quiescent Current	I_Q	$T_J = +25^{\circ}\text{C}$	-	5.2	8.0	mA	
Quiescent Current Change	ΔI_Q	$I_O = 5\text{mA to } 1.0\text{A}$	-	-	0.5	mA	
		$V_I = 21\text{V to } 33\text{V}$	-	-	1		
Output Voltage Drift	$\Delta V_O / \Delta T$	$I_O = 5\text{mA}$	-	-1	-	mV/ $^{\circ}\text{C}$	
Output Noise Voltage	V_N	$f = 10\text{Hz to } 100\text{kHz}$, $T_A = +25^{\circ}\text{C}$	-	110	-	$\mu\text{V}/V_O$	
Ripple Rejection	RR	$f = 120\text{Hz}$ $V_I = 22\text{V to } 32\text{V}$	53	69	-	dB	
Dropout Voltage	V_{Drop}	$I_O = 1\text{A}$, $T_J = +25^{\circ}\text{C}$	-	2	-	V	
Output Resistance	r_O	$f = 1\text{kHz}$	-	22	-	$\text{m}\Omega$	
Short Circuit Current	ISC	$V_I = 35\text{V}$, $T_A = +25^{\circ}\text{C}$	-	250	-	mA	
Peak Current	I_{PK}	$T_J = +25^{\circ}\text{C}$	-	2.2	-	A	

Note:

1. Load and line regulation are specified at constant junction temperature. Changes in V_O due to heating effects must be taken into account separately. Pulse testing with low duty is used.

Electrical Characteristics (KA7824)

(Refer to test circuit , $0^{\circ}\text{C} < T_J < 125^{\circ}\text{C}$, $I_O = 500\text{mA}$, $V_I = 33\text{V}$, $C_I = 0.33\mu\text{F}$, $C_O = 0.1\mu\text{F}$, unless otherwise specified)

Parameter	Symbol	Conditions	KA7824			Unit	
			Min.	Typ.	Max.		
Output Voltage	V _O	T _J = +25 °C	23	24	25	V	
		5.0mA ≤ I _O ≤ 1.0A, P _O ≤ 15W V _I = 27V to 38V	22.8	24	25.25		
Line Regulation (Note1)	Regline	T _J = +25 °C	V _I = 27V to 38V	-	17	480	mV
			V _I = 30V to 36V	-	6	240	
Load Regulation (Note1)	Regload	T _J = +25 °C	I _O = 5mA to 1.5A	-	15	480	mV
			I _O = 250mA to 750mA	-	5.0	240	
Quiescent Current	I _Q	T _J = +25 °C	-	5.2	8.0	mA	
Quiescent Current Change	ΔI _Q	I _O = 5mA to 1.0A	-	0.1	0.5	mA	
		V _I = 27V to 38V	-	0.5	1		
Output Voltage Drift	ΔV _O /ΔT	I _O = 5mA	-	-1.5	-	mV/°C	
Output Noise Voltage	V _N	f = 10Hz to 100KHz, T _A = +25 °C	-	60	-	μV/V _O	
Ripple Rejection	RR	f = 120Hz V _I = 28V to 38V	50	67	-	dB	
Dropout Voltage	V _{Drop}	I _O = 1A, T _J = +25 °C	-	2	-	V	
Output Resistance	r _O	f = 1KHz	-	28	-	mΩ	
Short Circuit Current	I _{SC}	V _I = 35V, T _A = +25 °C	-	230	-	mA	
Peak Current	I _{PK}	T _J = +25 °C	-	2.2	-	A	

Note:

1. Load and line regulation are specified at constant junction temperature. Changes in V_O due to heating effects must be taken into account separately. Pulse testing with low duty is used.

Electrical Characteristics (KA7805A)

(Refer to the test circuits. $0^{\circ}\text{C} < T_J < +125^{\circ}\text{C}$, $I_O = 1\text{A}$, $V_I = 10\text{V}$, $C_I = 0.33\mu\text{F}$, $C_O = 0.1\mu\text{F}$, unless otherwise specified)

Parameter	Symbol	Conditions	Min.	Typ.	Max.	Unit	
Output Voltage	V_O	$T_J = +25^{\circ}\text{C}$	4.9	5	5.1	V	
		$I_O = 5\text{mA to } 1\text{A}$, $P_O \leq 15\text{W}$ $V_I = 7.5\text{V to } 20\text{V}$	4.8	5	5.2		
Line Regulation (Note1)	Regline	$V_I = 7.5\text{V to } 25\text{V}$ $I_O = 500\text{mA}$	-	5	50	mV	
		$V_I = 8\text{V to } 12\text{V}$	-	3	50		
		$T_J = +25^{\circ}\text{C}$	$V_I = 7.3\text{V to } 20\text{V}$	-	5		50
			$V_I = 8\text{V to } 12\text{V}$	-	1.5		25
Load Regulation (Note1)	Regload	$T_J = +25^{\circ}\text{C}$ $I_O = 5\text{mA to } 1.5\text{A}$	-	9	100	mV	
		$I_O = 5\text{mA to } 1\text{A}$	-	9	100		
		$I_O = 250\text{mA to } 750\text{mA}$	-	4	50		
Quiescent Current	I_Q	$T_J = +25^{\circ}\text{C}$	-	5.0	6.0	mA	
Quiescent Current Change	ΔI_Q	$I_O = 5\text{mA to } 1\text{A}$	-	-	0.5	mA	
		$V_I = 8\text{V to } 25\text{V}$, $I_O = 500\text{mA}$	-	-	0.8		
		$V_I = 7.5\text{V to } 20\text{V}$, $T_J = +25^{\circ}\text{C}$	-	-	0.8		
Output Voltage Drift	$\Delta V/\Delta T$	$I_O = 5\text{mA}$	-	-0.8	-	mV/ $^{\circ}\text{C}$	
Output Noise Voltage	V_N	$f = 10\text{Hz to } 100\text{KHz}$ $T_A = +25^{\circ}\text{C}$	-	10	-	$\mu\text{V}/V_O$	
Ripple Rejection	RR	$f = 120\text{Hz}$, $I_O = 500\text{mA}$ $V_I = 8\text{V to } 18\text{V}$	-	68	-	dB	
Dropout Voltage	V_{Drop}	$I_O = 1\text{A}$, $T_J = +25^{\circ}\text{C}$	-	2	-	V	
Output Resistance	r_O	$f = 1\text{KHz}$	-	17	-	$\text{m}\Omega$	
Short Circuit Current	ISC	$V_I = 35\text{V}$, $T_A = +25^{\circ}\text{C}$	-	250	-	mA	
Peak Current	IPK	$T_J = +25^{\circ}\text{C}$	-	2.2	-	A	

Note:

1. Load and line regulation are specified at constant junction temperature. Change in V_O due to heating effects must be taken into account separately. Pulse testing with low duty is used.

Electrical Characteristics (KA7806A)

(Refer to the test circuits. $0^{\circ}\text{C} < T_J < +125^{\circ}\text{C}$, $I_O = 1\text{A}$, $V_I = 11\text{V}$, $C_I = 0.33\mu\text{F}$, $C_O = 0.1\mu\text{F}$, unless otherwise specified)

Parameter	Symbol	Conditions	Min.	Typ.	Max.	Unit	
Output Voltage	V_O	$T_J = +25^{\circ}\text{C}$	5.58	6	6.12	V	
		$I_O = 5\text{mA}$ to 1A, $P_O \leq 15\text{W}$ $V_I = 8.6\text{V}$ to 21V	5.76	6	6.24		
Line Regulation (Note1)	Regline	$V_I = 8.6\text{V}$ to 25V $I_O = 500\text{mA}$	-	5	60	mV	
		$V_I = 9\text{V}$ to 13V	-	3	60		
		$T_J = +25^{\circ}\text{C}$	$V_I = 8.3\text{V}$ to 21V	-	5		60
			$V_I = 9\text{V}$ to 13V	-	1.5		30
Load Regulation (Note1)	Regload	$T_J = +25^{\circ}\text{C}$ $I_O = 5\text{mA}$ to 1.5A	-	9	100	mV	
		$I_O = 5\text{mA}$ to 1A	-	4	100		
		$I_O = 250\text{mA}$ to 750mA	-	5.0	50		
Quiescent Current	I_Q	$T_J = +25^{\circ}\text{C}$	-	4.3	6.0	mA	
Quiescent Current Change	ΔI_Q	$I_O = 5\text{mA}$ to 1A	-	-	0.5	mA	
		$V_I = 9\text{V}$ to 25V, $I_O = 500\text{mA}$	-	-	0.8		
		$V_I = 8.5\text{V}$ to 21V, $T_J = +25^{\circ}\text{C}$	-	-	0.8		
Output Voltage Drift	$\Delta V/\Delta T$	$I_O = 5\text{mA}$	-	-0.8	-	mV/ $^{\circ}\text{C}$	
Output Noise Voltage	V_N	$f = 10\text{Hz}$ to 100KHz $T_A = +25^{\circ}\text{C}$	-	10	-	$\mu\text{V}/V_O$	
Ripple Rejection	RR	$f = 120\text{Hz}$, $I_O = 500\text{mA}$ $V_I = 9\text{V}$ to 19V	-	65	-	dB	
Dropout Voltage	V_{Drop}	$I_O = 1\text{A}$, $T_J = +25^{\circ}\text{C}$	-	2	-	V	
Output Resistance	r_O	$f = 1\text{KHz}$	-	17	-	$\text{m}\Omega$	
Short Circuit Current	ISC	$V_I = 35\text{V}$, $T_A = +25^{\circ}\text{C}$	-	250	-	mA	
Peak Current	IPK	$T_J = +25^{\circ}\text{C}$	-	2.2	-	A	

Note:

1. Load and line regulation are specified at constant junction temperature. Change in V_O due to heating effects must be taken into account separately. Pulse testing with low duty is used.

Electrical Characteristics (KA7808A)

(Refer to the test circuits. $0^{\circ}\text{C} < T_J < +125^{\circ}\text{C}$, $I_O = 1\text{A}$, $V_I = 14\text{V}$, $C_I = 0.33\mu\text{F}$, $C_O = 0.1\mu\text{F}$, unless otherwise specified)

Parameter	Symbol	Conditions	Min.	Typ.	Max.	Unit	
Output Voltage	V_O	$T_J = +25^{\circ}\text{C}$	7.84	8	8.16	V	
		$I_O = 5\text{mA to } 1\text{A}$, $P_O \leq 15\text{W}$ $V_I = 10.6\text{V to } 23\text{V}$	7.7	8	8.3		
Line Regulation (Note1)	Regline	$V_I = 10.6\text{V to } 25\text{V}$ $I_O = 500\text{mA}$	-	6	80	mV	
		$V_I = 11\text{V to } 17\text{V}$	-	3	80		
		$T_J = +25^{\circ}\text{C}$	$V_I = 10.4\text{V to } 23\text{V}$	-	6		80
			$V_I = 11\text{V to } 17\text{V}$	-	2		40
Load Regulation (Note1)	Regload	$T_J = +25^{\circ}\text{C}$ $I_O = 5\text{mA to } 1.5\text{A}$	-	12	100	mV	
		$I_O = 5\text{mA to } 1\text{A}$	-	12	100		
		$I_O = 250\text{mA to } 750\text{mA}$	-	5	50		
Quiescent Current	I_Q	$T_J = +25^{\circ}\text{C}$	-	5.0	6.0	mA	
Quiescent Current Change	ΔI_Q	$I_O = 5\text{mA to } 1\text{A}$	-	-	0.5	mA	
		$V_I = 11\text{V to } 25\text{V}$, $I_O = 500\text{mA}$	-	-	0.8		
		$V_I = 10.6\text{V to } 23\text{V}$, $T_J = +25^{\circ}\text{C}$	-	-	0.8		
Output Voltage Drift	$\Delta V/\Delta T$	$I_O = 5\text{mA}$	-	-0.8	-	mV/ $^{\circ}\text{C}$	
Output Noise Voltage	V_N	$f = 10\text{Hz to } 100\text{KHz}$ $T_A = +25^{\circ}\text{C}$	-	10	-	$\mu\text{V}/V_O$	
Ripple Rejection	RR	$f = 120\text{Hz}$, $I_O = 500\text{mA}$ $V_I = 11.5\text{V to } 21.5\text{V}$	-	62	-	dB	
Dropout Voltage	V_{Drop}	$I_O = 1\text{A}$, $T_J = +25^{\circ}\text{C}$	-	2	-	V	
Output Resistance	r_O	$f = 1\text{KHz}$	-	18	-	$\text{m}\Omega$	
Short Circuit Current	ISC	$V_I = 35\text{V}$, $T_A = +25^{\circ}\text{C}$	-	250	-	mA	
Peak Current	IPK	$T_J = +25^{\circ}\text{C}$	-	2.2	-	A	

Note:

1. Load and line regulation are specified at constant junction temperature. Change in V_O due to heating effects must be taken into account separately. Pulse testing with low duty is used.

Electrical Characteristics (KA7809A)

(Refer to the test circuits. $0^{\circ}\text{C} < T_J < +125^{\circ}\text{C}$, $I_O = 1\text{A}$, $V_I = 15\text{V}$, $C_I = 0.33\mu\text{F}$, $C_O = 0.1\mu\text{F}$, unless otherwise specified)

Parameter	Symbol	Conditions	Min.	Typ.	Max.	Unit	
Output Voltage	V_O	$T_J = +25^{\circ}\text{C}$	8.82	9.0	9.18	V	
		$I_O = 5\text{mA to } 1\text{A}$, $P_O \leq 15\text{W}$ $V_I = 11.2\text{V to } 24\text{V}$	8.65	9.0	9.35		
Line Regulation (Note1)	Regline	$V_I = 11.7\text{V to } 25\text{V}$ $I_O = 500\text{mA}$	-	6	90	mV	
		$V_I = 12.5\text{V to } 19\text{V}$	-	4	45		
		$T_J = +25^{\circ}\text{C}$	$V_I = 11.5\text{V to } 24\text{V}$	-	6		90
			$V_I = 12.5\text{V to } 19\text{V}$	-	2		45
Load Regulation (Note1)	Regload	$T_J = +25^{\circ}\text{C}$ $I_O = 5\text{mA to } 1.0\text{A}$	-	12	100	mV	
		$I_O = 5\text{mA to } 1.0\text{A}$	-	12	100		
		$I_O = 250\text{mA to } 750\text{mA}$	-	5	50		
Quiescent Current	I_Q	$T_J = +25^{\circ}\text{C}$	-	5.0	6.0	mA	
Quiescent Current Change	ΔI_Q	$V_I = 11.7\text{V to } 25\text{V}$, $T_J = +25^{\circ}\text{C}$	-	-	0.8	mA	
		$V_I = 12\text{V to } 25\text{V}$, $I_O = 500\text{mA}$	-	-	0.8		
		$I_O = 5\text{mA to } 1.0\text{A}$	-	-	0.5		
Output Voltage Drift	$\Delta V/\Delta T$	$I_O = 5\text{mA}$	-	-1.0	-	mV/ $^{\circ}\text{C}$	
Output Noise Voltage	V_N	$f = 10\text{Hz to } 100\text{KHz}$ $T_A = +25^{\circ}\text{C}$	-	10	-	$\mu\text{V}/V_O$	
Ripple Rejection	RR	$f = 120\text{Hz}$, $I_O = 500\text{mA}$ $V_I = 12\text{V to } 22\text{V}$	-	62	-	dB	
Dropout Voltage	V_{Drop}	$I_O = 1\text{A}$, $T_J = +25^{\circ}\text{C}$	-	2.0	-	V	
Output Resistance	r_O	$f = 1\text{KHz}$	-	17	-	$\text{m}\Omega$	
Short Circuit Current	ISC	$V_I = 35\text{V}$, $T_A = +25^{\circ}\text{C}$	-	250	-	mA	
Peak Current	I_{PK}	$T_J = +25^{\circ}\text{C}$	-	2.2	-	A	

Note:

1. Load and line regulation are specified at constant junction temperature. Change in V_O due to heating effects must be taken into account separately. Pulse testing with low duty is used.

Electrical Characteristics (KA7810A)

(Refer to the test circuits. $0^{\circ}\text{C} < T_J < +125^{\circ}\text{C}$, $I_O = 1\text{A}$, $V_I = 16\text{V}$, $C_I = 0.33\mu\text{F}$, $C_O = 0.1\mu\text{F}$, unless otherwise specified)

Parameter	Symbol	Conditions	Min.	Typ.	Max.	Unit	
Output Voltage	V_O	$T_J = +25^{\circ}\text{C}$	9.8	10	10.2	V	
		$I_O = 5\text{mA to } 1\text{A}$, $P_O \leq 15\text{W}$ $V_I = 12.8\text{V to } 25\text{V}$	9.6	10	10.4		
Line Regulation (Note1)	Regline	$V_I = 12.8\text{V to } 26\text{V}$ $I_O = 500\text{mA}$	-	8	100	mV	
		$V_I = 13\text{V to } 20\text{V}$	-	4	50		
		$T_J = +25^{\circ}\text{C}$	$V_I = 12.5\text{V to } 25\text{V}$	-	8		100
			$V_I = 13\text{V to } 20\text{V}$	-	3		50
Load Regulation (Note1)	Regload	$T_J = +25^{\circ}\text{C}$ $I_O = 5\text{mA to } 1.5\text{A}$	-	12	100	mV	
		$I_O = 5\text{mA to } 1.0\text{A}$	-	12	100		
		$I_O = 250\text{mA to } 750\text{mA}$	-	5	50		
Quiescent Current	I_Q	$T_J = +25^{\circ}\text{C}$	-	5.0	6.0	mA	
Quiescent Current Change	ΔI_Q	$V_I = 13\text{V to } 26\text{V}$, $T_J = +25^{\circ}\text{C}$	-	-	0.5	mA	
		$V_I = 12.8\text{V to } 25\text{V}$, $I_O = 500\text{mA}$	-	-	0.8		
		$I_O = 5\text{mA to } 1.0\text{A}$	-	-	0.5		
Output Voltage Drift	$\Delta V/\Delta T$	$I_O = 5\text{mA}$	-	-1.0	-	mV/ $^{\circ}\text{C}$	
Output Noise Voltage	V_N	$f = 10\text{Hz to } 100\text{kHz}$ $T_A = +25^{\circ}\text{C}$	-	10	-	$\mu\text{V}/V_O$	
Ripple Rejection	RR	$f = 120\text{Hz}$, $I_O = 500\text{mA}$ $V_I = 14\text{V to } 24\text{V}$	-	62	-	dB	
Dropout Voltage	V_{Drop}	$I_O = 1\text{A}$, $T_J = +25^{\circ}\text{C}$	-	2.0	-	V	
Output Resistance	r_O	$f = 1\text{kHz}$	-	17	-	$\text{m}\Omega$	
Short Circuit Current	ISC	$V_I = 35\text{V}$, $T_A = +25^{\circ}\text{C}$	-	250	-	mA	
Peak Current	IPK	$T_J = +25^{\circ}\text{C}$	-	2.2	-	A	

Note:

1. Load and line regulation are specified at constant junction temperature. Change in V_O due to heating effects must be taken into account separately. Pulse testing with low duty is used.

Electrical Characteristics (KA7812A)

(Refer to the test circuits. $0^{\circ}\text{C} < T_J < +125^{\circ}\text{C}$, $I_O = 1\text{A}$, $V_I = 19\text{V}$, $C_I = 0.33\mu\text{F}$, $C_O = 0.1\mu\text{F}$, unless otherwise specified)

Parameter	Symbol	Conditions	Min.	Typ.	Max.	Unit	
Output Voltage	V_O	$T_J = +25^{\circ}\text{C}$	11.75	12	12.25	V	
		$I_O = 5\text{mA to } 1\text{A}$, $P_O \leq 15\text{W}$ $V_I = 14.8\text{V to } 27\text{V}$	11.5	12	12.5		
Line Regulation (Note1)	Regline	$V_I = 14.8\text{V to } 30\text{V}$ $I_O = 500\text{mA}$	-	10	120	mV	
		$V_I = 16\text{V to } 22\text{V}$	-	4	120		
		$T_J = +25^{\circ}\text{C}$					
		$V_I = 14.5\text{V to } 27\text{V}$ $V_I = 16\text{V to } 22\text{V}$	-	10	120		-
Load Regulation (Note1)	Regload	$T_J = +25^{\circ}\text{C}$ $I_O = 5\text{mA to } 1.5\text{A}$	-	12	100	mV	
		$I_O = 5\text{mA to } 1.0\text{A}$	-	12	100		
		$I_O = 250\text{mA to } 750\text{mA}$	-	5	50		
Quiescent Current	I_Q	$T_J = +25^{\circ}\text{C}$	-	5.1	6.0	mA	
Quiescent Current Change	ΔI_Q	$V_I = 15\text{V to } 30\text{V}$, $T_J = +25^{\circ}\text{C}$	-	-	0.8	mA	
		$V_I = 14\text{V to } 27\text{V}$, $I_O = 500\text{mA}$	-	-	0.8		
		$I_O = 5\text{mA to } 1.0\text{A}$	-	-	0.5		
Output Voltage Drift	$\Delta V/\Delta T$	$I_O = 5\text{mA}$	-	-1.0	-	$\text{mV}/^{\circ}\text{C}$	
Output Noise Voltage	V_N	$f = 10\text{Hz to } 100\text{KHz}$ $T_A = +25^{\circ}\text{C}$	-	10	-	$\mu\text{V}/V_O$	
Ripple Rejection	RR	$f = 120\text{Hz}$, $I_O = 500\text{mA}$ $V_I = 14\text{V to } 24\text{V}$	-	60	-	dB	
Dropout Voltage	V_{Drop}	$I_O = 1\text{A}$, $T_J = +25^{\circ}\text{C}$	-	2.0	-	V	
Output Resistance	r_O	$f = 1\text{KHz}$	-	18	-	$\text{m}\Omega$	
Short Circuit Current	ISC	$V_I = 35\text{V}$, $T_A = +25^{\circ}\text{C}$	-	250	-	mA	
Peak Current	IPK	$T_J = +25^{\circ}\text{C}$	-	2.2	-	A	

Note:

1. Load and line regulation are specified at constant junction temperature. Change in V_O due to heating effects must be taken into account separately. Pulse testing with low duty is used.

Electrical Characteristics (KA7815A)

(Refer to the test circuits. $0^{\circ}\text{C} < T_J < +125^{\circ}\text{C}$, $I_O = 1\text{A}$, $V_I = 23\text{V}$, $C_I = 0.33\mu\text{F}$, $C_O = 0.1\mu\text{F}$, unless otherwise specified)

Parameter	Symbol	Conditions	Min.	Typ.	Max.	Unit	
Output Voltage	V_O	$T_J = +25^{\circ}\text{C}$	14.7	15	15.3	V	
		$I_O = 5\text{mA}$ to 1A, $P_O \leq 15\text{W}$ $V_I = 17.7\text{V}$ to 30V	14.4	15	15.6		
Line Regulation (Note1)	Regline	$V_I = 17.9\text{V}$ to 30V $I_O = 500\text{mA}$	-	10	150	mV	
		$V_I = 20\text{V}$ to 26V	-	5	150		
		$T_J = +25^{\circ}\text{C}$	$V_I = 17.5\text{V}$ to 30V	-	11		150
			$V_I = 20\text{V}$ to 26V	-	3		75
Load Regulation (Note1)	Regload	$T_J = +25^{\circ}\text{C}$ $I_O = 5\text{mA}$ to 1.5A	-	12	100	mV	
		$I_O = 5\text{mA}$ to 1.0A	-	12	100		
		$I_O = 250\text{mA}$ to 750mA	-	5	50		
Quiescent Current	I_Q	$T_J = +25^{\circ}\text{C}$	-	5.2	6.0	mA	
Quiescent Current Change	ΔI_Q	$V_I = 17.5\text{V}$ to 30V, $T_J = +25^{\circ}\text{C}$	-	-	0.8	mA	
		$V_I = 17.5\text{V}$ to 30V, $I_O = 500\text{mA}$	-	-	0.8		
		$I_O = 5\text{mA}$ to 1.0A	-	-	0.5		
Output Voltage Drift	$\Delta V/\Delta T$	$I_O = 5\text{mA}$	-	-1.0	-	$\text{mV}/^{\circ}\text{C}$	
Output Noise Voltage	V_N	$f = 10\text{Hz}$ to 100KHz $T_A = +25^{\circ}\text{C}$	-	10	-	$\mu\text{V}/V_O$	
Ripple Rejection	RR	$f = 120\text{Hz}$, $I_O = 500\text{mA}$ $V_I = 18.5\text{V}$ to 28.5V	-	58	-	dB	
Dropout Voltage	V_{Drop}	$I_O = 1\text{A}$, $T_J = +25^{\circ}\text{C}$	-	2.0	-	V	
Output Resistance	r_O	$f = 1\text{KHz}$	-	19	-	$\text{m}\Omega$	
Short Circuit Current	ISC	$V_I = 35\text{V}$, $T_A = +25^{\circ}\text{C}$	-	250	-	mA	
Peak Current	IPK	$T_J = +25^{\circ}\text{C}$	-	2.2	-	A	

Note:

1. Load and line regulation are specified at constant junction temperature. Change in V_O due to heating effects must be taken into account separately. Pulse testing with low duty is used.

Electrical Characteristics (KA7818A)

(Refer to the test circuits. $0^{\circ}\text{C} < T_J < +125^{\circ}\text{C}$, $I_O = 1\text{A}$, $V_I = 27\text{V}$, $C_I = 0.33\mu\text{F}$, $C_O = 0.1\mu\text{F}$, unless otherwise specified)

Parameter	Symbol	Conditions	Min.	Typ.	Max.	Unit	
Output Voltage	V_O	$T_J = +25^{\circ}\text{C}$	17.64	18	18.36	V	
		$I_O = 5\text{mA to } 1\text{A}$, $P_O \leq 15\text{W}$ $V_I = 21\text{V to } 33\text{V}$	17.3	18	18.7		
Line Regulation (Note1)	Regline	$V_I = 21\text{V to } 33\text{V}$ $I_O = 500\text{mA}$	-	15	180	mV	
		$V_I = 21\text{V to } 33\text{V}$	-	5	180		
		$T_J = +25^{\circ}\text{C}$	$V_I = 20.6\text{V to } 33\text{V}$	-	15		180
			$V_I = 24\text{V to } 30\text{V}$	-	5		90
Load Regulation (Note1)	Regload	$T_J = +25^{\circ}\text{C}$ $I_O = 5\text{mA to } 1.5\text{A}$	-	15	100	mV	
		$I_O = 5\text{mA to } 1.0\text{A}$	-	15	100		
		$I_O = 250\text{mA to } 750\text{mA}$	-	7	50		
Quiescent Current	I_Q	$T_J = +25^{\circ}\text{C}$	-	5.2	6.0	mA	
Quiescent Current Change	ΔI_Q	$V_I = 21\text{V to } 33\text{V}$, $T_J = +25^{\circ}\text{C}$	-	-	0.8	mA	
		$V_I = 21\text{V to } 33\text{V}$, $I_O = 500\text{mA}$	-	-	0.8		
		$I_O = 5\text{mA to } 1.0\text{A}$	-	-	0.5		
Output Voltage Drift	$\Delta V/\Delta T$	$I_O = 5\text{mA}$	-	-1.0	-	mV/ $^{\circ}\text{C}$	
Output Noise Voltage	V_N	$f = 10\text{Hz to } 100\text{kHz}$ $T_A = +25^{\circ}\text{C}$	-	10	-	$\mu\text{V}/V_O$	
Ripple Rejection	RR	$f = 120\text{Hz}$, $I_O = 500\text{mA}$ $V_I = 22\text{V to } 32\text{V}$	-	57	-	dB	
Dropout Voltage	V_{Drop}	$I_O = 1\text{A}$, $T_J = +25^{\circ}\text{C}$	-	2.0	-	V	
Output Resistance	r_O	$f = 1\text{kHz}$	-	19	-	$\text{m}\Omega$	
Short Circuit Current	ISC	$V_I = 35\text{V}$, $T_A = +25^{\circ}\text{C}$	-	250	-	mA	
Peak Current	IPK	$T_J = +25^{\circ}\text{C}$	-	2.2	-	A	

Note:

1. Load and line regulation are specified at constant junction temperature. Change in V_O due to heating effects must be taken into account separately. Pulse testing with low duty is used.

Electrical Characteristics (KA7824A)

(Refer to the test circuits. $0^{\circ}\text{C} < T_J < +125^{\circ}\text{C}$, $I_O = 1\text{A}$, $V_I = 33\text{V}$, $C_I = 0.33\mu\text{F}$, $C_O = 0.1\mu\text{F}$, unless otherwise specified)

Parameter	Symbol	Conditions	Min.	Typ.	Max.	Unit	
Output Voltage	V_O	$T_J = +25^{\circ}\text{C}$	23.5	24	24.5	V	
		$I_O = 5\text{mA}$ to 1A , $P_O \leq 15\text{W}$ $V_I = 27.3\text{V}$ to 38V	23	24	25		
Line Regulation (Note1)	Regline	$V_I = 27\text{V}$ to 38V $I_O = 500\text{mA}$	-	18	240	mV	
		$V_I = 21\text{V}$ to 33V	-	6	240		
		$T_J = +25^{\circ}\text{C}$	$V_I = 26.7\text{V}$ to 38V	-	18		240
			$V_I = 30\text{V}$ to 36V	-	6		120
Load Regulation (Note1)	Regload	$T_J = +25^{\circ}\text{C}$ $I_O = 5\text{mA}$ to 1.5A	-	15	100	mV	
		$I_O = 5\text{mA}$ to 1.0A	-	15	100		
		$I_O = 250\text{mA}$ to 750mA	-	7	50		
Quiescent Current	I_Q	$T_J = +25^{\circ}\text{C}$	-	5.2	6.0	mA	
Quiescent Current Change	ΔI_Q	$V_I = 27.3\text{V}$ to 38V , $T_J = +25^{\circ}\text{C}$	-	-	0.8	mA	
		$V_I = 27.3\text{V}$ to 38V , $I_O = 500\text{mA}$	-	-	0.8		
		$I_O = 5\text{mA}$ to 1.0A	-	-	0.5		
Output Voltage Drift	$\Delta V/\Delta T$	$I_O = 5\text{mA}$	-	-1.5	-	mV/ $^{\circ}\text{C}$	
Output Noise Voltage	V_N	$f = 10\text{Hz}$ to 100kHz $T_A = 25^{\circ}\text{C}$	-	10	-	$\mu\text{V}/V_O$	
Ripple Rejection	RR	$f = 120\text{Hz}$, $I_O = 500\text{mA}$ $V_I = 28\text{V}$ to 38V	-	54	-	dB	
Dropout Voltage	V_{Drop}	$I_O = 1\text{A}$, $T_J = +25^{\circ}\text{C}$	-	2.0	-	V	
Output Resistance	r_O	$f = 1\text{kHz}$	-	20	-	$\text{m}\Omega$	
Short Circuit Current	ISC	$V_I = 35\text{V}$, $T_A = +25^{\circ}\text{C}$	-	250	-	mA	
Peak Current	IPK	$T_J = +25^{\circ}\text{C}$	-	2.2	-	A	

Note:

1. Load and line regulation are specified at constant junction temperature. Change in V_O due to heating effects must be taken into account separately. Pulse testing with low duty is used.

Typical Performance Characteristics

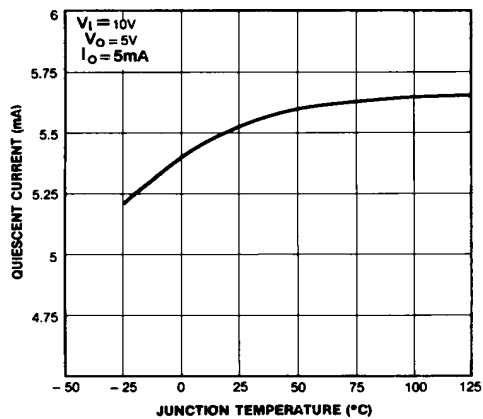

Figure 1. Quiescent Current

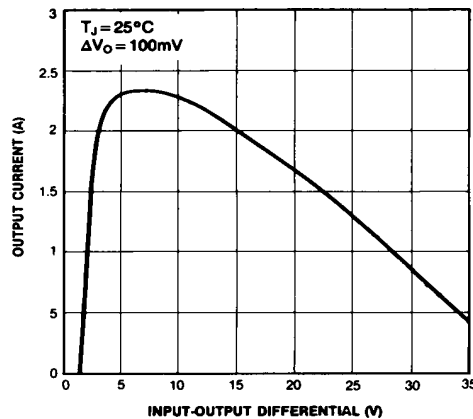

Figure 2. Peak Output Current

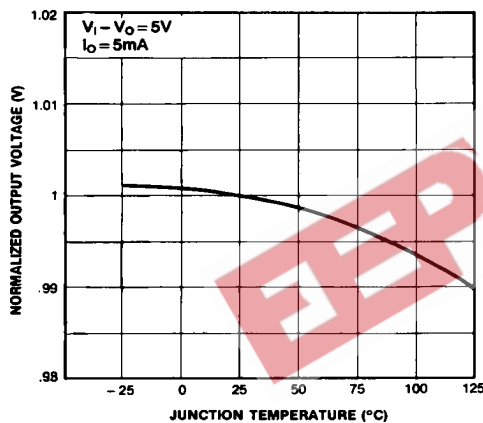

Figure 3. Output Voltage

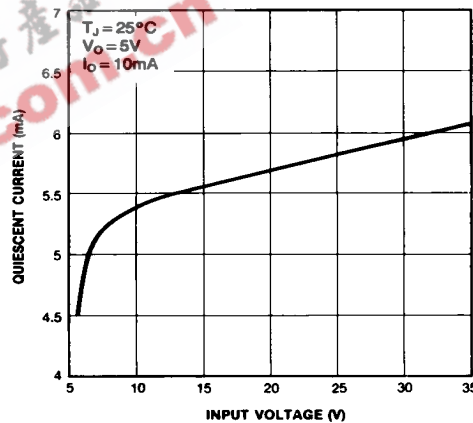

Figure 4. Quiescent Current

Typical Applications

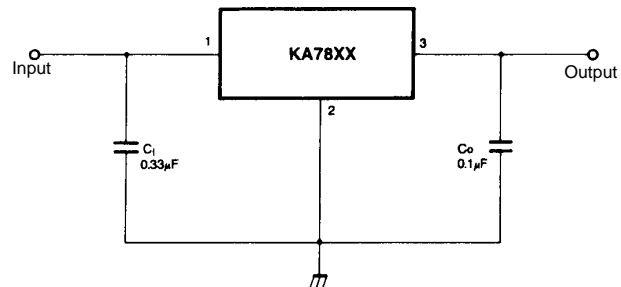

Figure 5. DC Parameters

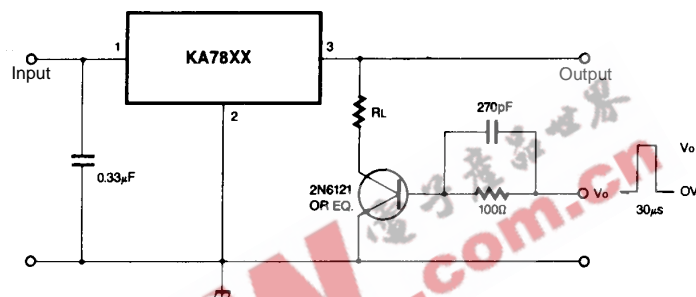

Figure 6. Load Regulation

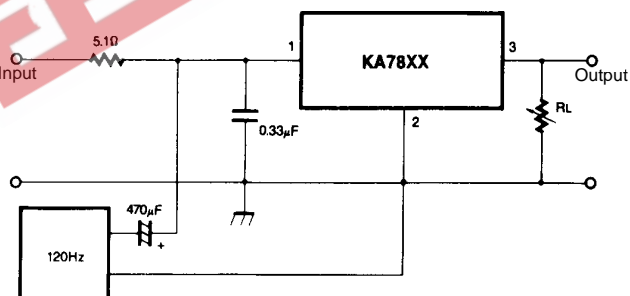

Figure 7. Ripple Rejection

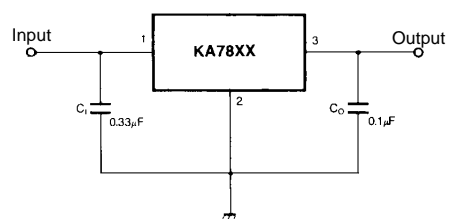

Figure 8. Fixed Output Regulator

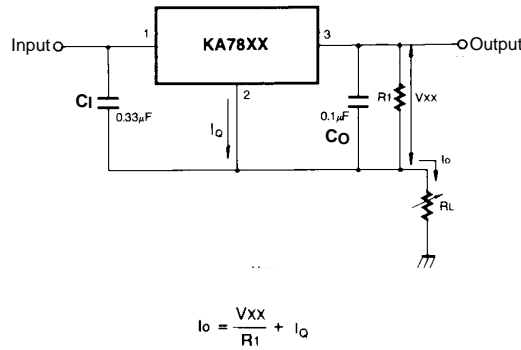
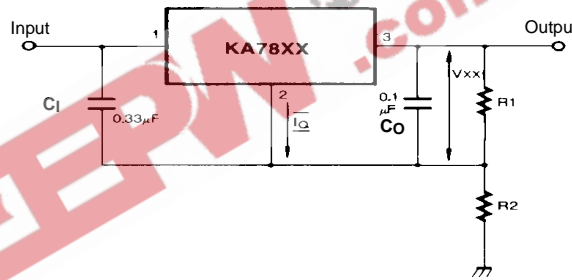

Figure 9. Constant Current Regulator

Notes:

- (1) To specify an output voltage, substitute voltage value for "XX." A common ground is required between the input and the Output voltage. The input voltage must remain typically 2.0V above the output voltage even during the low point on the input ripple voltage.
- (2) C₁ is required if regulator is located an appreciable distance from power Supply filter.
- (3) C₀ improves stability and transient response.



$$I_{R1} \geq 5I_Q$$

$$V_O = V_{XX}(1+R_2/R_1)+I_Q R_2$$

Figure 10. Circuit for Increasing Output Voltage

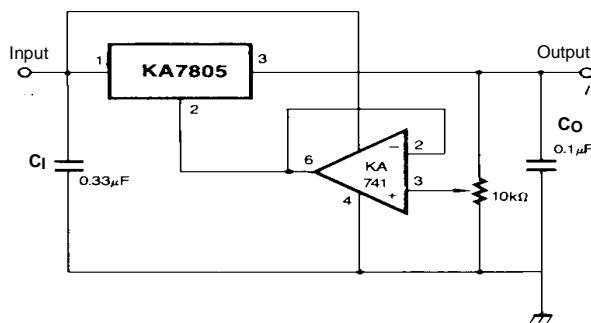

$$I_{R1} \geq 5 I_Q$$

$$V_O = V_{XX}(1+R_2/R_1)+I_Q R_2$$

Figure 11. Adjustable Output Regulator (7 to 30V)

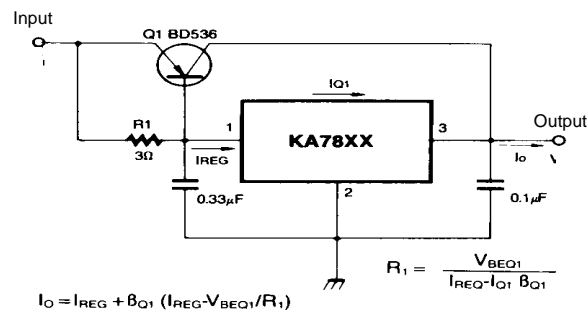

Figure 12. High Current Voltage Regulator

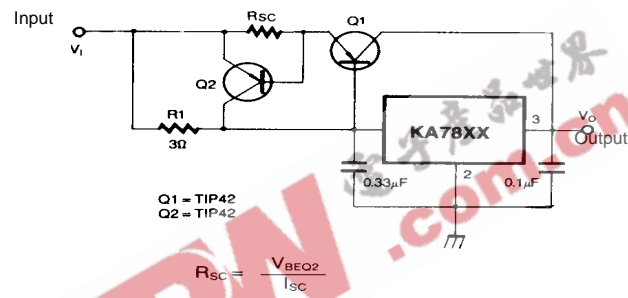

Figure 13. High Output Current with Short Circuit Protection

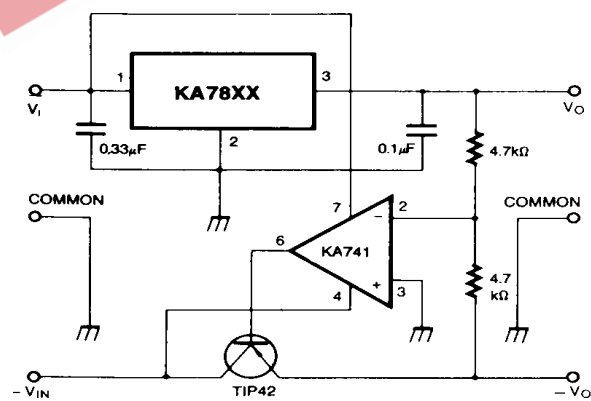

Figure 14. Tracking Voltage Regulator

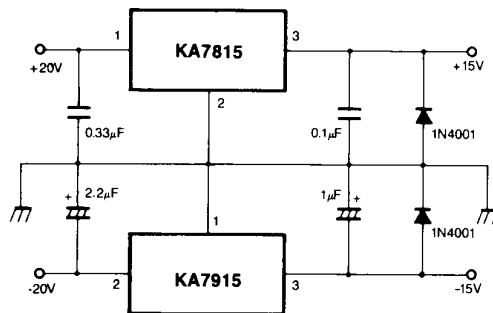

Figure 15. Split Power Supply (±15V-1A)

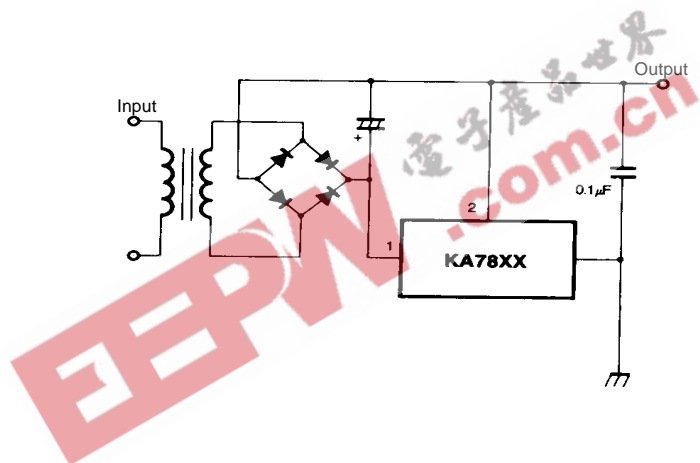

Figure 16. Negative Output Voltage Circuit

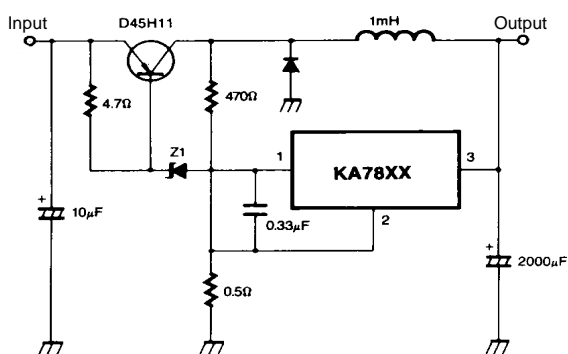
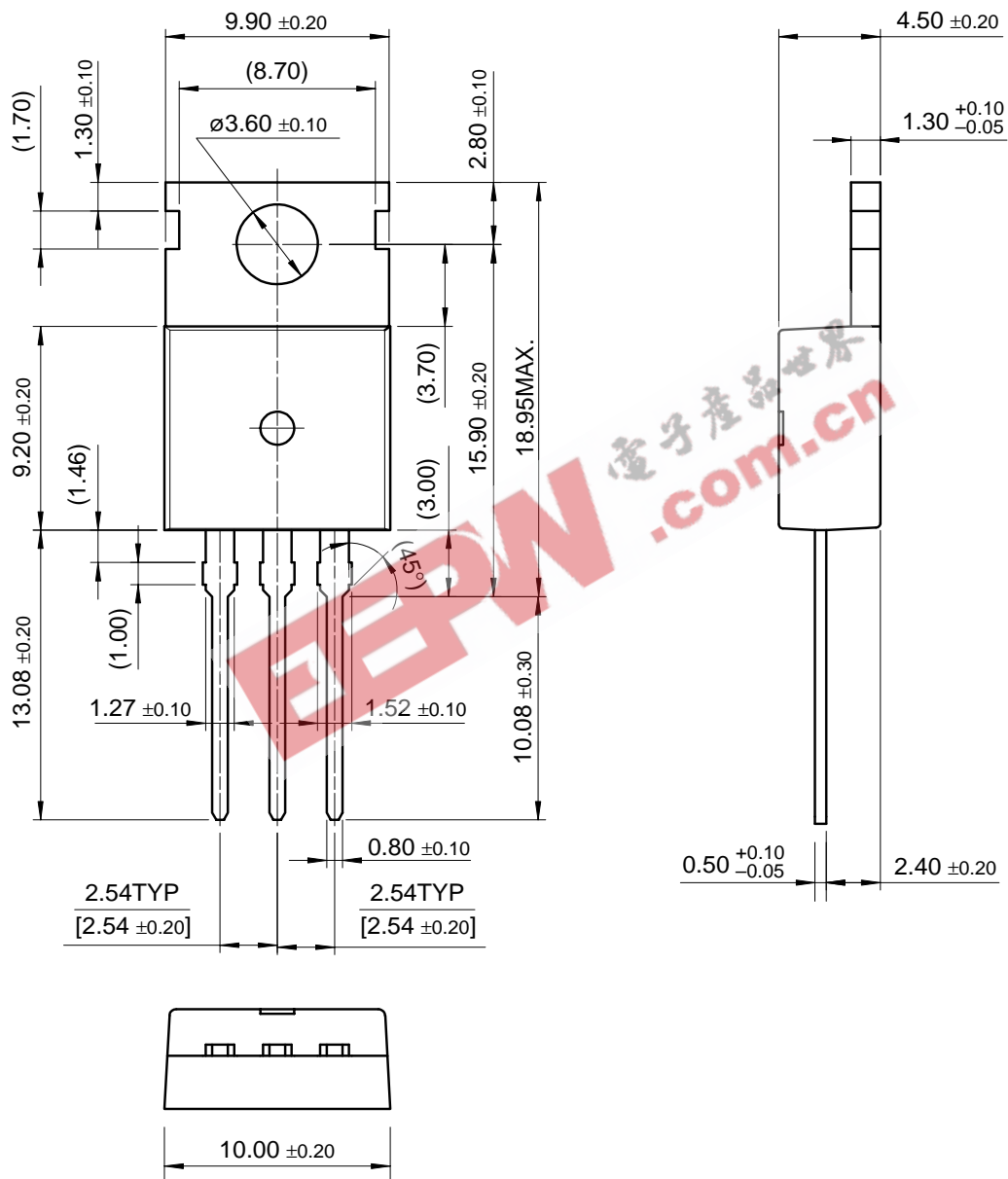

Figure 17. Switching Regulator

Mechanical Dimensions

Package

TO-220



Mechanical Dimensions (Continued)

Package

D-PAK

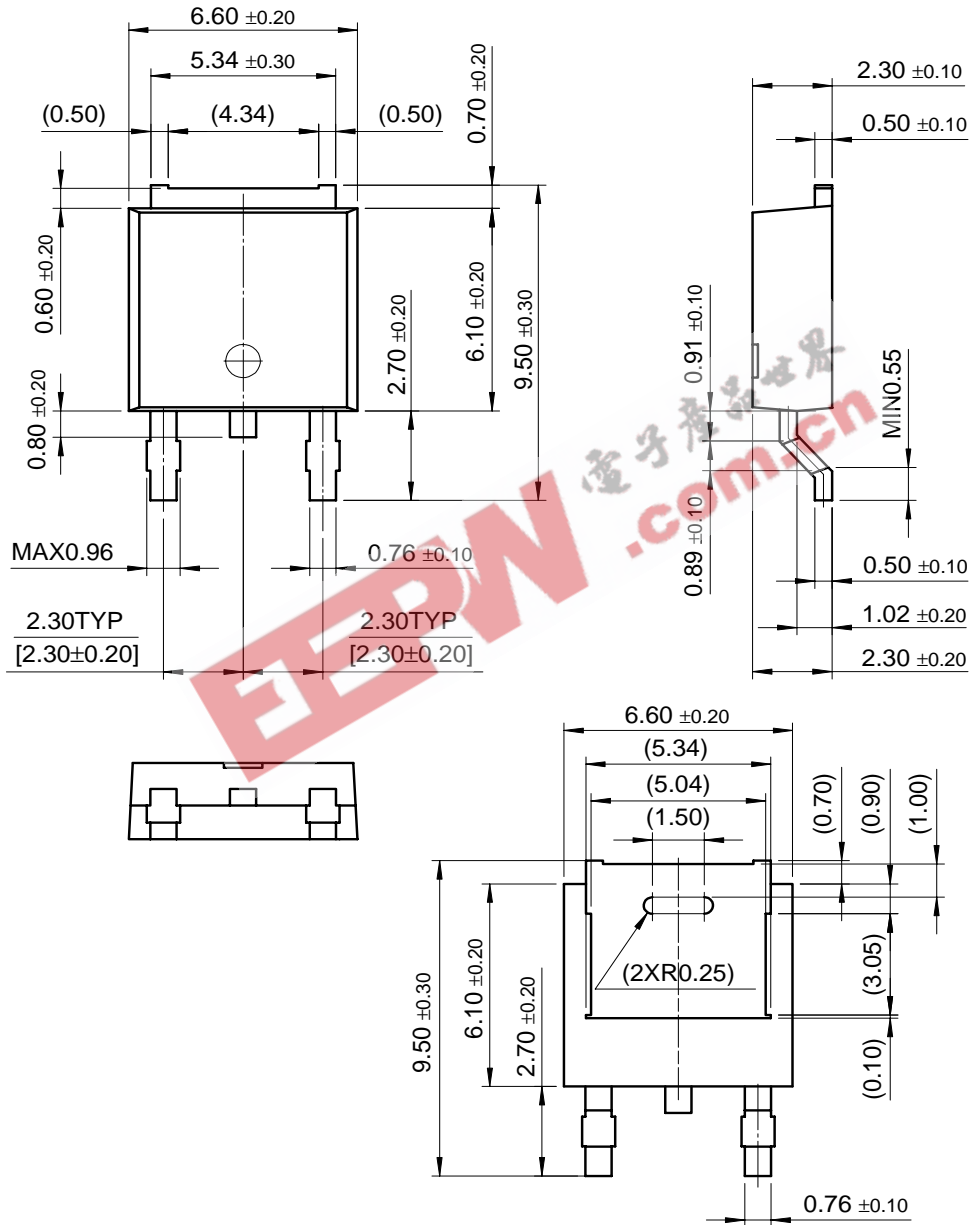

Ordering Information

Product Number	Output Voltage Tolerance	Package	Operating Temperature
KA7805 / KA7806	±4%	TO-220	0 ~ + 125°C
KA7808 / KA7809			
KA7810			
KA7812 / KA7815			
KA7818 / KA7824			
KA7805A / KA7806A	±2%		
KA7808A / KA7809A			
KA7810A / KA7812A			
KA7815A / KA7818A			
KA7824A			
KA7805R / KA7806R	±4%	D-PAK	
KA7808R / KA7809R			
KA7812R			

EEPW 电子产品世界
www.eepw.com.cn



DISCLAIMER

FAIRCHILD SEMICONDUCTOR RESERVES THE RIGHT TO MAKE CHANGES WITHOUT FURTHER NOTICE TO ANY PRODUCTS HEREIN TO IMPROVE RELIABILITY, FUNCTION OR DESIGN. FAIRCHILD DOES NOT ASSUME ANY LIABILITY ARISING OUT OF THE APPLICATION OR USE OF ANY PRODUCT OR CIRCUIT DESCRIBED HEREIN; NEITHER DOES IT CONVEY ANY LICENSE UNDER ITS PATENT RIGHTS, NOR THE RIGHTS OF OTHERS.

LIFE SUPPORT POLICY

FAIRCHILD'S PRODUCTS ARE NOT AUTHORIZED FOR USE AS CRITICAL COMPONENTS IN LIFE SUPPORT DEVICES OR SYSTEMS WITHOUT THE EXPRESS WRITTEN APPROVAL OF THE PRESIDENT OF FAIRCHILD SEMICONDUCTOR CORPORATION. As used herein:

1. Life support devices or systems are devices or systems which, (a) are intended for surgical implant into the body, or (b) support or sustain life, and (c) whose failure to perform when properly used in accordance with instructions for use provided in the labeling, can be reasonably expected to result in a significant injury of the user.
2. A critical component in any component of a life support device or system whose failure to perform can be reasonably expected to cause the failure of the life support device or system, or to affect its safety or effectiveness.