



GENERAL DESCRIPTION



The ICS843051 is a Gb Ethernet Generator and a member of the HiPerClocks™ family of high performance devices from ICS. The ICS843051 can synthesize 10 Gigabit Ethernet, SONET, or Serial ATA reference clock frequencies with the appropriate choice of crystal and output divider. The ICS843051 has excellent phase jitter performance and is packaged in a small 8-pin TSSOP, making it ideal for use in systems with limited board space.

FEATURES

- 1 differential 3.3V LVPECL output
- Crystal oscillator interface designed for 18pF parallel resonant crystals
- RMS phase jitter at:
 - 155.52MHz (12KHz - 20MHz): 0.74ps (typical)
 - 156.25MHz (1.875MHz - 20MHz): 0.43ps (typical)
 - 161.13MHz (1.933MHz - 20MHz): 0.43ps (typical)
- RMS phase noise at 156.25MHz

Offset	Noise Power
100Hz	-95 dBc/Hz
1KHz	-110 dBc/Hz
10KHz	-125 dBc/Hz
100KHz	-125 dBc/Hz
- 3.3V operating supply
- 0°C to 70°C ambient operating temperature
- Industrial temperature information available upon request
- Lead-Free package fully RoHS compliant

FREQUENCY TABLE

Inputs		Output Frequency (MHz)
Crystal Frequency (MHz)	FREQ_SEL	
20.141601	0	161.132812
20.141601	1	80.566406
19.53125	0	156.25
19.53125	1	78.125
19.44	0	155.52
19.44	1	77.76
18.75	0	150
18.75	1	75

PIN ASSIGNMENT

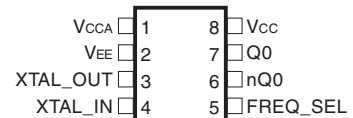

ICS843051

8-Lead TSSOP
4.40mm x 3.0mm x 0.925mm
package body
G Package
Top View

BLOCK DIAGRAM

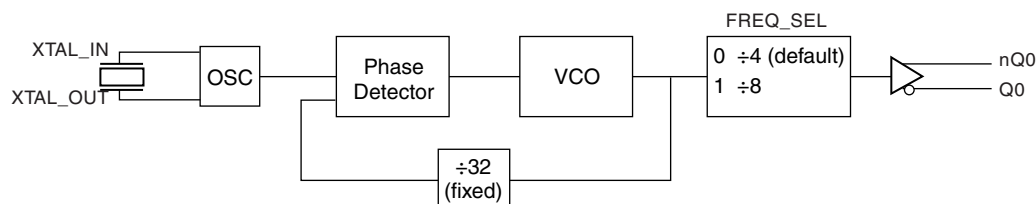



TABLE 1. PIN DESCRIPTIONS

Number	Name	Type	Description
1	V _{CCA}	Power	Analog supply pin.
2	V _{EE}	Power	Negative supply pin.
3, 4	XTAL_OUT, XTAL_IN	Input	Crystal oscillator interface. XTAL_IN is the input, XTAL_OUT is the output.
5	FREQ_SEL	Input Pulldown	Frequency select pin. LVCMOS/LVTTL interface levels.
6, 7	nQ0, Q0	Output	Differential clock outputs. LVPECL interface levels.
8	V _{CC}	Power	Core supply pin.

NOTE: Pulldown refers to internal input resistors. See Table 2, Pin Characteristics, for typical values.

TABLE 2. PIN CHARACTERISTICS

Symbol	Parameter	Test Conditions	Minimum	Typical	Maximum	Units
C _{IN}	Input Capacitance			4		pF
R _{PULLDOWN}	Input Pulldown Resistor			51		KΩ

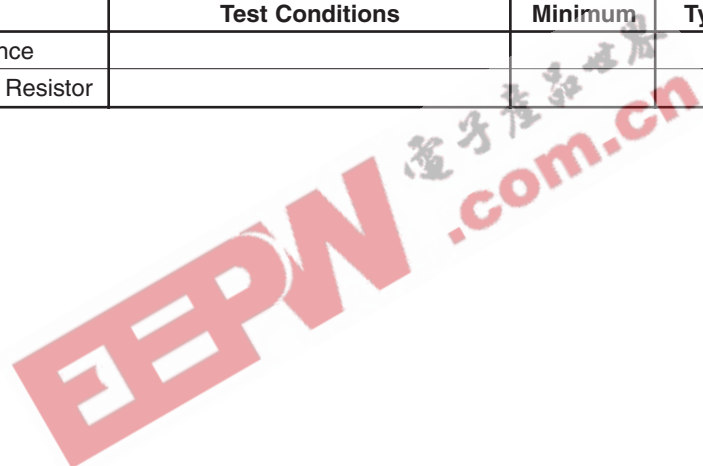



ABSOLUTE MAXIMUM RATINGS

Supply Voltage, V_{CC}	4.6V
Inputs, V_i	-0.5V to $V_{CC} + 0.5V$
Outputs, I_o	
Continuous Current	50mA
Surge Current	100mA
Package Thermal Impedance, θ_{JA}	101.7°C/W (0 mps)
Storage Temperature, T_{STG}	-65°C to 150°C

NOTE: Stresses beyond those listed under Absolute Maximum Ratings may cause permanent damage to the device. These ratings are stress specifications only. Functional operation of product at these conditions or any conditions beyond those listed in the *DC Characteristics* or *AC Characteristics* is not implied. Exposure to absolute maximum rating conditions for extended periods may affect product reliability.

TABLE 3A. POWER SUPPLY DC CHARACTERISTICS, $V_{CC} = 3.3V \pm 5\%$, $T_A = 0^\circ C$ TO $70^\circ C$

Symbol	Parameter	Test Conditions	Minimum	Typical	Maximum	Units
V_{CC}	Core Supply Voltage		3.135	3.3	3.465	V
V_{CCA}	Analog Supply Voltage		3.135	3.3	3.465	V
I_{CC}	Power Supply Current				70	mA
I_{CCA}	Analog Supply Current				15	mA
I_{EE}	Power Supply Current				85	mA

TABLE 3B. LVCMOS/LVTTL DC CHARACTERISTICS, $V_{CC} = 3.3V \pm 5\%$, $T_A = 0^\circ C$ TO $70^\circ C$

Symbol	Parameter	Test Conditions	Minimum	Typical	Maximum	Units
V_{IH}	Input High Voltage	FREQ_SEL	2		$V_{CC} + 0.3$	V
V_{IL}	Input Low Voltage	FREQ_SEL	-0.3		0.8	V
I_{IH}	Input High Current	FREQ_SEL $V_{CC} = V_{IN} = 3.465V$			150	μA
I_{IL}	Input Low Current	FREQ_SEL $V_{CC} = 3.465V, V_{IN} = 0V$	-5			μA

TABLE 3C. LVPECL DC CHARACTERISTICS, $V_{CC} = 3.3V \pm 5\%$, $T_A = 0^\circ C$ TO $70^\circ C$

Symbol	Parameter	Test Conditions	Minimum	Typical	Maximum	Units
V_{OH}	Output High Voltage; NOTE 1		$V_{CC} - 1.4$		$V_{CC} - 0.9$	V
V_{OL}	Output Low Voltage; NOTE 1		$V_{CC} - 2.0$		$V_{CC} - 1.7$	V
V_{SWING}	Peak-to-Peak Output Voltage Swing		0.6		1.0	V

NOTE 1: Outputs terminated with 50Ω to $V_{CC} - 2V$.

TABLE 4. CRYSTAL CHARACTERISTICS

Parameter	Test Conditions	Minimum	Typical	Maximum	Units
Mode of Oscillation		Fundamental			
Frequency		12		40	MHz
Equivalent Series Resistance (ESR)				50	Ω
Shunt Capacitance				7	pF



TABLE 5. AC CHARACTERISTICS, $V_{CC} = 3.3V \pm 5\%$, $T_A = 0^\circ C$ TO $70^\circ C$

Symbol	Parameter	Test Conditions	Minimum	Typical	Maximum	Units
f_{OUT}	Output Frequency			155.52		MHz
				156.25		MHz
				161.13		MHz
$f_{jit}(\emptyset)$	RMS Phase Jitter (Random); NOTE 1	155.52MHz @ Integration Range: 12KHz - 20MHz		0.74		ps
		156.25MHz @ Integration Range: 1.875MHz - 20MHz		0.43		ps
		156.25MHz @ Integration Range: 12KHz - 20MHz		0.75		ps
		161.13MHz @ Integration Range: 1.933MHz - 20MHz		0.43		ps
		161.13MHz @ Integration Range: 12KHz - 20MHz		0.72		ps
t_R / t_F	Output Rise/Fall Time	20% to 80%	325		600	ps
odc	Output Duty Cycle		49		51	%

NOTE 1: Please refer to the Phase Noise Plots following this section.

EEPW.com.cn 电子产品世界



TYPICAL PHASE NOISE AT 155.52MHz

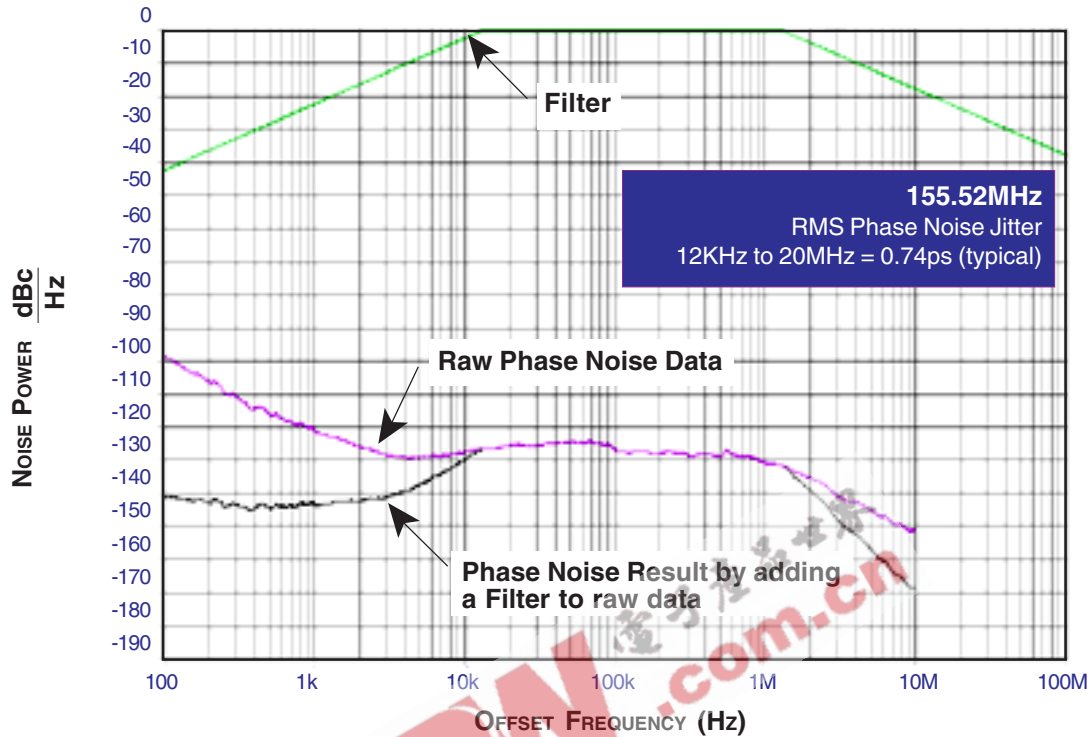

TYPICAL PHASE NOISE AT 156.25MHz

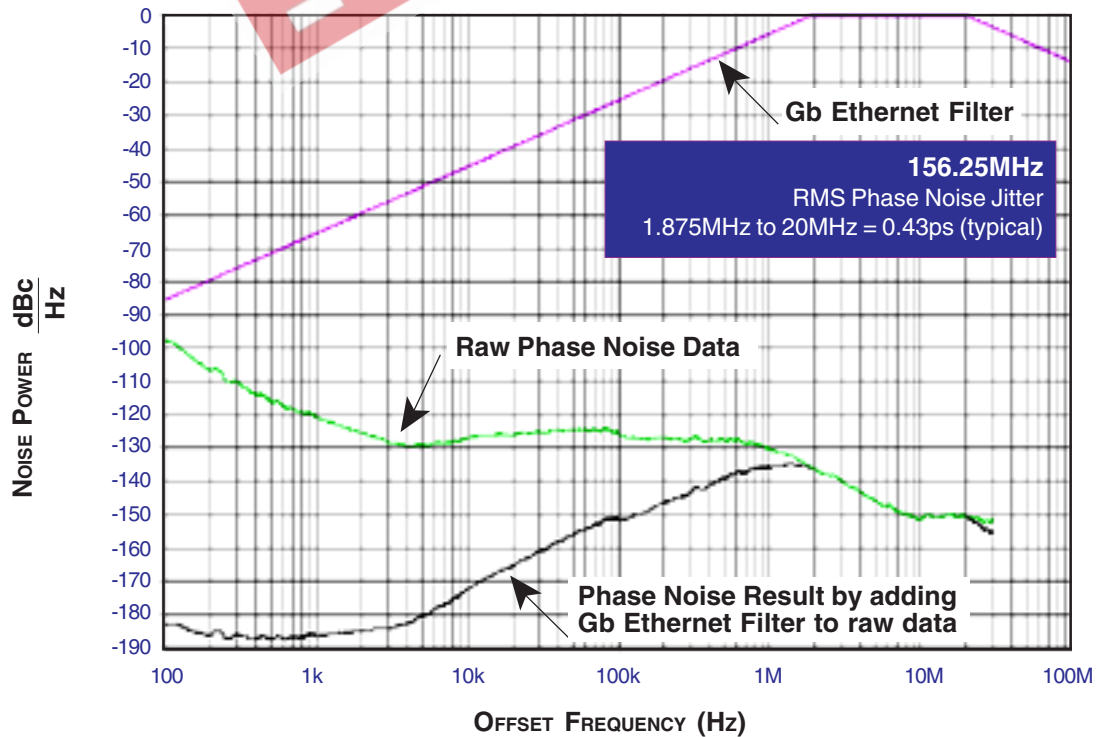



TYPICAL PHASE NOISE AT 161.13MHz

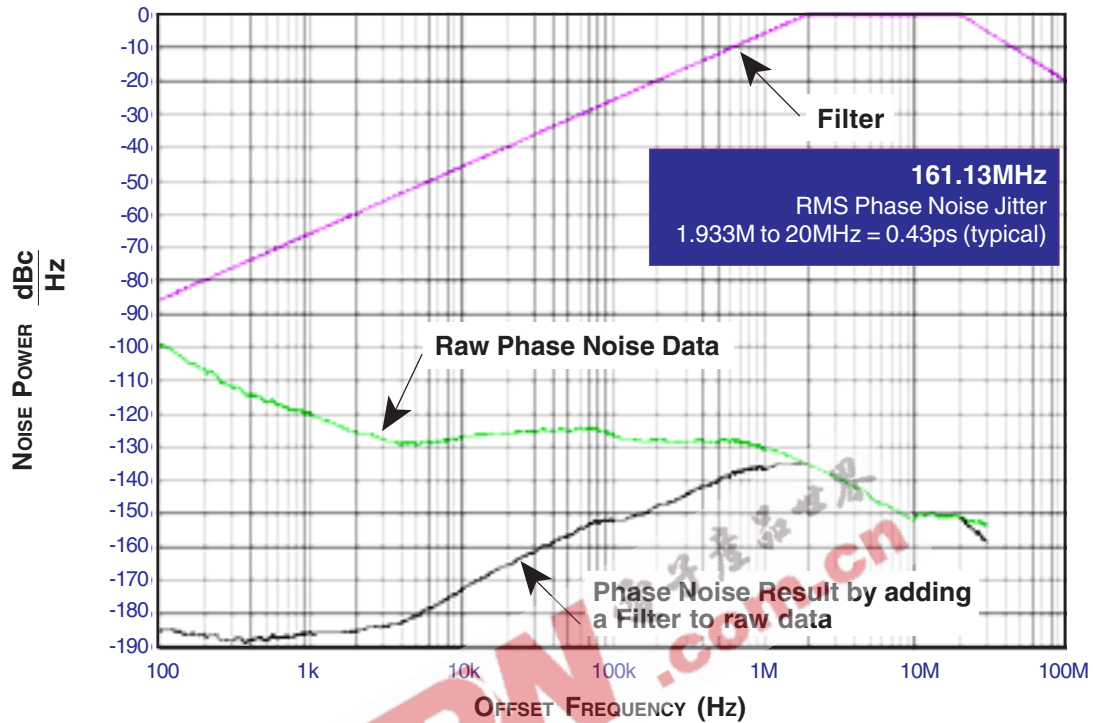



PARAMETER MEASUREMENT INFORMATION

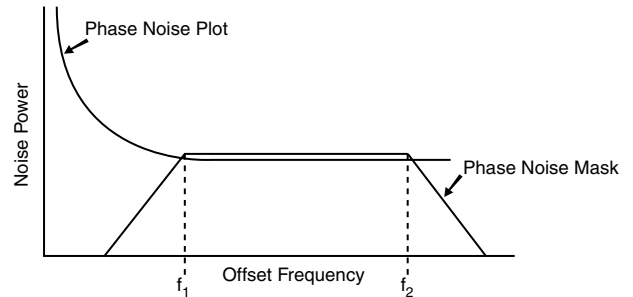
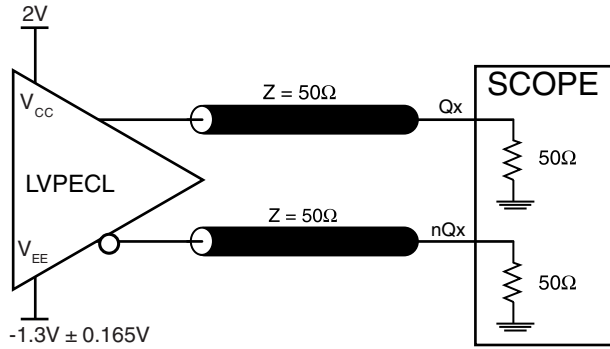

$$\text{RMS Jitter} = \sqrt{\text{Area Under the Masked Phase Noise Plot}}$$

3.3V OUTPUT LOAD AC TEST CIRCUIT

RMS PHASE JITTER

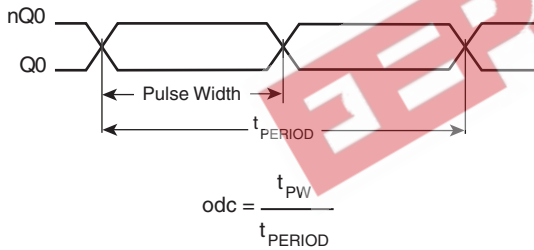

$$\text{odc} = \frac{t_{\text{PW}}}{t_{\text{PERIOD}}}$$

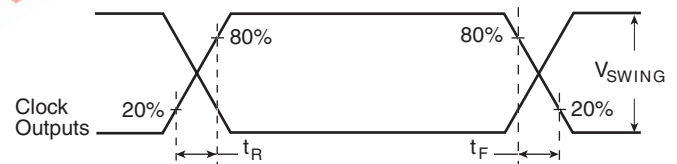

OUTPUT DUTY CYCLE/PULSE WIDTH/PERIOD

OUTPUT RISE/FALL TIME



APPLICATION INFORMATION

POWER SUPPLY FILTERING TECHNIQUES

As in any high speed analog circuitry, the power supply pins are vulnerable to random noise. The ICS843051 provides separate power supplies to isolate any high switching noise from the outputs to the internal PLL. V_{CC} , and V_{CCA} should be individually connected to the power supply plane through vias, and bypass capacitors should be used for each pin. To achieve optimum jitter performance, power supply isolation is required. *Figure 1* illustrates how a 10Ω resistor along with a $10\mu\text{F}$ and a $.01\mu\text{F}$ bypass capacitor should be connected to each V_{CCA} pin.

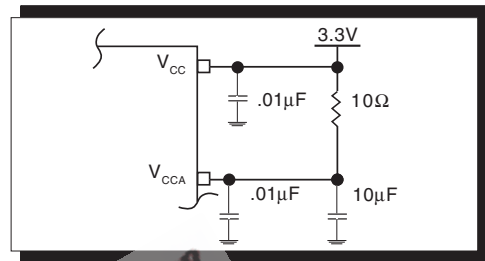

FIGURE 1. POWER SUPPLY FILTERING

CRYSTAL INPUT INTERFACE

The ICS843051 has been characterized with 18pF parallel resonant crystals. The capacitor values, C1 and C2, shown in *Figure 2* below were determined using a 26.04167MHz, 18pF

parallel resonant crystal and were chosen to minimize the ppm error. The optimum C1 and C2 values can be slightly adjusted for different board layouts.

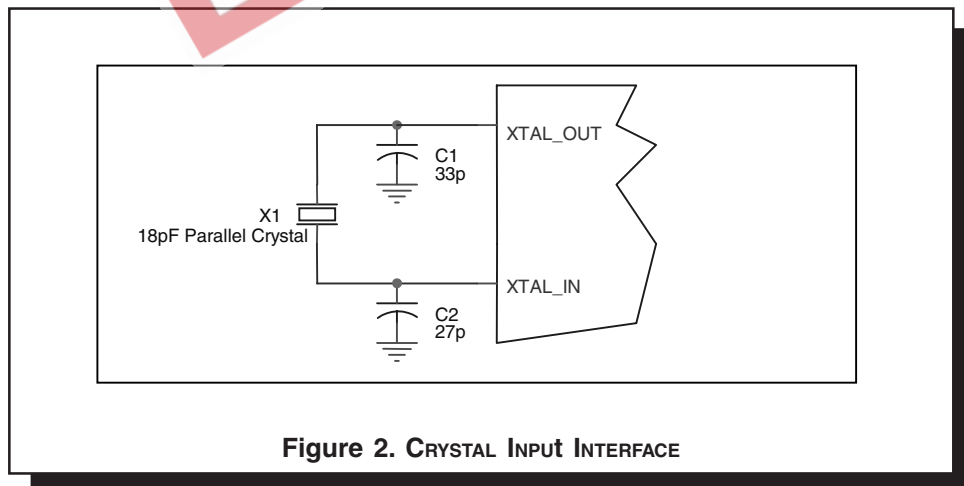

Figure 2. CRYSTAL INPUT INTERFACE



LAYOUT GUIDELINE

Figure 3A shows a schematic example of the ICS843051. An example of LVEPCL termination is shown in this schematic. Additional LVPECL termination approaches are shown in the LVPECL Termination Application Note. In this example, an 18 pF

parallel resonant crystal is used. The C1 = 27pF and C2 = 33pF are recommended for frequency accuracy. The C1 and C2 values may be slightly adjusted for optimizing frequency accuracy.

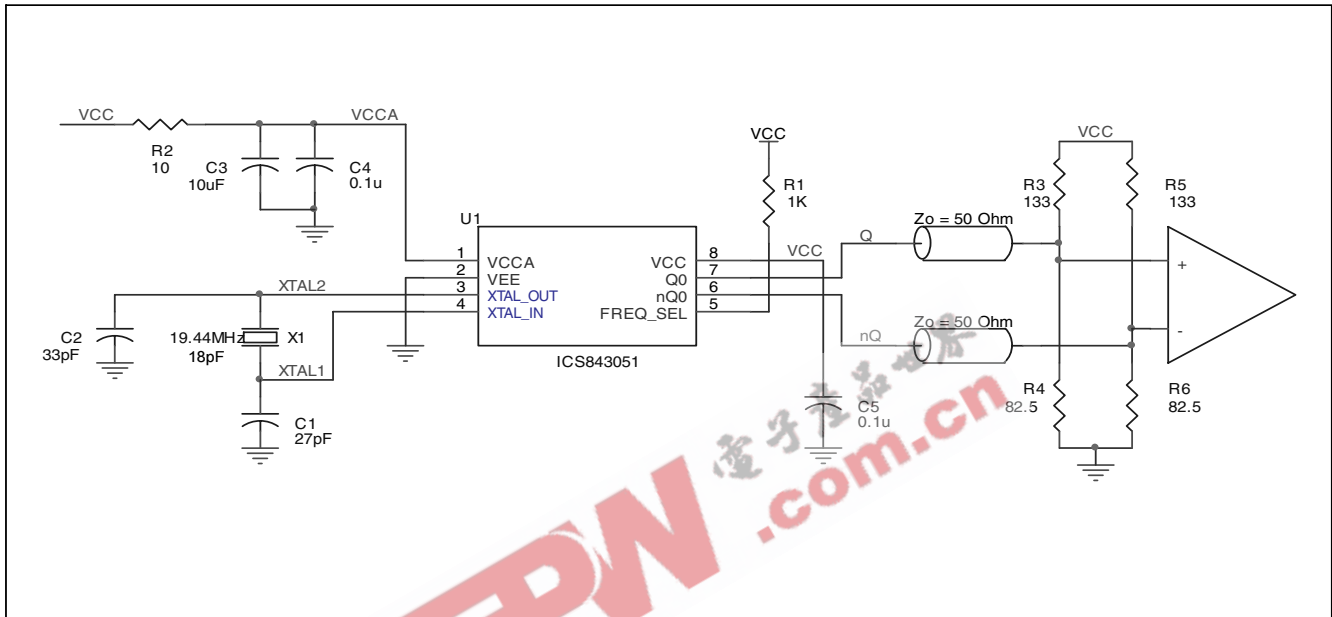

FIGURE 3A. ICS843051 SCHEMATIC EXAMPLE

PC BOARD LAYOUT EXAMPLE

Figure 3B shows an example of ICS843051 P.C. board layout. The crystal X1 footprint shown in this example allows installation of either surface mount HC49S or through-hole HC49 package. The footprints of other components in this example are listed

in the Table 6. There should be at least one decoupling capacitor per power pin. The decoupling capacitors should be located as close as possible to the power pins. The layout assumes that the board has clean analog power ground plane.

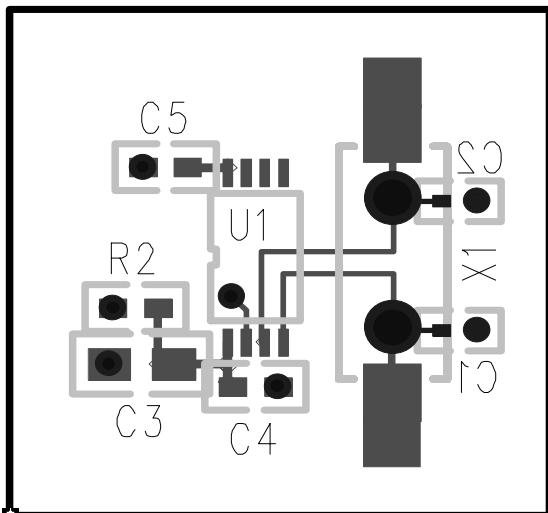

FIGURE 3B. ICS843051 PC BOARD LAYOUT EXAMPLE

TABLE 6. FOOTPRINT TABLE

Reference	Size
C1, C2	0402
C3	0805
C4, C5	0603
R2	0603

NOTE: Table 6, lists component sizes shown in this layout example.



POWER CONSIDERATIONS

This section provides information on power dissipation and junction temperature for the ICS843051. Equations and example calculations are also provided.

1. Power Dissipation.

The total power dissipation for the ICS843051 is the sum of the core power plus the power dissipated in the load(s). The following is the power dissipation for $V_{CC} = 3.3V + 5\% = 3.465V$, which gives worst case results.

NOTE: Please refer to Section 3 for details on calculating power dissipated in the load.

- Power (core)_{MAX} = $V_{CC_MAX} * I_{EE_TYP} = 3.465V * 85mA = 294.5mW$
- Power (outputs)_{MAX} = **30mW/Loaded Output pair**

$$\text{Total Power}_{MAX} (3.465V, \text{ with all outputs switching}) = 294.5mW + 30mW = \mathbf{324.5mW}$$

2. Junction Temperature.

Junction temperature, T_j , is the temperature at the junction of the bond wire and bond pad and directly affects the reliability of the device. The maximum recommended junction temperature for HiPerClockS™ devices is 125°C.

The equation for T_j is as follows: $T_j = \theta_{JA} * Pd_total + T_A$

T_j = Junction Temperature

θ_{JA} = Junction-to-Ambient Thermal Resistance

Pd_total = Total Device Power Dissipation (example calculation is in section 1 above)

T_A = Ambient Temperature

In order to calculate junction temperature, the appropriate junction-to-ambient thermal resistance θ_{JA} must be used. Assuming a moderate air flow of 1 meter per second and a multi-layer board, the appropriate value is 90.5°C/W per Table 7 below.

Therefore, T_j for an ambient temperature of 70°C with all outputs switching is:

$$70^\circ C + 0.324W * 90.5^\circ C/W = 99.3^\circ C. \text{ This is well below the limit of } 125^\circ C.$$

This calculation is only an example. T_j will obviously vary depending on the number of loaded outputs, supply voltage, air flow, and the type of board (single layer or multi-layer).

TABLE 7. THERMAL RESISTANCE θ_{JA} FOR 8-PIN TSSOP, FORCED CONVECTION

θ_{JA} by Velocity (Meters per Second)			
	0	1	2.5
Multi-Layer PCB, JEDEC Standard Test Boards	101.7°C/W	90.5°C/W	89.8°C/W



3. Calculations and Equations.

The purpose of this section is to derive the power dissipated into the load.

LVPECL output driver circuit and termination are shown in *Figure 4*.

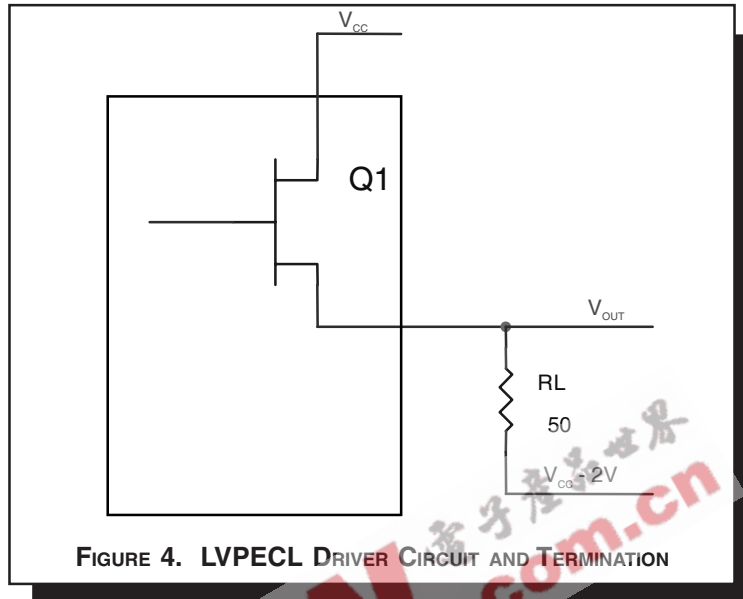

FIGURE 4. LVPECL DRIVER CIRCUIT AND TERMINATION

To calculate worst case power dissipation into the load, use the following equations which assume a 50Ω load, and a termination voltage of $V_{CC} - 2V$.

- For logic high, $V_{OUT} = V_{OH_MAX} = V_{CC_MAX} - 0.9V$

$$(V_{CC_MAX} - V_{OH_MAX}) = 0.9V$$

- For logic low, $V_{OUT} = V_{OL_MAX} = V_{CC_MAX} - 1.7V$

$$(V_{CC_MAX} - V_{OL_MAX}) = 1.7V$$

Pd_H is power dissipation when the output drives high.

Pd_L is the power dissipation when the output drives low.

$$Pd_H = [(V_{OH_MAX} - (V_{CC_MAX} - 2V))/R_L] * (V_{CC_MAX} - V_{OH_MAX}) = [(2V - (V_{CC_MAX} - V_{OH_MAX}))/R_L] * (V_{CC_MAX} - V_{OH_MAX}) = [(2V - 0.9V)/50\Omega] * 0.9V = 19.8mW$$

$$Pd_L = [(V_{OL_MAX} - (V_{CC_MAX} - 2V))/R_L] * (V_{CC_MAX} - V_{OL_MAX}) = [(2V - (V_{CC_MAX} - V_{OL_MAX}))/R_L] * (V_{CC_MAX} - V_{OL_MAX}) = [(2V - 1.7V)/50\Omega] * 1.7V = 10.2mW$$

Total Power Dissipation per output pair = $Pd_H + Pd_L = 30mW$



RELIABILITY INFORMATION

TABLE 8. θ_{JA} VS. AIR FLOW TABLE FOR 8 LEAD TSSOP

θ_{JA} by Velocity (Meters per Second)			
	0	1	2.5
Multi-Layer PCB, JEDEC Standard Test Boards	101.7°C/W	90.5°C/W	89.8°C/W

TRANSISTOR COUNT

The transistor count for ICS843051 is: 1892

EEPW 电子产品世界
.com.cn



PACKAGE OUTLINE - G SUFFIX FOR 8 LEAD TSSOP

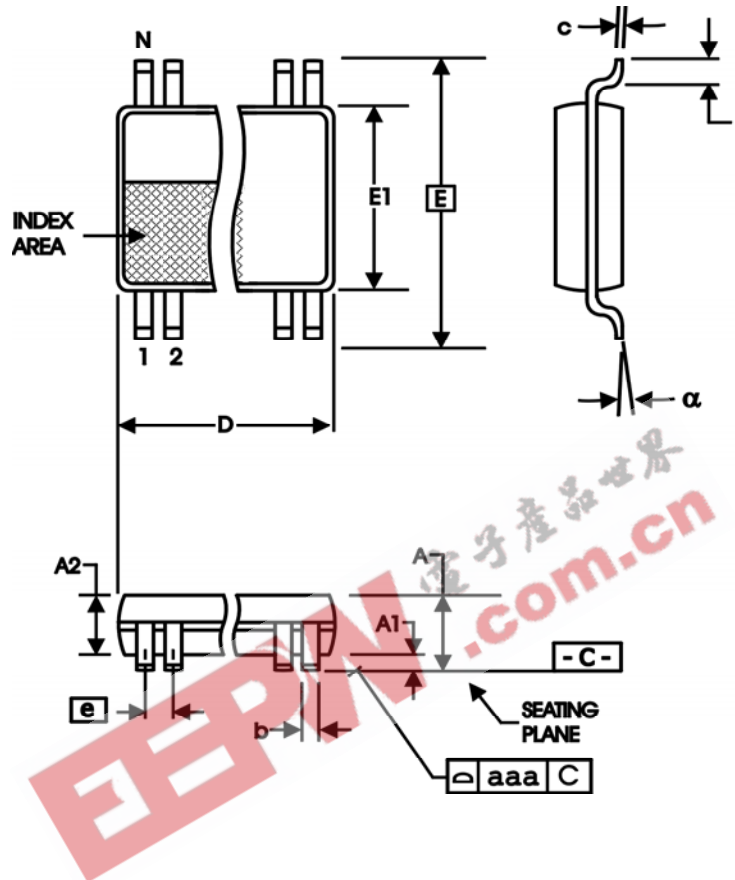

TABLE 9. PACKAGE DIMENSIONS

SYMBOL	Millimeters	
	Minimum	Maximum
N	8	
A	--	1.20
A1	0.05	0.15
A2	0.80	1.05
b	0.19	0.30
c	0.09	0.20
D	2.90	3.10
E	6.40 BASIC	
E1	4.30	4.50
e	0.65 BASIC	
L	0.45	0.75
alpha	0°	8°
aaa	--	0.10

Reference Document: JEDEC Publication 95, MO-153



Integrated
Circuit
Systems, Inc.

ICS843051

FEMTOCLOCKS™ CRYSTAL-TO- 3.3V LVPECL CLOCK GENERATOR

TABLE 10. ORDERING INFORMATION

Part/Order Number	Marking	Package	Count	Temperature
ICS843051AG	3051A	8 Lead TSSOP	100 per tube	0°C to 70°C
ICS843051AGT	3051A	8 Lead TSSOP on Tape and Reel	2500	0°C to 70°C
ICS843051AGLF	051AL	8 Lead "Lead-Free" TSSOP	100 per tube	0°C to 70°C
ICS843051AGLFT	051AL	8 Lead "Lead-Free" TSSOP on Tape and Reel	2500	0°C to 70°C

EEPW 电子产品世界
.com.cn

The aforementioned trademarks, HiPerClockS™ and FemtoClocks™ are a trademark of Integrated Circuit Systems, Inc. or its subsidiaries in the United States and/or other countries. While the information presented herein has been checked for both accuracy and reliability, Integrated Circuit Systems, Incorporated (ICS) assumes no responsibility for either its use or for infringement of any patents or other rights of third parties, which would result from its use. No other circuits, patents, or licenses are implied. This product is intended for use in normal commercial applications. Any other applications such as those requiring extended temperature range, high reliability, or other extraordinary environmental requirements are not recommended without additional processing by ICS. ICS reserves the right to change any circuitry or specifications without notice. ICS does not authorize or warrant any ICS product for use in life support devices or critical medical instruments.



Integrated
Circuit
Systems, Inc.

ICS843051

FEMTOCLOCKS™ CRYSTAL-TO- 3.3V LVPECL CLOCK GENERATOR

REVISION HISTORY SHEET

Rev	Table	Page	Description of Change	Date
A	T10	14	Ordering Information Table - corrected count from 154 per tube to 100 per tube.	11/16/04
A	T10	14	Added Lead-Free bullet in Features section. Ordering Information Table - added "Lead-Free" part.	12/14/04

EEPW 电子产品世界
.com.cn