



Integrated  
Circuit  
Systems, Inc.

# ICS84329B

## 700MHz, Low JITTER, CRYSTAL-TO-3.3V DIFFERENTIAL LVPECL FREQUENCY SYNTHESIZER

### GENERAL DESCRIPTION

The ICS84329B is a general purpose, single output high frequency synthesizer and a member of the HiPerClockS™ family of High Performance Clock Solutions from ICS. The VCO operates at a frequency range of 250MHz to 700MHz. The VCO frequency is programmed in steps equal to the value of the crystal frequency divided by 16. The VCO and output frequency can be programmed using the serial or parallel interfaces to the configuration logic. The output can be configured to divide the VCO frequency by 1, 2, 4, and 8. Output frequency steps as small as 125kHz to 1MHz can be achieved using a 16MHz crystal depending on the output dividers.

### FEATURES

- Fully integrated PLL, no external loop filter requirements
- One differential 3.3V LVPECL output
- Parallel resonant crystal oscillator interface
- Output frequency range: 31.25MHz to 700MHz
- VCO range: 250MHz to 700MHz
- Parallel interface for programming counter and output dividers during power-up
- Serial 3 wire interface
- RMS Period jitter: 5.5ps (maximum)
- Cycle-to-cycle jitter: 35ps (maximum)
- 3.3V supply voltage
- 0°C to 70°C ambient operating temperature
- Available in both standard and lead-free RoHS compliant packages

### BLOCK DIAGRAM

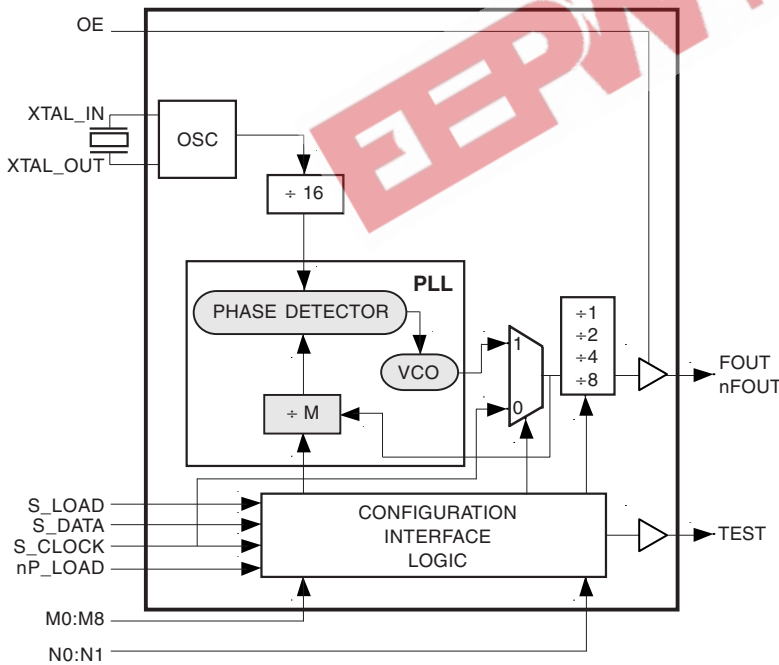

### PIN ASSIGNMENT

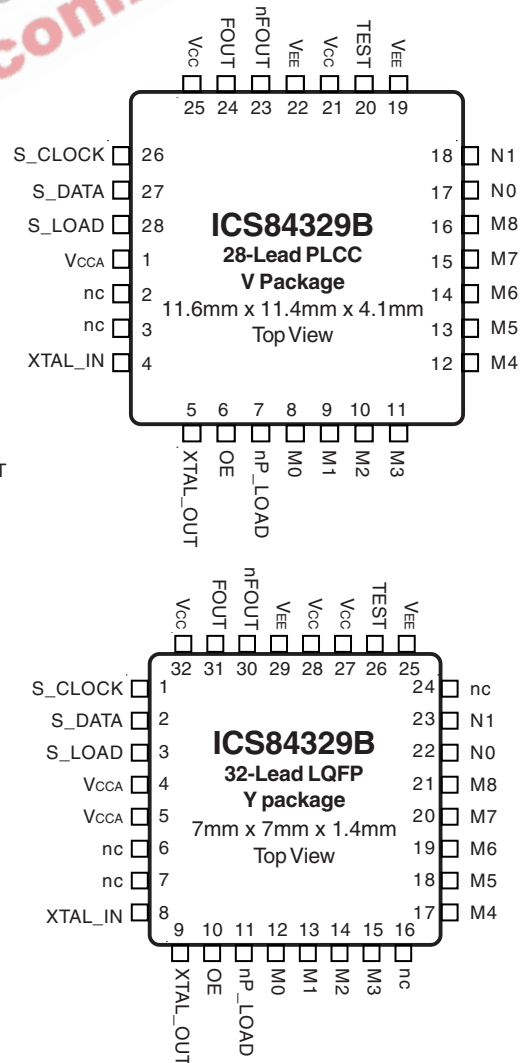



### FUNCTIONAL DESCRIPTION

*NOTE: The functional description that follows describes operation using a 16MHz crystal. Valid PLL loop divider values for different crystal or input frequencies are defined in the Input Frequency Characteristics, Table 6, NOTE 1.*

The ICS84329B features a fully integrated PLL and therefore requires no external components for setting the loop bandwidth. A series-resonant, fundamental crystal is used as the input to the on-chip oscillator. The output of the oscillator is divided by 16 prior to the phase detector. With a 16MHz crystal this provides a 1MHz reference frequency. The VCO of the PLL operates over a range of 250MHz to 700MHz. The output of the M divider is also applied to the phase detector.

The phase detector and the M divider force the VCO output frequency to be M times the reference frequency by adjusting the VCO control voltage. Note that for some values of M (either too high or too low), the PLL will not achieve lock. The output of the VCO is scaled by a divider prior to being sent to each of the LVPECL output buffers. The divider provides a 50% output duty cycle.

The programmable features of the ICS84329B support two input modes to program the M divider and N output divider. The two input operational modes are parallel and serial. Figure 1 shows the timing diagram for each mode. In parallel mode the nP\_LOAD input is LOW. The data on inputs M0 through M8 and N0 through N1 is passed directly to the M divider and

N output divider. On the LOW-to-HIGH transition of the nP\_LOAD input, the data is latched and the M divider remains loaded until the next LOW transition on nP\_LOAD or until a serial event occurs. The TEST output is Mode 000 (shift register out) when operating in the parallel input mode. The relationship between the VCO frequency, the crystal frequency and the M divider is defined as follows:  $f_{VCO} = \frac{f_{xtal}}{16} \times M$

The M value and the required values of M0 through M8 are shown in Table 3B, Programmable VCO Frequency Function Table. Valid M values for which the PLL will achieve lock are defined as  $250 \leq M \leq 511$ . The frequency out is defined as follows:  $f_{out} = \frac{f_{VCO}}{N} = \frac{f_{xtal}}{16} \times \frac{M}{N}$

Serial operation occurs when nP\_LOAD is HIGH and S\_LOAD is LOW. The shift register is loaded by sampling the S\_DATA bits with the rising edge of S\_CLOCK. The contents of the shift register are loaded into the M divider when S\_LOAD transitions from LOW-to-HIGH. The M divide and N output divide values are latched on the HIGH-to-LOW transition of S\_LOAD. If S\_LOAD is held HIGH, data at the S\_DATA input is passed directly to the M divider on each rising edge of S\_CLOCK. The serial mode can be used to program the M and N bits and test bits T2:T0. The internal registers T2:T0 determine the state of the TEST output as follows:

T2	T1	T0	TEST Output	fOUT
0	0	0	Shift Register Out	fOUT
0	0	1	High	fOUT
0	1	0	PLL Reference Xtal ÷ 16	fOUT
0	1	1	VCO ÷ M (non 50% Duty M divider)	fOUT
1	0	0	fOUT LVCMOS Output Frequency < 200MHz	fOUT
1	0	1	Low	fOUT
1	1	0	S_CLOCK ÷ M (non 50% Duty Cycle M divider)	S_CLOCK ÷ N divider
1	1	1	fOUT ÷ 4	fOUT

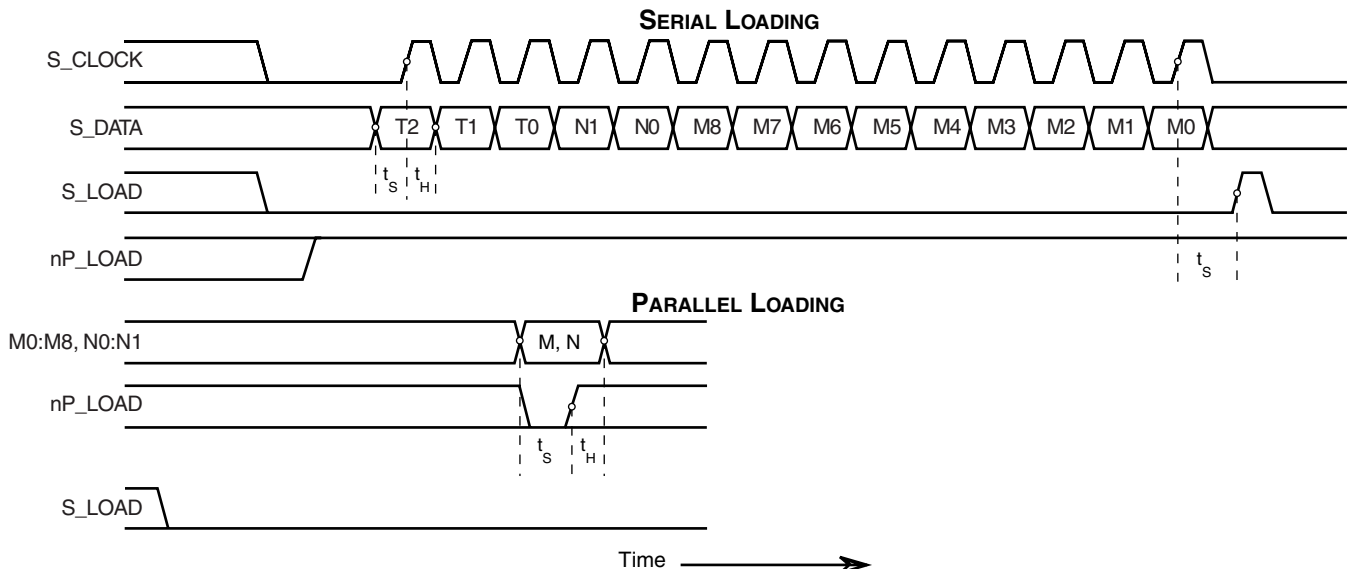

FIGURE 1. PARALLEL & SERIAL LOAD OPERATIONS



**TABLE 1. PIN DESCRIPTIONS**

Name	Type		Description
$V_{CCA}$	Power		Analog supply pin.
XTAL_IN, XTAL_OUT	Input		Crystal oscillator interface. XTAL_IN is the input. XTAL_OUT is the output.
OE	Input	Pullup	Output enable. When logic HIGH, the outputs are enabled (default). When logic LOW, the outputs are disabled and drive differential low: FOUT = LOW, nFOUT = HIGH. LVCMOS / LVTTTL interface levels.
nP_LOAD	Input	Pullup	Parallel load input. Determines when data present at M8:M0 is loaded into M divider, and when data present at N1:N0 sets the N output divide value. LVCMOS / LVTTTL interface levels.
M0, M1, M2, M3, M4, M5, M6, M7, M8	Input	Pullup	M divider inputs. Data latched on LOW-to-HIGH transition of nP_LOAD input. LVCMOS / LVTTTL interface levels.
N0, N1	Input	Pullup	Determines N output divider value as defined in Table 3C Function Table. LVCMOS / LVTTTL interface levels.
$V_{EE}$	Power		Negative supply pins.
TEST	Output		Test output which is used in the serial mode of operation. LVCMOS / LVTTTL interface levels.
$V_{CC}$	Power		Core supply pins.
nFOUT, FOUT	Output		Differential output for the synthesizer. 3.3V LVPECL interface levels.
S_CLOCK	Input	Pulldown	Clocks the serial data present at S_DATA input into the shift register on the rising edge of S_CLOCK. LVCMOS / LVTTTL interface levels.
S_DATA	Input	Pulldown	Shift register serial input. Data sampled on the rising edge of S_CLOCK. LVCMOS / LVTTTL interface levels.
S_LOAD	Input	Pulldown	Controls transition of data from shift register into the M divider. LVCMOS / LVTTTL interface levels.

NOTE: *Pullup* and *Pulldown* refer to internal input resistors. See Table 2, Pin Characteristics, for typical values.

**TABLE 2. PIN CHARACTERISTICS**

Symbol	Parameter	Test Conditions	Minimum	Typical	Maximum	Units
$C_{IN}$	Input Capacitance			4		pF
$R_{PULLUP}$	Input Pullup Resistor			51		k $\Omega$
$R_{PULLDOWN}$	Input Pulldown Resistor			51		k $\Omega$



Integrated  
Circuit  
Systems, Inc.

# ICS84329B

## 700MHz, Low JITTER, CRYSTAL-TO-3.3V DIFFERENTIAL LVPECL FREQUENCY SYNTHESIZER

**TABLE 3A. PARALLEL AND SERIAL MODE FUNCTION TABLE**

Inputs						Conditions
nP_LOAD	M	N	S_LOAD	S_CLOCK	S_DATA	
X	X	X	X	X	X	Reset. M and N bits are all set HIGH.
L	Data	Data	X	X	X	Data on M and N inputs passed directly to M divider and N output divider. TEST mode 000.
↑	Data	Data	L	X	X	Data is latched into input registers and remains loaded until next LOW transition or until a serial event occurs.
H	X	X	L	↑	Data	Serial input mode. Shift register is loaded with data on S_DATA on each rising edge of S_CLOCK.
H	X	X	↑	L	Data	Contents of the shift register are passed to the M divider and N output divider.
H	X	X	↓	L	Data	M divide and N output divide values are latched.
H	X	X	L	X	X	Parallel or serial input do not affect shift registers.

NOTE: L = LOW  
H = HIGH  
X = Don't care  
↑ = Rising edge transition  
↓ = Falling edge transition

**TABLE 3B. PROGRAMMABLE VCO FREQUENCY FUNCTION TABLE**

VCO Frequency (MHz)	M Divide	256	128	64	32	16	8	4	2	1
		M8	M7	M6	M5	M4	M3	M2	M1	M0
250	250	0	1	1	1	1	1	0	1	0
251	251	0	1	1	1	1	1	0	1	1
252	252	0	1	1	1	1	1	1	0	0
253	253	0	1	1	1	1	1	1	0	1
•	•	•	•	•	•	•	•	•	•	•
•	•	•	•	•	•	•	•	•	•	•
509	509	1	1	1	1	1	1	1	0	1
510	510	1	1	1	1	1	1	1	1	0
511	511	1	1	1	1	1	1	1	1	1

NOTE 1: These M divide values and the resulting frequencies correspond to a crystal frequency of 16MHz.

**TABLE 3C. PROGRAMMABLE OUTPUT DIVIDER FUNCTION TABLE**

Inputs		N Divider Value	Output Frequency (MHz)	
N1	N0		Minimum	Maximum
0	0	1	250	700
0	1	2	125	350
1	0	4	62.5	175
1	1	8	31.25	87.5



# ICS84329B

## 700MHz, Low JITTER, CRYSTAL-TO-3.3V DIFFERENTIAL LVPECL FREQUENCY SYNTHESIZER

### ABSOLUTE MAXIMUM RATINGS

Supply Voltage, $V_{CC}$	4.6V
Inputs, $V_I$	-0.5V to $V_{CC} + 0.5V$
Outputs, $I_O$	
Continuous Current	50mA
Surge Current	100mA
Package Thermal Impedance, $\theta_{JA}$	37.8°C/W (0 lfpm)
Storage Temperature, $T_{STG}$	-65°C to 150°C

NOTE: Stresses beyond those listed under Absolute Maximum Ratings may cause permanent damage to the device. These ratings are stress specifications only. Functional operation of product at these conditions or any conditions beyond those listed in the *DC Characteristics* or *AC Characteristics* is not implied. Exposure to absolute maximum rating conditions for extended periods may affect product reliability.

TABLE 4A. POWER SUPPLY DC CHARACTERISTICS,  $V_{CC} = V_{CCA} = 3.3V \pm 5\%$ ,  $T_A = 0^\circ C$  TO  $70^\circ C$

Symbol	Parameter	Test Conditions	Minimum	Typical	Maximum	Units
$V_{CC}$	Core Supply Voltage		3.135	3.3	3.465	V
$V_{CCA}$	Analog Supply Voltage		3.135	3.3	3.465	V
$I_{CC}$	Power Supply Current				125	mA
$I_{CCA}$	Analog Supply Current				15	mA

TABLE 4B. LVCMOS / LVTTTL DC CHARACTERISTICS,  $V_{CC} = V_{CCA} = 3.3V \pm 5\%$ ,  $T_A = 0^\circ C$  TO  $70^\circ C$

Symbol	Parameter	Test Conditions	Minimum	Typical	Maximum	Units
$V_{IH}$	Input High Voltage		2		$V_{CC} + 0.3$	V
$V_{IL}$	Input Low Voltage		-0.3		0.8	V
$I_{IH}$	Input High Current	M0-M8, N0, N1, OE, nP_LOAD	$V_{CC} = V_{IN} = 3.465V$		5	$\mu A$
		S_LOAD, S_DATA, S_CLOCK	$V_{CC} = V_{IN} = 3.465V$		150	$\mu A$
$I_{IL}$	Input Low Current	M0-M8, N0, N1, OE, nP_LOAD	$V_{CC} = 3.465V, V_{IN} = 0V$	-150		$\mu A$
		S_LOAD, S_DATA, S_CLOCK	$V_{CC} = 3.465V, V_{IN} = 0V$	-5		$\mu A$
$V_{OH}$	Output High Voltage; NOTE 1		2.6			V
$V_{OL}$	Output Low Voltage; NOTE 1				0.5	V

NOTE 1: Outputs terminated with  $50\Omega$  to  $V_{CC}/2$ . See Parameter Measurement Information, 3.3V Output Load Test Circuit.

TABLE 4C. LVPECL DC CHARACTERISTICS,  $V_{CC} = V_{CCA} = 3.3V \pm 5\%$ ,  $T_A = 0^\circ C$  TO  $70^\circ C$

Symbol	Parameter	Test Conditions	Minimum	Typical	Maximum	Units
$V_{OH}$	Output High Voltage; NOTE 1		$V_{CC} - 1.4$		$V_{CC} - 0.9$	V
$V_{OL}$	Output Low Voltage; NOTE 1		$V_{CC} - 2.0$		$V_{CC} - 1.7$	V
$V_{SWING}$	Peak-to-Peak Output Voltage Swing		0.6		1.0	V

NOTE 1: Outputs terminated with  $50\Omega$  to  $V_{CC} - 2V$ .



**TABLE 5. CRYSTAL CHARACTERISTICS**

Parameter	Test Conditions	Minimum	Typical	Maximum	Units
Mode of Oscillation		Fundamental			
Frequency		10		25	MHz
Equivalent Series Resistance (ESR)				50	$\Omega$
Shunt Capacitance				7	pF
Drive Level				1	mW

**TABLE 6. INPUT FREQUENCY CHARACTERISTICS,  $V_{CC} = V_{CCA} = 3.3V \pm 5\%$ ,  $T_A = 0^\circ C$  TO  $70^\circ C$**

Symbol	Parameter	Test Conditions	Minimum	Typical	Maximum	Units
$f_{IN}$	Input Frequency	XTAL; NOTE 1	10		25	MHz
		S_CLOCK			50	MHz

NOTE 1: For the crystal frequency range the M value must be set to achieve the minimum or maximum VCO frequency range of 250MHz or 700MHz. Using the minimum frequency of 10MHz valid values of M are  $400 \leq M \leq 511$ . Using the maximum frequency of 25MHz valid values of M are  $160 \leq M \leq 448$ .

**TABLE 7. AC CHARACTERISTICS,  $V_{CC} = V_{CCA} = 3.3V \pm 5\%$ ,  $T_A = 0^\circ C$  TO  $70^\circ C$**

Symbol	Parameter	Test Conditions	Minimum	Typical	Maximum	Units
$F_{OUT}$	Output Frequency				700	MHz
$f_{jit(per)}$	Period Jitter, RMS; NOTE 1, 2	$f_{OUT} \geq 65MHz$			5.5	ps
		$f_{OUT} < 65MHz$			12	ps
$f_{jit(cc)}$	Cycle-to-Cycle Jitter; NOTE 1, 2	$f_{OUT} \geq 50MHz$			35	ps
		$f_{OUT} < 50MHz$			50	ps
$t_R / t_F$	Output Rise/Fall Time	20% to 80%	300		800	ps
$t_S$	Setup Time		5			ns
$t_H$	Hold Time		5			ns
$t_L$	PLL Lock Time				10	ms
odc	Output Duty Cycle		45	50	55	%

See Parameter Measurement Information section.

Characterized using a 16MHz XTAL.

NOTE 1: This parameter is defined in accordance with JEDEC Standard 65

NOTE 2: See Applications section.



Integrated  
Circuit  
Systems, Inc.

# ICS84329B

## 700MHz, Low JITTER, CRYSTAL-TO-3.3V DIFFERENTIAL LVPECL FREQUENCY SYNTHESIZER

### PARAMETER MEASUREMENT INFORMATION

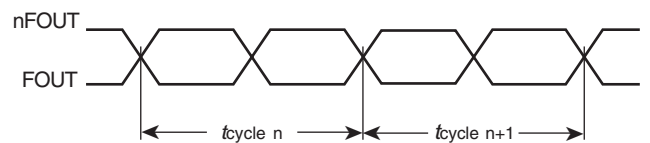
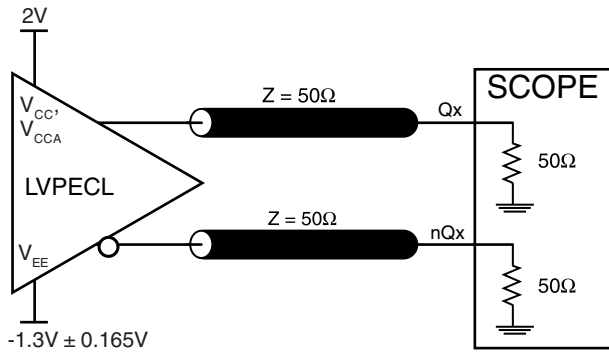

$$t_{jit(cc)} = \frac{t_{cycle\ n} - t_{cycle\ n+1}}{1000\ \text{Cycles}}$$

#### 3.3V OUTPUT LOAD AC TEST CIRCUIT

#### CYCLE-TO-CYCLE JITTER

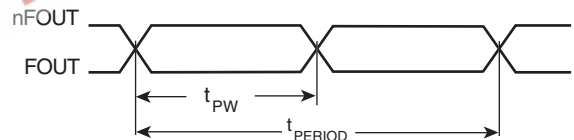
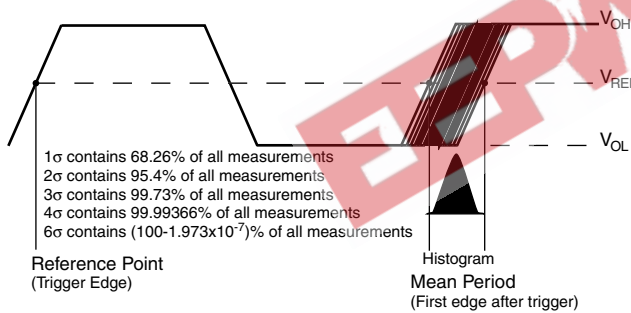

$$odc = \frac{t_{PW}}{t_{PERIOD}} \times 100\%$$

#### PERIOD JITTER

#### OUTPUT DUTY CYCLE/PULSE WIDTH/PERIOD

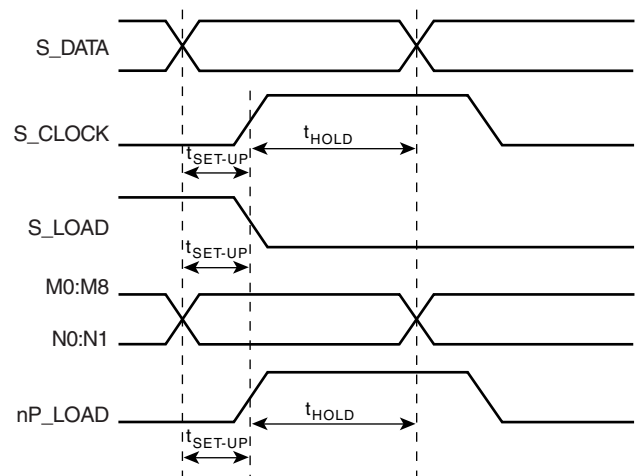
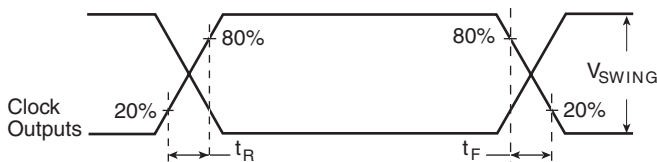

#### OUTPUT RISE/FALL TIME

#### SETUP AND HOLD



## APPLICATION INFORMATION

### POWER SUPPLY FILTERING TECHNIQUES

As in any high speed analog circuitry, the power supply pins are vulnerable to random noise. The ICS84329B provides separate power supplies to isolate any high switching noise from the outputs to the internal PLL.  $V_{CC}$  and  $V_{CCA}$  should be individually connected to the power supply plane through vias, and bypass capacitors should be used for each pin. To achieve optimum jitter performance, power supply isolation is required. *Figure 2* illustrates how a 10Ω resistor along with a 10μF and a .01μF bypass capacitor should be connected to each  $V_{CCA}$  pin. The 10Ω resistor can also be replaced by a ferrite bead.

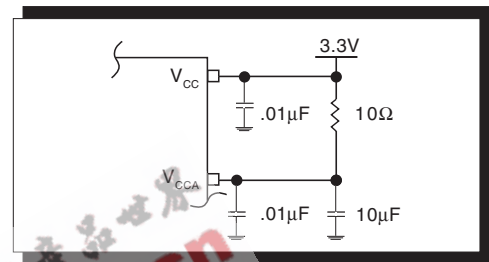

FIGURE 2. POWER SUPPLY FILTERING

### CRYSTAL INPUT INTERFACE

The ICS84329B has been characterized with 18pF parallel resonant crystals. The capacitor values, C1 and C2, shown in *Figure 3* below were determined using a 25MHz, 18pF

parallel resonant crystal and were chosen to minimize the ppm error. The optimum C1 and C2 values can be slightly adjusted for different board layouts.

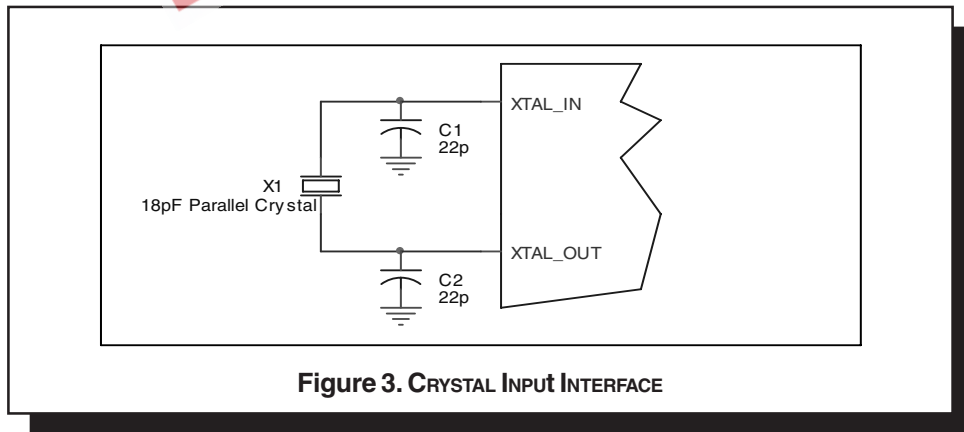

Figure 3. CRYSTAL INPUT INTERFACE

### RECOMMENDATIONS FOR UNUSED INPUT PINS

#### INPUTS:

#### LVC MOS CONTROL PINS:

All control pins have internal pull-ups or pull-downs; additional resistance is not required but can be added for additional protection. A 1kΩ resistor can be used.





Integrated  
Circuit  
Systems, Inc.

# ICS84329B

700MHz, Low JITTER, CRYSTAL-TO-3.3V  
DIFFERENTIAL LVPECL FREQUENCY SYNTHESIZER

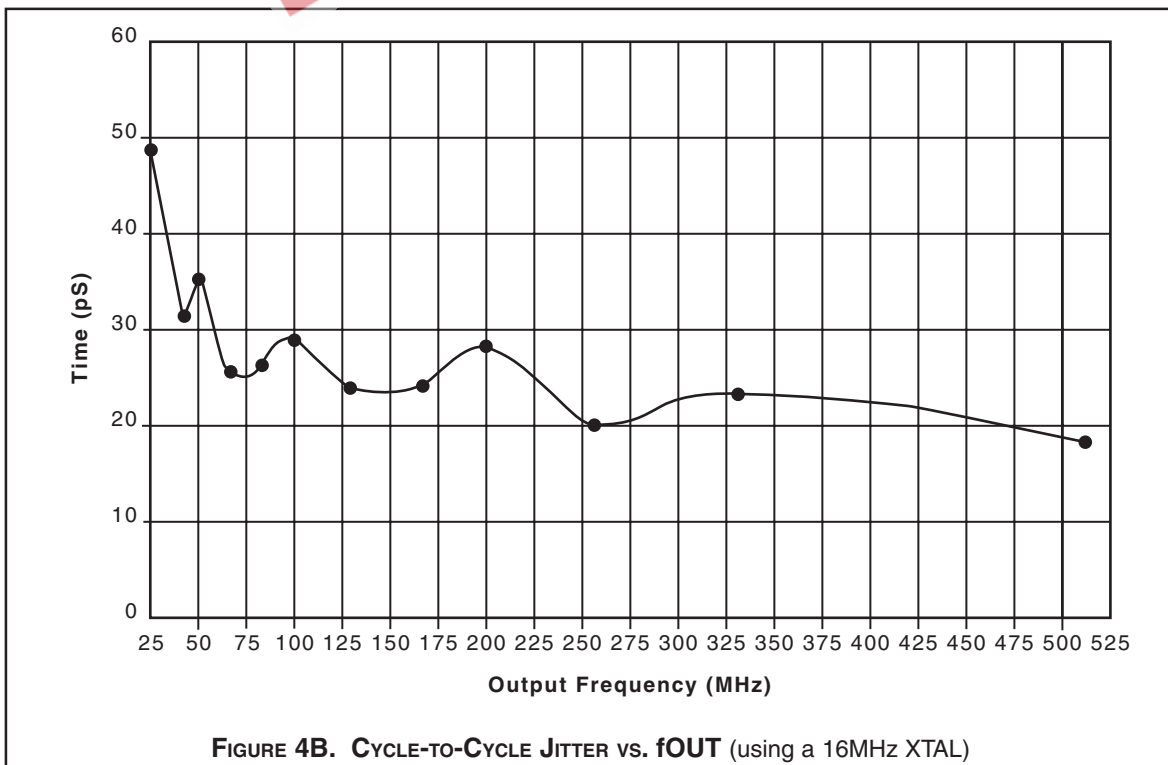
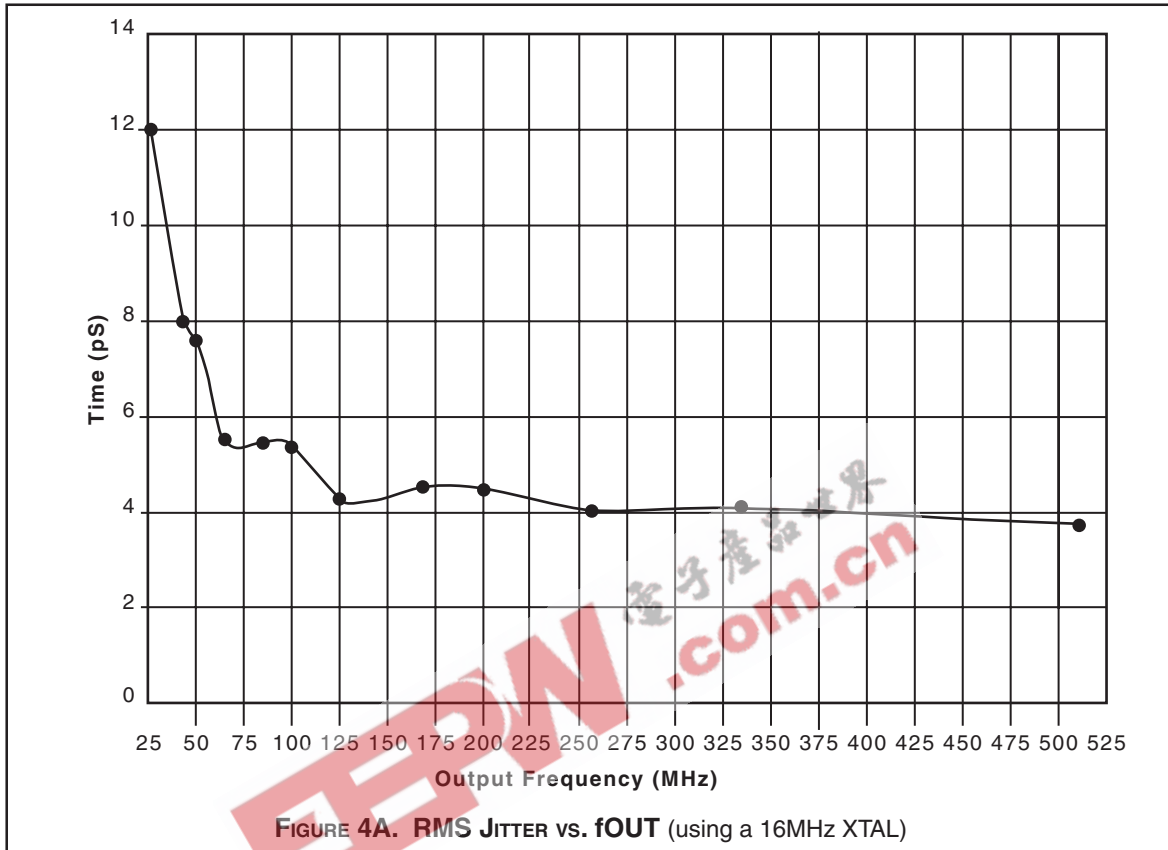



### LAYOUT GUIDELINE

The schematic of the ICS84329B layout example used in this layout guideline is shown in *Figure 5A*. The ICS84329B recommended PCB board layout for this example is shown in *Figure 5B*. This layout example is used as a general guideline. The

layout in the actual system will depend on the selected component types, the density of the components, the density of the traces, and the stack up of the P.C. board.

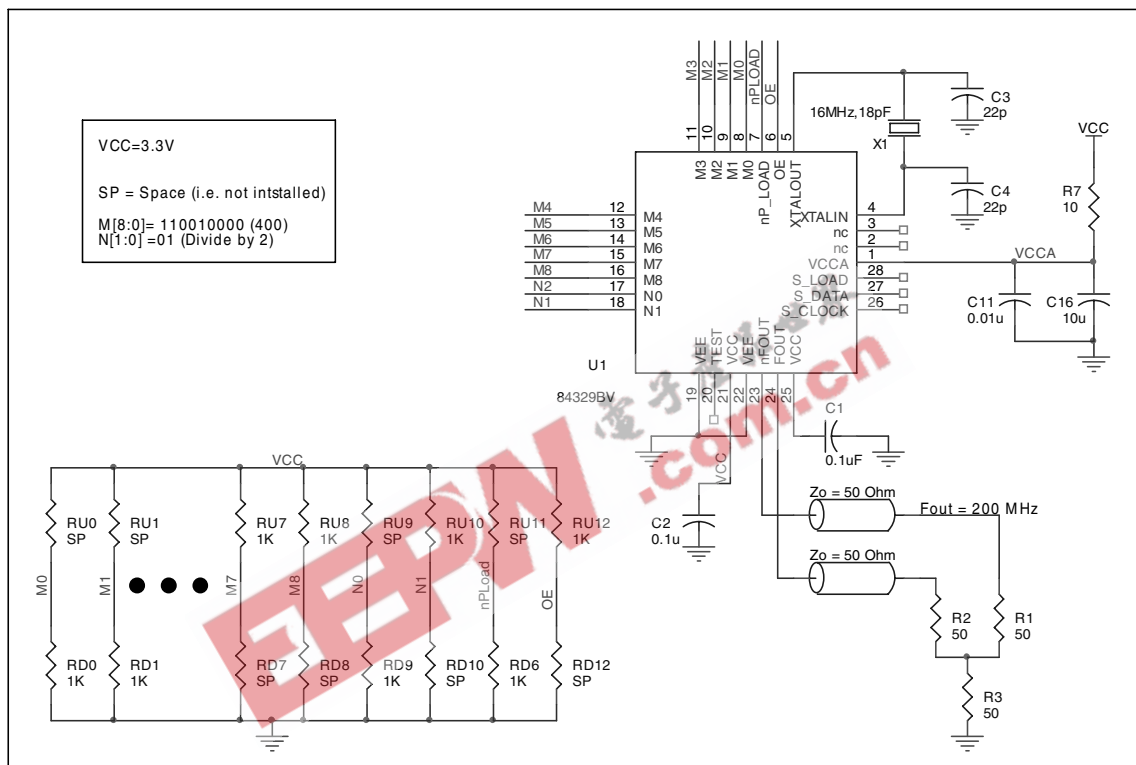

FIGURE 5A. SCHEMATIC OF RECOMMENDED LAYOUT FOR 28 LEAD PLCC



The following component footprints are used in this layout example:

All the resistors and capacitors are size 0603.

### POWER AND GROUNDING

Place the decoupling capacitors C1, C2 and C3, as close as possible to the power pins. If space allows, placement of the decoupling capacitor on the component side is preferred. This can reduce unwanted inductance between the decoupling capacitor and the power pin caused by the via.

Maximize the power and ground pad sizes and number of vias capacitors. This can reduce the inductance between the power and ground planes and the component power and ground pins.

The RC filter consisting of R7, C11, and C16 should be placed as close to the  $V_{CCA}$  pin as possible.

### CLOCK TRACES AND TERMINATION

Poor signal integrity can degrade the system performance or cause system failure. In synchronous high-speed digital systems, the clock signal is less tolerant to poor signal integrity than other signals. Any ringing on the rising or falling edge or excessive ring back can cause system failure. The shape of the trace and the trace delay might be restricted by the available space on the board and the component location. While routing the traces, the clock signal traces should be routed first and should be locked prior to routing other signal traces.

- The differential 50Ω output traces should have the same length.
- Avoid sharp angles on the clock trace. Sharp angle turns cause the characteristic impedance to change on the transmission lines.
- Keep the clock traces on the same layer. Whenever possible, avoid placing vias on the clock traces. Placement of vias on the traces can affect the trace characteristic impedance and hence degrade signal integrity.
- To prevent cross talk, avoid routing other signal traces in parallel with the clock traces. If running parallel traces is unavoidable, allow a separation of at least three trace widths between the differential clock trace and the other signal trace.
- Make sure no other signal traces are routed between the clock trace pair.
- The matching termination resistors should be located as close to the receiver input pins as possible.

### CRYSTAL

The crystal X1 should be located as close as possible to the pins 4 (XTAL\_IN) and 5 (XTAL\_OUT). The trace length between the X1 and U1 should be kept to a minimum to avoid unwanted parasitic inductance and capacitance. Other signal traces should not be routed near the crystal traces.

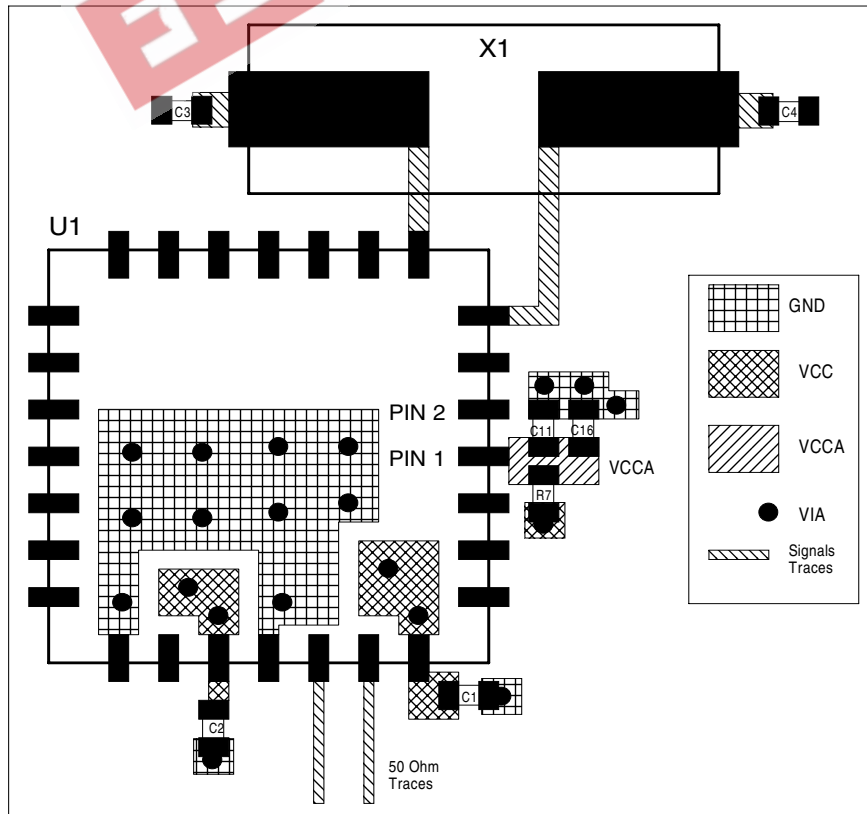

FIGURE 5B. PCB BOARD LAYOUT FOR ICS84329B 28 LEAD PLCC



### TERMINATION FOR LVPECL OUTPUTS

The clock layout topology shown below is a typical termination for LVPECL outputs. The two different layouts mentioned are recommended only as guidelines.

FOUT and nFOUT are low impedance follower outputs that generate ECL/LVPECL compatible outputs. Therefore, terminating resistors (DC current path to ground) or current sources must be used for functionality. These outputs are

designed to drive 50Ω transmission lines. Matched impedance techniques should be used to maximize operating frequency and minimize signal distortion. *Figures 6A and 6B* show two different layouts which are recommended only as guidelines. Other suitable clock layouts may exist and it would be recommended that the board designers simulate to guarantee compatibility across all printed circuit and clock component process variations.

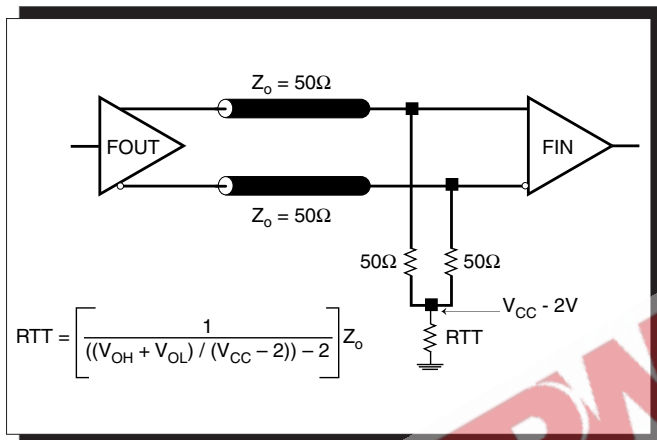

FIGURE 6A. LVPECL OUTPUT TERMINATION

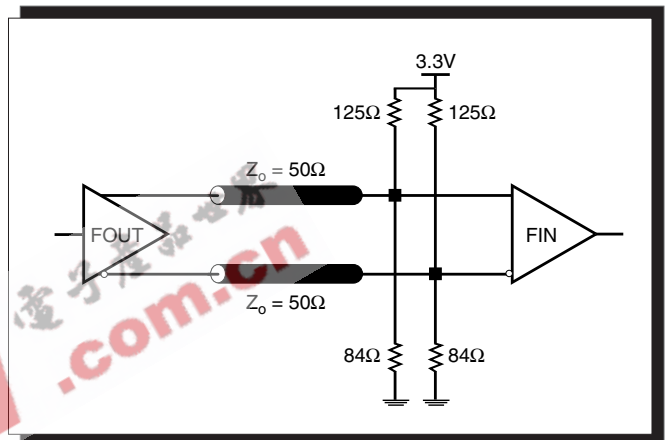

FIGURE 6B. LVPECL OUTPUT TERMINATION



## POWER CONSIDERATIONS

This section provides information on power dissipation and junction temperature for the ICS84329B. Equations and example calculations are also provided.

### 1. Power Dissipation.

The total power dissipation for the ICS84329B is the sum of the core power plus the power dissipated in the load(s). The following is the power dissipation for  $V_{CC} = 3.3V + 5\% = 3.465V$ , which gives worst case results.

**NOTE:** Please refer to Section 3 for details on calculating power dissipated in the load.

- Power (core)<sub>MAX</sub> =  $V_{CC\_MAX} * I_{EE\_MAX} = 3.465V * 140mA = 485mW$
- Power (outputs)<sub>MAX</sub> = **30mW/Loaded Output pair**

$$\text{Total Power}_{MAX} (3.465V, \text{ with all outputs switching}) = 485mW + 30mW = 515mW$$

### 2. Junction Temperature.

Junction temperature,  $T_j$ , is the temperature at the junction of the bond wire and bond pad and directly affects the reliability of the device. The maximum recommended junction temperature for HiPerClockS™ devices is 125°C.

The equation for  $T_j$  is as follows:  $T_j = \theta_{JA} * Pd\_total + T_A$

$T_j$  = Junction Temperature

$\theta_{JA}$  = Junction-to-Ambient Thermal Resistance

$Pd\_total$  = Total Device Power Dissipation (example calculation is in section 1 above)

$T_A$  = Ambient Temperature

In order to calculate junction temperature, the appropriate junction-to-ambient thermal resistance  $\theta_{JA}$  must be used. Assuming a moderate air flow of 200 linear feet per minute and a multi-layer board, the appropriate value is 31.1°C/W per Table 8A below.

Therefore,  $T_j$  for an ambient temperature of 70°C with all outputs switching is:

$$70^\circ C + 0.515W * 31.1^\circ C/W = 86^\circ C. \text{ This is well below the limit of } 125^\circ C.$$

This calculation is only an example.  $T_j$  will obviously vary depending on the number of loaded outputs, supply voltage, air flow, and the type of board (single layer or multi-layer).

**TABLE 8A. THERMAL RESISTANCE  $\theta_{JA}$  FOR 28-PIN PLCC, FORCED CONVECTION**

$\theta_{JA}$ by Velocity (Linear Feet per Minute)			
	0	200	500
Multi-Layer PCB, JEDEC Standard Test Boards	37.8°C/W	31.1°C/W	28.3°C/W

**NOTE:** Most modern PCB designs use multi-layered boards. The data in the second row pertains to most designs.

**TABLE 8B. THERMAL RESISTANCE  $\theta_{JA}$  FOR 32-PIN LQFP, FORCED CONVECTION**

$\theta_{JA}$ by Velocity (Linear Feet per Minute)			
	0	200	500
Single-Layer PCB, JEDEC Standard Test Boards	67.8°C/W	55.9°C/W	50.1°C/W
Multi-Layer PCB, JEDEC Standard Test Boards	47.9°C/W	42.1°C/W	39.4°C/W

**NOTE:** Most modern PCB designs use multi-layered boards. The data in the second row pertains to most designs.



### 3. Calculations and Equations.

The purpose of this section is to derive the power dissipated into the load.

LVPECL output driver circuit and termination are shown in the *Figure 7*.

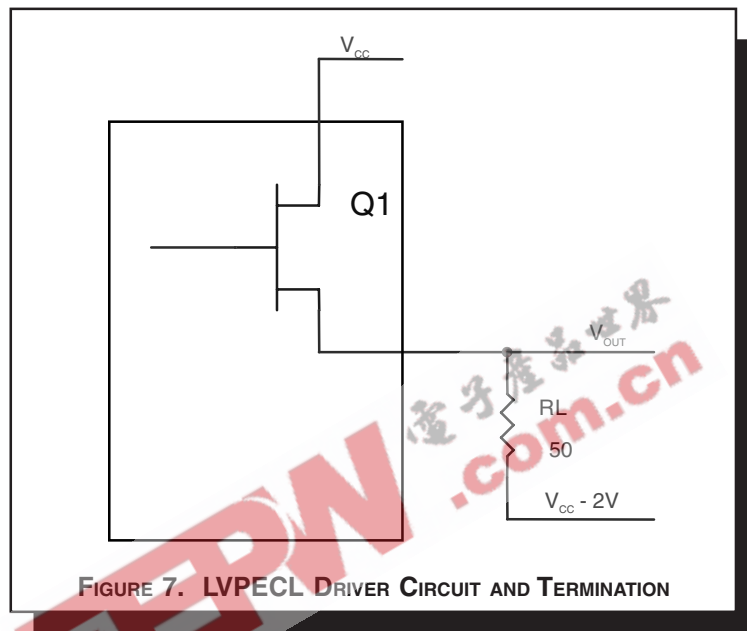

FIGURE 7. LVPECL DRIVER CIRCUIT AND TERMINATION

To calculate worst case power dissipation into the load, use the following equations which assume a 50Ω load, and a termination voltage of  $V_{CC} - 2V$ .

- For logic high,  $V_{OUT} = V_{OH\_MAX} = V_{CC\_MAX} - 0.9V$

$$(V_{CC\_MAX} - V_{OH\_MAX}) = 0.9V$$

- For logic low,  $V_{OUT} = V_{OL\_MAX} = V_{CC\_MAX} - 1.7V$

$$(V_{CC\_MAX} - V_{OL\_MAX}) = 1.7V$$

$Pd\_H$  is power dissipation when the output drives high.  
 $Pd\_L$  is the power dissipation when the output drives low.

$$Pd\_H = [(V_{OH\_MAX} - (V_{CC\_MAX} - 2V))/R_L] * (V_{CC\_MAX} - V_{OH\_MAX}) = [(2V - (V_{CC\_MAX} - V_{OH\_MAX}))/R_L] * (V_{CC\_MAX} - V_{OH\_MAX}) = [(2V - 0.9V)/50\Omega] * 0.9V = 19.8mW$$

$$Pd\_L = [(V_{OL\_MAX} - (V_{CC\_MAX} - 2V))/R_L] * (V_{CC\_MAX} - V_{OL\_MAX}) = [(2V - (V_{CC\_MAX} - V_{OL\_MAX}))/R_L] * (V_{CC\_MAX} - V_{OL\_MAX}) = [(2V - 1.7V)/50\Omega] * 1.7V = 10.2mW$$

Total Power Dissipation per output pair =  $Pd\_H + Pd\_L = 30mW$



Integrated  
Circuit  
Systems, Inc.

**ICS84329B**  
700MHz, Low JITTER, CRYSTAL-TO-3.3V  
DIFFERENTIAL LVPECL FREQUENCY SYNTHESIZER

**RELIABILITY INFORMATION**

**TABLE 9A.  $\theta_{JA}$  VS. AIR FLOW TABLE FOR 28 LEAD PLCC**

$\theta_{JA}$ by Velocity (Linear Feet per Minute)			
	0	200	500
Multi-Layer PCB, JEDEC Standard Test Boards	37.8°C/W	31.1°C/W	28.3°C/W

**NOTE:** Most modern PCB designs use multi-layered boards. The data in the second row pertains to most designs.

**TABLE 9B.  $\theta_{JA}$  VS. AIR FLOW TABLE FOR 32 LEAD LQFP**

$\theta_{JA}$ by Velocity (Linear Feet per Minute)			
	0	200	500
Single-Layer PCB, JEDEC Standard Test Boards	67.8°C/W	55.9°C/W	50.1°C/W
Multi-Layer PCB, JEDEC Standard Test Boards	47.9°C/W	42.1°C/W	39.4°C/W

**NOTE:** Most modern PCB designs use multi-layered boards. The data in the second row pertains to most designs.

**TRANSISTOR COUNT**

The transistor count for ICS84329B is: 4408

Pin compatible with the MC12429



Integrated  
Circuit  
Systems, Inc.

# ICS84329B

700MHz, Low JITTER, CRYSTAL-TO-3.3V  
DIFFERENTIAL LVPECL FREQUENCY SYNTHESIZER

## PACKAGE OUTLINE - V SUFFIX FOR 28 LEAD PLCC

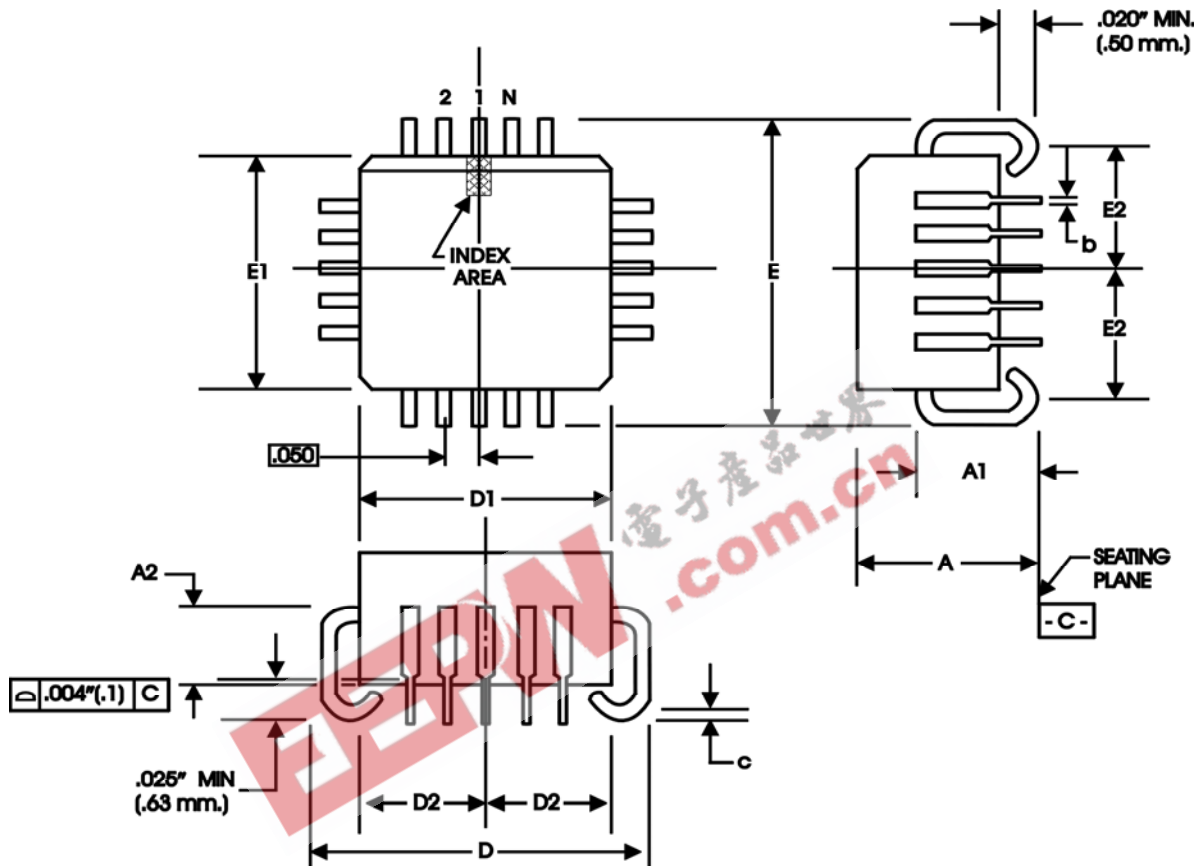

TABLE 10A. PACKAGE DIMENSIONS

JEDEC VARIATION		
ALL DIMENSIONS IN MILLIMETERS		
SYMBOL	MINIMUM	MAXIMUM
N	28	
A	4.19	4.57
A1	2.29	3.05
A2	1.57	2.11
b	0.33	0.53
c	0.19	0.32
D	12.32	12.57
D1	11.43	11.58
D2	4.85	5.56
E	12.32	12.57
E1	11.43	11.58
E2	4.85	5.56

Reference Document: JEDEC Publication 95, MS-018





Integrated  
Circuit  
Systems, Inc.

# ICS84329B

700MHz, Low JITTER, CRYSTAL-TO-3.3V  
DIFFERENTIAL LVPECL FREQUENCY SYNTHESIZER

## PACKAGE OUTLINE - Y SUFFIX 32 LEAD LQFP

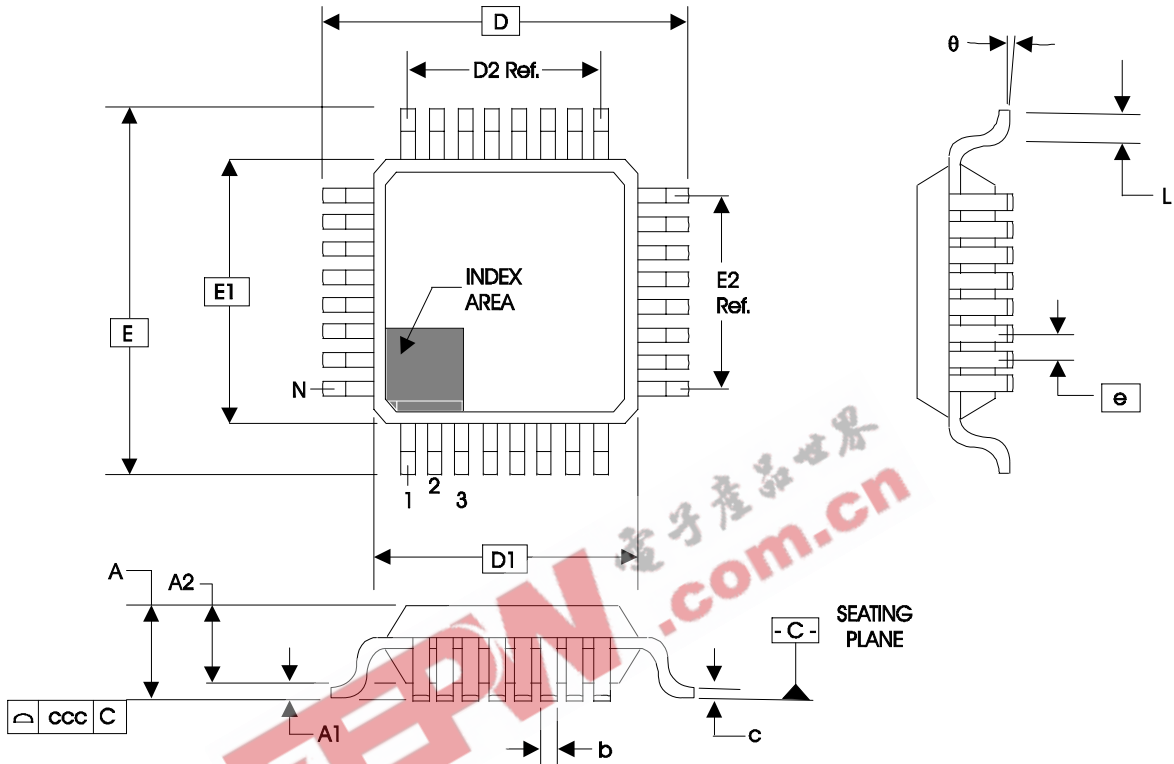

TABLE 10B. PACKAGE DIMENSIONS

JEDEC VARIATION ALL DIMENSIONS IN MILLIMETERS			
SYMBOL	BBA		
	MINIMUM	NOMINAL	MAXIMUM
N	32		
A	--	--	1.60
A1	0.05	--	0.15
A2	1.35	1.40	1.45
b	0.30	0.37	0.45
c	0.09	--	0.20
D	9.00 BASIC		
D1	7.00 BASIC		
D2	5.60 Ref.		
E	9.00 BASIC		
E1	7.00 BASIC		
E2	5.60 Ref.		
e	0.80 BASIC		
L	0.45	0.60	0.75
theta	0°	--	7°
ccc	--	--	0.10

Reference Document: JEDEC Publication 95, MS-026



Integrated  
Circuit  
Systems, Inc.

# ICS84329B

## 700MHz, Low JITTER, CRYSTAL-TO-3.3V DIFFERENTIAL LVPECL FREQUENCY SYNTHESIZER

TABLE 11. ORDERING INFORMATION

Part/Order Number	Marking	Package	Shipping Packaging	Temperature
ICS84329BV	ICS84329BV	28 Lead PLCC	Tube	0°C to 70°C
ICS84329BVT	ICS84329BV	28 Lead PLCC	500 Tape & Reel	0°C to 70°C
ICS84329BVLF	ICS84329BVLF	28 Lead "Lead-Free" PLCC	Tube	0°C to 70°C
ICS84329BVLFT	ICS84329BVLF	28 Lead "Lead-Free" PLCC	500 Tape & Reel	0°C to 70°C
ICS84329BY	ICS84329BY	32 Lead LQFP	Tray	0°C to 70°C
ICS84329BYT	ICS84329BY	32 Lead LQFP	1000 Tape & Reel	0°C to 70°C
ICS84329BYLF	ICS84329BYLF	32 Lead "Lead-Free" LQFP	Tray	0°C to 70°C
ICS84329BYLFT	ICS84329BYLF	32 Lead "Lead-Free" LQFP	1000 Tape & Reel	0°C to 70°C

NOTE: Parts that are ordered with an "LF" suffix to the part number are the Pb-Free configuration and are RoHS compliant.

EEPW.com.cn 电子產品世界

The aforementioned trademark, HiPerClockS™ is a trademark of Integrated Circuit Systems, Inc. or its subsidiaries in the United States and/or other countries. While the information presented herein has been checked for both accuracy and reliability, Integrated Circuit Systems, Incorporated (ICS) assumes no responsibility for either its use or for infringement of any patents or other rights of third parties, which would result from its use. No other circuits, patents, or licenses are implied. This product is intended for use in normal commercial applications. Any other applications such as those requiring extended temperature range, high reliability, or other extraordinary environmental requirements are not recommended without additional processing by ICS. ICS reserves the right to change any circuitry or specifications without notice. ICS does not authorize or warrant any ICS product for use in life support devices or critical medical instruments.



Integrated  
Circuit  
Systems, Inc.

**ICS84329B**  
700MHz, Low JITTER, CRYSTAL-TO-3.3V  
DIFFERENTIAL LVPECL FREQUENCY SYNTHESIZER

REVISION HISTORY SHEET

Rev	Table	Page	Description of Change	Date
A		1	Features Section - added "Parallel resonant" to crystal bullet.	12/15/04
B	T5 T11	1	Features Section - corrected Output frequency range from 25MHz to 31.25MHz. Added Lead-Free bullet.	6/10/05
		2	Updated Parallel & Serial Load Operations.	
		6	Crystal Table - added Drive Level.	
B	T11	17	Ordering Information Table - added Lead-Free part numbers and note.	1/18/06
		8	Power Supply Filtering Techniques - added ferrite bead sentence.	
		8	Added <i>Recommendations for Unused Input and Output Pins</i> .	
		18	Ordering Information Table - added Lead-Free marking.	

EEPW 电子产品世界  
.com.cn