

## LM78LXX Series 3-Terminal Positive Regulators

### General Description

The LM78LXX series of three terminal positive regulators is available with several fixed output voltages making them useful in a wide range of applications. When used as a zener diode/resistor combination replacement, the LM78LXX usually results in an effective output impedance improvement of two orders of magnitude, and lower quiescent current. These regulators can provide local on card regulation, eliminating the distribution problems associated with single point regulation. The voltages available allow the LM78LXX to be used in logic systems, instrumentation, HiFi, and other solid state electronic equipment.

The LM78LXX is available in the plastic TO-92 (Z) package, the plastic SO-8 (M) package and a chip sized package (8-Bump micro SMD) using National's micro SMD package technology. With adequate heat sinking the regulator can deliver 100 mA output current. Current limiting is included to limit the peak output current to a safe value. Safe area pro-

tection for the output transistors is provided to limit internal power dissipation. If internal power dissipation becomes too high for the heat sinking provided, the thermal shutdown circuit takes over preventing the IC from overheating.

### Features

- LM78L05 in micro SMD package
- Output voltage tolerances of  $\pm 5\%$  over the temperature range
- Output current of 100 mA
- Internal thermal overload protection
- Output transistor safe area protection
- Internal short circuit current limit
- Available in plastic TO-92 and plastic SO-8 low profile packages
- No external components
- Output voltages of 5.0V, 6.2V, 8.2V, 9.0V, 12V, 15V

### Connection Diagrams

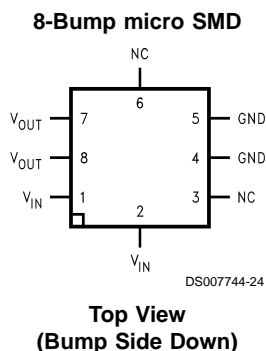
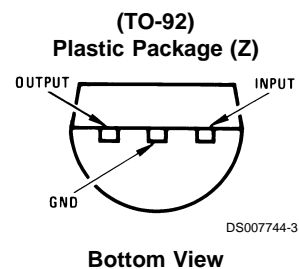
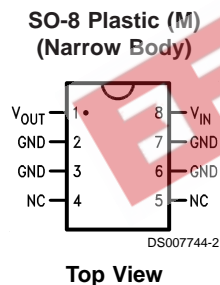

### micro SMD Marking Orientation

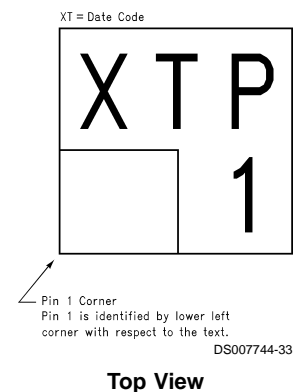

**Absolute Maximum Ratings** (Note 1)

If Military/Aerospace specified devices are required, please contact the National Semiconductor Sales Office/Distributors for availability and specifications.

Power Dissipation (Note 5)	Internally Limited
Input Voltage	35V
Storage Temperature	-65°C to +150°C

Operating Junction Temperature

SO-8	0°C to 125°C
micro SMD	-40°C to 85°C

Soldering Information

Infrared or Convection (20 sec.)	235°C
Wave Soldering (10 sec.)	260°C (lead time)
ESD Susceptibility (Note 2)	1kV

**LM78LXX Electrical Characteristics** Limits in standard typeface are for  $T_J = 25^\circ\text{C}$ , **Bold typeface applies over 0°C to 125°C for SO-8 package and -40°C to 85°C for micro SMD package.** Limits are guaranteed by production testing or correlation techniques using standard Statistical Quality Control (SQC) methods. Unless otherwise specified:  $I_O = 40\text{ mA}$ ,  $C_I = 0.33\ \mu\text{F}$ ,  $C_O = 0.1\ \mu\text{F}$ .

**LM78L05**Unless otherwise specified,  $V_{IN} = 10\text{V}$ 

Symbol	Parameter	Conditions	Min	Typ	Max	Units
$V_O$	Output Voltage		4.8	5	5.2	V
		$7\text{V} \leq V_{IN} \leq 20\text{V}$ $1\text{ mA} \leq I_O \leq 40\text{ mA}$ (Note 3)	<b>4.75</b>		<b>5.25</b>	
		$1\text{ mA} \leq I_O \leq 70\text{ mA}$ (Note 3)	<b>4.75</b>		<b>5.25</b>	
$\Delta V_O$	Line Regulation	$7\text{V} \leq V_{IN} \leq 20\text{V}$		18	75	mV
		$8\text{V} \leq V_{IN} \leq 20\text{V}$		10	54	
$\Delta V_O$	Load Regulation	$1\text{ mA} \leq I_O \leq 100\text{ mA}$		20	60	mV
		$1\text{ mA} \leq I_O \leq 40\text{ mA}$		5	30	
$I_Q$	Quiescent Current			3	5	mA
$\Delta I_Q$	Quiescent Current Change	$8\text{V} \leq V_{IN} \leq 20\text{V}$ $1\text{ mA} \leq I_O \leq 40\text{ mA}$			<b>1.0</b> <b>0.1</b>	
$V_n$	Output Noise Voltage	$f = 10\text{ Hz to } 100\text{ kHz}$ (Note 4)		40		$\mu\text{V}$
$\frac{\Delta V_{IN}}{\Delta V_{OUT}}$	Ripple Rejection	$f = 120\text{ Hz}$ $8\text{V} \leq V_{IN} \leq 16\text{V}$	47	62		dB
$I_{PK}$	Peak Output Current			140		mA
$\frac{\Delta V_O}{\Delta T}$	Average Output Voltage Tempco	$I_O = 5\text{ mA}$		-0.65		$\text{mV}/^\circ\text{C}$
$V_{IN}(\text{Min})$	Minimum Value of Input Voltage Required to Maintain Line Regulation			6.7	7	V
$\theta_{JA}$	Thermal Resistance (8-Bump micro SMD)			230.9		$^\circ\text{C}/\text{W}$

**LM78L62AC**Unless otherwise specified,  $V_{IN} = 12\text{V}$ 

Symbol	Parameter	Conditions	Min	Typ	Max	Units
$V_O$	Output Voltage		5.95	6.2	6.45	V
		$8.5\text{V} \leq V_{IN} \leq 20\text{V}$ $1\text{ mA} \leq I_O \leq 40\text{ mA}$ (Note 3)	<b>5.9</b>		<b>6.5</b>	
		$1\text{ mA} \leq I_O \leq 70\text{ mA}$ (Note 3)	<b>5.9</b>		<b>6.5</b>	
$\Delta V_O$	Line Regulation	$8.5\text{V} \leq V_{IN} \leq 20\text{V}$		65	175	mV
		$9\text{V} \leq V_{IN} \leq 20\text{V}$		55	125	
$\Delta V_O$	Load Regulation	$1\text{ mA} \leq I_O \leq 100\text{ mA}$		13	80	mV
		$1\text{ mA} \leq I_O \leq 40\text{ mA}$		6	40	

**LM78L62AC** (Continued)Unless otherwise specified,  $V_{IN} = 12V$ 

Symbol	Parameter	Conditions	Min	Typ	Max	Units
$I_Q$	Quiescent Current			2	5.5	mA
$\Delta I_Q$	Quiescent Current Change	$8V \leq V_{IN} \leq 20V$ $1 mA \leq I_O \leq 40 mA$			1.5 0.1	
$V_n$	Output Noise Voltage	$f = 10 Hz$ to 100 kHz (Note 4)		50		$\mu V$
$\frac{\Delta V_{IN}}{\Delta V_{OUT}}$	Ripple Rejection	$f = 120 Hz$ $10V \leq V_{IN} \leq 20V$	40	46		dB
$I_{PK}$	Peak Output Current			140		mA
$\frac{\Delta V_O}{\Delta T}$	Average Output Voltage Tempco	$I_O = 5 mA$		-0.75		$mV/^\circ C$
$V_{IN} (Min)$	Minimum Value of Input Voltage Required to Maintain Line Regulation			7.9		V

**LM78L82AC**Unless otherwise specified,  $V_{IN} = 14V$ 

Symbol	Parameter	Conditions	Min	Typ	Max	Units
$V_O$	Output Voltage		7.87	8.2	8.53	V
		$11V \leq V_{IN} \leq 23V$ $1 mA \leq I_O \leq 40 mA$ (Note 3)	7.8		8.6	
		$1 mA \leq I_O \leq 70 mA$ (Note 3)	7.8		8.6	
$\Delta V_O$	Line Regulation	$11V \leq V_{IN} \leq 23V$		80	175	mV
		$12V \leq V_{IN} \leq 23V$		70	125	
$\Delta V_O$	Load Regulation	$1 mA \leq I_O \leq 100 mA$		15	80	
		$1 mA \leq I_O \leq 40 mA$		8	40	
$I_Q$	Quiescent Current			2	5.5	mA
$\Delta I_Q$	Quiescent Current Change	$12V \leq V_{IN} \leq 23V$ $1 mA \leq I_O \leq 40 mA$			1.5 0.1	
$V_n$	Output Noise Voltage	$f = 10 Hz$ to 100 kHz (Note 4)		60		$\mu V$
$\frac{\Delta V_{IN}}{\Delta V_{OUT}}$	Ripple Rejection	$f = 120 Hz$ $12V \leq V_{IN} \leq 22V$	39	45		dB
$I_{PK}$	Peak Output Current			140		mA
$\frac{\Delta V_O}{\Delta T}$	Average Output Voltage Tempco	$I_O = 5 mA$		-0.8		$mV/^\circ C$
$V_{IN} (Min)$	Minimum Value of Input Voltage Required to Maintain Line Regulation			9.9		V

**LM78L09AC**Unless otherwise specified,  $V_{IN} = 15V$ 

Symbol	Parameter	Conditions	Min	Typ	Max	Units
$V_O$	Output Voltage		8.64	9.0	9.36	V
		$11.5V \leq V_{IN} \leq 24V$ $1 mA \leq I_O \leq 40 mA$ (Note 3)	8.55		9.45	
		$1 mA \leq I_O \leq 70 mA$ (Note 3)	8.55		9.45	

**LM78L09AC** (Continued)Unless otherwise specified,  $V_{IN} = 15V$ 

Symbol	Parameter	Conditions	Min	Typ	Max	Units
$\Delta V_O$	Line Regulation	$11.5V \leq V_{IN} \leq 24V$		100	200	mV
		$13V \leq V_{IN} \leq 24V$		90	150	
$\Delta V_O$	Load Regulation	$1 mA \leq I_O \leq 100 mA$		20	90	mV
		$1 mA \leq I_O \leq 40 mA$		10	45	
$I_Q$	Quiescent Current			2	5.5	mA
$\Delta I_Q$	Quiescent Current Change	$11.5V \leq V_{IN} \leq 24V$			<b>1.5</b>	
		$1 mA \leq I_O \leq 40 mA$			<b>0.1</b>	
$V_n$	Output Noise Voltage			70		$\mu V$
$\frac{\Delta V_{IN}}{\Delta V_{OUT}}$	Ripple Rejection	$f = 120 Hz$ $15V \leq V_{IN} \leq 25V$	38	44		dB
$I_{PK}$	Peak Output Current			140		mA
$\frac{\Delta V_O}{\Delta T}$	Average Output Voltage Tempco	$I_O = 5 mA$		-0.9		mV/°C
$V_{IN} (Min)$	Minimum Value of Input Voltage Required to Maintain Line Regulation			10.7		V

**LM78L12AC**Unless otherwise specified,  $V_{IN} = 19V$ 

Symbol	Parameter	Conditions	Min	Typ	Max	Units
$V_O$	Output Voltage		11.5	12	12.5	V
		$14.5V \leq V_{IN} \leq 27V$ $1 mA \leq I_O \leq 40 mA$ (Note 3)	<b>11.4</b>		<b>12.6</b>	
		$1 mA \leq I_O \leq 70 mA$ (Note 3)	<b>11.4</b>		<b>12.6</b>	
$\Delta V_O$	Line Regulation	$14.5V \leq V_{IN} \leq 27V$		30	180	mV
		$16V \leq V_{IN} \leq 27V$		20	110	
$\Delta V_O$	Load Regulation	$1 mA \leq I_O \leq 100 mA$		30	100	mV
		$1 mA \leq I_O \leq 40 mA$		10	50	
$I_Q$	Quiescent Current			3	5	mA
$\Delta I_Q$	Quiescent Current Change	$16V \leq V_{IN} \leq 27V$			<b>1</b>	
		$1 mA \leq I_O \leq 40 mA$			<b>0.1</b>	
$V_n$	Output Noise Voltage			80		$\mu V$
$\frac{\Delta V_{IN}}{\Delta V_{OUT}}$	Ripple Rejection	$f = 120 Hz$ $15V \leq V_{IN} \leq 25$	40	54		dB
$I_{PK}$	Peak Output Current			140		mA
$\frac{\Delta V_O}{\Delta T}$	Average Output Voltage Tempco	$I_O = 5 mA$		-1.0		mV/°C
$V_{IN} (Min)$	Minimum Value of Input Voltage Required to Maintain Line Regulation			13.7	14.5	V

**LM78L15AC**Unless otherwise specified,  $V_{IN} = 23V$ 

Symbol	Parameter	Conditions	Min	Typ	Max	Units
$V_O$	Output Voltage		14.4	15.0	15.6	V
		$17.5V \leq V_{IN} \leq 30V$ $1 \text{ mA} \leq I_O \leq 40 \text{ mA}$ (Note 3)	<b>14.25</b>		<b>15.75</b>	
		$1 \text{ mA} \leq I_O \leq 70 \text{ mA}$ (Note 3)	<b>14.25</b>		<b>15.75</b>	
$\Delta V_O$	Line Regulation	$17.5V \leq V_{IN} \leq 30V$		37	250	mV
		$20V \leq V_{IN} \leq 30V$		25	140	
$\Delta V_O$	Load Regulation	$1 \text{ mA} \leq I_O \leq 100 \text{ mA}$		35	150	
		$1 \text{ mA} \leq I_O \leq 40 \text{ mA}$		12	75	
$I_Q$	Quiescent Current			3	5	mA
$\Delta I_Q$	Quiescent Current Change	$20V \leq V_{IN} \leq 30V$			<b>1</b>	
		$1 \text{ mA} \leq I_O \leq 40 \text{ mA}$			<b>0.1</b>	
$V_n$	Output Noise Voltage			90		$\mu V$
$\frac{\Delta V_{IN}}{\Delta V_{OUT}}$	Ripple Rejection	$f = 120 \text{ Hz}$ $18.5V \leq V_{IN} \leq 28.5V$	37	51		dB
$I_{PK}$	Peak Output Current			140		mA
$\frac{\Delta V_O}{\Delta T}$	Average Output Voltage Tempco	$I_O = 5 \text{ mA}$		-1.3		$mV/^\circ C$
$V_{IN} \text{ (Min)}$	Minimum Value of Input Voltage Required to Maintain Line Regulation			16.7	17.5	V

**Note 1:** Absolute Maximum Ratings indicate limits beyond which damage to the device may occur. Electrical specifications do not apply when operating the device outside of its stated operating conditions.

**Note 2:** Human body model, 1.5 k $\Omega$  in series with 100 pF.

**Note 3:** Power dissipation  $\leq 0.75W$ .

**Note 4:** Recommended minimum load capacitance of 0.01  $\mu F$  to limit high frequency noise.

**Note 5:** Typical thermal resistance values for the packages are:

**Z** Package:  $\theta_{JC} = 60 \text{ }^\circ C/W$ ,  $\theta_{JA} = 230 \text{ }^\circ C/W$

**M** Package:  $\theta_{JA} = 180 \text{ }^\circ C/W$

**micro SMD** Package:  $\theta_{JA} = 230.9 \text{ }^\circ C/W$

## Typical Performance Characteristics

Maximum Average Power Dissipation (Z Package)

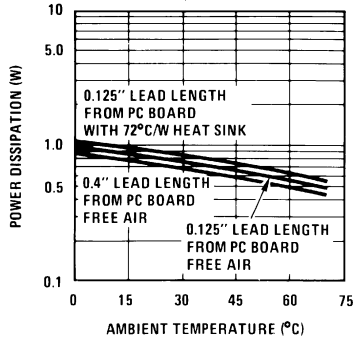

Peak Output Current

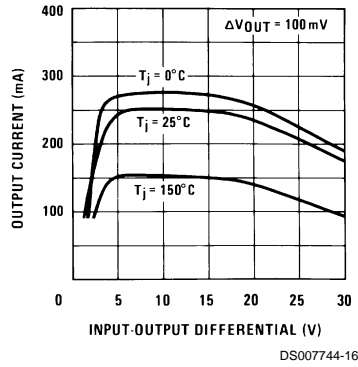

Dropout Voltage

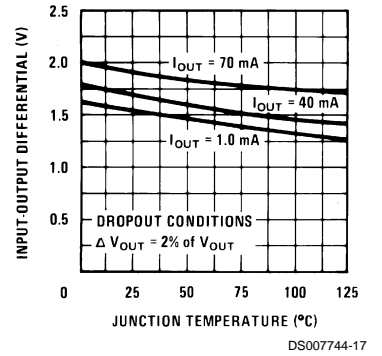

Ripple Rejection

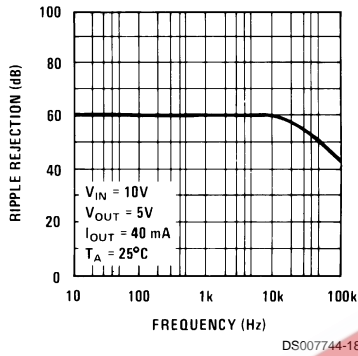

Output Impedance

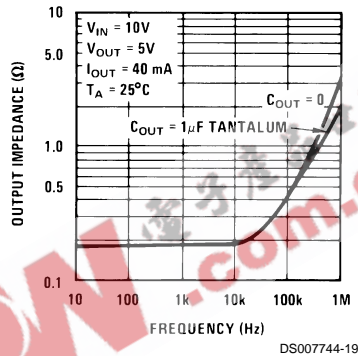

Quiescent Current

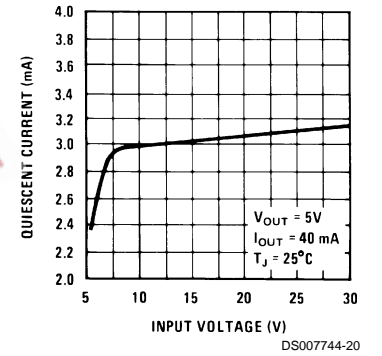

Quiescent Current

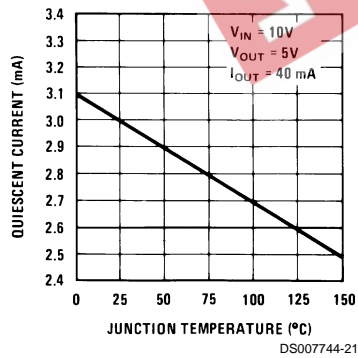

### Equivalent Circuit

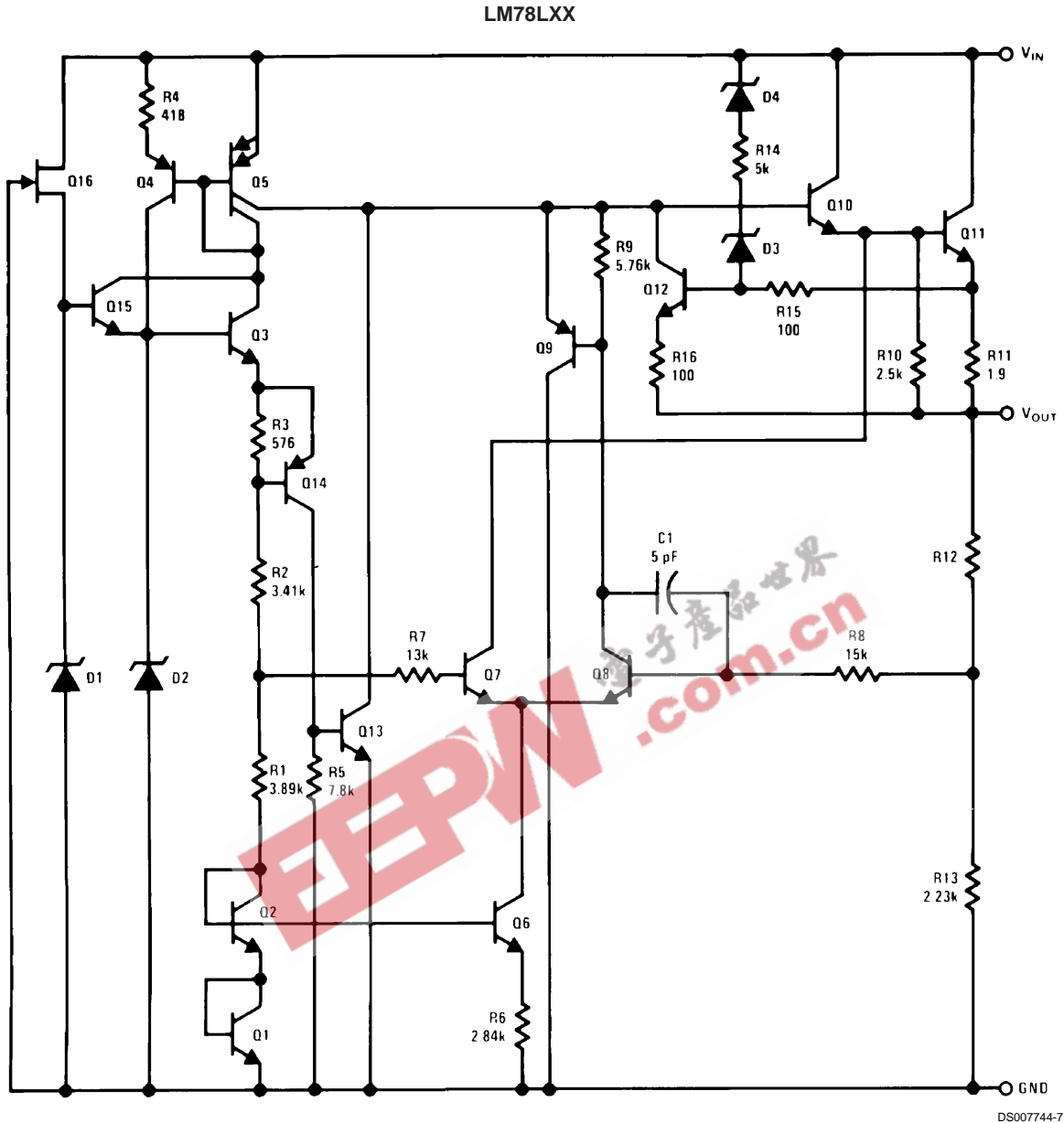

DS007744-7

### Typical Applications

#### Fixed Output Regulator

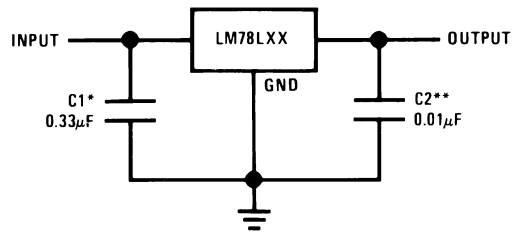

DS007744-8

\*Required if the regulator is located more than 3" from the power supply filter.

\*\*See (Note 4) in the electrical characteristics table.

## Typical Applications (Continued)

### Adjustable Output Regulator

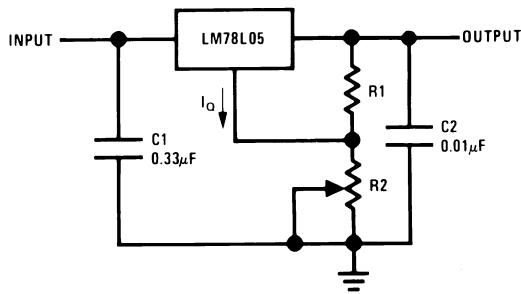

DS007744-9

$$V_{OUT} = 5V + (5V/R1 + I_Q) R2$$

$$5V/R1 > 3 I_Q, \text{ load regulation } (L_r) \approx [(R1 + R2)/R1] (L_r \text{ of LM78L05})$$

### Current Regulator

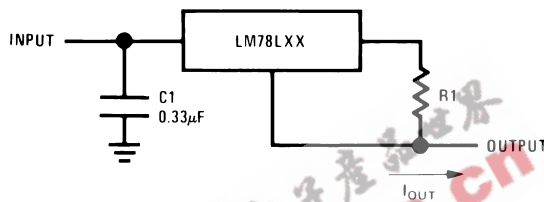

DS007744-10

$$I_{OUT} = (V_{OUT}/R1) + I_Q$$

$$> I_Q = 1.5 \text{ mA over line and load changes}$$

### 5V, 500 mA Regulator with Short Circuit Protection

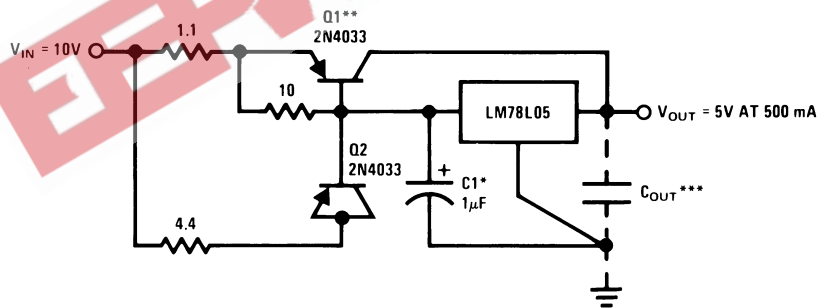

DS007744-11

\*Solid tantalum.  
 \*\*Heat sink Q1.  
 \*\*\*Optional: Improves ripple rejection and transient response.  
 Load Regulation: 0.6%  $0 \leq I_L \leq 250 \text{ mA}$  pulsed with  $t_{ON} = 50 \text{ ms}$ .

### ±15V, 100 mA Dual Power Supply

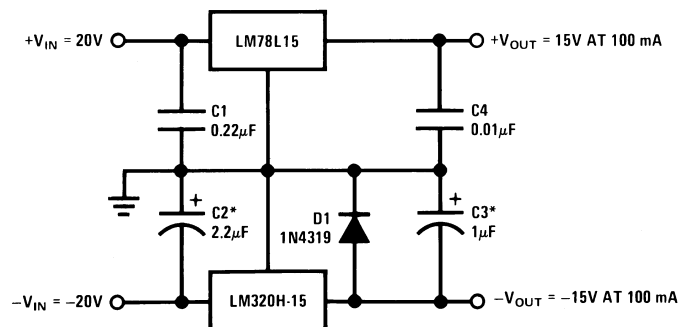

DS007744-12

\*Solid tantalum.



Typical Applications (Continued)

Variable Output Regulator 0.5V-18V

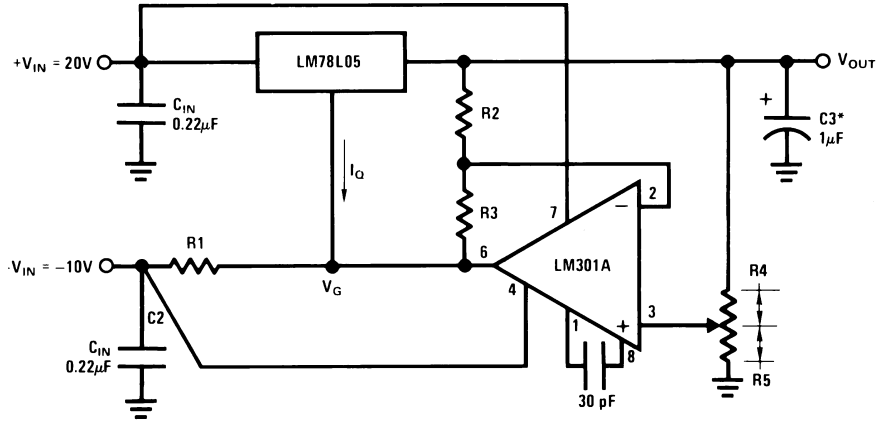

DS007744-13

\*Solid tantalum.

$$V_{OUT} = V_G + 5V, R1 = (-V_{IN}/I_Q \text{ LM78L05})$$

$$V_{OUT} = 5V (R2/R4) \text{ for } (R2 + R3) = (R4 + R5)$$

A 0.5V output will correspond to  $(R2/R4) = 0.1$   $(R3/R4) = 0.9$



**Physical Dimensions** inches (millimeters) unless otherwise noted

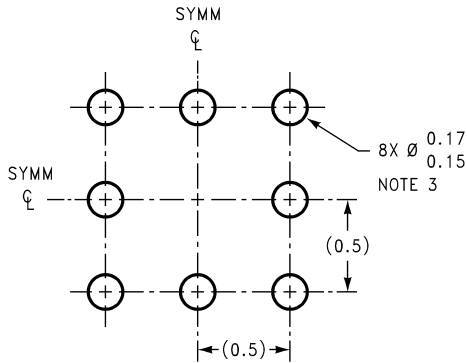

**LAND PATTERN RECOMMENDATION**

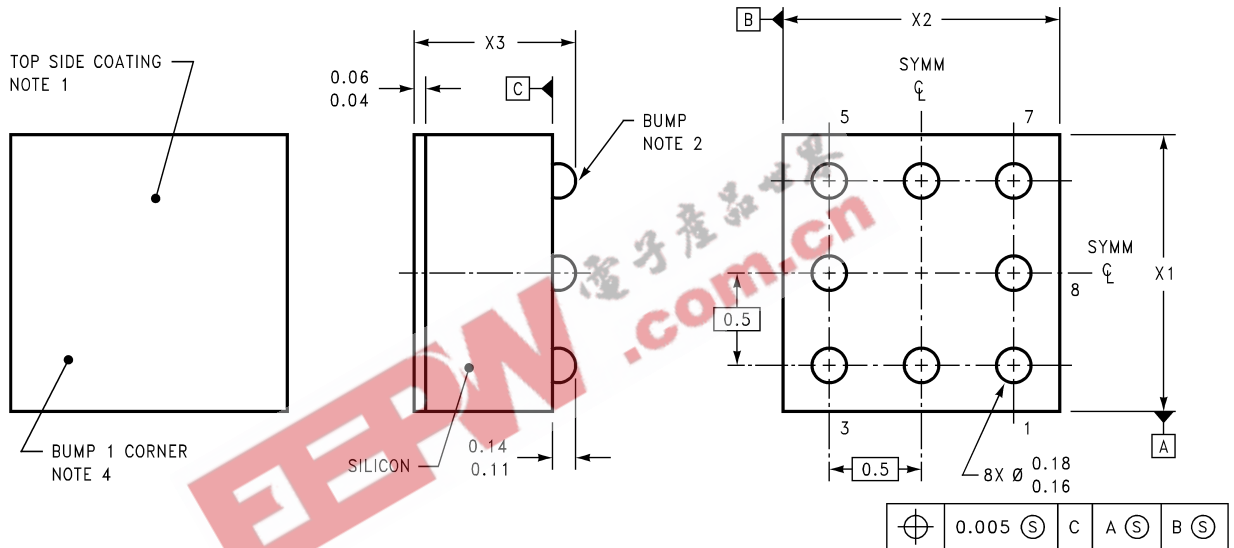

**DIMENSIONS ARE IN MILLIMETERS**

BPA08XXX (REV A)

NOTES: UNLESS OTHERWISE SPECIFIED

1. EPOXY COATING
2. 63Sn/37Pb EUTECTIC BUMP
3. RECOMMEND NON-SOLDER MASK DEFINED LANDING PAD.
4. PIN 1 IS ESTABLISHED BY LOWER LEFT CORNER WITH RESPECT TO TEXT ORIENTATION. REMAINING PINS ARE NUMBERED COUNTERCLOCKWISE.
5. XXX IN DRAWING NUMBER REPRESENTS PACKAGE SIZE VARIATION WHERE  $X_1$  IS PACKAGE WIDTH,  $X_2$  IS PACKAGE LENGTH AND  $X_3$  IS PACKAGE HEIGHT.
6. REFERENCE JEDEC REGISTRATION MO-211, VARIATION BC.

**8-Bump micro SMD**  
**Order Number LM78L05IBP or LM78L05IBPX**  
**NS Package Number BPA08AAA**  
 $X_1 = 1.285$   $X_2 = 1.285$   $X_3 = 0.7$

**Physical Dimensions** inches (millimeters) unless otherwise noted (Continued)

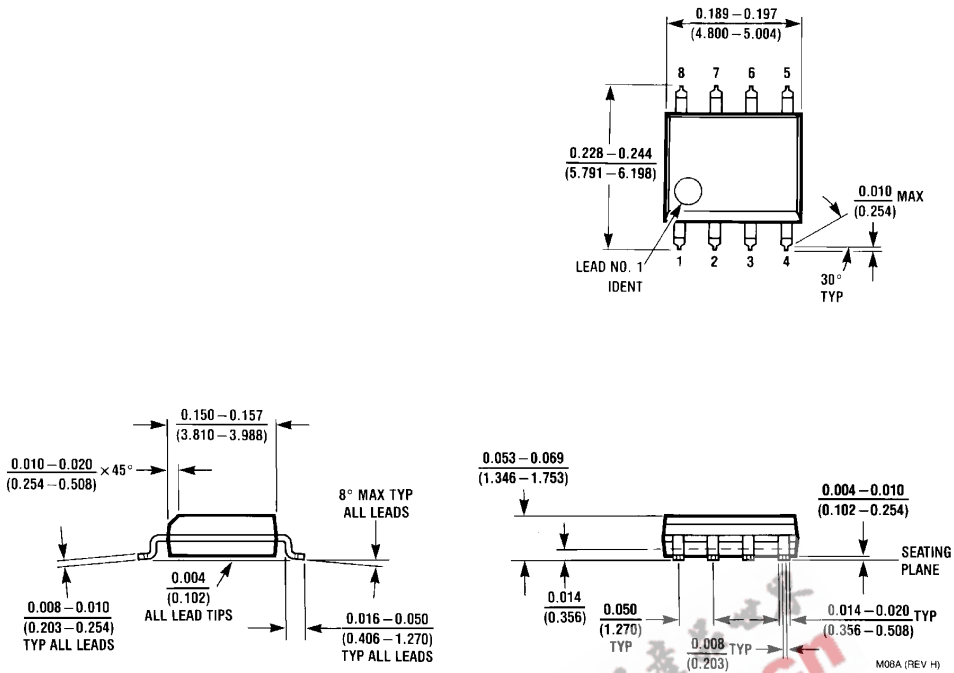

**S.O. Package (M)**  
**Order Number LM78L05ACM, LM78L12ACM or LM78L15ACM**  
**NS Package Number M08A**

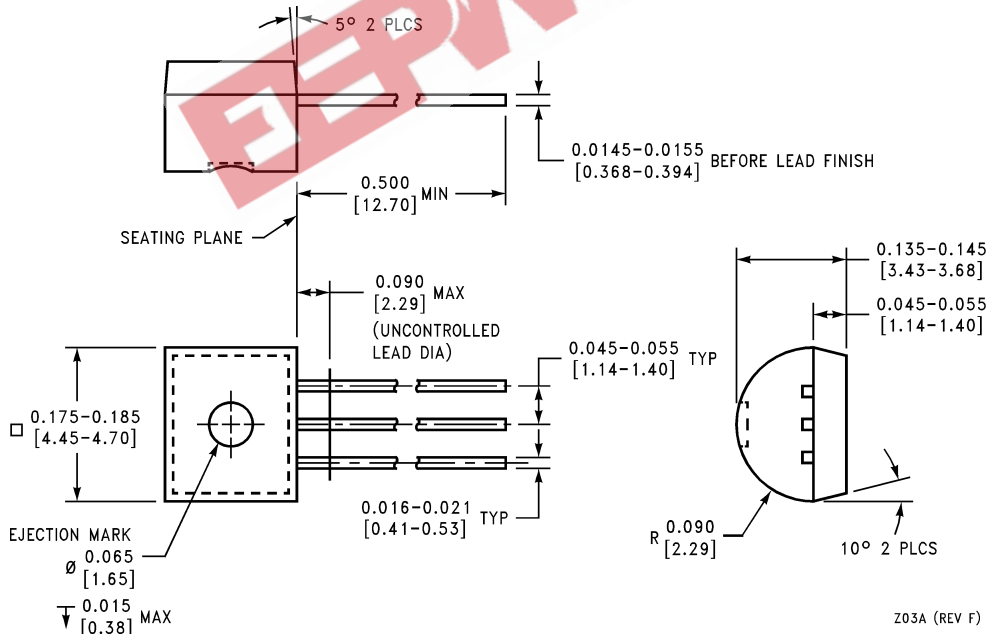

**Molded Offset TO-92 (Z)**  
**Order Number LM78L05ACZ, LM78L09ACZ, LM78L12ACZ,**  
**LM78L15ACZ, LM78L62ACZ or LM78L82ACZ**  
**NS Package Number Z03A**

## Notes

EEPW 电子產品世界  
 .com.cn

**LIFE SUPPORT POLICY**

NATIONAL'S PRODUCTS ARE NOT AUTHORIZED FOR USE AS CRITICAL COMPONENTS IN LIFE SUPPORT DEVICES OR SYSTEMS WITHOUT THE EXPRESS WRITTEN APPROVAL OF THE PRESIDENT AND GENERAL COUNSEL OF NATIONAL SEMICONDUCTOR CORPORATION. As used herein:

1. Life support devices or systems are devices or systems which, (a) are intended for surgical implant into the body, or (b) support or sustain life, and whose failure to perform when properly used in accordance with instructions for use provided in the labeling, can be reasonably expected to result in a significant injury to the user.
2. A critical component is any component of a life support device or system whose failure to perform can be reasonably expected to cause the failure of the life support device or system, or to affect its safety or effectiveness.



**National Semiconductor Corporation**  
 Americas  
 Tel: 1-800-272-9959  
 Fax: 1-800-737-7018  
 Email: support@nsc.com

www.national.com

**National Semiconductor Europe**  
 Fax: +49 (0) 1 80-530 85 86  
 Email: europe.support@nsc.com  
 Deutsch Tel: +49 (0) 1 80-530 85 85  
 English Tel: +49 (0) 1 80-532 78 32  
 Français Tel: +49 (0) 1 80-532 93 58  
 Italiano Tel: +49 (0) 1 80-534 16 80

**National Semiconductor Asia Pacific Customer Response Group**  
 Tel: 65-2544466  
 Fax: 65-2504466  
 Email: sea.support@nsc.com

**National Semiconductor Japan Ltd.**  
 Tel: 81-3-5639-7560  
 Fax: 81-3-5639-7507