

8-Bit Serial-Input/Serial or Parallel-Output Shift Register with Latched 3-State Outputs

High-Performance Silicon-Gate CMOS

The MC54/74HC595A is identical in pinout to the LS595. The device inputs are compatible with standard CMOS outputs; with pullup resistors, they are compatible with LSTTL outputs.

The HC595A consists of an 8-bit shift register and an 8-bit D-type latch with three-state parallel outputs. The shift register accepts serial data and provides a serial output. The shift register also provides parallel data to the 8-bit latch. The shift register and latch have independent clock inputs. This device also has an asynchronous reset for the shift register.

The HC595A directly interfaces with the Motorola SPI serial data port on CMOS MPUs and MCUs.

- Output Drive Capability: 15 LSTTL Loads
- Outputs Directly Interface to CMOS, NMOS, and TTL
- Operating Voltage Range: 2.0 to 6.0 V
- Low Input Current: 1.0 μ A
- High Noise Immunity Characteristic of CMOS Devices
- In Compliance with the Requirements Defined by JEDEC Standard No. 7A
- Chip Complexity: 328 FETs or 82 Equivalent Gates
- Improvements over HC595
 - Improved Propagation Delays
 - 50% Lower Quiescent Power
 - Improved Input Noise and Latchup Immunity

LOGIC DIAGRAM

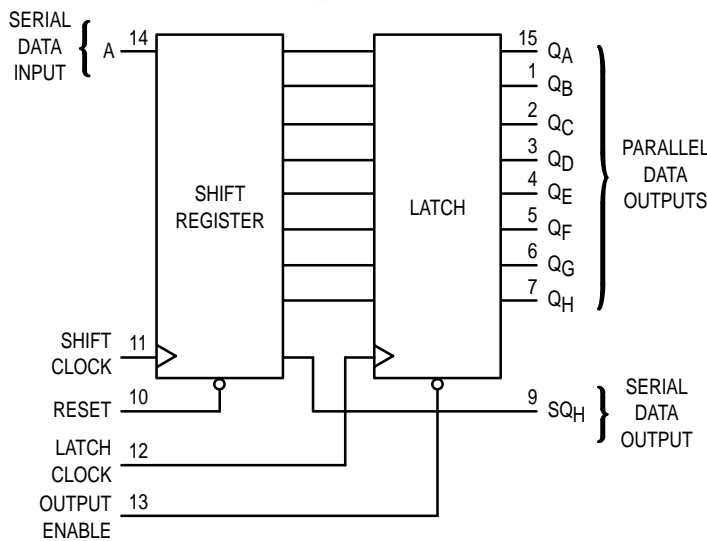

VCC = PIN 16
GND = PIN 8

MC54/74HC595A

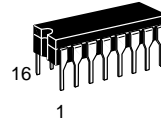

J SUFFIX
CERAMIC PACKAGE
CASE 620-10

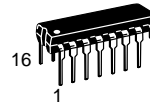

N SUFFIX
PLASTIC PACKAGE
CASE 648-08



D SUFFIX
SOIC PACKAGE
CASE 751B-05



DT SUFFIX
TSSOP PACKAGE
CASE 948F-01

ORDERING INFORMATION

| | |
|--------------|---------|
| MC54HCXXXAJ | Ceramic |
| MC74HCXXXAN | Plastic |
| MC74HCXXXAD | SOIC |
| MC74HCXXXADT | TSSOP |

PIN ASSIGNMENT

| | | | |
|-----|---|----|---------------|
| QB | 1 | 16 | VCC |
| QC | 2 | 15 | QA |
| QD | 3 | 14 | A |
| QE | 4 | 13 | OUTPUT ENABLE |
| QF | 5 | 12 | LATCH CLOCK |
| QG | 6 | 11 | SHIFT CLOCK |
| QH | 7 | 10 | RESET |
| GND | 8 | 9 | SQH |



MC54/74HC595A

MAXIMUM RATINGS*

| Symbol | Parameter | Value | Unit |
|------------------|--|--------------------------------|------|
| V _{CC} | DC Supply Voltage (Referenced to GND) | - 0.5 to + 7.0 | V |
| V _{in} | DC Input Voltage (Referenced to GND) | - 0.5 to V _{CC} + 0.5 | V |
| V _{out} | DC Output Voltage (Referenced to GND) | - 0.5 to V _{CC} + 0.5 | V |
| I _{in} | DC Input Current, per Pin | ± 20 | mA |
| I _{out} | DC Output Current, per Pin | ± 35 | mA |
| I _{CC} | DC Supply Current, V _{CC} and GND Pins | ± 75 | mA |
| P _D | Power Dissipation in Still Air, Plastic or Ceramic DIP† SOIC Package† TSSOP Package† | 750 500 450 | mW |
| T _{stg} | Storage Temperature | - 65 to + 150 | °C |
| T _L | Lead Temperature, 1 mm from Case for 10 Seconds (Plastic DIP, SOIC or TSSOP Package) (Ceramic DIP) | 260 300 | °C |

This device contains protection circuitry to guard against damage due to high static voltages or electric fields. However, precautions must be taken to avoid applications of any voltage higher than maximum rated voltages to this high-impedance circuit. For proper operation, V_{in} and V_{out} should be constrained to the range GND ≤ (V_{in} or V_{out}) ≤ V_{CC}. Unused inputs must always be tied to an appropriate logic voltage level (e.g., either GND or V_{CC}). Unused outputs must be left open.

* Maximum Ratings are those values beyond which damage to the device may occur. Functional operation should be restricted to the Recommended Operating Conditions.

† Derating — Plastic DIP: - 10 mW/°C from 65° to 125°C
Ceramic DIP: - 10 mW/°C from 100° to 125°C
SOIC Package: - 7 mW/°C from 65° to 125°C
TSSOP Package: - 6.1 mW/°C from 65° to 125°C

For high frequency or heavy load considerations, see Chapter 2 of the Motorola High-Speed CMOS Data Book (DL129/D).

RECOMMENDED OPERATING CONDITIONS

| Symbol | Parameter | Min | Max | Unit | |
|------------------------------------|--|---|-----------------|--------------------|----|
| V _{CC} | DC Supply Voltage (Referenced to GND) | 2.0 | 6.0 | V | |
| V _{in} , V _{out} | DC Input Voltage, Output Voltage (Referenced to GND) | 0 | V _{CC} | V | |
| T _A | Operating Temperature, All Package Types | - 55 | + 125 | °C | |
| t _r , t _f | Input Rise and Fall Time (Figure 1) | V _{CC} = 2.0 V V _{CC} = 4.5 V V _{CC} = 6.0 V | 0 0 0 | 1000 500 400 | ns |

DC ELECTRICAL CHARACTERISTICS (Voltages Referenced to GND)

| Symbol | Parameter | Test Conditions | V _{CC} V | Guaranteed Limit | | | Unit | |
|-----------------|--|---|--|------------------|--------|---------|------|-----|
| | | | | - 55 to 25°C | ≤ 85°C | ≤ 125°C | | |
| V _{IH} | Minimum High-Level Input Voltage | V _{out} = 0.1 V or V _{CC} - 0.1 V I _{out} ≤ 20 μA | 2.0 | 1.5 | 1.5 | 1.5 | V | |
| | | | 3.0 | 2.1 | 2.1 | 2.1 | | |
| | | | 4.5 | 3.15 | 3.15 | 3.15 | | |
| | | | 6.0 | 4.2 | 4.2 | 4.2 | | |
| V _{IL} | Maximum Low-Level Input Voltage | V _{out} = 0.1 V or V _{CC} - 0.1 V I _{out} ≤ 20 μA | 2.0 | 0.5 | 0.5 | 0.5 | V | |
| | | | 3.0 | 0.9 | 0.9 | 0.9 | | |
| | | | 4.5 | 1.35 | 1.35 | 1.35 | | |
| | | | 6.0 | 1.8 | 1.8 | 1.8 | | |
| V _{OH} | Minimum High-Level Output Voltage, Q _A - Q _H | V _{in} = V _{IH} or V _{IL} I _{out} ≤ 20 μA | 2.0 | 1.9 | 1.9 | 1.9 | V | |
| | | | 4.5 | 4.4 | 4.4 | 4.4 | | |
| | | | 6.0 | 5.9 | 5.9 | 5.9 | | |
| | | | V _{in} = V _{IH} or V _{IL} I _{out} ≤ 2.4 mA I _{out} ≤ 6.0 mA I _{out} ≤ 7.8 mA | 3.0 | 2.48 | 2.34 | | 2.2 |
| | | | | 4.5 | 3.98 | 3.84 | | 3.7 |
| | | | | 6.0 | 5.48 | 5.34 | | 5.2 |

DC ELECTRICAL CHARACTERISTICS (Voltages Referenced to GND)

| Symbol | Parameter | Test Conditions | V _{CC} V | Guaranteed Limit | | | Unit |
|-----------------|--|--|----------------------|------------------|--------|---------|------|
| | | | | - 55 to 25°C | ≤ 85°C | ≤ 125°C | |
| V _{OL} | Maximum Low-Level Output Voltage, Q _A – Q _H | V _{in} = V _{IH} or V _{IL} I _{out} ≤ 20 μA | 2.0 | 0.1 | 0.1 | 0.1 | V |
| | | | 4.5 | 0.1 | 0.1 | 0.1 | |
| | | | 6.0 | 0.1 | 0.1 | 0.1 | |
| | | V _{in} = V _{IH} or V _{IL} I _{out} ≤ 2.4 mA I _{out} ≤ 6.0 mA I _{out} ≤ 7.8 mA | 3.0 | 0.26 | 0.33 | 0.4 | |
| | | | 4.5 | 0.26 | 0.33 | 0.4 | |
| | | | 6.0 | 0.26 | 0.33 | 0.4 | |
| V _{OH} | Minimum High-Level Output Voltage, SQ _H | V _{in} = V _{IH} or V _{IL} I _{out} ≤ 20 μA | 2.0 | 1.9 | 1.9 | 1.9 | V |
| | | | 4.5 | 4.4 | 4.4 | 4.4 | |
| | | | 6.0 | 5.9 | 5.9 | 5.9 | |
| | | V _{in} = V _{IH} or V _{IL} I _{out} ≤ 2.4 mA I _{out} ≤ 4.0 mA I _{out} ≤ 5.2 mA | 3.0 | 2.98 | 2.34 | 2.2 | |
| | | | 4.5 | 3.98 | 3.84 | 3.7 | |
| | | | 6.0 | 5.48 | 5.34 | 5.2 | |
| V _{OL} | Maximum Low-Level Output Voltage, SQ _H | V _{in} = V _{IH} or V _{IL} I _{out} ≤ 20 μA | 2.0 | 0.1 | 0.1 | 0.1 | V |
| | | | 4.5 | 0.1 | 0.1 | 0.1 | |
| | | | 6.0 | 0.1 | 0.1 | 0.1 | |
| | | V _{in} = V _{IH} or V _{IL} I _{out} ≤ 2.4 mA I _{out} ≤ 4.0 mA I _{out} ≤ 5.2 mA | 3.0 | 0.26 | 0.33 | 0.4 | |
| | | | 4.5 | 0.26 | 0.33 | 0.4 | |
| | | | 6.0 | 0.26 | 0.33 | 0.4 | |
| I _{in} | Maximum Input Leakage Current | V _{in} = V _{CC} or GND | 6.0 | ± 0.1 | ± 1.0 | ± 1.0 | μA |
| I _{OZ} | Maximum Three-State Leakage Current, Q _A – Q _H | Output in High-Impedance State V _{in} = V _{IL} or V _{IH} V _{out} = V _{CC} or GND | 6.0 | ± 0.5 | ± 5.0 | ± 10 | μA |
| I _{CC} | Maximum Quiescent Supply Current (per Package) | V _{in} = V _{CC} or GND I _{out} = 0 μA | 6.0 | 4.0 | 40 | 160 | μA |

NOTE: Information on typical parametric values can be found in Chapter 2 of the Motorola High-Speed CMOS Data Book (DL129/D).

AC ELECTRICAL CHARACTERISTICS (C_L = 50 pF, Input t_r = t_f = 6.0 ns)

| Symbol | Parameter | V _{CC} V | Guaranteed Limit | | | Unit |
|--|--|----------------------|------------------|--------|---------|------|
| | | | - 55 to 25°C | ≤ 85°C | ≤ 125°C | |
| f _{max} | Maximum Clock Frequency (50% Duty Cycle) (Figures 1 and 7) | 2.0 | 6.0 | 4.8 | 4.0 | MHz |
| | | 3.0 | 15 | 10 | 8.0 | |
| | | 4.5 | 30 | 24 | 20 | |
| | | 6.0 | 35 | 28 | 24 | |
| t _{PLH} , t _{PHL} | Maximum Propagation Delay, Shift Clock to SQ _H (Figures 1 and 7) | 2.0 | 140 | 175 | 210 | ns |
| | | 3.0 | 100 | 125 | 150 | |
| | | 4.5 | 28 | 35 | 42 | |
| | | 6.0 | 24 | 30 | 36 | |
| t _{PHL} | Maximum Propagation Delay, Reset to SQ _H (Figures 2 and 7) | 2.0 | 145 | 180 | 220 | ns |
| | | 3.0 | 100 | 125 | 150 | |
| | | 4.5 | 29 | 36 | 44 | |
| | | 6.0 | 25 | 31 | 38 | |
| t _{PLH} , t _{PHL} | Maximum Propagation Delay, Latch Clock to Q _A – Q _H (Figures 3 and 7) | 2.0 | 140 | 175 | 210 | ns |
| | | 3.0 | 100 | 125 | 150 | |
| | | 4.5 | 28 | 35 | 42 | |
| | | 6.0 | 24 | 30 | 36 | |
| t _{PLZ} , t _{PHZ} | Maximum Propagation Delay, Output Enable to Q _A – Q _H (Figures 4 and 8) | 2.0 | 150 | 190 | 225 | ns |
| | | 3.0 | 100 | 125 | 150 | |
| | | 4.5 | 30 | 38 | 45 | |
| | | 6.0 | 26 | 33 | 38 | |
| t _{PZL} , t _{PZH} | Maximum Propagation Delay, Output Enable to Q _A – Q _H (Figures 4 and 8) | 2.0 | 135 | 170 | 205 | ns |
| | | 3.0 | 90 | 110 | 130 | |
| | | 4.5 | 27 | 34 | 41 | |
| | | 6.0 | 23 | 29 | 35 | |

MC54/74HC595A

AC ELECTRICAL CHARACTERISTICS (C_L = 50 pF, Input t_r = t_f = 6.0 ns)

| Symbol | Parameter | V _{CC} V | Guaranteed Limit | | | Unit |
|--|--|----------------------|------------------|--------|---------|------|
| | | | - 55 to 25°C | ≤ 85°C | ≤ 125°C | |
| t _{TLH} , t _{THL} | Maximum Output Transition Time, Q _A – Q _H (Figures 3 and 7) | 2.0 | 60 | 75 | 90 | ns |
| | | 3.0 | 23 | 27 | 31 | |
| | | 4.5 | 12 | 15 | 18 | |
| | | 6.0 | 10 | 13 | 15 | |
| t _{TLH} , t _{THL} | Maximum Output Transition Time, SQ _H (Figures 1 and 7) | 2.0 | 75 | 95 | 110 | ns |
| | | 3.0 | 27 | 32 | 36 | |
| | | 4.5 | 15 | 19 | 22 | |
| | | 6.0 | 13 | 16 | 19 | |
| C _{in} | Maximum Input Capacitance | — | 10 | 10 | 10 | pF |
| C _{out} | Maximum Three-State Output Capacitance (Output in High-Impedance State), Q _A – Q _H | — | 15 | 15 | 15 | pF |

NOTE: For propagation delays with loads other than 50 pF, and information on typical parametric values, see Chapter 2 of the Motorola High-Speed CMOS Data Book (DL129/D).

| C _{PD} | Power Dissipation Capacitance (Per Package)* | Typical @ 25°C, V _{CC} = 5.0 V | | pF |
|-----------------|--|---|--|----|
| | | 300 | | |
| | | | | |

* Used to determine the no-load dynamic power consumption: P_D = C_{PD} V_{CC}²f + I_{CC} V_{CC}. For load considerations, see Chapter 2 of the Motorola High-Speed CMOS Data Book (DL129/D).

TIMING REQUIREMENTS (Input t_r = t_f = 6.0 ns)

| Symbol | Parameter | V _{CC} V | Guaranteed Limit | | | Unit |
|---------------------------------|--|----------------------|-------------------|--------|---------|------|
| | | | 25°C to - 55°C | ≤ 85°C | ≤ 125°C | |
| t _{su} | Minimum Setup Time, Serial Data Input A to Shift Clock (Figure 5) | 2.0 | 50 | 65 | 75 | ns |
| | | 3.0 | 40 | 50 | 60 | |
| | | 4.5 | 10 | 13 | 15 | |
| | | 6.0 | 9.0 | 11 | 13 | |
| t _{su} | Minimum Setup Time, Shift Clock to Latch Clock (Figure 6) | 2.0 | 75 | 95 | 110 | ns |
| | | 3.0 | 60 | 70 | 80 | |
| | | 4.5 | 15 | 19 | 22 | |
| | | 6.0 | 13 | 16 | 19 | |
| t _h | Minimum Hold Time, Shift Clock to Serial Data Input A (Figure 5) | 2.0 | 5.0 | 5.0 | 5.0 | ns |
| | | 3.0 | 5.0 | 5.0 | 5.0 | |
| | | 4.5 | 5.0 | 5.0 | 5.0 | |
| | | 6.0 | 5.0 | 5.0 | 5.0 | |
| t _{rec} | Minimum Recovery Time, Reset Inactive to Shift Clock (Figure 2) | 2.0 | 50 | 65 | 75 | ns |
| | | 3.0 | 40 | 50 | 60 | |
| | | 4.5 | 10 | 13 | 15 | |
| | | 6.0 | 9.0 | 11 | 13 | |
| t _w | Minimum Pulse Width, Reset (Figure 2) | 2.0 | 60 | 75 | 90 | ns |
| | | 3.0 | 45 | 60 | 70 | |
| | | 4.5 | 12 | 15 | 18 | |
| | | 6.0 | 10 | 13 | 15 | |
| t _w | Minimum Pulse Width, Shift Clock (Figure 1) | 2.0 | 50 | 65 | 75 | ns |
| | | 3.0 | 40 | 50 | 60 | |
| | | 4.5 | 10 | 13 | 15 | |
| | | 6.0 | 9.0 | 11 | 13 | |
| t _w | Minimum Pulse Width, Latch Clock (Figure 6) | 2.0 | 50 | 65 | 75 | ns |
| | | 3.0 | 40 | 50 | 60 | |
| | | 4.5 | 10 | 13 | 15 | |
| | | 6.0 | 9.0 | 11 | 13 | |
| t _r , t _f | Maximum Input Rise and Fall Times (Figure 1) | 2.0 | 1000 | 1000 | 1000 | ns |
| | | 3.0 | 800 | 800 | 800 | |
| | | 4.5 | 500 | 500 | 500 | |
| | | 6.0 | 400 | 400 | 400 | |

FUNCTION TABLE

| Operation | Inputs | | | | | Resulting Function | | | |
|--|--------|----------------|-------------|-------------|---------------|--|-----------------------------------|-----------------------------------|--|
| | Reset | Serial Input A | Shift Clock | Latch Clock | Output Enable | Shift Register Contents | Latch Register Contents | Serial Output SQ _H | Parallel Outputs Q _A – Q _H |
| Reset shift register | L | X | X | L, H, ↓ | L | L | U | L | U |
| Shift data into shift register | H | D | ↑ | L, H, ↓ | L | D → SR _A ; SR _N → SR _{N+1} | U | SR _G → SR _H | U |
| Shift register remains unchanged | H | X | L, H, ↓ | L, H, ↓ | L | U | U | U | U |
| Transfer shift register contents to latch register | H | X | L, H, ↓ | ↑ | L | U | SR _N → LR _N | U | SR _N |
| Latch register remains unchanged | X | X | X | L, H, ↓ | L | * | U | * | U |
| Enable parallel outputs | X | X | X | X | L | * | ** | * | Enabled |
| Force outputs into high impedance state | X | X | X | X | H | * | ** | * | Z |

SR = shift register contents
LR = latch register contents

D = data (L, H) logic level
U = remains unchanged

↑ = Low-to-High
↓ = High-to-Low

* = depends on Reset and Shift Clock inputs
** = depends on Latch Clock input

PIN DESCRIPTIONS

INPUTS

A (Pin 14)

Serial Data Input. The data on this pin is shifted into the 8-bit serial shift register.

CONTROL INPUTS

Shift Clock (Pin 11)

Shift Register Clock Input. A low-to-high transition on this input causes the data at the Serial Input pin to be shifted into the 8-bit shift register.

Reset (Pin 10)

Active-low, Asynchronous, Shift Register Reset Input. A low on this pin resets the shift register portion of this device only. The 8-bit latch is not affected.

Latch Clock (Pin 12)

Storage Latch Clock Input. A low-to-high transition on this input latches the shift register data.

Output Enable (Pin 13)

Active-low Output Enable. A low on this input allows the data from the latches to be presented at the outputs. A high on this input forces the outputs (Q_A–Q_H) into the high-impedance state. The serial output is not affected by this control unit.

OUTPUTS

Q_A – Q_H (Pins 15, 1, 2, 3, 4, 5, 6, 7)

Noninverted, 3-state, latch outputs.

SQ_H (Pin 9)

Noninverted, Serial Data Output. This is the output of the eighth stage of the 8-bit shift register. This output does not have three-state capability.

SWITCHING WAVEFORMS

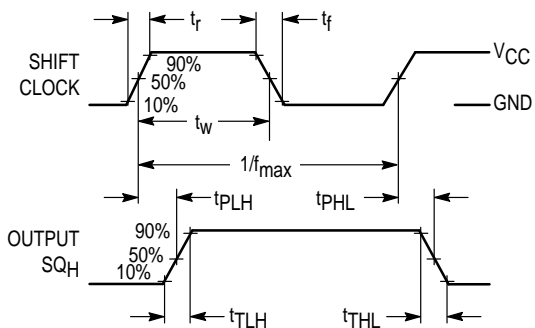

Figure 1.

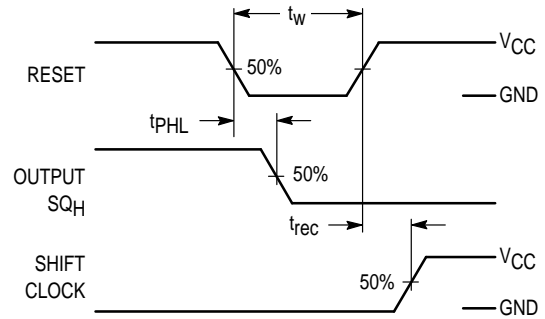

Figure 2.

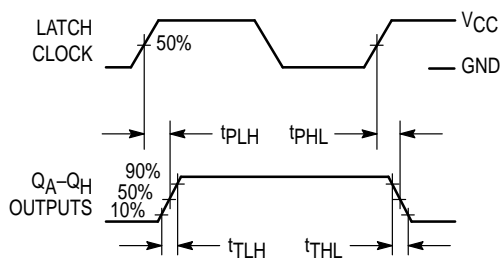

Figure 3.

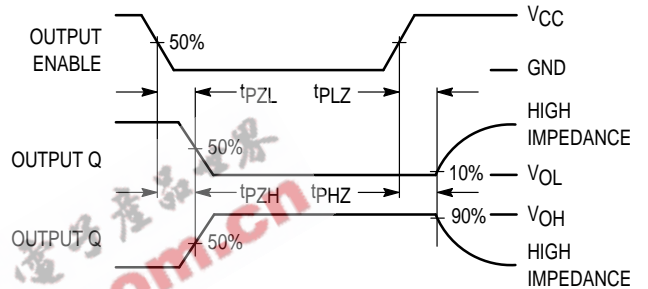

Figure 4.

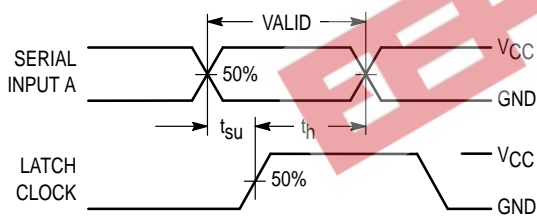

Figure 5.

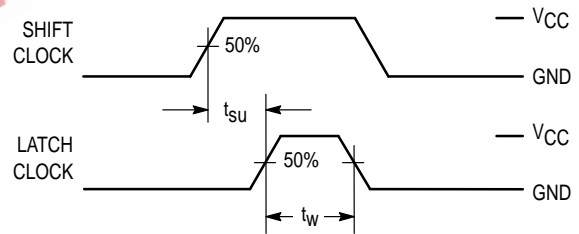
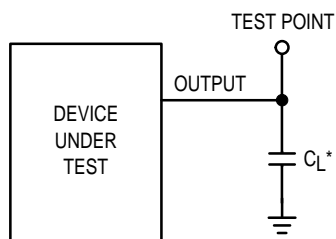

Figure 6.

TEST CIRCUITS



* Includes all probe and jig capacitance

Figure 7.

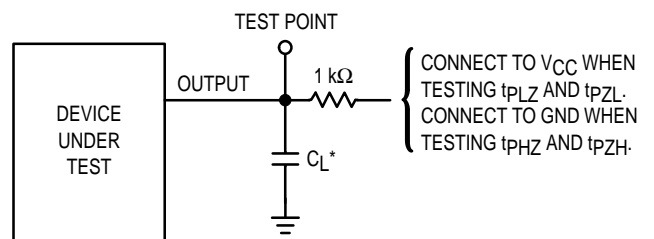

* Includes all probe and jig capacitance

Figure 8.

EXPANDED LOGIC DIAGRAM

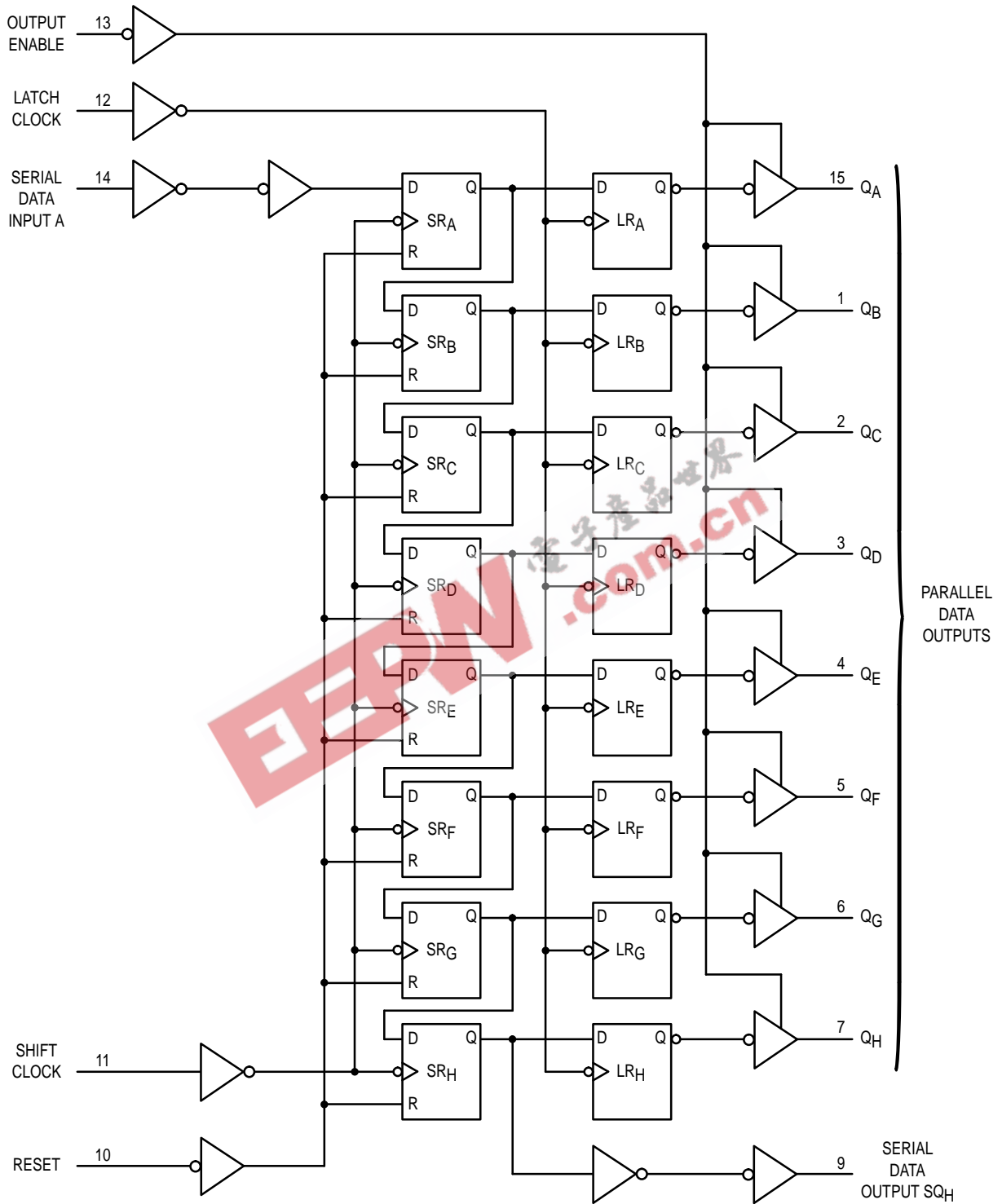

MC54/74HC595A

TIMING DIAGRAM

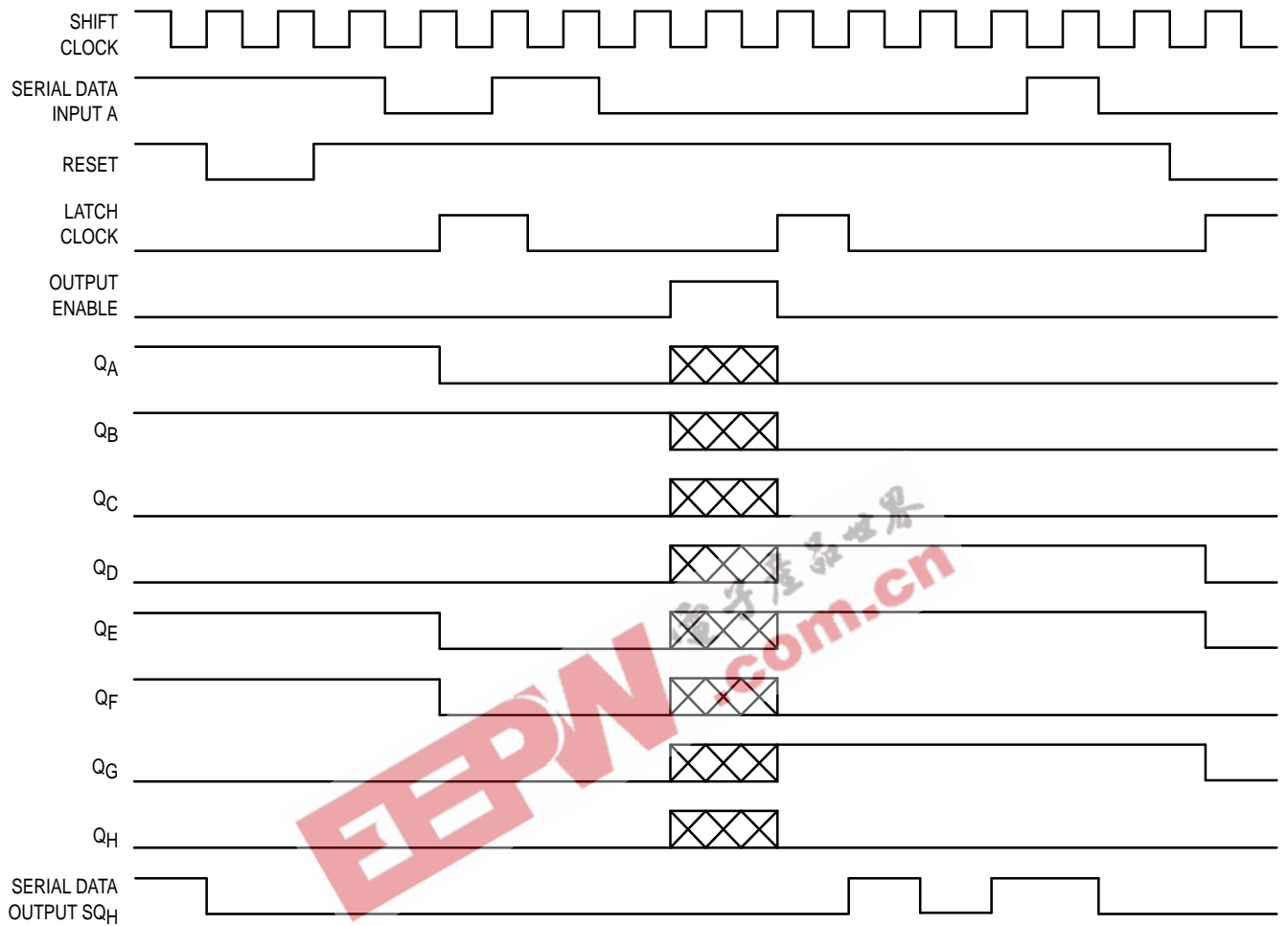

NOTE:  implies that the output is in a high-impedance state.

OUTLINE DIMENSIONS

J SUFFIX
CERAMIC PACKAGE
CASE 620-10
ISSUE V

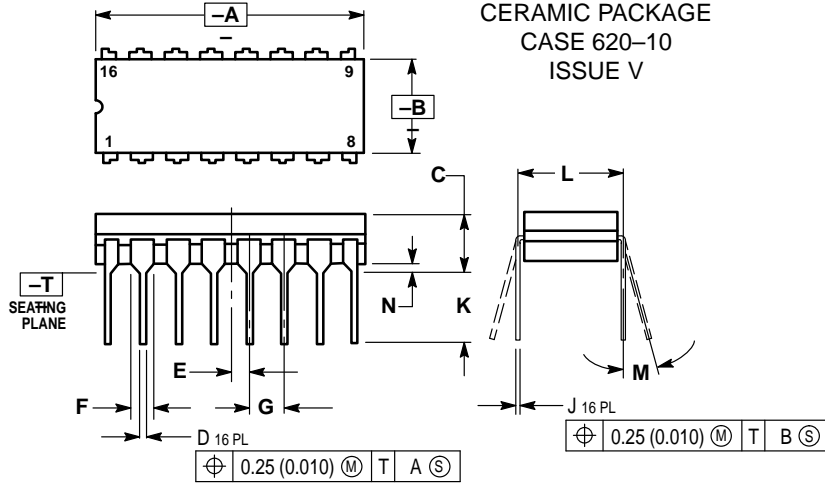

- NOTES:
1. DIMENSIONING AND TOLERANCING PER ANSI Y14.5M, 1982.
 2. CONTROLLING DIMENSION: INCH.
 3. DIMENSION L TO CENTER OF LEAD WHEN FORMED PARALLEL.
 4. DIM F MAY NARROW TO 0.76 (0.030) WHERE THE LEAD ENTERS THE CERAMIC BODY.

| DIM | INCHES | | MILLIMETERS | |
|-----|-----------|-------|-------------|-------|
| | MIN | MAX | MIN | MAX |
| A | 0.750 | 0.785 | 19.05 | 19.93 |
| B | 0.240 | 0.295 | 6.10 | 7.49 |
| C | — | 0.200 | — | 5.08 |
| D | 0.015 | 0.020 | 0.39 | 0.50 |
| E | 0.050 BSC | | 1.27 BSC | |
| F | 0.055 | 0.065 | 1.40 | 1.65 |
| G | 0.100 BSC | | 2.54 BSC | |
| J | 0.008 | 0.015 | 0.21 | 0.38 |
| K | 0.125 | 0.170 | 3.18 | 4.31 |
| L | 0.300 BSC | | 7.62 BSC | |
| M | 0° | 15° | 0° | 15° |
| N | 0.020 | 0.040 | 0.51 | 1.01 |

N SUFFIX
PLASTIC PACKAGE
CASE 648-08
ISSUE R

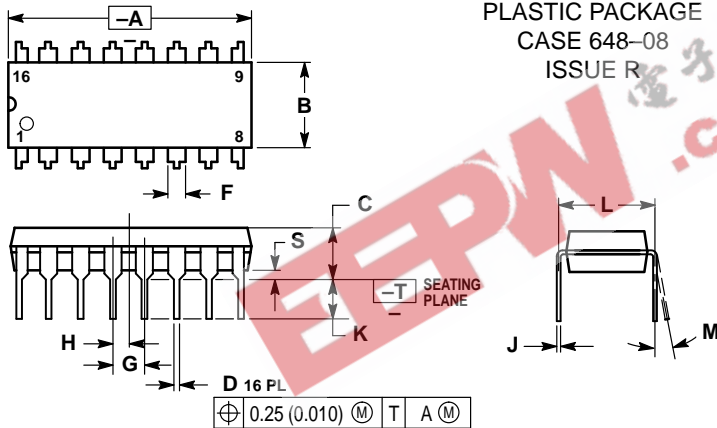

- NOTES:
1. DIMENSIONING AND TOLERANCING PER ANSI Y14.5M, 1982.
 2. CONTROLLING DIMENSION: INCH.
 3. DIMENSION L TO CENTER OF LEAD WHEN FORMED PARALLEL.
 4. DIMENSION B DOES NOT INCLUDE MOLD FLASH.
 5. ROUNDED CORNERS OPTIONAL.

| DIM | INCHES | | MILLIMETERS | |
|-----|-----------|-------|-------------|-------|
| | MIN | MAX | MIN | MAX |
| A | 0.740 | 0.770 | 18.80 | 19.55 |
| B | 0.250 | 0.270 | 6.35 | 6.85 |
| C | 0.145 | 0.175 | 3.69 | 4.44 |
| D | 0.015 | 0.021 | 0.39 | 0.53 |
| F | 0.040 | 0.070 | 1.02 | 1.77 |
| G | 0.100 BSC | | 2.54 BSC | |
| H | 0.050 BSC | | 1.27 BSC | |
| J | 0.008 | 0.015 | 0.21 | 0.38 |
| K | 0.110 | 0.130 | 2.80 | 3.30 |
| L | 0.295 | 0.305 | 7.50 | 7.74 |
| M | 0° | 10° | 0° | 10° |
| S | 0.020 | 0.040 | 0.51 | 1.01 |

D SUFFIX
PLASTIC SOIC PACKAGE
CASE 751B-05
ISSUE J

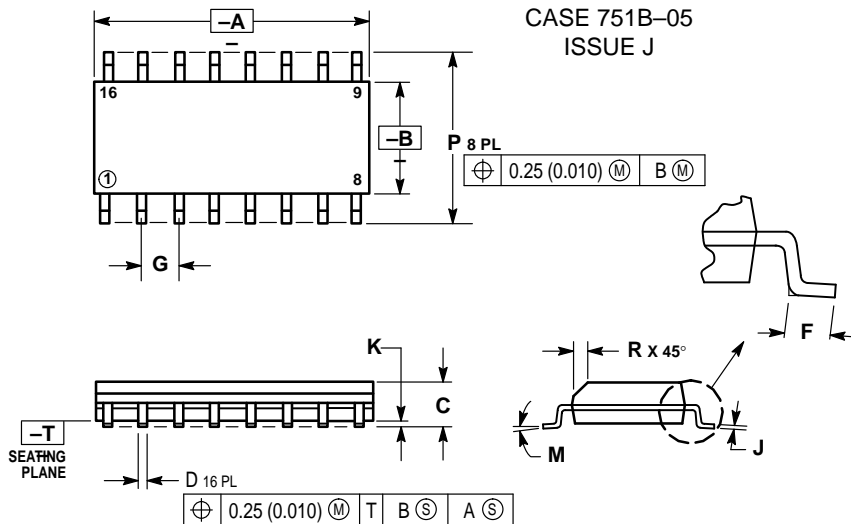

- NOTES:
1. DIMENSIONING AND TOLERANCING PER ANSI Y14.5M, 1982.
 2. CONTROLLING DIMENSION: MILLIMETER.
 3. DIMENSIONS A AND B DO NOT INCLUDE MOLD PROTRUSION.
 4. MAXIMUM MOLD PROTRUSION 0.15 (0.006) PER SIDE.
 5. DIMENSION D DOES NOT INCLUDE DAMBAR PROTRUSION. ALLOWABLE DAMBAR PROTRUSION SHALL BE 0.127 (0.005) TOTAL IN EXCESS OF THE D DIMENSION AT MAXIMUM MATERIAL CONDITION.

| DIM | MILLIMETERS | | INCHES | |
|-----|-------------|-------|-----------|-------|
| | MIN | MAX | MIN | MAX |
| A | 9.80 | 10.00 | 0.386 | 0.393 |
| B | 3.80 | 4.00 | 0.150 | 0.157 |
| C | 1.35 | 1.75 | 0.054 | 0.068 |
| D | 0.35 | 0.49 | 0.014 | 0.019 |
| F | 0.40 | 1.25 | 0.016 | 0.049 |
| G | 1.27 BSC | | 0.050 BSC | |
| J | 0.19 | 0.25 | 0.008 | 0.009 |
| K | 0.10 | 0.25 | 0.004 | 0.009 |
| M | 0° | 7° | 0° | 7° |
| P | 5.80 | 6.20 | 0.229 | 0.244 |
| R | 0.25 | 0.50 | 0.010 | 0.019 |

OUTLINE DIMENSIONS

DT SUFFIX
 PLASTIC TSSOP PACKAGE
 CASE 948F-01
 ISSUE O

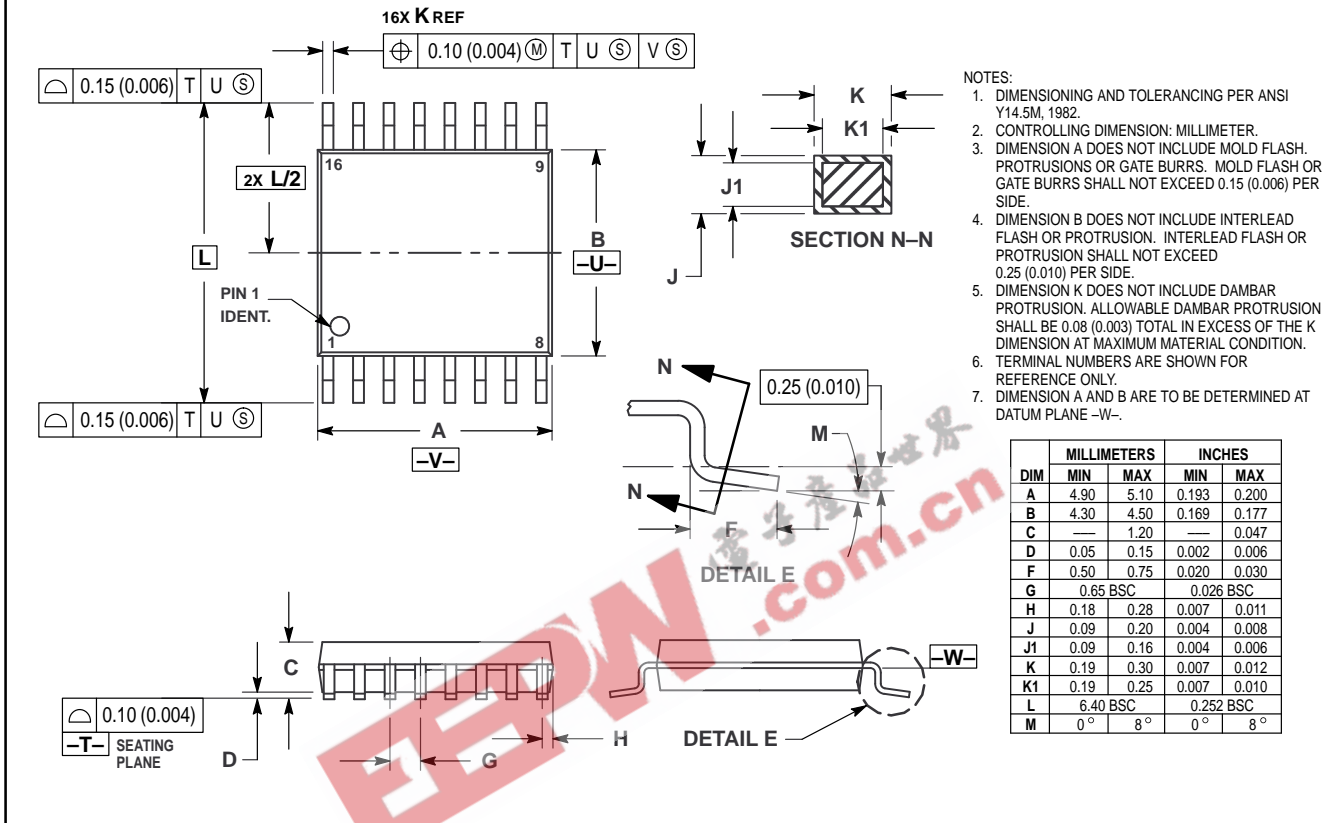

Motorola reserves the right to make changes without further notice to any products herein. Motorola makes no warranty, representation or guarantee regarding the suitability of its products for any particular purpose, nor does Motorola assume any liability arising out of the application or use of any product or circuit, and specifically disclaims any and all liability, including without limitation consequential or incidental damages. "Typical" parameters which may be provided in Motorola data sheets and/or specifications can and do vary in different applications and actual performance may vary over time. All operating parameters, including "Typicals" must be validated for each customer application by customer's technical experts. Motorola does not convey any license under its patent rights nor the rights of others. Motorola products are not designed, intended, or authorized for use as components in systems intended for surgical implant into the body, or other applications intended to support or sustain life, or for any other application in which the failure of the Motorola product could create a situation where personal injury or death may occur. Should Buyer purchase or use Motorola products for any such unintended or unauthorized application, Buyer shall indemnify and hold Motorola and its officers, employees, subsidiaries, affiliates, and distributors harmless against all claims, costs, damages, and expenses, and reasonable attorney fees arising out of, directly or indirectly, any claim of personal injury or death associated with such unintended or unauthorized use, even if such claim alleges that Motorola was negligent regarding the design or manufacture of the part. Motorola and M are registered trademarks of Motorola, Inc. Motorola, Inc. is an Equal Opportunity/Affirmative Action Employer.

Mfax is a trademark of Motorola, Inc.

How to reach us:
USA/EUROPE/Locations Not Listed: Motorola Literature Distribution;
 P.O. Box 5405, Denver, Colorado 80217. 303-675-2140 or 1-800-441-2447

JAPAN: Nippon Motorola Ltd.; Tatsumi-SPD-JLDC, 6F Seibu-Butsuryu-Center,
 3-14-2 Tatsumi Koto-Ku, Tokyo 135, Japan. 81-3-3521-8315

Mfax™: RMFAX0@email.sps.mot.com – TOUCHTONE 602-244-6609
 – US & Canada ONLY 1-800-774-1848

ASIA/PACIFIC: Motorola Semiconductors H.K. Ltd.; 8B Tai Ping Industrial Park,
 51 Ting Kok Road, Tai Po, N.T., Hong Kong. 852-26629298

INTERNET: http://www.mot.com/SPS/

