

## LM137HV/LM337HV 3-Terminal Adjustable Negative Regulators (High Voltage)

### General Description

The LM137HV/LM337HV are adjustable 3-terminal negative voltage regulators capable of supplying in excess of  $-1.5A$  over an output voltage range of  $-1.2V$  to  $-47V$ . These regulators are exceptionally easy to apply, requiring only 2 external resistors to set the output voltage and 1 output capacitor for frequency compensation. The circuit design has been optimized for excellent regulation and low thermal transients. Further, the LM137HV series features internal current limiting, thermal shutdown and safe-area compensation, making them virtually blowout-proof against overloads.

The LM137HV/LM337HV serve a wide variety of applications including local on-card regulation, programmable-output voltage regulation or precision current regulation. The LM137HV/LM337HV are ideal complements to the LM117HV/LM317HV adjustable positive regulators.

### Features

- Output voltage adjustable from  $-1.2V$  to  $-47V$
- $1.5A$  output current guaranteed,  $-55^{\circ}C$  to  $+150^{\circ}C$
- Line regulation typically  $0.01\%/V$
- Load regulation typically  $0.3\%$
- Excellent thermal regulation,  $0.002\%/W$
- $77$  dB ripple rejection
- Excellent rejection of thermal transients
- $50$  ppm/ $^{\circ}C$  temperature coefficient
- Temperature-independent current limit
- Internal thermal overload protection
- P\* Product Enhancement tested
- Standard 3-lead transistor package
- Output short circuit protected

### Typical Applications

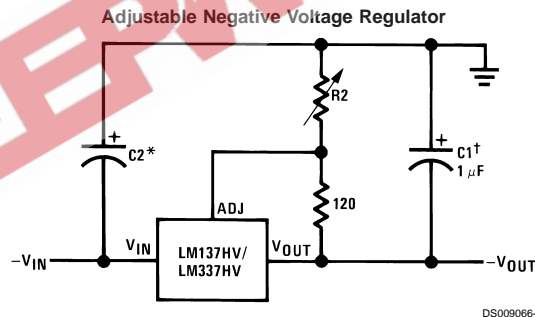

$$-V_{OUT} = -1.25V \left( 1 + \frac{R_2}{120\Omega} \right) + \left[ -I_{Adj}(R_2) \right]$$

DS009066-25

†C1 =  $1 \mu F$  solid tantalum or  $10 \mu F$  aluminum electrolytic required for stability. Output capacitors in the range of  $1 \mu F$  to  $1000 \mu F$  of aluminum or tantalum electrolytic are commonly used to provide improved output impedance and rejection of transients.

\*C2 =  $1 \mu F$  solid tantalum is required only if regulator is more than  $4''$  from power-supply filter capacitor.

## Absolute Maximum Ratings (Note 1)

If Military/Aerospace specified devices are required, please contact the National Semiconductor Sales Office/Distributors for availability and specifications.

(Note 4)

Power Dissipation Internally limited  
Input — Output Voltage Differential 50V

Operating Junction Temperature Range

LM137HV -55°C to +150°C

LM337HV 0°C to +125°C

Storage Temperature

-65°C to +150°C

Lead Temperature

(Soldering, 10 sec.)

300°

ESD rating is to be determined.

## Electrical Characteristics (Note 2)

Parameter	Conditions	LM137HV			LM337HV			Units
		Min	Typ	Max	Min	Typ	Max	
Line Regulation	$T_J = 25^\circ\text{C}$ , $3\text{V} \leq  V_{IN} - V_{OUT}  \leq 50\text{V}$ , (Note 3) $I_L = 10\text{ mA}$		0.01	0.02		0.01	0.04	%/V
Load Regulation	$T_J = 25^\circ\text{C}$ , $10\text{ mA} \leq I_{OUT} \leq I_{MAX}$		0.3	0.5		0.3	1.0	%
Thermal Regulation	$T_J = 25^\circ\text{C}$ , 10 ms Pulse		0.002	0.02		0.003	0.04	%/W
Adjustment Pin Current			65	100		65	100	$\mu\text{A}$
Adjustment Pin Current Change	$10\text{ mA} \leq I_L \leq I_{MAX}$ $3.0\text{V} \leq  V_{IN} - V_{OUT}  \leq 50\text{V}$ , $T_J = 25^\circ$		2	5		2	5	$\mu\text{A}$
			4	6		3	6	$\mu\text{A}$
Reference Voltage	$T_J = 25^\circ\text{C}$ , (Note 4) $3\text{V} \leq  V_{IN} - V_{OUT}  \leq 50\text{V}$ , (Note 4) $10\text{ mA} \leq I_{OUT} \leq I_{MAX}$ , $P \leq P_{MAX}$	-1.225	-1.250	-1.275	-1.213	-1.250	-1.287	V
		-1.200	-1.250	-1.300	-1.200	-1.250	-1.300	V
Line Regulation	$3\text{V} \leq  V_{IN} - V_{OUT}  \leq 50\text{V}$ , (Note 3) $I_L = 10\text{ mA}$		0.02	0.05		0.02	0.07	%/V
Load Regulation	$10\text{ mA} \leq I_{OUT} \leq I_{MAX}$ , (Note 3)		0.3	1		0.3	1.5	%
Temperature Stability	$T_{MIN} \leq T_J \leq T_{MAX}$		0.6			0.6		%
Minimum Load Current	$ V_{IN} - V_{OUT}  \leq 50\text{V}$ $ V_{IN} - V_{OUT}  \leq 10\text{V}$		2.5	5		2.5	10	mA
			1.2	3		1.5	6	mA
Current Limit	$ V_{IN} - V_{OUT}  \leq 13\text{V}$ K Package H Package $ V_{IN} - V_{OUT}  = 50\text{V}$ K Package H Package	1.5	2.2	3.2	1.5	2.2	3.5	A
		0.5	0.8	1.6	0.5	0.8	1.8	A
		0.2	0.4	0.8	0.1	0.4	0.8	A
		0.1	0.17	0.5	0.050	0.17	0.5	A
RMS Output Noise, % of $V_{OUT}$	$T_J = 25^\circ\text{C}$ , $10\text{ Hz} \leq f \leq 10\text{ kHz}$		0.003			0.003		%
Ripple Rejection Ratio	$V_{OUT} = -10\text{V}$ , $f = 120\text{ Hz}$ $C_{ADJ} = 10\text{ }\mu\text{F}$		60			60		dB
		66	77		66	77		dB
Long-Term Stability	$T_A = 125^\circ\text{C}$ , 1000 Hours		0.3	1		0.3	1	%
Thermal Resistance, Junction to Case	H Package		12	15		12	15	$^\circ\text{C/W}$
	K Package		2.3	3		2.3	3	$^\circ\text{C/W}$
Thermal Resistance, Junction to Ambient	H Package		140			140		$^\circ\text{C/W}$
	K Package		35			35		$^\circ\text{C/W}$

**Note 1:** "Absolute Maximum Ratings" indicate limits beyond which damage to the device may occur. Operating Ratings indicate conditions for which the device is functional, but do not guarantee specific performance limits.

**Note 2:** Unless otherwise specified, these specifications apply:  $-55^\circ\text{C} \leq T_J \leq +150^\circ\text{C}$  for the LM137HV,  $0^\circ\text{C} \leq T_J \leq +125^\circ\text{C}$  for the LM337HV;  $V_{IN} - V_{OUT} = 5\text{V}$ ; and  $I_{OUT} = 0.1\text{A}$  for the TO-39 package and  $I_{OUT} = 0.5\text{A}$  for the TO-3 package. Although power dissipation is internally limited, these specifications are applicable for power dissipations of 2W for the TO-39 and 20W for the TO-3.  $I_{MAX}$  is 1.5A for the TO-3 package and 0.2A for the TO-39 package.

**Note 3:** Regulation is measured at constant junction temperature, using pulse testing with a low duty cycle. Changes in output voltage due to heating effects are covered under the specification for thermal regulations. Load regulation is measured on the output pin at a point  $\frac{1}{8}$ " below the base of the TO-3 and TO-39 packages.

**Note 4:** Refer to RETS137HVH drawing for LM137HVH or RETS137HVK for LM137HVK military specifications.

Electrical Characteristics (Note 2) (Continued)

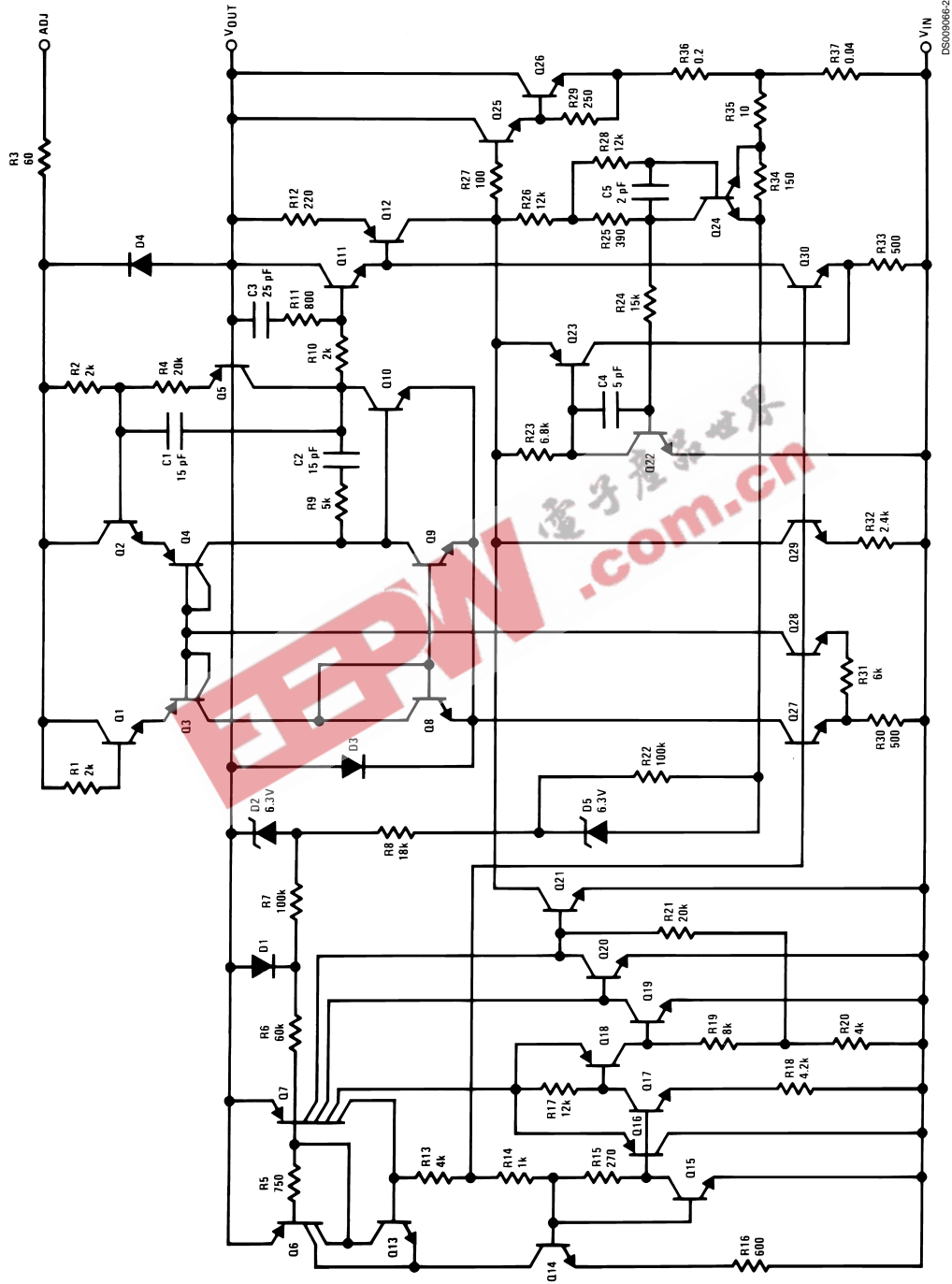

DSU09086-2

## Thermal Regulation

When power is dissipated in an IC, a temperature gradient occurs across the IC chip affecting the individual IC circuit components. With an IC regulator, this gradient can be especially severe since power dissipation is large. Thermal regulation is the effect of these temperature gradients on output voltage (in percentage output change) per Watt of power change in a specified time. Thermal regulation error is independent of electrical regulation or temperature coefficient, and occurs within 5 ms to 50 ms after a change in power dissipation. Thermal regulation depends on IC layout as well as electrical design. The thermal regulation of a voltage regulator is defined as the percentage change of  $V_{OUT}$ , per Watt, within the first 10 ms after a step of power is applied. The LM137HV's specification is 0.02%/W, max.

In *Figure 1*, a typical LM137HV's output drifts only 3 mV (or 0.03% of  $V_{OUT} = -10V$ ) when a 10W pulse is applied for 10 ms. This performance is thus well inside the specification limit of  $0.02\%/W \times 10W = 0.2\%$  max. When the 10W pulse is ended, the thermal regulation again shows a 3 mV step as the LM137HV chip cools off. Note that the load regulation error of about 8 mV (0.08%) is additional to the thermal regulation error. In *Figure 2*, when the 10W pulse is applied for 100 ms, the output drifts only slightly beyond the drift in the first 10 ms, and the thermal error stays well within 0.1% (10 mV).

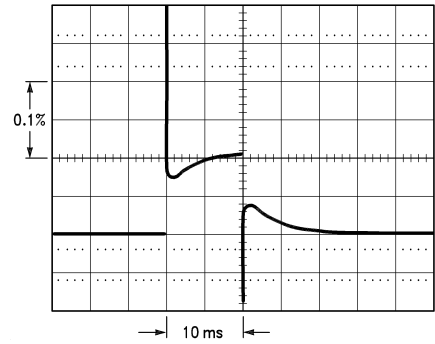

LM137HV,  $V_{OUT} = -10V$   
 $V_{IN} - V_{OUT} = -40V$   
 $I_L = 0A \rightarrow 0.25A \rightarrow 0A$   
 Vertical sensitivity, 5 mV/div

FIGURE 1.

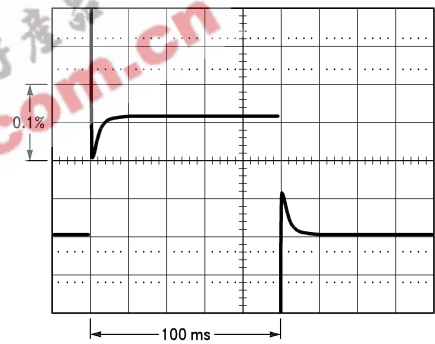

LM137HV,  $V_{OUT} = -10V$   
 $V_{IN} - V_{OUT} = -40V$   
 $I_L = 0A \rightarrow 0.25A \rightarrow 0A$   
 Horizontal sensitivity, 20 ms/div

FIGURE 2.

## Connection Diagram See Physical Dimensions section for further information)

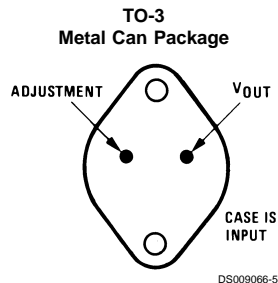

Bottom View  
 Order Number LM137HVH/883, LM137HVH-QMLV, or  
 SMD #7703404  
 See NS Package Number K02C  
 Order Number LM337HVH STEEL  
 See NS Package Number K02A

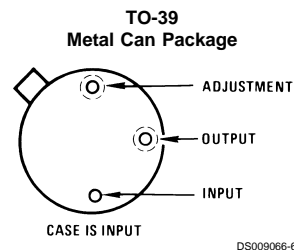

Bottom View  
 Order Number LM137HVH/883, LM137HVH-QMLV, SMD  
 #7703404  
 or LML337HVH  
 See NS Package Number H03A

## Typical Applications

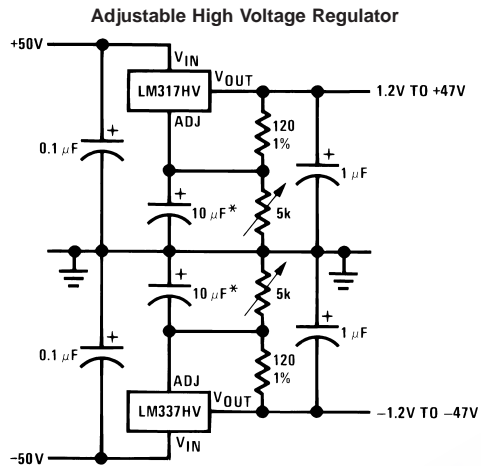

Full output current not available at high input-output voltages  
 \*The 10 μF capacitors are optional to improve ripple rejection

**Current Regulator**

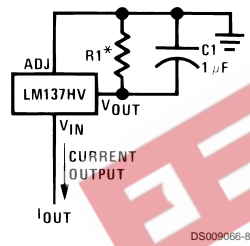

$$I_{OUT} = \frac{V_{REF}}{R1}$$

\*  $0.8\Omega \leq R1 \leq 120\Omega$

**Adjustable Current Regulator**

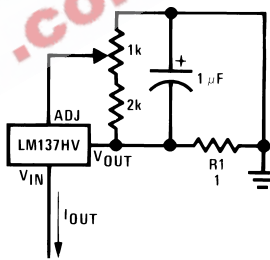

$$I_{OUT} = \left( \frac{1.5V}{R1} \right) \pm 15\% \text{ adjustable}$$

**Negative Regulator with Protection Diodes**

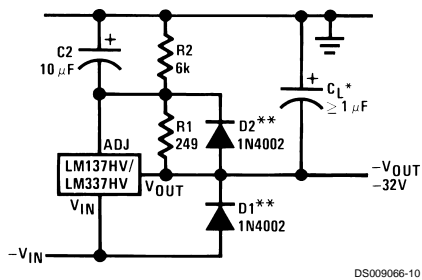

\*When  $C_L$  is larger than 20 μF, D1 protects the LM137HV in case the input supply is shorted  
 \*\*When  $C_2$  is larger than 10 μF and  $-V_{OUT}$  is larger than -25V, D2 protects the LM137HV in case the output is shorted

**High Stability -40V Regulator**

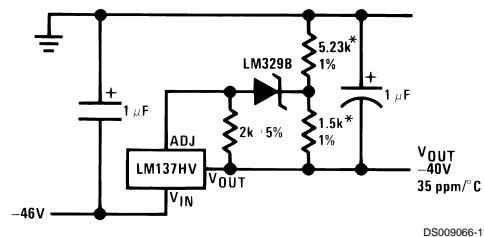

\*Use resistors with good tracking TC < 25 ppm/°C

## Typical Performance Characteristics (H and K-STEEL Package)

### Load Regulation

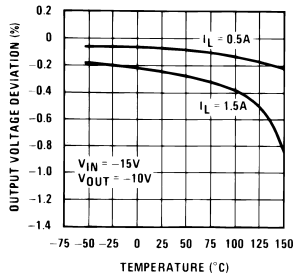

DS009066-13

### Current Limit

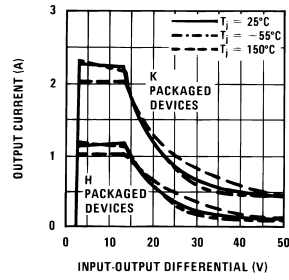

DS009066-14

### Adjustment Current

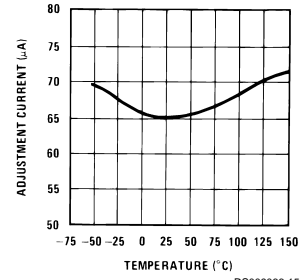

DS009066-15

### Dropout Voltage

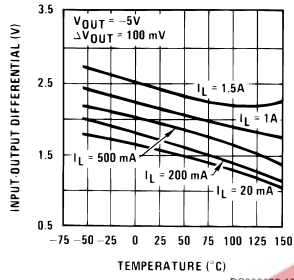

DS009066-16

### Temperature Stability

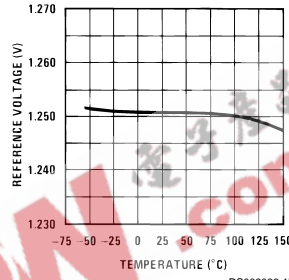

DS009066-17

### Minimum Operating Current

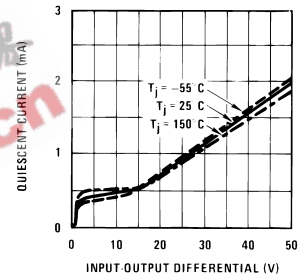

DS009066-18

### Ripple Rejection

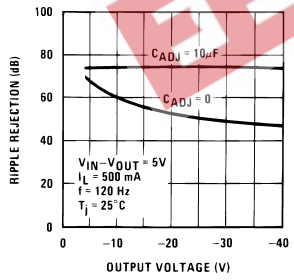

DS009066-19

### Ripple Rejection

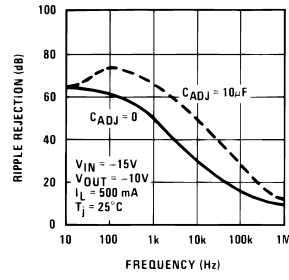

DS009066-20

### Ripple Rejection

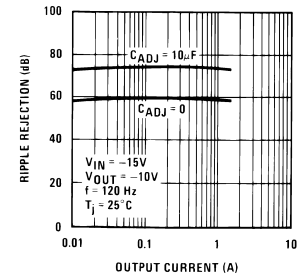

DS009066-21

## Typical Performance Characteristics (H and K-STEEL Package) (Continued)

### Output Impedance

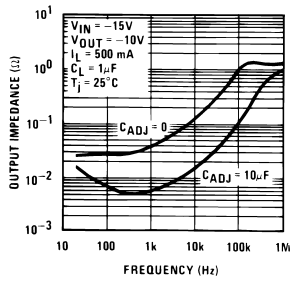

### Line Transient Response

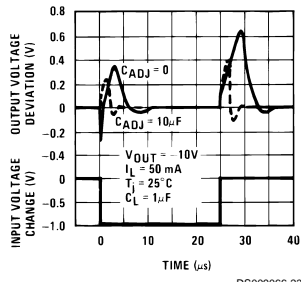

### Load Transient Response

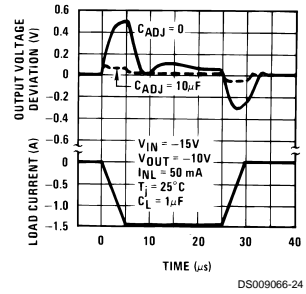

EEPW 电子产品世界  
 .com.cn

**Physical Dimensions** inches (millimeters) unless otherwise noted

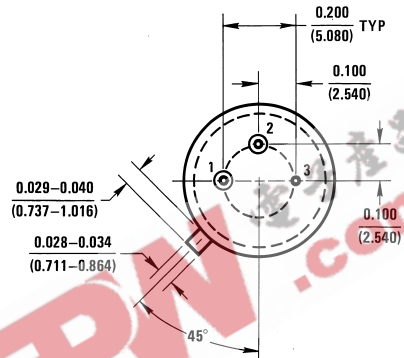
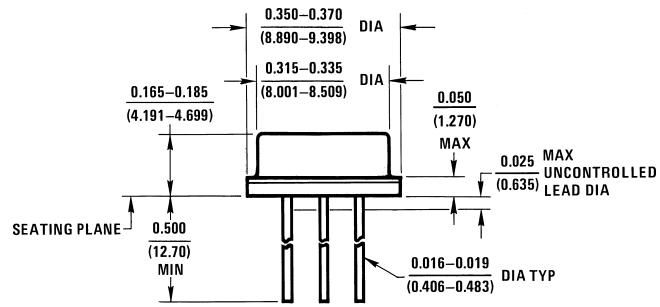

H03A (REV B)

**Metal Can Package (H)**  
**Order Number** LM137HVH/883, LM137HVH-QMLV, or LM337HVH  
**NS Package Number** H03A



**Physical Dimensions** inches (millimeters) unless otherwise noted (Continued)

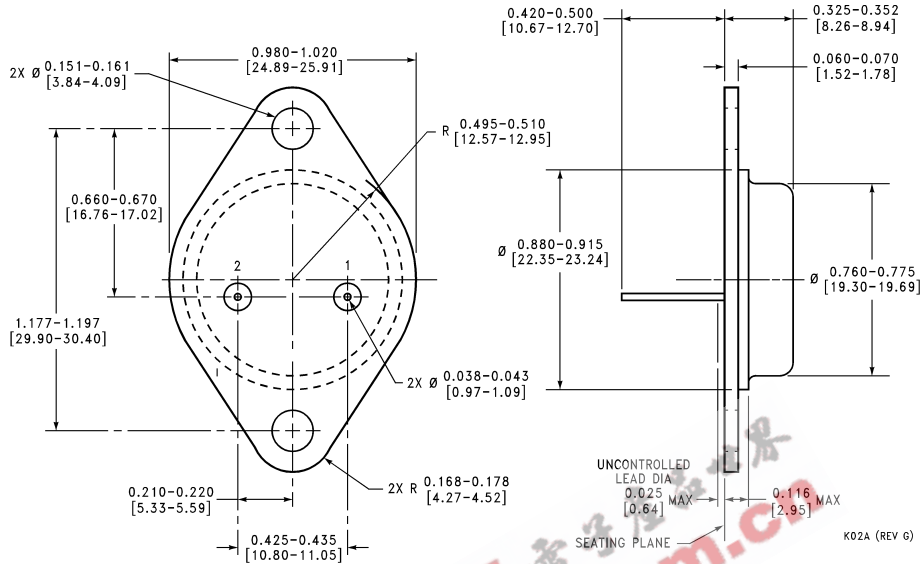

**Metal Can Package (K)**  
**Order Number LM337HVK STEEL**  
**NS Package Number K02A**

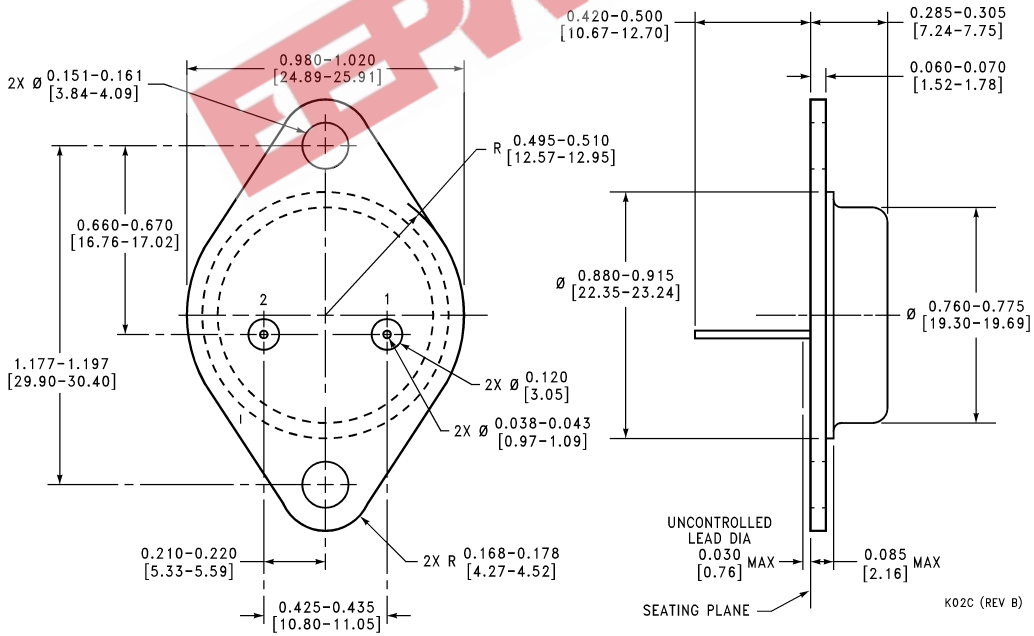

**Metal Can Package (K)**  
**Mil-Aero Products**  
**Order Number LM137HVK/883, LM137HVK-QMLV, or SMD #7703404**  
**NS Package Number K02C**

## Notes



### LIFE SUPPORT POLICY

NATIONAL'S PRODUCTS ARE NOT AUTHORIZED FOR USE AS CRITICAL COMPONENTS IN LIFE SUPPORT DEVICES OR SYSTEMS WITHOUT THE EXPRESS WRITTEN APPROVAL OF THE PRESIDENT AND GENERAL COUNSEL OF NATIONAL SEMICONDUCTOR CORPORATION. As used herein:

1. Life support devices or systems are devices or systems which, (a) are intended for surgical implant into the body, or (b) support or sustain life, and whose failure to perform when properly used in accordance with instructions for use provided in the labeling, can be reasonably expected to result in a significant injury to the user.
2. A critical component is any component of a life support device or system whose failure to perform can be reasonably expected to cause the failure of the life support device or system, or to affect its safety or effectiveness.



**National Semiconductor Corporation**  
Americas  
Tel: 1-800-272-9959  
Fax: 1-800-737-7018  
Email: support@nsc.com

www.national.com

**National Semiconductor Europe**

Fax: +49 (0) 1 80-530 85 86  
Email: europe.support@nsc.com  
Deutsch Tel: +49 (0) 1 80-530 85 85  
English Tel: +49 (0) 1 80-532 78 32  
Français Tel: +49 (0) 1 80-532 93 58  
Italiano Tel: +49 (0) 1 80-534 16 80

**National Semiconductor Asia Pacific Customer Response Group**

Tel: 65-2544466  
Fax: 65-2504466  
Email: sea.support@nsc.com

**National Semiconductor Japan Ltd.**

Tel: 81-3-5639-7560  
Fax: 81-3-5639-7507