



DUAL 4-INPUT MULTIPLEXER WITH 3-STATE OUTPUTS

The MC54/74F353 is a dual 4-input multiplexer with 3-state outputs. It can select two bits of data from four sources using common Select inputs. The outputs may be individually switched to a high impedance state with a HIGH on the respective Output Enable (\overline{OE}) inputs, allowing the outputs to interface directly with bus-oriented systems.

- Inverted Version of F253
- Multifunction Capability
- Separate Enables for Each Multiplexer

FUNCTIONAL DESCRIPTION

The MC54/74F353 contains two identical 4-input multiplexers with 3-state outputs. They select two bits from four sources selected by common Select inputs (S_0, S_1). The 4-input multiplexers have individual Output enable ($\overline{OE}_a, \overline{OE}_b$) inputs which, when HIGH, force the outputs to a high impedance (high Z) state. The logic equations for the outputs are shown below:

$$\overline{Z}_a = \overline{OE}_a \cdot (I_{0a} \cdot \overline{S}_1 \cdot \overline{S}_0 + I_{1a} \cdot \overline{S}_1 \cdot S_0 + I_{2a} \cdot S_1 \cdot \overline{S}_0 + I_{3a} \cdot S_1 \cdot S_0)$$

$$\overline{Z}_b = \overline{OE}_b \cdot (I_{0b} \cdot \overline{S}_1 \cdot \overline{S}_0 + I_{1b} \cdot \overline{S}_1 \cdot S_0 + I_{2b} \cdot S_1 \cdot \overline{S}_0 + I_{3b} \cdot S_1 \cdot S_0)$$

If the outputs of 3-state devices are tied together, all but one device must be in the high impedance state to avoid high currents that would exceed the maximum ratings. Designers should ensure that Output Enable signals to 3-state devices whose outputs are tied together are designed so that there is no overlap.

CONNECTION DIAGRAM (TOP VIEW)

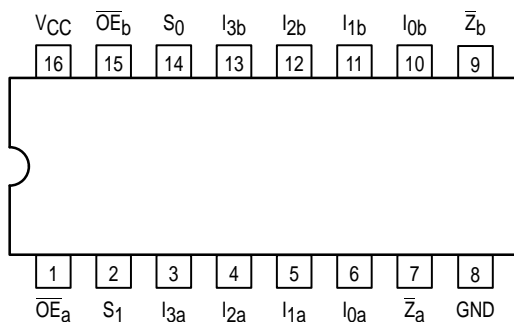

MC54/74F353

DUAL 4-INPUT MULTIPLEXER WITH 3-STATE OUTPUTS

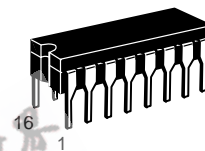

J SUFFIX
CERAMIC
CASE 620-09

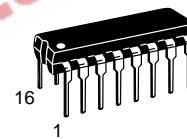

N SUFFIX
PLASTIC
CASE 648-08

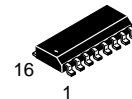

D SUFFIX
SOIC
CASE 751B-03

ORDERING INFORMATION

MC54FXXXJ	Ceramic
MC74FXXXN	Plastic
MC74FXXXD	SOIC

LOGIC SYMBOL

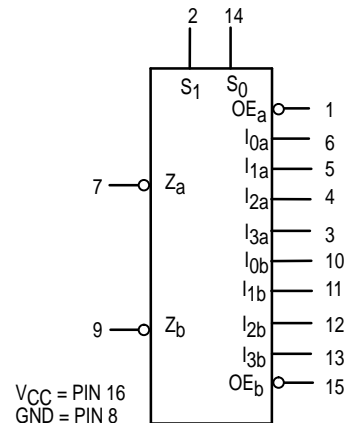

MC54/74F353

FUNCTION TABLE

Select Inputs		Data Inputs				Output Enable	Output
S ₀	S ₁	I ₀	I ₁	I ₂	I ₃	\overline{OE}	\overline{Z}
X	X	X	X	X	X	H	(Z)
L	L	L	X	X	X	L	H
L	L	H	X	X	X	L	L
H	L	X	L	X	X	L	H
H	L	X	H	X	X	L	L
L	H	X	X	L	X	L	H
L	H	X	X	H	X	L	L
H	H	X	X	X	L	L	H
H	H	X	X	X	H	L	L

Address inputs S₀ and S₁ are common to both sections.
 H = HIGH Voltage Level
 L = LOW Voltage Level
 X = Don't Care
 (Z) = High Impedance

LOGIC DIAGRAM

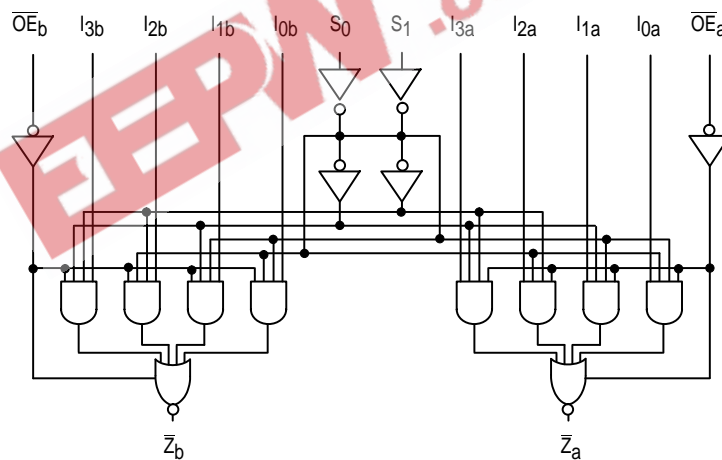

GUARANTEED OPERATING RANGES

Symbol	Parameter		Min	Typ	Max	Unit
V _{CC}	Supply Voltage	54, 74	4.5	5.0	5.5	V
T _A	Operating Ambient Temperature Range	54	-55	25	125	°C
		74	0	25	70	
I _{OH}	Output Current — High	54, 74			-3.0	mA
I _{OL}	Output Current — Low	54, 74			24	mA

MC54/74F353

DC CHARACTERISTICS OVER OPERATING TEMPERATURE RANGE (unless otherwise specified)

Symbol	Parameter	Limits			Unit	Test Conditions	
		Min	Typ	Max			
V _{IH}	Input HIGH Voltage	2.0			V	Guaranteed Input HIGH Voltage	
V _{IL}	Input LOW Voltage			0.8	V	Guaranteed Input LOW Voltage	
V _{IK}	Input Clamp Diode Voltage			-1.2	V	I _{IN} = -18 mA	V _{CC} = MIN
V _{OH}	Output HIGH Voltage	54, 74	2.4	3.3	V	I _{OH} = -3.0 mA	V _{CC} = 4.5 V
		74	2.7	3.3	V	I _{OH} = -3.0 mA	V _{CC} = 4.75 V
V _{OL}	Output LOW Voltage		0.35	0.5	V	I _{OL} = 24 mA	V _{CC} = MIN
I _{OZH}	Output OFF Current — HIGH			50	μA	V _{OUT} = 2.7 V	V _{CC} = MAX
I _{OZL}	Output OFF Current — LOW			-50	μA	V _{OUT} = 0.5 V	V _{CC} = MAX
I _{IH}	Input HIGH Current			20	μA	V _{IN} = 2.7 V	V _{CC} = MAX
				100		V _{IN} = 7.0 V	
I _{IL}	Input LOW Current			-0.6	mA	V _{IN} = 0.5 V	V _{CC} = MAX
I _{OS}	Output Short Circuit Current (Note 2)	-60		-150	mA	V _{OUT} = 0 V	V _{CC} = MAX
I _{CCH}	Power Supply Current		9.3	14	mA	I _n , S _n , \overline{OE}_n = GND	V _{CC} = MAX
I _{CCL}			13.3	20		I _n , S _n = GND	
I _{CCZ}			15	23		\overline{OE}_n = 4.5 V	

NOTES:

- For conditions shown as MIN or MAX, use the appropriate value specified under recommended operating conditions for the applicable device type.
- Not more than one output should be shorted at a time, nor for more than 1 second.

AC CHARACTERISTICS

Symbol	Parameter	54/74F		54F		74F		Unit
		T _A = +25°C		T _A = -55°C to +125°C		T _A = 0°C to +70°C		
		V _{CC} = +5.0 V C _L = 50 pF		V _{CC} = 5.0 V ± 10% C _L = 50 pF		V _{CC} = 5.0 V ± 10% C _L = 50 pF		
		Min	Max	Min	Max	Min	Max	
t _{PLH}	Propagation Delay	3.5	11	3.0	14	3.0	12.5	ns
t _{PHL}	S _n to \overline{Z}_n	3.0	8.5	2.5	11	2.5	9.5	
t _{PLH}	Propagation Delay	2.5	7.0	2.0	9.0	2.0	8.0	ns
t _{PHL}	I _n to \overline{Z}_n	1.0	3.5	1.0	5.0	1.0	4.0	
t _{PZH}	Output Enable Time	3.0	8.0	3.0	10.5	3.0	9.0	ns
t _{PZL}		3.5	8.0	3.0	10.5	3.0	9.0	
t _{PHZ}	Output Disable Time	2.0	5.0	2.0	7.0	1.5	6.0	
t _{PLZ}		2.0	6.0	1.5	8.0	1.5	7.0	