

8 BIT BINARY COUNTER WITH INPUT REGISTER (3-STATE)

- HIGH SPEED
 $f_{MAX} = 80 \text{ MHz (TYP.) AT } V_{CC} = 5 \text{ V}$
- LOW POWER DISSIPATION
 $I_{CC} = 4 \mu\text{A (MAX.) AT } T_A = 25 \text{ }^\circ\text{C}$
- OUTPUT DRIVE CAPABILITY
 10 LSTTL LOADS FOR \overline{RCO}
 15 LSTTL LOADS FOR Q_n
- BALANCED PROPAGATION DELAYS
 $t_{PLH} = t_{PHL}$
- SYMMETRICAL OUTPUT IMPEDANCE
 $I_{OL} = |I_{OH}| = 6 \text{ mA (MIN.) for } Q_n$
 $I_{OL} = |I_{OH}| = 4 \text{ mA (MIN.) for } \overline{RCO}$
- HIGH NOISE IMMUNITY
 $V_{NIH} = V_{NIL} = 28 \% V_{CC} \text{ (MIN.)}$
- WIDE OPERATING VOLTAGE RANGE
 $V_{CC} \text{ (OPR)} = 2 \text{ V TO } 6 \text{ V}$
- PIN AND FUNCTION COMPATIBLE WITH 54/74LS593

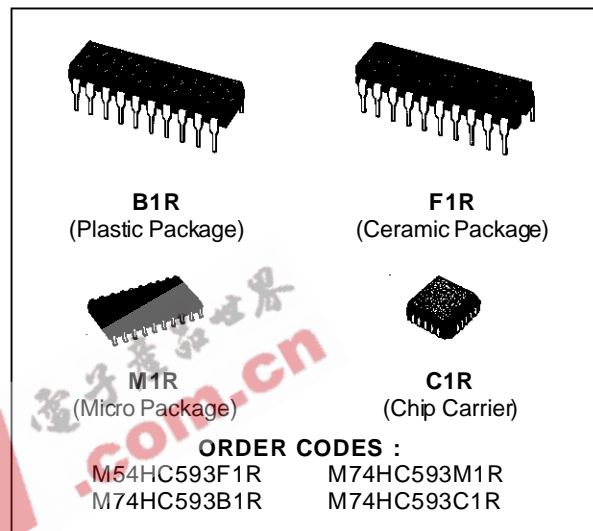

DESCRIPTION

The M54/74HC593 is a high speed CMOS 8 BIT REGISTER COUNTER (3 STATE) fabricated with silicon gate C²MOS technology. It has the same high speed performance of LSTTL combined with true CMOS low power consumption.

The M54/74HC593 consists of a parallel input, 8 bit storage register feeding an 8 bit binary counter. Both the register and the counter have individual positive edge-triggered clock. In addition, the counter has direct load and clear functions. Expansion is easily accomplished by connecting \overline{RCO} of first stage to the count enable \overline{CCKEN} , of the second stage etc.

The M54/74HC593 comes in a 20 pin package and has 3 state I/O, which provides parallel counter outputs.

All inputs are equipped with protection circuits against static discharge and transient excess voltage.

PIN CONNECTIONS (top view)

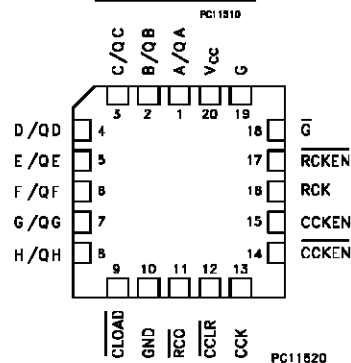
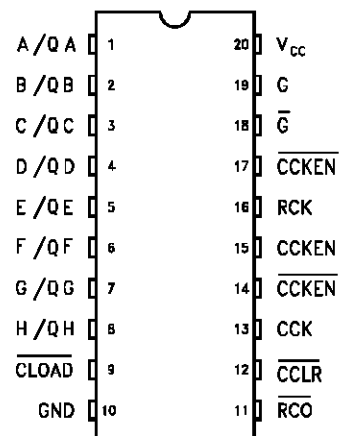

M54/M74HC593

INPUT AND OUTPUT EQUIVALENT CIRCUIT

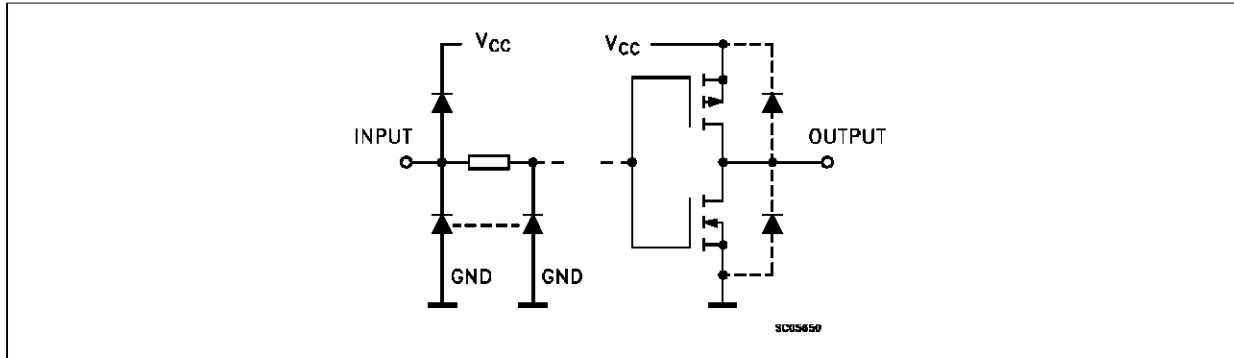

TRUTH TABLE

INPUTS									FUNCTION
G	\overline{G}	\overline{CCLR}	CCKEN	\overline{CCKEN}	CCK	\overline{CLOAD}	\overline{RCKEN}	RCK	
L	H	X	X	X	X	X	X	X	ALL Q BUS BECOME HIGH Z AND CAN BE APPLIED ANY DATA
H	X	X	X	X	X	X	X	X	THE OUTPUT DATA OF THE COUNTER IS ENABLE ON QA THRU QH
X	L	X	X	X	X	X	X	X	THE OUTPUT DATA OF THE COUNTER IS ENABLE ON QA THRU QH
X	X	L	X	X	X	H	X	X	COUNTER IS CLEARED TO ZERO
X	X	H	X	X	X	L	X	X	THE DATA OF Q BUS IS LOADED INTO COUNTER
X	X	H	H	X	\square	H	X	X	COUNTER ADVANCES THE COUNT
X	X	H	X	L	\square	H	X	X	COUNTER ADVANCES THE COUNT
X	X	H	H	X	\square	H	X	X	NO COUNT
X	X	H	X	L	\square	H	X	X	NO COUNT
X	X	H	L	H	X	H	X	X	NO COUNT
X	X	X	X	X	X	X	H	X	REGISTER DATA IS NOT CHANGED
X	X	X	X	X	X	X	L	\square	REGISTER DATA IS NOT CHANGED
X	X	X	X	X	X	X	L	\square	THE DATA OF Q BUS IS STORED INTO REGISTER

X: Don't Care

$$\overline{RCO} = \overline{QA'} \cdot \overline{QB'} \cdot \overline{QC'} \cdot \overline{QD'} \cdot \overline{QE'} \cdot \overline{QF'} \cdot \overline{QG'} \cdot \overline{QH'}$$

(QA' to QH': Internal outputs of the counter)

LOGIC DIAGRAM

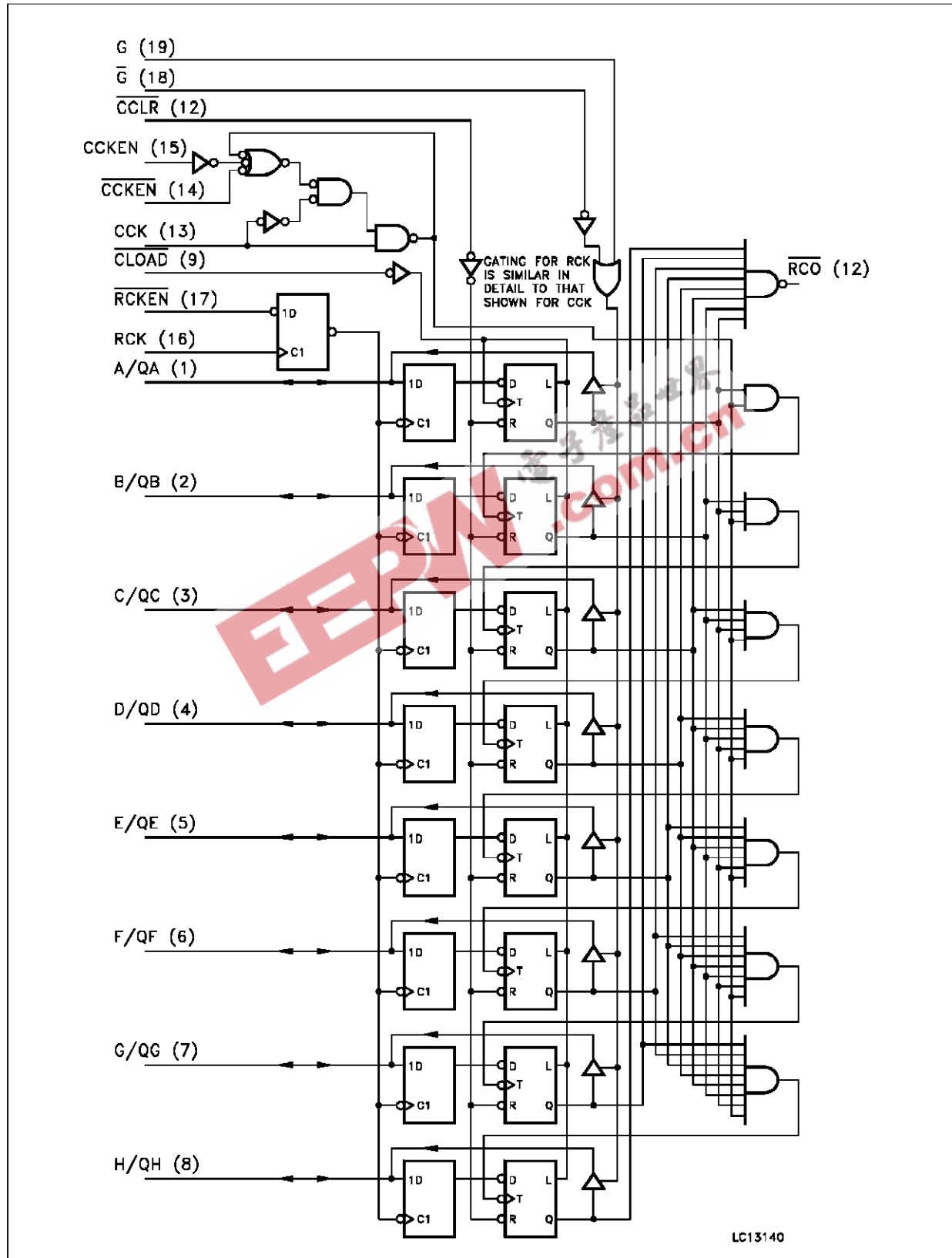

M54/M74HC593

PIN DESCRIPTION

PIN No	SYMBOL	NAME AND FUNCTION
1, 2, 3, 4, 5, 6, 7, 8	A/QA to H/QH	Binary Outputs
9	$\overline{\text{CLOAD}}$	Counter Clock Load Input
11	$\overline{\text{RCO}}$	Ripple Carry Output
12	$\overline{\text{CCLR}}$	Counter Clear Input
13	CCK	Counter Clock Input
14, 15	$\overline{\text{CCKEN}}$, $\overline{\text{CCKEN}}$	Counter Clock Enable Inputs
16	RCK	Register Clock Input
17	$\overline{\text{RCKEN}}$	Register Clock Enable Input
18, 19	$\overline{\text{G}}$, G	Output Enable
10	GND	Ground (0V)
20	V _{CC}	Positive Supply Voltage

IEC LOGIC SYMBOL

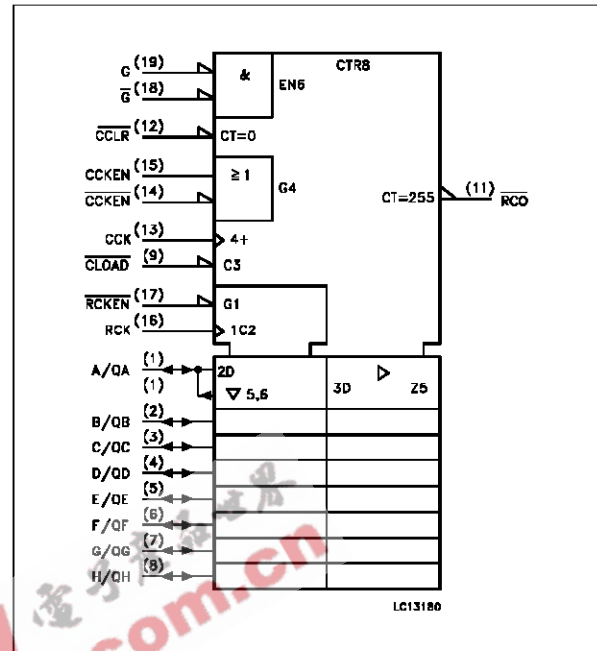

ABSOLUTE MAXIMUM RATINGS

Symbol	Parameter	Value	Unit
V _{CC}	Supply Voltage	-0.5 to +7	V
V _I	DC Input Voltage	-0.5 to V _{CC} + 0.5	V
V _O	DC Output Voltage	-0.5 to V _{CC} + 0.5	V
I _{IK}	DC Input Diode Current	± 20	mA
I _{OK}	DC Output Diode Current	± 20	mA
I _O	DC Output Source Sink Current Per Output Pin ($\overline{\text{RCO}}$) (QA - QH)	± 20 ± 35	mA
I _{CC} or I _{GND}	DC V _{CC} or Ground Current	± 70	mA
P _D	Power Dissipation	500 (*)	mW
T _{stg}	Storage Temperature	-65 to +150	°C
T _L	Lead Temperature (10 sec)	300	°C

Absolute Maximum Ratings are those values beyond which damage to the device may occur. Functional operation under these conditions is not implied.

(*) 500 mW: ≅ 65 °C derate to 300 mW by 10mW/°C: 65 °C to 85 °C

RECOMMENDED OPERATING CONDITIONS

Symbol	Parameter	Value	Unit	
V _{CC}	Supply Voltage	2 to 6	V	
V _I	Input Voltage	0 to V _{CC}	V	
V _O	Output Voltage	0 to V _{CC}	V	
T _{op}	Operating Temperature: M54HC Series M74HC Series	-55 to +125 -40 to +85	°C °C	
t _r , t _f	Input Rise and Fall Time	V _{CC} = 2 V V _{CC} = 4.5 V V _{CC} = 6 V	0 to 1000 0 to 500 0 to 400	ns

DC SPECIFICATIONS

Symbol	Parameter	Test Conditions		Value						Unit		
		V _{CC} (V)		T _A = 25 °C 54HC and 74HC			-40 to 85 °C 74HC		-55 to 125 °C 54HC			
				Min.	Typ.	Max.	Min.	Max.	Min.		Max.	
V _{IH}	High Level Input Voltage	2.0		1.5			1.5		1.5		V	
		4.5		3.15			3.15		3.15			
		6.0		4.2			4.2		4.2			
V _{IL}	Low Level Input Voltage	2.0				0.5		0.5		0.5	V	
		4.5				1.35		1.35		1.35		
		6.0				1.8		1.8		1.8		
V _{OH}	High Level Output Voltage (RCO)	2.0	V _I = V _{IH} or V _{IL}	I _O = -20 μA	1.9	2.0		1.9		1.9	V	
		4.5			4.4	4.5		4.4		4.4		
		6.0			5.9	6.0		5.9		5.9		
		4.5		I _O = -4.0 mA	4.18	4.31		4.13		4.10		
		6.0		I _O = -5.2 mA	5.68	5.8		5.63		5.60		
V _{OH}	High Level Output Voltage (QA - QH)	2.0	V _I = V _{IH} or V _{IL}	I _O = -20 μA	1.9	2.0		1.9		1.9	V	
		4.5			4.4	4.5		4.4		4.4		
		6.0			5.9	6.0		5.9		5.9		
		4.5		I _O = -6.0 mA	4.18	4.31		4.13		4.10		
		6.0		I _O = -7.8 mA	5.68	5.8		5.63		5.60		
V _{OL}	Low Level Output Voltage (RCO)	2.0	V _I = V _{IH} or V _{IL}	I _O = 20 μA		0.0	0.1		0.1		0.1	V
		4.5				0.0	0.1		0.1		0.1	
		6.0				0.0	0.1		0.1		0.1	
		4.5		I _O = 4.0 mA		0.17	0.26		0.33		0.40	
		6.0		I _O = 5.2 mA		0.18	0.26		0.33		0.40	
V _{OL}	Low Level Output Voltage (QA - QH)	2.0	V _I = V _{IH} or V _{IL}	I _O = 20 μA		0.0	0.1		0.1		0.1	V
		4.5				0.0	0.1		0.1		0.1	
		6.0				0.0	0.1		0.1		0.1	
		4.5		I _O = 6.0 mA		0.17	0.26		0.33		0.40	
		6.0		I _O = 7.8 mA		0.18	0.26		0.33		0.40	
I _I	Input Leakage Current	6.0	V _I = V _{CC} or GND			±0.1		±1		±1	μA	
I _{OZ}	3 State Output Off State Current	6.0	V _I = V _{IH} or V _{IL} V _O = V _{CC} or GND			±0.5		±5.0		±10	μA	
I _{CC}	Quiescent Supply Current	6.0	V _I = V _{CC} or GND			4		40		80	μA	

M54/M74HC593

AC ELECTRICAL CHARACTERISTICS (Input $t_r = t_f = 6$ ns)

Symbol	Parameter	Test Conditions			Value						Unit	
		V _{CC} (V)	C _L (pF)		T _A = 25 °C 54HC and 74HC			-40 to 85 °C 74HC		-55 to 125 °C 54HC		
					Min.	Typ.	Max.	Min.	Max.	Min.		Max.
t _{TLH} t _{THL}	Output Transition Time (RCO)	2.0	50		30	75		95		110	ns	
		4.5		8	15		19		22			
		6.0		7	13		16		19			
t _{TLH} t _{THL}	Output Transition Time (Qn)	2.0	50		20	60		75		90	ns	
		4.5		7	12		15		18			
		6.0		6	10		13		15			
t _{PLH} t _{PHL}	Propagation Delay Time (CCK - Qn)	2.0	50		108	210		265		315	ns	
		4.5		27	42		53		63			
		6.0		23	36		45		54			
		2.0	150		124	240		300		360	ns	
		4.5		31	48		60		72			
		6.0		26	41		51		61			
t _{PLH} t _{PHL}	Propagation Delay Time (CLOAD - Qn)	2.0	50		108	210		265		315	ns	
		4.5		27	42		53		63			
		6.0		23	36		45		54			
		2.0	150		124	240		300		360	ns	
		4.5		31	48		60		72			
		6.0		26	41		51		61			
t _{PHL}	Propagation Delay Time (CCLR - Qn)	2.0	50		112	220		275		330	ns	
		4.5		28	44		55		66			
		6.0		24	37		47		56			
		2.0	150		128	250		315		375	ns	
		4.5		32	50		63		75			
		6.0		27	43		54		64			
t _{PLH} t _{PHL}	Propagation Delay Time (CCK - RCO)	2.0	50		144	250		315		375	ns	
		4.5		36	50		63		75			
		6.0		31	10		54		64			
t _{PLH} t _{PHL}	Propagation Delay Time (CLOAD - RCO)	2.0	50		152	295		370		445	ns	
		4.5		38	59		74		89			
		6.0		32	50		63		76			
t _{PLH} t _{PHL}	Propagation Delay Time (CCLR - RCO)	2.0	50		116	225		280		340	ns	
		4.5		29	45		56		68			
		6.0		25	38		48		58			
t _{PLH} t _{PHL}	Propagation Delay Time (RCK - RCO)	2.0	50		188	360		450		540	ns	
		4.5		47	72		90		108			
		6.0		40	61		77		93			
t _{PZL} t _{PZH}	3 State Output Enable Time	2.0	50	R _L = 1 KΩ		72	145		180		220	ns
		4.5			18	29		36		44		
		6.0			15	25		31		38		
		2.0	150	R _L = 1 KΩ		88	175		220		265	ns
		4.5			22	35		44		53		
		6.0			19	30		37		45		

AC ELECTRICAL CHARACTERISTICS (continued)

Symbol	Parameter	Test Conditions			Value						Unit	
		V _{CC} (V)	C _L (pF)	R _L = 1 KΩ	T _A = 25 °C 54HC and 74HC			-40 to 85 °C 74HC		-55 to 125 °C 54HC		
					Min.	Typ.	Max.	Min.	Max.	Min.		Max.
t _{PLZ} t _{PHZ}	3 State Output Disable Time	2.0	50	R _L = 1 KΩ		80	140		175		210	ns
		4.5				22	28		35		42	
		6.0				17	24		30		36	
f _{MAX}	Maximum Clock Frequency	2.0	50		5.4	4		4.4		3.6		MHz
		4.5			27	17		22		18		
		6.0			32	20		26		21		
t _{W(H)} t _{W(L)}	Minimum Pulse Width (CCK, RCK)	2.0	50			44	100		125		150	ns
		4.5				11	20		25		30	
		6.0				9	17		21		26	
t _{W(L)}	Minimum Pulse Width (CCLR, CLOAD)	2.0	50			40	100		125		150	ns
		4.5				10	20		25		30	
		6.0				9	17		21		26	
t _s	Minimum Set-up Time (CCKEN, CCKEN, CCK)	2.0	50			56	125		160		195	ns
		4.5				14	25		32		39	
		6.0				12	21		27		33	
t _s	Minimum Set-up Time (RCKEN - RCK)	2.0	50			32	75		95		110	ns
		4.5				8	15		19		22	
		6.0				7	13		16		19	
t _{s(H)}	Minimum Set-up Time (RCK - CLOAD)	2.0	50			56	125		160		195	ns
		4.5				14	25		32		39	
		6.0				12	21		27		33	
t _s	Minimum Set-up Time (A to H - RCK)	2.0	50			16	50		60		70	ns
		4.5				4	10		12		14	
		6.0				3	9		11		12	
t _h	Minimum Hold Time	2.0	50			0	0		0		0	ns
		4.5				0	0		0		0	
		6.0				0	0		0		0	
t _{REM}	Minimum Clear Removal Time (CCLR, CLOAD)	2.0	50				5				5	ns
		4.5						5			5	
		6.0						5			5	
C _{IN}	Input Capacitance					5	10		10		10	pF
C _{PD} (*)	Power Dissipation Capacitance					19						pF

(*) C_{PD} is defined as the value of the IC's internal equivalent capacitance which is calculated from the operating current consumption without load. (Refer to Test Circuit). Average operating current can be obtained by the following equation. $I_{CC(opr)} = C_{PD} \cdot V_{CC} \cdot f_{IN} + I_{CC}$

Plastic DIP20 (0.25) MECHANICAL DATA

DIM.	mm			inch		
	MIN.	TYP.	MAX.	MIN.	TYP.	MAX.
a1	0.254			0.010		
B	1.39		1.65	0.055		0.065
b		0.45			0.018	
b1		0.25			0.010	
D			25.4			1.000
E		8.5			0.335	
e		2.54			0.100	
e3		22.86			0.900	
F			7.1			0.280
I			3.93			0.155
L		3.3			0.130	
Z			1.34			0.053

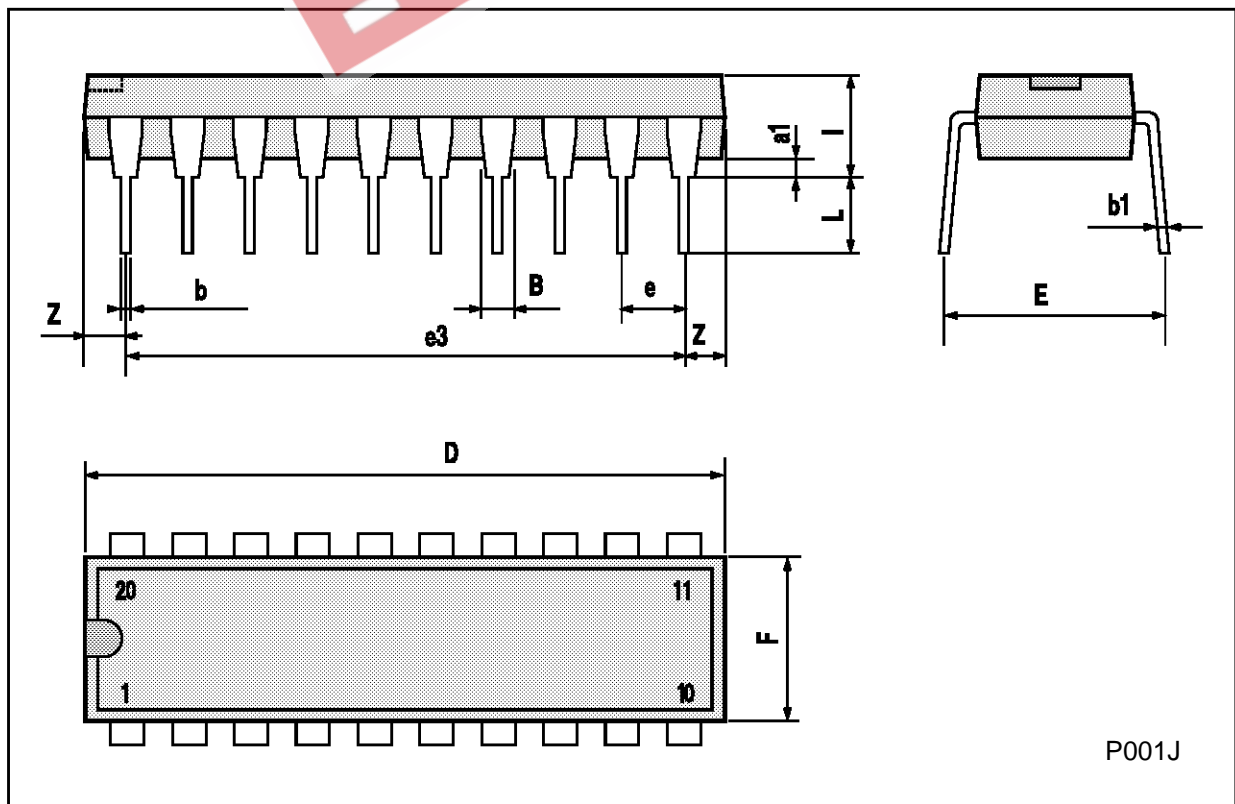

Ceramic DIP20 MECHANICAL DATA

DIM.	mm			inch		
	MIN.	TYP.	MAX.	MIN.	TYP.	MAX.
A			25			0.984
B			7.8			0.307
D		3.3			0.130	
E	0.5		1.78	0.020		0.070
e3		22.86			0.900	
F	2.29		2.79	0.090		0.110
G	0.4		0.55	0.016		0.022
I	1.27		1.52	0.050		0.060
L	0.22		0.31	0.009		0.012
M	0.51		1.27	0.020		0.050
N1	4° (min.), 15° (max.)					
P	7.9		8.13	0.311		0.320
Q			5.71			0.225

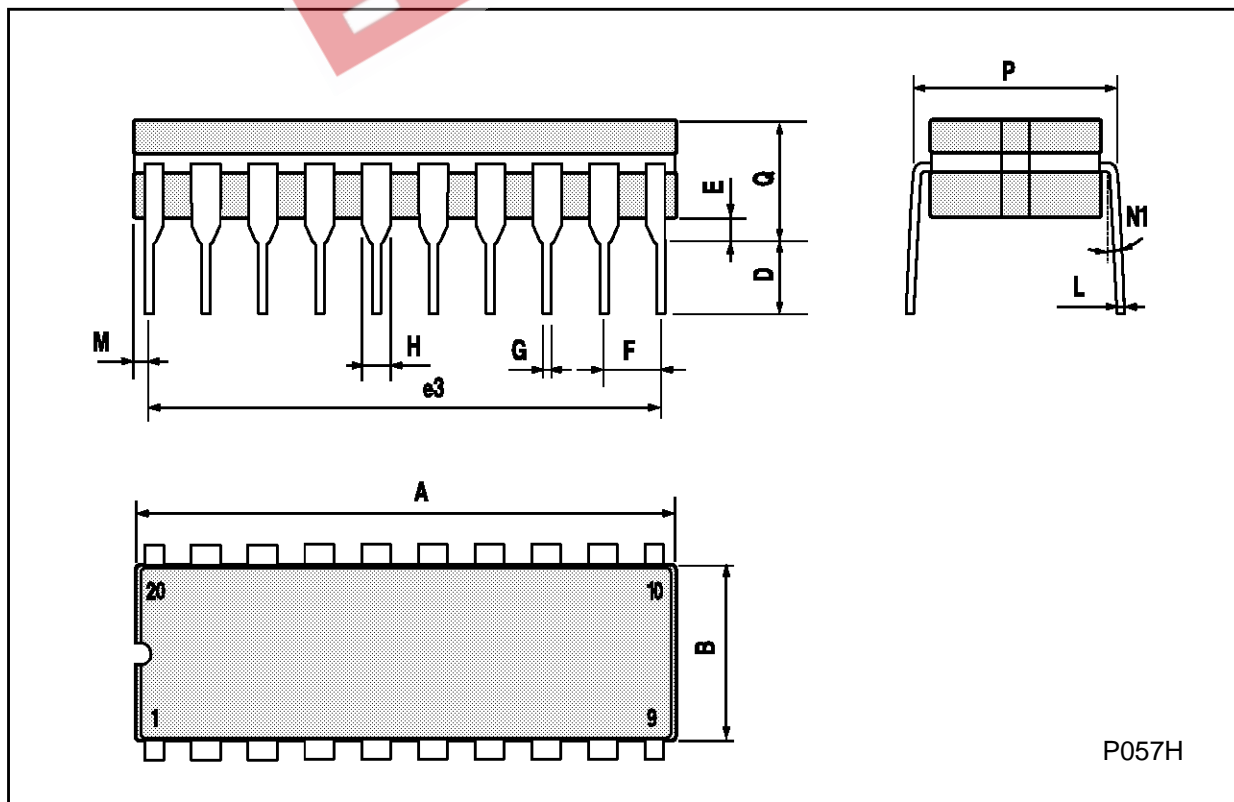

SO20 MECHANICAL DATA

DIM.	mm			inch		
	MIN.	TYP.	MAX.	MIN.	TYP.	MAX.
A			2.65			0.104
a1	0.10		0.20	0.004		0.007
a2			2.45			0.096
b	0.35		0.49	0.013		0.019
b1	0.23		0.32	0.009		0.012
C		0.50			0.020	
c1	45° (typ.)					
D	12.60		13.00	0.496		0.512
E	10.00		10.65	0.393		0.419
e		1.27			0.050	
e3		11.43			0.450	
F	7.40		7.60	0.291		0.299
L	0.50		1.27	0.19		0.050
M			0.75			0.029
S	8° (max.)					

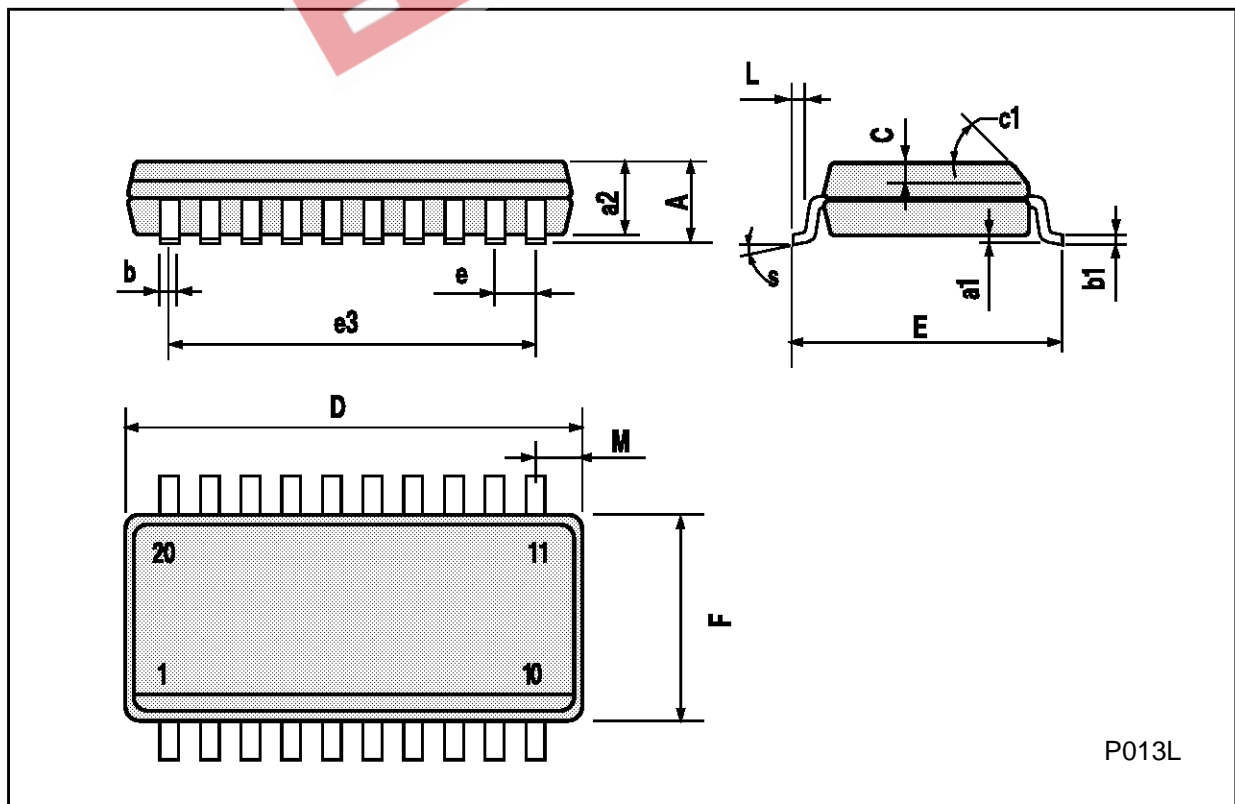

P013L

PLCC20 MECHANICAL DATA

DIM.	mm			inch		
	MIN.	TYP.	MAX.	MIN.	TYP.	MAX.
A	9.78		10.03	0.385		0.395
B	8.89		9.04	0.350		0.356
D	4.2		4.57	0.165		0.180
d1		2.54			0.100	
d2		0.56			0.022	
E	7.37		8.38	0.290		0.330
e		1.27			0.050	
e3		5.08			0.200	
F		0.38			0.015	
G			0.101			0.004
M		1.27			0.050	
M1		1.14			0.045	

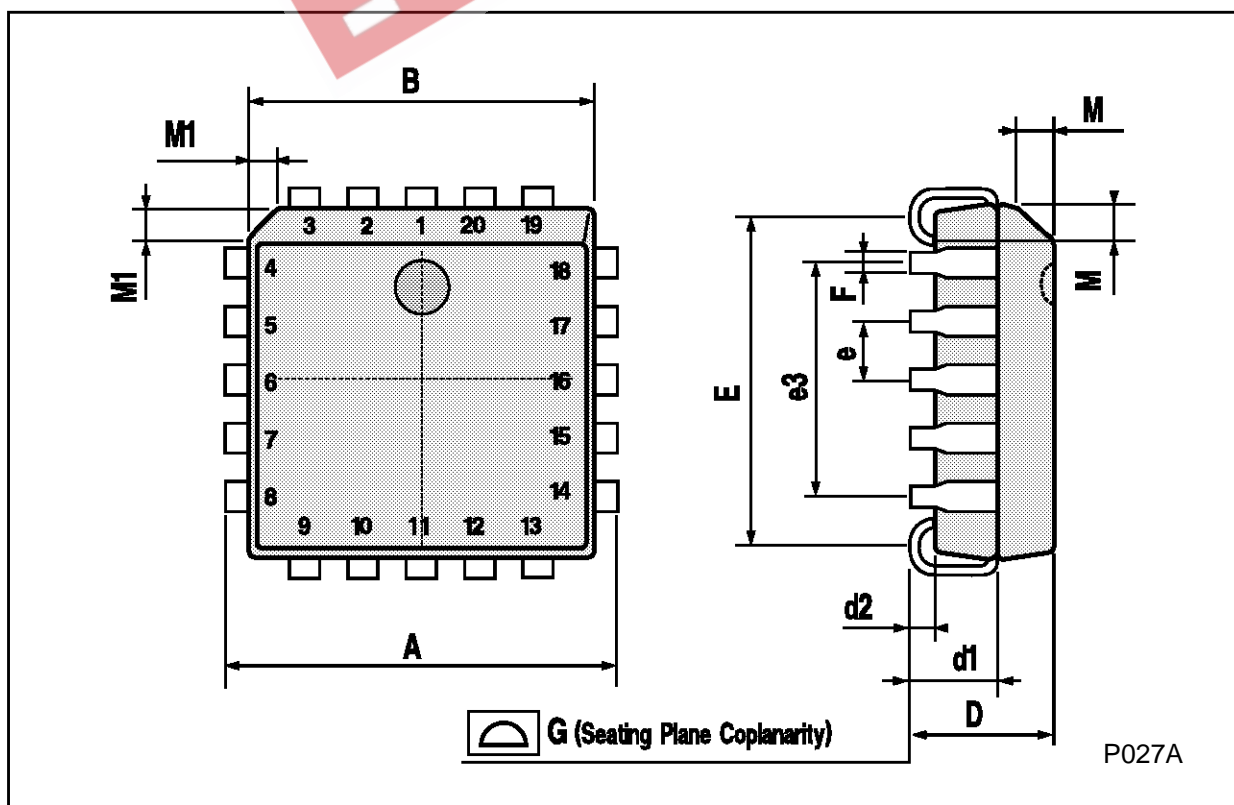

EEPW 电子產品世界
.com.cn

Information furnished is believed to be accurate and reliable. However, SGS-THOMSON Microelectronics assumes no responsibility for the consequences of use of such information nor for any infringement of patents or other rights of third parties which may result from its use. No license is granted by implication or otherwise under any patent or patent rights of SGS-THOMSON Microelectronics. Specifications mentioned in this publication are subject to change without notice. This publication supersedes and replaces all information previously supplied. SGS-THOMSON Microelectronics products are not authorized for use as critical components in life support devices or systems without express written approval of SGS-THOMSON Microelectronics.

© 1994 SGS-THOMSON Microelectronics - All Rights Reserved

SGS-THOMSON Microelectronics GROUP OF COMPANIES
Australia - Brazil - France - Germany - Hong Kong - Italy - Japan - Korea - Malaysia - Malta - Morocco - The Netherlands -
Singapore - Spain - Sweden - Switzerland - Taiwan - Thailand - United Kingdom - U.S.A