



MC74AC350 MC74ACT350

4-BIT SHIFTER WITH 3-STATE OUTPUTS

4-Bit Shifter With 3-State Outputs

The MC74AC350/74ACT350 is a specialized multiplexer that accepts a 4-bit word and shifts it 0, 1, 2 or 3 places, as determined by two Select (S_0 , S_1) inputs. For expansion to longer words, three linking inputs are provided for lower-order bits; thus two packages can shift an 8-bit word, four packages a 16-bit word, etc. Shifting by more than three places is accomplished by paralleling the 3-state outputs of different packages and using the Output Enable (OE) inputs as a third Select level. With appropriate interconnections, the 'AC/ACT350 can perform zero-backfill, sign-extend or end-around (barrel) shift functions.

- Linking Inputs for Word Expansion
- 3-State Outputs for Extending Shift Range

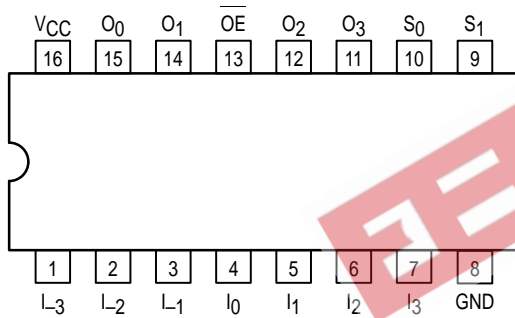

N SUFFIX
CASE 648-08
PLASTIC

D SUFFIX
CASE 751B-05
PLASTIC

TRUTH TABLE

Inputs			Outputs			
OE	S_1	S_0	O_0	O_1	O_2	O_3
H	X	X	Z	Z	Z	Z
L	L	L	I_0	I_1	I_2	I_3
L	L	H	L_{-1}	I_0	I_1	I_2
L	H	L	L_{-2}	L_{-1}	I_0	I_1
L	H	H	L_{-3}	L_{-2}	L_{-1}	I_0

H = HIGH Voltage Level
L = LOW Voltage Level
X = Immaterial

LOGIC SYMBOL

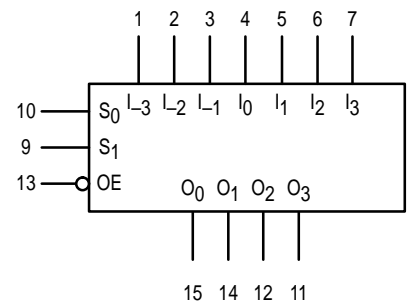

MC74AC350 MC74ACT350

FUNCTIONAL DESCRIPTION

The MC74AC350/74ACT350 is operationally equivalent to a 4-input multiplexer with the inputs connected so that the select code causes successive one-bit shifts of the data word. This internal connection makes it possible to perform shifts of 0, 1, 2 or 3 places on words of any length.

A 7-bit data word is introduced at the I_n inputs and is shifted according to the code applied to the select inputs S_0, S_1 . Outputs O_0-O_3 are 3-state, controlled by an active-LOW output enable (\overline{OE}). When \overline{OE} is LOW, data outputs will follow selected data inputs; when HIGH, the data outputs will be forced to the high-impedance state. This feature allows

shifters to be cascaded on the same output lines or to a common bus. The shift function can be logical, with zeros pulled in at either or both ends of the shifting field; arithmetic, where the sign bit is repeated during a shift down; or end around, where the data word forms a continuous loop.

LOGIC EQUATIONS

$$O_0 = \overline{S_0} \overline{S_1} I_0 + S_0 \overline{S_1} I_{-1} + \overline{S_0} S_1 I_{-2} + S_0 S_1 I_{-3}$$

$$O_1 = \overline{S_0} \overline{S_1} I_1 + S_0 \overline{S_1} I_0 + \overline{S_0} S_1 I_{-1} + S_0 S_1 I_{-2}$$

$$O_2 = \overline{S_0} \overline{S_1} I_2 + S_0 \overline{S_1} I_1 + \overline{S_0} S_1 I_0 + S_0 S_1 I_{-1}$$

$$O_3 = S_0 S_1 I_3 + S_0 S_1 I_2 + S_0 S_1 I_1 + S_0 S_1 I_0$$

LOGIC DIAGRAM

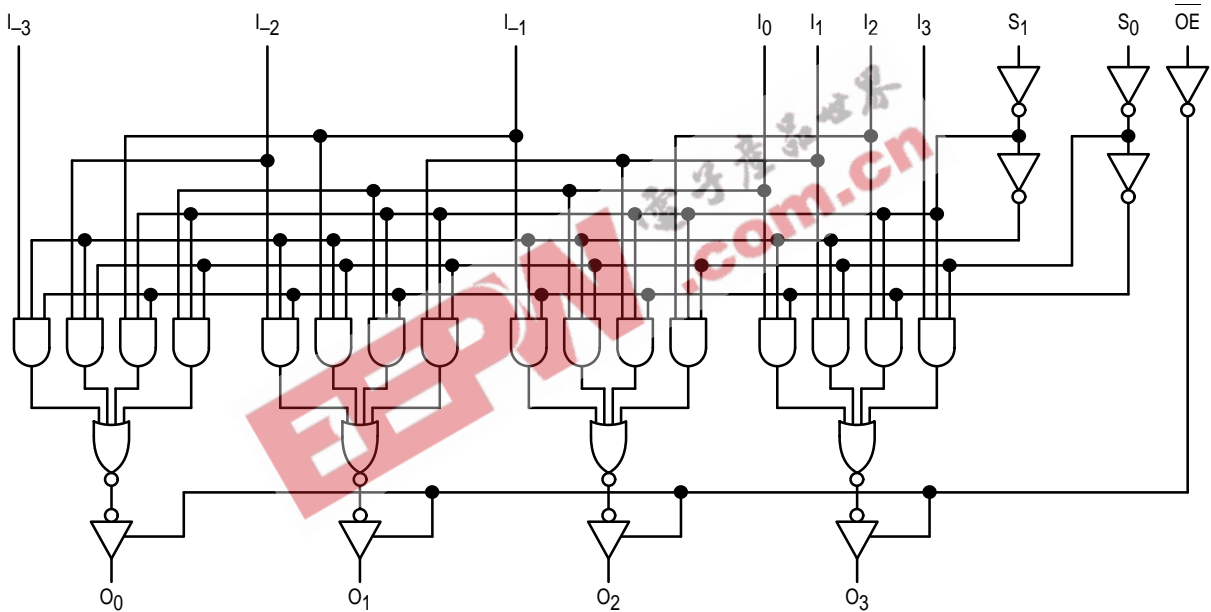

MC74AC350 MC74ACT350

APPLICATIONS

16-Bit Shift-Up 0 to 3 Places, Zero Backfill

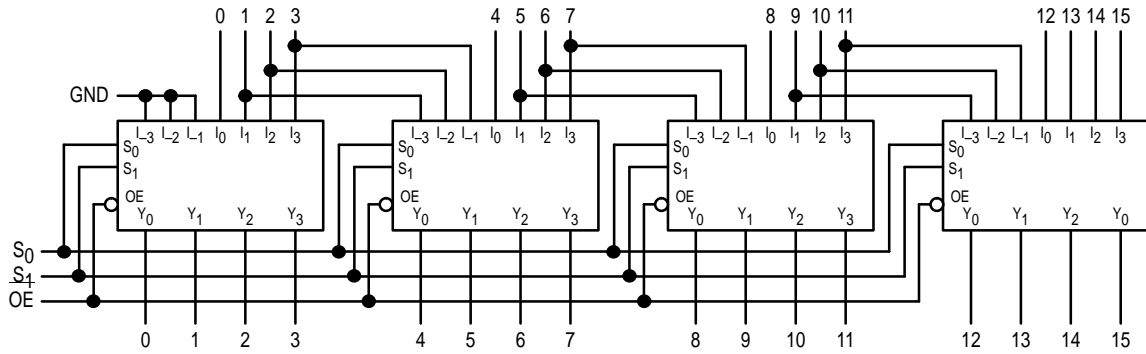

S ₁	S ₀	
L	L	NO SHIFT
L	H	SHIFT 1 PLACE
H	L	SHIFT 2 PLACES
H	H	SHIFT 3 PLACES

8-Bit End Around Shift 0 to 7 Places

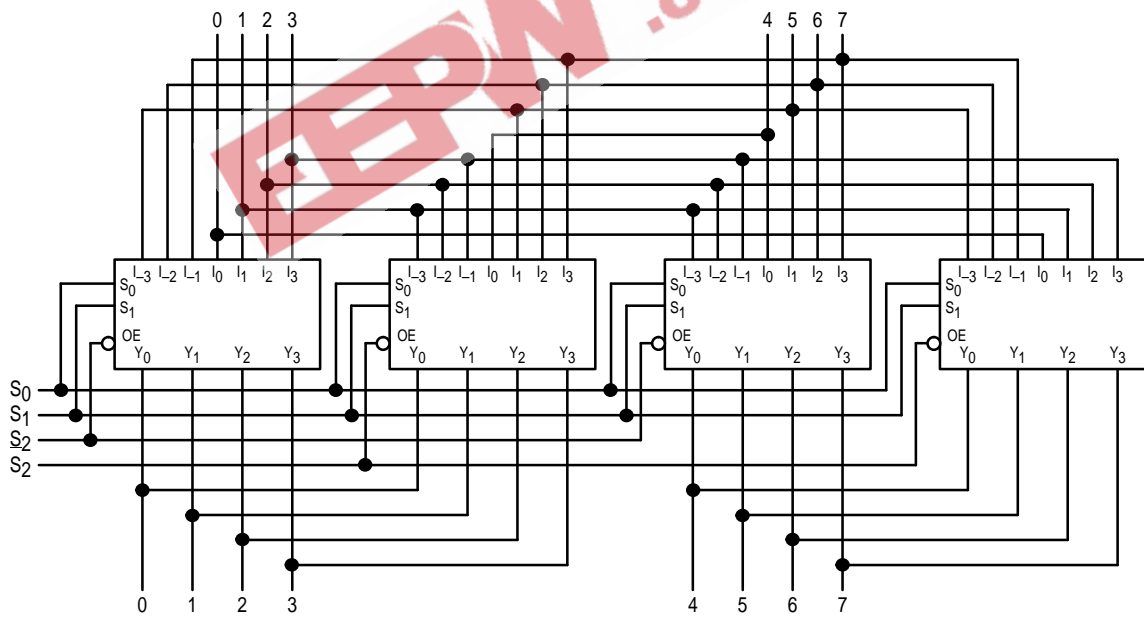

S ₂	S ₁	S ₀	
L	L	L	NO SHIFT
L	L	H	SHIFT END AROUND 1
L	H	L	SHIFT END AROUND 2
L	H	H	SHIFT END AROUND 3
H	L	L	SHIFT END AROUND 4

S ₂	S ₁	S ₀	
H	L	H	SHIFT END AROUND 5
H	H	L	SHIFT END AROUND 6
H	H	H	SHIFT END AROUND 7

MC74AC350 MC74ACT350

13-Bit Twos Complement Scaler

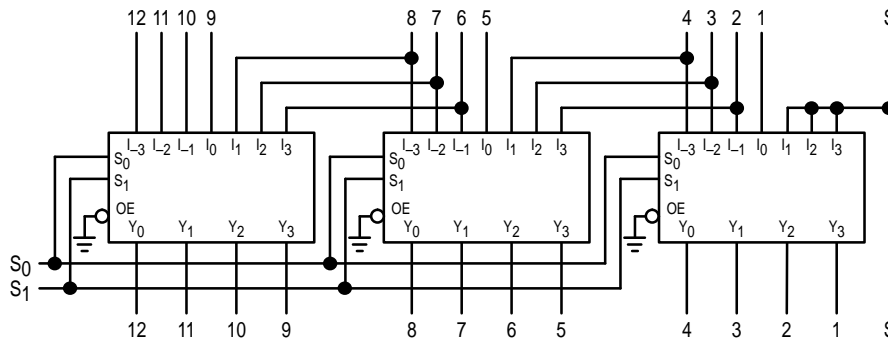

S ₁	S ₀	SCALE
L	L ÷ 8	1/8
L	H ÷ 4	1/4
H	L ÷ 2	1/2
H	H NO CHANGE	1

MAXIMUM RATINGS*

Symbol	Parameter	Value	Unit
V _{CC}	DC Supply Voltage (Referenced to GND)	-0.5 to +7.0	V
V _{in}	DC Input Voltage (Referenced to GND)	-0.5 to V _{CC} + 0.5	V
V _{out}	DC Output Voltage (Referenced to GND)	-0.5 to V _{CC} + 0.5	V
I _{in}	DC Input Current, per Pin	±20	mA
I _{out}	DC Output Sink/Source Current, per Pin	±50	mA
I _{CC}	DC V _{CC} or GND Current per Output Pin	±50	mA
T _{stg}	Storage Temperature	-65 to +150	°C

* Maximum Ratings are those values beyond which damage to the device may occur. Functional operation should be restricted to the Recommended Operating Conditions.

RECOMMENDED OPERATING CONDITIONS

Symbol	Parameter	Min	Typ	Max	Unit	
V _{CC}	Supply Voltage	'AC	2.0	5.0	6.0	V
		'ACT	4.5	5.0	5.5	
V _{in} , V _{out}	DC Input Voltage, Output Voltage (Ref. to GND)	0		V _{CC}	V	
t _r , t _f	Input Rise and Fall Time (Note 1) 'AC Devices except Schmitt Inputs	V _{CC} @ 3.0 V		150	ns/V	
		V _{CC} @ 4.5 V		40		
		V _{CC} @ 5.5 V		25		
t _r , t _f	Input Rise and Fall Time (Note 2) 'ACT Devices except Schmitt Inputs	V _{CC} @ 4.5 V		10	ns/V	
		V _{CC} @ 5.5 V		8.0		
T _J	Junction Temperature (PDIP)			140	°C	
T _A	Operating Ambient Temperature Range	-40	25	85	°C	
I _{OH}	Output Current — High			-24	mA	
I _{OL}	Output Current — Low			24	mA	

1. V_{in} from 30% to 70% V_{CC}; see individual Data Sheets for devices that differ from the typical input rise and fall times.

2. V_{in} from 0.8 V to 2.0 V; see individual Data Sheets for devices that differ from the typical input rise and fall times.

MC74AC350 MC74ACT350

DC CHARACTERISTICS

Symbol	Parameter	V _{CC} (V)	74AC		74AC		Unit	Conditions
			T _A = +25°C		T _A = -40°C to +85°C			
			Typ	Guaranteed Limits				
V _{IH}	Minimum High Level Input Voltage	3.0	1.5	2.1	2.1		V	V _{OUT} = 0.1 V or V _{CC} - 0.1 V
		4.5	2.25	3.15	3.15			
		5.5	2.75	3.85	3.85			
V _{IL}	Maximum Low Level Input Voltage	3.0	1.5	0.9	0.9		V	V _{OUT} = 0.1 V or V _{CC} - 0.1 V
		4.5	2.25	1.35	1.35			
		5.5	2.75	1.65	1.65			
V _{OH}	Minimum High Level Output Voltage	3.0	2.99	2.9	2.9		V	I _{OUT} = -50 μA
		4.5	4.49	4.4	4.4			
		5.5	5.49	5.4	5.4			
		3.0		2.56	2.46		V	*V _{IN} = V _{IL} or V _{IH} -12 mA I _{OH} -24 mA -24 mA
		4.5		3.86	3.76			
		5.5		4.86	4.76			
V _{OL}	Maximum Low Level Output Voltage	3.0	0.002	0.1	0.1		V	I _{OUT} = 50 μA
		4.5	0.001	0.1	0.1			
		5.5	0.001	0.1	0.1			
		3.0		0.36	0.44		V	*V _{IN} = V _{IL} or V _{IH} 12 mA I _{OL} 24 mA 24 mA
		4.5		0.36	0.44			
		5.5		0.36	0.44			
I _{IN}	Maximum Input Leakage Current	5.5		±0.1	±1.0		μA	V _I = V _{CC} , GND
I _{OZ}	Maximum 3-State Current	5.5		±0.5	±5.0		μA	V _I (OE) = V _{IL} , V _{IH} V _I = V _{CC} , GND V _O = V _{CC} , GND
I _{OLD}	†Minimum Dynamic Output Current	5.5			75		mA	V _{OLD} = 1.65 V Max
I _{OHD}		5.5			-75		mA	V _{OHD} = 3.85 V Min
I _{CC}	Maximum Quiescent Supply Current	5.5		8.0	80		μA	V _{IN} = V _{CC} or GND

* All outputs loaded; thresholds on input associated with output under test.

† Maximum test duration 2.0 ms, one output loaded at a time.

Note: I_{IN} and I_{CC} @ 3.0 V are guaranteed to be less than or equal to the respective limit @ 5.5 V V_{CC}.

MC74AC350 MC74ACT350

AC CHARACTERISTICS (For Figures and Waveforms — See Section 3)

Symbol	Parameter	V _{CC} * (V)	74AC			74AC		Unit	Fig. No.
			T _A = +25°C C _L = 50 pF			T _A = -40°C to +85°C C _L = 50 pF			
			Min	Typ	Max	Min	Max		
t _{PLH}	Propagation Delay I _n to O _n	3.3 5.0	4.0 3.0		12.5 8.5	3.0 2.5	13.5 9.5	ns	3-5
t _{PHL}	Propagation Delay I _n to O _n	3.3 5.0	4.0 3.0		12.5 8.5	3.0 2.5	13.5 9.5	ns	3-5
t _{PLH}	Propagation Delay S _n to O _n	3.3 5.0	5.0 3.5		15.5 11.0	4.0 2.5	17.5 12.0	ns	3-6
t _{PHL}	Propagation Delay S _n to O _n	3.3 5.0	5.0 3.5		15.5 11.0	4.5 3.0	17.5 12.0	ns	3-6
t _{PZH}	Output Enable to O _n	3.3 5.0	3.5 2.5		8.5 6.0	3.0 2.0	9.0 6.5	ns	3-7
t _{PZL}	Output Enable to O _n	3.3 5.0	3.5 2.5		11.0 7.5	2.5 2.0	12.0 8.0	ns	3-8
t _{PHZ}	Output Enable to O _n	3.3 5.0	5.0 4.5		9.5 8.0	4.5 4.0	10.0 8.5	ns	3-7
t _{PLZ}	Output Enable to O _n	3.3 5.0	3.0 2.5		6.5 6.0	2.5 2.0	7.0 6.5	ns	3-8

* Voltage Range 3.3 V is 3.3 V ±0.3 V.
Voltage Range 5.0 V is 5.0 V ±0.5 V.

MC74AC350 MC74ACT350

DC CHARACTERISTICS

Symbol	Parameter	V _{CC} (V)	74ACT		74ACT		Unit	Conditions
			T _A = +25°C		T _A = -40°C to +85°C			
			Typ	Guaranteed Limits				
V _{IH}	Minimum High Level Input Voltage	4.5	1.5	2.0	2.0	V	V _{OUT} = 0.1 V or V _{CC} - 0.1 V	
		5.5	1.5	2.0	2.0			
V _{IL}	Maximum Low Level Input Voltage	4.5	1.5	0.8	0.8	V	V _{OUT} = 0.1 V or V _{CC} - 0.1 V	
		5.5	1.5	0.8	0.8			
V _{OH}	Minimum High Level Output Voltage	4.5	4.49	4.4	4.4	V	I _{OUT} = -50 μA	
		5.5	5.49	5.4	5.4			
		4.5		3.86	3.76	V	*V _{IN} = V _{IL} or V _{IH} -24 mA I _{OH} = -24 mA	
		5.5		4.86	4.76			
V _{OL}	Maximum Low Level Output Voltage	4.5	0.001	0.1	0.1	V	I _{OUT} = 50 μA	
		5.5	0.001	0.1	0.1			
		4.5		0.36	0.44	V	*V _{IN} = V _{IL} or V _{IH} 24 mA I _{OL} = 24 mA	
		5.5		0.36	0.44			
I _{IN}	Maximum Input Leakage Current	5.5		±0.1	±1.0	μA	V _I = V _{CC} , GND	
ΔI _{CC} T	Additional Max. I _{CC} /Input	5.5	0.6		1.5	mA	V _I = V _{CC} - 2.1 V	
I _{OZ}	Maximum 3-State Current	5.5		±0.5	±5.0	μA	V _I (OE) = V _{IL} , V _{IH} V _I = V _{CC} , GND V _O = V _{CC} , GND	
I _{OLD}	†Minimum Dynamic Output Current	5.5			75	mA	V _{OLD} = 1.65 V Max	
I _{OHD}		5.5			-75	mA	V _{OHD} = 3.85 V Min	
I _{CC}	Maximum Quiescent Supply Current	5.5		8.0	80	μA	V _{IN} = V _{CC} or GND	

* All outputs loaded; thresholds on input associated with output under test.

† Maximum test duration 2.0 ms, one output loaded at a time.

MC74AC350 MC74ACT350

AC CHARACTERISTICS (For Figures and Waveforms — See Section 3)

Symbol	Parameter	V _{CC} * (V)	74ACT			74ACT		Unit	Fig. No.
			T _A = +25°C C _L = 50 pF			T _A = -40°C to +85°C C _L = 50 pF			
			Min	Typ	Max	Min	Max		
t _{PLH}	Propagation Delay I _n to O _n	5.0	4.0		11.5	3.0	13.5	ns	3-6
t _{PHL}	Propagation Delay I _n to O _n	5.0	4.0		11.5	3.0	13.5	ns	3-6
t _{PLH}	Propagation Delay S _n to O _n	5.0	4.5		13.0	3.5	15.5	ns	3-6
t _{PHL}	Propagation Delay S _n to O _n	5.0	4.5		13.0	3.5	15.5	ns	3-6
t _{PZH}	Output Enable to O _n	5.0	4.0		9.0	3.0	10.0	ns	3-7
t _{PZL}	Output Enable to O _n	5.0	4.0		10.0	3.0	11.5	ns	3-8
t _{PHZ}	Output Enable to O _n	5.0	4.0		10.0	3.0	11.0	ns	3-7
t _{PLZ}	Output Enable to O _n	5.0	4.0		8.0	3.0	9.0	ns	3-8

* Voltage Range 5.0 V is 5.0 V ±0.5 V.

CAPACITANCE

Symbol	Parameter	Value Typ	Unit	Test Conditions
C _{IN}	Input Capacitance	4.5	pF	V _{CC} = 5.0 V
C _{PD}	Power Dissipation Capacitance	40.0	pF	V _{CC} = 5.0 V

MC74AC350 MC74ACT350

OUTLINE DIMENSIONS

N SUFFIX PLASTIC DIP PACKAGE CASE 648-08 ISSUE R

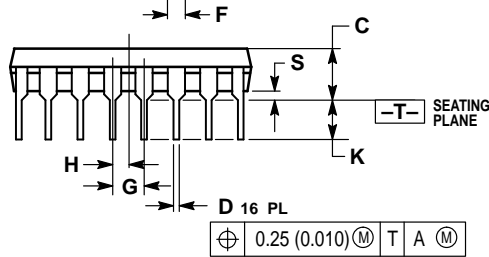
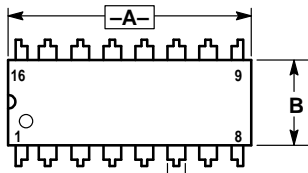

NOTES:

1. DIMENSIONING AND TOLERANCING PER ANSI Y14.5M, 1982.
2. CONTROLLING DIMENSION: INCH.
3. DIMENSION L TO CENTER OF LEADS WHEN FORMED PARALLEL.
4. DIMENSION B DOES NOT INCLUDE MOLD FLASH.
5. ROUNDED CORNERS OPTIONAL.

DIM	INCHES		MILLIMETERS	
	MIN	MAX	MIN	MAX
A	0.740	0.770	18.80	19.55
B	0.250	0.270	6.35	6.85
C	0.145	0.175	3.69	4.44
D	0.015	0.021	0.39	0.53
F	0.040	0.70	1.02	1.77
G	0.100 BSC		2.54 BSC	
H	0.050 BSC		1.27 BSC	
J	0.008	0.015	0.21	0.38
K	0.110	0.130	2.80	3.30
L	0.295	0.305	7.50	7.74
M	0°	10°	0°	10°
S	0.020	0.040	0.51	1.01

D SUFFIX PLASTIC SOIC PACKAGE CASE 751B-05 ISSUE J

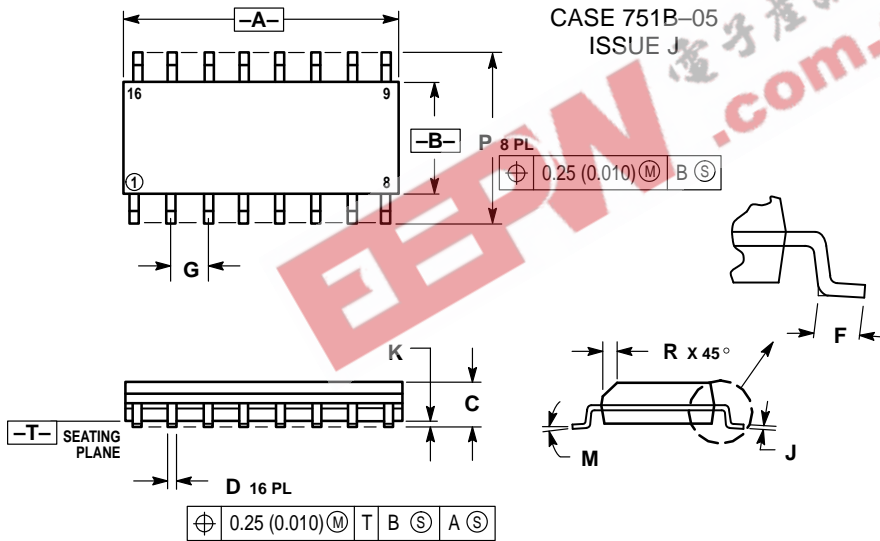

NOTES:

1. DIMENSIONING AND TOLERANCING PER ANSI Y14.5M, 1982.
2. CONTROLLING DIMENSION: MILLIMETER.
3. DIMENSIONS A AND B DO NOT INCLUDE MOLD PROTRUSION.
4. MAXIMUM MOLD PROTRUSION 0.15 (0.006) PER SIDE.
5. DIMENSION D DOES NOT INCLUDE DAMBAR PROTRUSION. ALLOWABLE DAMBAR PROTRUSION SHALL BE 0.127 (0.005) TOTAL IN EXCESS OF THE D DIMENSION AT MAXIMUM MATERIAL CONDITION.

DIM	MILLIMETERS		INCHES	
	MIN	MAX	MIN	MAX
A	9.80	10.00	0.386	0.393
B	3.80	4.00	0.150	0.157
C	1.35	1.75	0.054	0.068
D	0.35	0.49	0.014	0.019
F	0.40	1.25	0.016	0.049
G	1.27 BSC		0.050 BSC	
J	0.19	0.25	0.008	0.009
K	0.10	0.25	0.004	0.009
M	0°	7°	0°	7°
P	5.80	6.20	0.229	0.244
R	0.25	0.50	0.010	0.019

Motorola reserves the right to make changes without further notice to any products herein. Motorola makes no warranty, representation or guarantee regarding the suitability of its products for any particular purpose, nor does Motorola assume any liability arising out of the application or use of any product or circuit, and specifically disclaims any and all liability, including without limitation consequential or incidental damages. "Typical" parameters can and do vary in different applications. All operating parameters, including "Typicals" must be validated for each customer application by customer's technical experts. Motorola does not convey any license under its patent rights nor the rights of others. Motorola products are not designed, intended, or authorized for use as components in systems intended for surgical implant into the body, or other applications intended to support or sustain life, or for any other application in which the failure of the Motorola product could create a situation where personal injury or death may occur. Should Buyer purchase or use Motorola products for any such unintended or unauthorized application, Buyer shall indemnify and hold Motorola and its officers, employees, subsidiaries, affiliates, and distributors harmless against all claims, costs, damages, and expenses, and reasonable attorney fees arising out of, directly or indirectly, any claim of personal injury or death associated with such unintended or unauthorized use, even if such claim alleges that Motorola was negligent regarding the design or manufacture of the part. Motorola and  are registered trademarks of Motorola, Inc. Motorola, Inc. is an Equal Opportunity/Affirmative Action Employer.

How to reach us:

USA/EUROPE: Motorola Literature Distribution;
P.O. Box 20912; Phoenix, Arizona 85036. 1-800-441-2447

JAPAN: Nippon Motorola Ltd.; Tatsumi-SPD-JLDC, Toshikatsu Otsuki,
6F Seibu-Butsuryu-Center, 3-14-2 Tatsumi Koto-Ku, Tokyo 135, Japan. 03-3521-8315

MFAX: RMFAX0@email.sps.mot.com - TOUCHTONE (602) 244-6609
INTERNET: http://Design-NET.com

HONG KONG: Motorola Semiconductors H.K. Ltd.; 8B Tai Ping Industrial Park,
51 Ting Kok Road, Tai Po, N.T., Hong Kong. 852-26629298



MC74AC350/D

