

**LM7805 • LM7806 • LM7808 • LM7809 •
LM7810 • LM7812 • LM7815 • LM7818 • LM7824 •
LM7805A • LM7806A • LM7808A • LM7809A •
LM7810A • LM7812A • LM7815A • LM7818A • LM7824A**

3-Terminal 1A Positive Voltage Regulator

General Description

The LM78XX series of three terminal positive regulators are available in the TO-220 package and with several fixed output voltages, making them useful in a wide range of applications. Each type employs internal current limiting, thermal shut down and safe operating area protection, making it essentially indestructible. If adequate heat sinking is provided, they can deliver over 1A output current. Although designed primarily as fixed voltage regulators, these devices can be used with external components to obtain adjustable voltages and currents.

Features

- Output Current up to 1A
- Output Voltages of 5, 6, 8, 9, 12, 15, 18, 24
- Thermal Overload Protection
- Short Circuit Protection
- Output Transistor Safe Operating Area Protection

Ordering Code:

Product Number	Output Voltage Tolerance	Package	Operating Temperature	
LM7805CT	±4%	TO-220	-40°C - +125°C	
LM7806CT				
LM7808CT				
LM7809CT				
LM7810CT				
LM7812CT				
LM7815CT				
LM7818CT				
LM7824CT				
LM7805ACT	±2%		TO-220	0°C - +125°C
LM7806ACT				
LM7808ACT				
LM7809ACT				
LM7810ACT				
LM7812ACT				
LM7815ACT				
LM7818ACT				
LM7824ACT				

LM7805 • LM7806 • LM7808 • LM7809 • LM7810 • LM7812 • LM7815 • LM7818 • LM7824 • LM7805A • LM7806A • LM7808A • LM7809A • LM7810A • LM7812A • LM7815A • LM7818A • LM7824A 3-Terminal 1A Positive Voltage Regulator

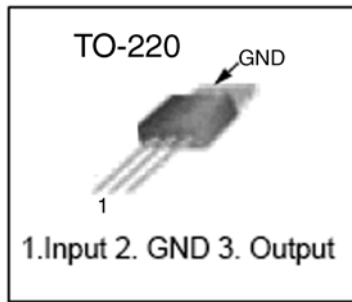

Internal Block Diagram

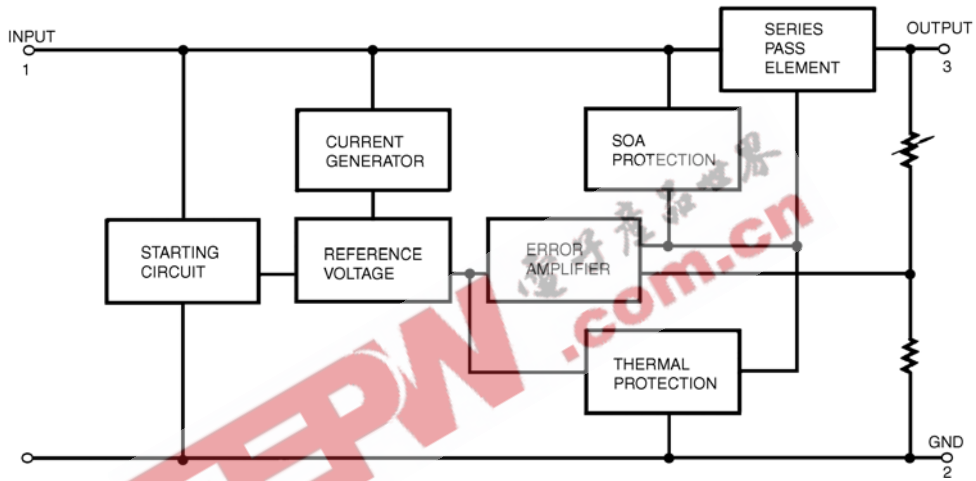

Absolute Maximum Ratings (Note 1)

Parameter	Symbol	Value	Unit
Input Voltage (for $V_O = 5V$ to $18V$)	V_I	35	V
(for $V_O = 24V$)	V_I	40	V
Thermal Resistance Junction-Cases (TO-220)	$R_{\theta JC}$	5	$^{\circ}C/W$
Thermal Resistance Junction-Air (TO-220)	$R_{\theta JA}$	65	$^{\circ}C/W$
Operating Temperature Range	T_{OPR}	0 ~ +125	$^{\circ}C$
LM78xx		-40 ~ +125	$^{\circ}C$
LM78xxA		0 ~ +125	$^{\circ}C$
Storage Temperature Range	T_{STG}	-65 ~ +150	$^{\circ}C$

Note 1: Absolute maximum ratings are those values beyond which damage to the device may occur. The datasheet specifications should be met, without exception, to ensure that the system design is reliable over its power supply, temperature, and output/input loading variables. Fairchild does not recommend operation outside datasheet specifications.

Electrical Characteristics (LM7805)

(Refer to the test circuits. $-40^{\circ}C < T_J < 125^{\circ}C$, $I_O = 500mA$, $V_I = 10V$, $C_I = 0.1\mu F$, unless otherwise specified)

Parameter	Symbol	Conditions	Min	Typ	Max	Unit	
Output Voltage	V_O	$T_J = +25^{\circ}C$	4.8	5.0	5.2	V	
		$5mA \leq I_O \leq 1A$, $P_O \leq 15W$, $V_I = 7V$ to $20V$	4.75	5.0	5.25		
Line Regulation (Note 2)	Regline	$T_J = +25^{\circ}C$	$V_O = 7V$ to $25V$	-	4.0	100	mV
			$V_I = 8V$ to $12V$	-	1.6	50.0	
Load Regulation	Regload	$T_J = +25^{\circ}C$	$I_O = 5mA$ to $1.5mA$	-	9.0	100	mV
			$I_O = 250mA$ to $750mA$	-	4.0	50.0	
Quiescent Current	I_Q	$T_J = +25^{\circ}C$	-	5.0	8.0	mA	
Quiescent Current Change	ΔI_Q	$I_O = 5mA$ to $1A$	$V_I = 7V$ to $25V$	-	0.03	0.5	mA
				-	0.3	1.3	
Output Voltage Drift (Note 3)	$\Delta V_O / \Delta T$	$I_O = 5mA$	-	-0.8	-	$mV/^{\circ}C$	
Output Noise Voltage	V_N	$f = 10Hz$ to $100KHz$, $T_A = +25^{\circ}C$	-	42.0	-	$\mu V/V_O$	
Ripple Rejection (Note 3)	RR	$f = 120Hz$, $V_O = 8V$ to $18V$	62.0	73.0	-	dB	
Dropout Voltage	V_{DROP}	$I_O = 1A$, $T_J = +25^{\circ}C$	-	2.0	-	V	
Output Resistance (Note 3)	r_O	$f = 1KHz$	-	15.0	-	$m\Omega$	
Short Circuit Current	I_{SC}	$V_I = 35V$, $T_A = +25^{\circ}C$	-	230	-	mA	
Peak Current (Note 3)	I_{PK}	$T_J = +25^{\circ}C$	-	2.2	-	A	

Note 2: Load and line regulation are specified at constant junction temperature. Changes in V_O due to heating effects must be taken into account separately. Pulse testing with low duty is used.

Note 3: These parameters, although guaranteed, are not 100% tested in production.

Electrical Characteristics (LM7809)

(Refer to the test circuits. $-40^{\circ}\text{C} < T_J < 125^{\circ}\text{C}$, $I_O = 500\text{mA}$, $V_I = 15\text{V}$, $C_I = 0.33\mu\text{F}$, $C_O = 0.1\mu\text{F}$, unless otherwise specified)

Parameter	Symbol	Conditions	Min	Typ	Max	Unit	
Output Voltage	V_O	$T_J = +25^{\circ}\text{C}$	8.65	9.0	9.35	V	
		$5\text{mA} \leq I_O \leq 1\text{A}$, $P_O \leq 15\text{W}$, $V_I = 11.5\text{V to } 24\text{V}$	8.6	9.0	9.4		
Line Regulation (Note 8)	Regline	$T_J = +25^{\circ}\text{C}$	$V_I = 11.5\text{V to } 25\text{V}$	–	6.0	180	mV
			$V_I = 12\text{V to } 17\text{V}$	–	2.0	90.0	
Load Regulation (Note 8)	Regload	$T_J = +25^{\circ}\text{C}$	$I_O = 5\text{mA to } 1.5\text{mA}$	–	12.0	180	mV
			$I_O = 250\text{mA to } 750\text{mA}$	–	4.0	90.0	
Quiescent Current	I_Q	$T_J = +25^{\circ}\text{C}$	–	5.0	8.0	mA	
Quiescent Current Change	ΔI_Q	$I_O = 5\text{mA to } 1\text{A}$	–	–	0.5	mA	
		$V_I = 11.5\text{V to } 26\text{V}$	–	–	1.3		
Output Voltage Drift (Note 9)	$\Delta V_O / \Delta T$	$I_O = 5\text{mA}$	–	–1.0	–	mV/°C	
Output Noise Voltage	V_N	$f = 10\text{Hz to } 100\text{kHz}$, $T_A = +25^{\circ}\text{C}$	–	58.0	–	$\mu\text{V}/V_O$	
Ripple Rejection (Note 9)	RR	$f = 120\text{Hz}$, $V_O = 13\text{V to } 23\text{V}$	56.0	71.0	–	dB	
Dropout Voltage	V_{DROP}	$I_O = 1\text{A}$, $T_J = +25^{\circ}\text{C}$	–	2.0	–	V	
Output Resistance (Note 9)	r_O	$f = 1\text{kHz}$	–	17.0	–	$\text{m}\Omega$	
Short Circuit Current	I_{SC}	$V_I = 35\text{V}$, $T_A = +25^{\circ}\text{C}$	–	250	–	mA	
Peak Current (Note 9)	I_{PK}	$T_J = +25^{\circ}\text{C}$	–	2.2	–	A	

Note 8: Load and line regulation are specified at constant junction temperature. Changes in V_O due to heating effects must be taken into account separately. Pulse testing with low duty is used.

Note 9: These parameters, although guaranteed, are not 100% tested in production.

Electrical Characteristics (LM7810)

(Refer to the test circuits. $-40^{\circ}\text{C} < T_J < 125^{\circ}\text{C}$, $I_O = 500\text{mA}$, $V_I = 16\text{V}$, $C_I = 0.33\mu\text{F}$, $C_O = 0.1\mu\text{F}$, unless otherwise specified)

Parameter	Symbol	Conditions	Min	Typ	Max	Unit	
Output Voltage	V_O	$T_J = +25^{\circ}\text{C}$	9.6	10.0	10.4	V	
		$5\text{mA} \leq I_O \leq 1\text{A}$, $P_O \leq 15\text{W}$, $V_I = 12.5\text{V to } 25\text{V}$	9.5	10.0	10.5		
Line Regulation (Note 10)	Regline	$T_J = +25^{\circ}\text{C}$	$V_I = 12.5\text{V to } 25\text{V}$	–	10.0	200	mV
			$V_I = 13\text{V to } 25\text{V}$	–	3.0	100	
Load Regulation (Note 10)	Regload	$T_J = +25^{\circ}\text{C}$	$I_O = 5\text{mA to } 1.5\text{mA}$	–	12.0	200	mV
			$I_O = 250\text{mA to } 750\text{mA}$	–	4.0	400	
Quiescent Current	I_Q	$T_J = +25^{\circ}\text{C}$	–	5.1	8.0	mA	
Quiescent Current Change	ΔI_Q	$I_O = 5\text{mA to } 1\text{A}$	–	–	0.5	mA	
		$V_I = 12.5\text{V to } 29\text{V}$	–	–	1.0		
Output Voltage Drift (Note 11)	$\Delta V_O / \Delta T$	$I_O = 5\text{mA}$	–	–1.0	–	mV/°C	
Output Noise Voltage	V_N	$f = 10\text{Hz to } 100\text{kHz}$, $T_A = +25^{\circ}\text{C}$	–	58.0	–	$\mu\text{V}/V_O$	
Ripple Rejection (Note 11)	RR	$f = 120\text{Hz}$, $V_O = 13\text{V to } 23\text{V}$	56.0	71.0	–	dB	
Dropout Voltage	V_{DROP}	$I_O = 1\text{A}$, $T_J = +25^{\circ}\text{C}$	–	2.0	–	V	
Output Resistance (Note 11)	r_O	$f = 1\text{kHz}$	–	17.0	–	$\text{m}\Omega$	
Short Circuit Current	I_{SC}	$V_I = 35\text{V}$, $T_A = +25^{\circ}\text{C}$	–	250	–	mA	
Peak Current (Note 11)	I_{PK}	$T_J = +25^{\circ}\text{C}$	–	2.2	–	A	

Note 10: Load and line regulation are specified at constant junction temperature. Changes in V_O due to heating effects must be taken into account separately. Pulse testing with low duty is used.

Note 11: These parameters, although guaranteed, are not 100% tested in production.

Electrical Characteristics (LM7812)

(Refer to the test circuits. $-40^{\circ}\text{C} < T_J < 125^{\circ}\text{C}$, $I_O = 500\text{mA}$, $V_I = 19\text{V}$, $C_I = 0.33\mu\text{F}$, $C_O = 0.1\mu\text{F}$, unless otherwise specified)

Parameter	Symbol	Conditions	Min	Typ	Max	Unit	
Output Voltage	V_O	$T_J = +25^{\circ}\text{C}$	11.5	12.0	12.5	V	
		$5\text{mA} \leq I_O \leq 1\text{A}$, $P_O \leq 15\text{W}$, $V_I = 14.5\text{V to } 27\text{V}$	11.4	12.0	12.6		
Line Regulation (Note 12)	Regline	$T_J = +25^{\circ}\text{C}$	$V_I = 14.5\text{V to } 30\text{V}$	–	10.0	240	mV
			$V_I = 16\text{V to } 22\text{V}$	–	3.0	120	
Load Regulation (Note 12)	Regload	$T_J = +25^{\circ}\text{C}$	$I_O = 5\text{mA to } 1.5\text{mA}$	–	11.0	240	mV
			$I_O = 250\text{mA to } 750\text{mA}$	–	5.0	120	
Quiescent Current	I_Q	$T_J = +25^{\circ}\text{C}$	–	5.1	8.0	mA	
Quiescent Current Change	ΔI_Q	$I_O = 5\text{mA to } 1\text{A}$	–	0.1	0.5	mA	
		$V_I = 14.5\text{V to } 30\text{V}$	–	0.5	1.0		
Output Voltage Drift (Note 13)	$\Delta V_O / \Delta T$	$I_O = 5\text{mA}$	–	–1.0	–	mV/ $^{\circ}\text{C}$	
Output Noise Voltage	V_N	$f = 10\text{Hz to } 100\text{KHz}$, $T_A = +25^{\circ}\text{C}$	–	76.0	–	$\mu\text{V}/V_O$	
Ripple Rejection (Note 13)	RR	$f = 120\text{Hz}$, $V_I = 15\text{V to } 25\text{V}$	55.0	71.0	–	dB	
Dropout Voltage	V_{DROPP}	$I_O = 1\text{A}$, $T_J = +25^{\circ}\text{C}$	–	2.0	–	V	
Output Resistance (Note 13)	r_O	$f = 1\text{KHz}$	–	18.0	–	$\text{m}\Omega$	
Short Circuit Current	I_{SC}	$V_I = 35\text{V}$, $T_A = +25^{\circ}\text{C}$	–	230	–	mA	
Peak Current (Note 13)	I_{PK}	$T_J = +25^{\circ}\text{C}$	–	2.2	–	A	

Note 12: Load and line regulation are specified at constant junction temperature. Changes in V_O due to heating effects must be taken into account separately. Pulse testing with low duty is used.

Note 13: These parameters, although guaranteed, are not 100% tested in production.

Electrical Characteristics (LM7815)

(Refer to the test circuits. $-40^{\circ}\text{C} < T_J < 125^{\circ}\text{C}$, $I_O = 500\text{mA}$, $V_I = 23\text{V}$, $C_I = 0.33\mu\text{F}$, $C_O = 0.1\mu\text{F}$, unless otherwise specified)

Parameter	Symbol	Conditions	Min	Typ	Max	Unit	
Output Voltage	V_O	$T_J = +25^{\circ}\text{C}$	14.4	15.0	15.6	V	
		$5\text{mA} \leq I_O \leq 1\text{A}$, $P_O \leq 15\text{W}$, $V_I = 17.5\text{V to } 30\text{V}$	14.25	15.0	15.75		
Line Regulation (Note 14)	Regline	$T_J = +25^{\circ}\text{C}$	$V_I = 17.5\text{V to } 30\text{V}$	–	11.0	300	mV
			$V_I = 20\text{V to } 26\text{V}$	–	3.0	150	
Load Regulation (Note 14)	Regload	$T_J = +25^{\circ}\text{C}$	$I_O = 5\text{mA to } 1.5\text{mA}$	–	12.0	300	mV
			$I_O = 250\text{mA to } 750\text{mA}$	–	4.0	150	
Quiescent Current	I_Q	$T_J = +25^{\circ}\text{C}$	–	5.2	8.0	mA	
Quiescent Current Change	ΔI_Q	$I_O = 5\text{mA to } 1\text{A}$	–	–	0.5	mA	
		$V_I = 17.5\text{V to } 30\text{V}$	–	–	1.0		
Output Voltage Drift (Note 15)	$\Delta V_O / \Delta T$	$I_O = 5\text{mA}$	–	–1.0	–	mV/ $^{\circ}\text{C}$	
Output Noise Voltage	V_N	$f = 10\text{Hz to } 100\text{KHz}$, $T_A = +25^{\circ}\text{C}$	–	90.0	–	$\mu\text{V}/V_O$	
Ripple Rejection (Note 15)	RR	$f = 120\text{Hz}$, $V_I = 18.5\text{V to } 28.5\text{V}$	54.0	70.0	–	dB	
Dropout Voltage	V_{DROPP}	$I_O = 1\text{A}$, $T_J = +25^{\circ}\text{C}$	–	2.0	–	V	
Output Resistance (Note 15)	r_O	$f = 1\text{KHz}$	–	19.0	–	$\text{m}\Omega$	
Short Circuit Current	I_{SC}	$V_I = 35\text{V}$, $T_A = +25^{\circ}\text{C}$	–	250	–	mA	
Peak Current (Note 15)	I_{PK}	$T_J = +25^{\circ}\text{C}$	–	2.2	–	A	

Note 14: Load and line regulation are specified at constant junction temperature. Changes in V_O due to heating effects must be taken into account separately. Pulse testing with low duty is used.

Note 15: These parameters, although guaranteed, are not 100% tested in production.

Electrical Characteristics (LM7818)

(Refer to the test circuits. $-40^{\circ}\text{C} < T_J < 125^{\circ}\text{C}$, $I_O = 500\text{mA}$, $V_I = 27\text{V}$, $C_I = 0.33\mu\text{F}$, $C_O = 0.1\mu\text{F}$, unless otherwise specified)

Parameter	Symbol	Conditions	Min	Typ	Max	Unit	
Output Voltage	V_O	$T_J = +25^{\circ}\text{C}$	17.3	18.0	18.7	V	
		$5\text{mA} \leq I_O \leq 1\text{A}$, $P_O \leq 15\text{W}$, $V_I = 21\text{V to } 33\text{V}$	17.1	18.0	18.9		
Line Regulation (Note 12)	Regline	$T_J = +25^{\circ}\text{C}$	$V_I = 21\text{V to } 33\text{V}$	–	15.0	360	mV
			$V_I = 24\text{V to } 30\text{V}$	–	5.0	180	
Load Regulation (Note 12)	Regload	$T_J = +25^{\circ}\text{C}$	$I_O = 5\text{mA to } 1.5\text{mA}$	–	15.0	360	mV
			$I_O = 250\text{mA to } 750\text{mA}$	–	5.0	180	
Quiescent Current	I_Q	$T_J = +25^{\circ}\text{C}$	–	5.2	8.0	mA	
Quiescent Current Change	ΔI_Q	$I_O = 5\text{mA to } 1\text{A}$	–	–	0.5	mA	
		$V_I = 21\text{V to } 33\text{V}$	–	–	1.0		
Output Voltage Drift (Note 17)	$\Delta V_O/\Delta T$	$I_O = 5\text{mA}$	–	–1.0	–	mV/ $^{\circ}\text{C}$	
Output Noise Voltage	V_N	$f = 10\text{Hz to } 100\text{kHz}$, $T_A = +25^{\circ}\text{C}$	–	110	–	$\mu\text{V}/V_O$	
Ripple Rejection (Note 17)	RR	$f = 120\text{Hz}$, $V_I = 22\text{V to } 32\text{V}$	53.0	69.0	–	dB	
Dropout Voltage	V_{DROP}	$I_O = 1\text{A}$, $T_J = +25^{\circ}\text{C}$	–	2.0	–	V	
Output Resistance (Note 17)	r_O	$f = 1\text{kHz}$	–	22.0	–	$\text{m}\Omega$	
Short Circuit Current	I_{SC}	$V_I = 35\text{V}$, $T_A = +25^{\circ}\text{C}$	–	250	–	mA	
Peak Current (Note 17)	I_{PK}	$T_J = +25^{\circ}\text{C}$	–	2.2	–	A	

Note 16: Load and line regulation are specified at constant junction temperature. Changes in V_O due to heating effects must be taken into account separately. Pulse testing with low duty is used.

Note 17: These parameters, although guaranteed, are not 100% tested in production.

Electrical Characteristics (LM7824)

(Refer to the test circuits. $-40^{\circ}\text{C} < T_J < 125^{\circ}\text{C}$, $I_O = 500\text{mA}$, $V_I = 33\text{V}$, $C_I = 0.33\mu\text{F}$, $C_O = 0.1\mu\text{F}$, unless otherwise specified)

Parameter	Symbol	Conditions	Min	Typ	Max	Unit	
Output Voltage	V_O	$T_J = +25^{\circ}\text{C}$	23.0	24.0	25.0	V	
		$5\text{mA} \leq I_O \leq 1\text{A}$, $P_O \leq 15\text{W}$, $V_I = 27\text{V to } 38\text{V}$	22.8	24.0	25.25		
Line Regulation (Note 18)	Regline	$T_J = +25^{\circ}\text{C}$	$V_I = 27\text{V to } 38\text{V}$	–	17.0	480	mV
			$V_I = 30\text{V to } 36\text{V}$	–	6.0	240	
Load Regulation (Note 18)	Regload	$T_J = +25^{\circ}\text{C}$	$I_O = 5\text{mA to } 1.5\text{mA}$	–	15.0	480	mV
			$I_O = 250\text{mA to } 750\text{mA}$	–	5.0	240	
Quiescent Current	I_Q	$T_J = +25^{\circ}\text{C}$	–	5.2	8.0	mA	
Quiescent Current Change	ΔI_Q	$I_O = 5\text{mA to } 1\text{A}$	–	0.1	0.5	mA	
		$V_I = 27\text{V to } 38\text{V}$	–	0.5	1.0		
Output Voltage Drift (Note 19)	$\Delta V_O/\Delta T$	$I_O = 5\text{mA}$	–	–1.5	–	mV/ $^{\circ}\text{C}$	
Output Noise Voltage	V_N	$f = 10\text{Hz to } 100\text{kHz}$, $T_A = +25^{\circ}\text{C}$	–	60.0	–	$\mu\text{V}/V_O$	
Ripple Rejection (Note 19)	RR	$f = 120\text{Hz}$, $V_I = 28\text{V to } 38\text{V}$	50.0	67.0	–	dB	
Dropout Voltage	V_{DROP}	$I_O = 1\text{A}$, $T_J = +25^{\circ}\text{C}$	–	2.0	–	V	
Output Resistance (Note 19)	r_O	$f = 1\text{kHz}$	–	28.0	–	$\text{m}\Omega$	
Short Circuit Current	I_{SC}	$V_I = 35\text{V}$, $T_A = +25^{\circ}\text{C}$	–	230	–	mA	
Peak Current (Note 19)	I_{PK}	$T_J = +25^{\circ}\text{C}$	–	2.2	–	A	

Note 18: Load and line regulation are specified at constant junction temperature. Changes in V_O due to heating effects must be taken into account separately. Pulse testing with low duty is used.

Note 19: These parameters, although guaranteed, are not 100% tested in production.

Electrical Characteristics (LM7805A)

(Refer to the test circuits. $0^{\circ}\text{C} < T_J < 125^{\circ}\text{C}$, $I_O = 1\text{A}$, $V_I = 10\text{V}$, $C_I = 0.33\mu\text{F}$, $C_O = 0.1\mu\text{F}$, unless otherwise specified)

Parameter	Symbol	Conditions	Min	Typ	Max	Unit	
Output Voltage	V_O	$T_J = +25^{\circ}\text{C}$	4.9	5.0	5.1	V	
		$I_O = 5\text{mA to } 1\text{A}$, $P_O \leq 15\text{W}$, $V_I = 7.5\text{V to } 20\text{V}$	4.8	5.0'	5.2		
Line Regulation (Note 20)	Regline	$V_I = 7.5\text{V to } 25\text{V}$, $I_O = 500\text{mA}$	–	5.0	50.0	mV	
		$V_I = 8\text{V to } 12\text{V}$	–	3.0	50.0		
		$T_J = +25^{\circ}\text{C}$	$V_I = 7.3\text{V to } 20\text{V}$	–	5.0		50.0
		$V_I = 8\text{V to } 12\text{V}$	–	1.5	25.0		
Load Regulation (Note 20)	Regload	$T_J = +25^{\circ}\text{C}$, $I_O = 5\text{mA to } 1.5\text{mA}$	–	9.0	100	mV	
		$I_O = 5\text{mA to } 1\text{mA}$	–	9.0	100		
		$I_O = 250\text{mA to } 750\text{mA}$	–	4.0	50.0		
Quiescent Current	I_Q	$T_J = +25^{\circ}\text{C}$	–	5.0	6.0	mA	
Quiescent Current Change	ΔI_Q	$I_O = 5\text{mA to } 1\text{A}$	–	–	0.5	mA	
		$V_I = 8\text{V to } 25\text{V}$, $I_O = 500\text{mA}$	–	–	0.8		
		$V_I = 7.5\text{V to } 20\text{V}$, $T_J = +25^{\circ}\text{C}$	–	–	0.8		
Output Voltage Drift (Note 21)	$\Delta V_O / \Delta T$	$I_O = 5\text{mA}$	–	–0.8	–	mV/ $^{\circ}\text{C}$	
Output Noise Voltage	V_N	$f = 10\text{Hz to } 100\text{kHz}$, $T_A = +25^{\circ}\text{C}$	–	10.0	–	$\mu\text{V}/V_O$	
Ripple Rejection (Note 21)	RR	$f = 120\text{Hz}$, $I_O = 500\text{mA}$, $V_I = 8\text{V to } 18\text{V}$	–	68.0	–	dB	
Dropout Voltage	V_{DROP}	$I_O = 1\text{A}$, $T_J = +25^{\circ}\text{C}$	–	2.0	–	V	
Output Resistance (Note 21)	r_O	$f = 1\text{kHz}$	–	17.0	–	$\text{m}\Omega$	
Short Circuit Current	I_{SC}	$V_I = 35\text{V}$, $T_A = +25^{\circ}\text{C}$	–	250	–	mA	
Peak Current (Note 21)	I_{PK}	$T_J = +25^{\circ}\text{C}$	–	2.2	–	A	

Note 20: Load and line regulation are specified at constant junction temperature. Changes in V_O due to heating effects must be taken into account separately. Pulse testing with low duty is used.

Note 21: These parameters, although guaranteed, are not 100% tested in production.

Electrical Characteristics (LM7806A)

(Refer to the test circuits. $0^{\circ}\text{C} < T_J < 125^{\circ}\text{C}$, $I_O = 1\text{A}$, $V_I = 11\text{V}$, $C_I = 0.33\mu\text{F}$, $C_O = 0.1\mu\text{F}$, unless otherwise specified)

Parameter	Symbol	Conditions	Min	Typ	Max	Unit	
Output Voltage	V_O	$T_J = +25^{\circ}\text{C}$	5.58	6.0	6.12	V	
		$I_O = 5\text{mA to } 1\text{A}$, $P_O \leq 15\text{W}$, $V_I = 8.6\text{V to } 21\text{V}$	5.76	6.0	6.24		
Line Regulation (Note 22)	Regline	$V_I = 8.6\text{V to } 25\text{V}$, $I_O = 500\text{mA}$	–	5.0	60.0	mV	
		$V_I = 9\text{V to } 13\text{V}$	–	3.0	60.0		
		$T_J = +25^{\circ}\text{C}$	$V_I = 8.3\text{V to } 21\text{V}$	–	5.0		60.0
			$V_I = 9\text{V to } 13\text{V}$	–	1.5		30.0
Load Regulation (Note 22)	Regload	$T_J = +25^{\circ}\text{C}$, $I_O = 5\text{mA to } 1.5\text{mA}$	–	9.0	100	mV	
		$I_O = 5\text{mA to } 1\text{mA}$	–	4.0	100		
		$I_O = 250\text{mA to } 750\text{mA}$	–	5.0	50.0		
Quiescent Current	I_Q	$T_J = +25^{\circ}\text{C}$	–	4.3	6.0	mA	
Quiescent Current Change	ΔI_Q	$I_O = 5\text{mA to } 1\text{A}$	–	–	0.5	mA	
		$V_I = 19\text{V to } 25\text{V}$, $I_O = 500\text{mA}$	–	–	0.8		
		$V_I = 8.5\text{V to } 21\text{V}$, $T_J = +25^{\circ}\text{C}$	–	–	0.8		
Output Voltage Drift (Note 23)	$\Delta V_O/\Delta T$	$I_O = 5\text{mA}$	–	–0.8	–	mV/ $^{\circ}\text{C}$	
Output Noise Voltage	V_N	$f = 10\text{Hz to } 100\text{kHz}$, $T_A = +25^{\circ}\text{C}$	–	10.0	–	$\mu\text{V}/V_O$	
Ripple Rejection (Note 23)	RR	$f = 120\text{Hz}$, $I_O = 500\text{mA}$, $V_I = 9\text{V to } 19\text{V}$	–	65.0	–	dB	
Dropout Voltage	V_{DROP}	$I_O = 1\text{A}$, $T_J = +25^{\circ}\text{C}$	–	2.0	–	V	
Output Resistance (Note 23)	r_O	$f = 1\text{kHz}$	–	17.0	–	$\text{m}\Omega$	
Short Circuit Current	I_{SC}	$V_I = 35\text{V}$, $T_A = +25^{\circ}\text{C}$	–	250	–	mA	
Peak Current (Note 23)	I_{PK}	$T_J = +25^{\circ}\text{C}$	–	2.2	–	A	

Note 22: Load and line regulation are specified at constant junction temperature. Changes in V_O due to heating effects must be taken into account separately. Pulse testing with low duty is used.

Note 23: These parameters, although guaranteed, are not 100% tested in production.

Electrical Characteristics (LM7808A)

(Refer to the test circuits. $0^{\circ}\text{C} < T_J < 125^{\circ}\text{C}$, $I_O = 1\text{A}$, $V_I = 14\text{V}$, $C_I = 0.33\mu\text{F}$, $C_O = 0.1\mu\text{F}$, unless otherwise specified)

Parameter	Symbol	Conditions	Min	Typ	Max	Unit	
Output Voltage	V_O	$T_J = +25^{\circ}\text{C}$	7.84	8.0	8.16	V	
		$I_O = 5\text{mA to } 1\text{A}$, $P_O \leq 15\text{W}$, $V_I = 10.6\text{V to } 23\text{V}$	7.7	8.0	8.3		
Line Regulation (Note 24)	Regline	$V_I = 10.6\text{V to } 25\text{V}$, $I_O = 500\text{mA}$	–	6.0	80.0	mV	
		$V_I = 11\text{V to } 17\text{V}$	–	3.0	80.0		
		$T_J = +25^{\circ}\text{C}$	$V_I = 10.4\text{V to } 23\text{V}$	–	6.0		80.0
			$V_I = 11\text{V to } 17\text{V}$	–	2.0		40.0
Load Regulation (Note 24)	Regload	$T_J = +25^{\circ}\text{C}$, $I_O = 5\text{mA to } 1.5\text{mA}$	–	12.0	100	mV	
		$I_O = 5\text{mA to } 1\text{mA}$	–	12.0	100		
		$I_O = 250\text{mA to } 750\text{mA}$	–	5.0	50.0		
Quiescent Current	I_Q	$T_J = +25^{\circ}\text{C}$	–	5.0	6.0	mA	
Quiescent Current Change	ΔI_Q	$I_O = 5\text{mA to } 1\text{A}$	–	–	0.5	mA	
		$V_I = 11\text{V to } 25\text{V}$, $I_O = 500\text{mA}$	–	–	0.8		
		$V_I = 10.6\text{V to } 23\text{V}$, $T_J = +25^{\circ}\text{C}$	–	–	0.8		
Output Voltage Drift (Note 25)	$\Delta V_O/\Delta T$	$I_O = 5\text{mA}$	–	–0.8	–	mV/ $^{\circ}\text{C}$	
Output Noise Voltage	V_N	$f = 10\text{Hz to } 100\text{kHz}$, $T_A = +25^{\circ}\text{C}$	–	10.0	–	$\mu\text{V}/V_O$	
Ripple Rejection (Note 25)	RR	$f = 120\text{Hz}$, $I_O = 500\text{mA}$, $V_I = 11.5\text{V to } 21.5\text{V}$	–	62.0	–	dB	
Dropout Voltage	V_{DROP}	$I_O = 1\text{A}$, $T_J = +25^{\circ}\text{C}$	–	2.0	–	V	
Output Resistance (Note 25)	r_O	$f = 1\text{kHz}$	–	18.0	–	$\text{m}\Omega$	
Short Circuit Current	I_{SC}	$V_I = 35\text{V}$, $T_A = +25^{\circ}\text{C}$	–	250	–	mA	
Peak Current (Note 25)	I_{PK}	$T_J = +25^{\circ}\text{C}$	–	2.2	–	A	

Note 24: Load and line regulation are specified at constant junction temperature. Changes in V_O due to heating effects must be taken into account separately. Pulse testing with low duty is used.

Note 25: These parameters, although guaranteed, are not 100% tested in production.

Electrical Characteristics (LM7809A)

(Refer to the test circuits. $0^{\circ}\text{C} < T_J < 125^{\circ}\text{C}$, $I_O = 1\text{A}$, $V_I = 15\text{V}$, $C_I = 0.33\mu\text{F}$, $C_O = 0.1\mu\text{F}$, unless otherwise specified)

Parameter	Symbol	Conditions	Min	Typ	Max	Units	
Output Voltage	V_O	$T_J = +25^{\circ}\text{C}$	8.82	9.0	9.16	V	
		$I_O = 5\text{mA to } 1\text{A}$, $P_O \leq 15\text{W}$, $V_I = 11.2\text{V to } 24\text{V}$	8.65	9.0	9.35		
Line Regulation (Note 26)	Regline	$V_I = 11.7\text{V to } 25\text{V}$, $I_O = 500\text{mA}$	–	6.0	90.0	mV	
		$V_I = 12.5\text{V to } 19\text{V}$	–	4.0	45.0		
		$T_J = +25^{\circ}\text{C}$	$V_I = 11.5\text{V to } 24\text{V}$	–	6.0		90.0
		$V_I = 12.5\text{V to } 19\text{V}$	–	2.0	45.0		
Load Regulation (Note 26)	Regload	$T_J = +25^{\circ}\text{C}$, $I_O = 5\text{mA to } 1.0\text{mA}$	–	12.0	100	mV	
		$I_O = 5\text{mA to } 1\text{mA}$	–	12.0	100		
		$I_O = 250\text{mA to } 750\text{mA}$	–	5.0	50.0		
Quiescent Current	I_Q	$T_J = +25^{\circ}\text{C}$	–	5.0	6.0	mA	
Quiescent Current Change	ΔI_Q	$I_O = 5\text{mA to } 1\text{A}$	–	–	0.5	mA	
		$V_I = 12\text{V to } 25\text{V}$, $I_O = 500\text{mA}$	–	–	0.8		
		$V_I = 11.7\text{V to } 25\text{V}$, $T_J = +25^{\circ}\text{C}$	–	–	0.8		
Output Voltage Drift (Note 27)	$\Delta V_O/\Delta T$	$I_O = 5\text{mA}$	–	–1.0	–	mV/ $^{\circ}\text{C}$	
Output Noise Voltage	V_N	$f = 10\text{Hz to } 100\text{kHz}$, $T_A = +25^{\circ}\text{C}$	–	10.0	–	$\mu\text{V}/V_O$	
Ripple Rejection (Note 27)	RR	$f = 120\text{Hz}$, $I_O = 500\text{mA}$, $V_I = 12\text{V to } 22\text{V}$	–	62.0	–	dB	
Dropout Voltage	V_{DROP}	$I_O = 1\text{A}$, $T_J = +25^{\circ}\text{C}$	–	2.0	–	V	
Output Resistance (Note 27)	r_O	$f = 1\text{kHz}$	–	17.0	–	$\text{m}\Omega$	
Short Circuit Current	I_{SC}	$V_I = 35\text{V}$, $T_A = +25^{\circ}\text{C}$	–	250	–	mA	
Peak Current (Note 27)	I_{PK}	$T_J = +25^{\circ}\text{C}$	–	2.2	–	A	

Note 26: Load and line regulation are specified at constant junction temperature. Changes in V_O due to heating effects must be taken into account separately. Pulse testing with low duty is used.

Note 27: These parameters, although guaranteed, are not 100% tested in production.

Electrical Characteristics (LM7810A)

(Refer to the test circuits. $0^{\circ}\text{C} < T_J < 125^{\circ}\text{C}$, $I_O = 1\text{A}$, $V_I = 16\text{V}$, $C_I = 0.33\mu\text{F}$, $C_O = 0.1\mu\text{F}$, unless otherwise specified)

Parameter	Symbol	Conditions	Min	Typ	Max	Units	
Output Voltage	V_O	$T_J = +25^{\circ}\text{C}$	9.8	10.0	10.2	V	
		$I_O = 5\text{mA to } 1\text{A}$, $P_O \leq 15\text{W}$, $V_I = 12.8\text{V to } 25\text{V}$	9.6	10.0	10.4		
Line Regulation (Note 28)	Regline	$V_I = 12.8\text{V to } 26\text{V}$, $I_O = 500\text{mA}$	–	8.0	100	mV	
		$V_I = 13\text{V to } 20\text{V}$	–	4.0	50.0		
		$T_J = +25^{\circ}\text{C}$	$V_I = 12.5\text{V to } 25\text{V}$	–	8.0		100
		$V_I = 13\text{V to } 20\text{V}$	–	3.0	50.0		
Load Regulation (Note 28)	Regload	$T_J = +25^{\circ}\text{C}$, $I_O = 5\text{mA to } 1.5\text{mA}$	–	12.0	100	mV	
		$I_O = 5\text{mA to } 1\text{mA}$	–	12.0	100		
		$I_O = 250\text{mA to } 750\text{mA}$	–	5.0	50.0		
Quiescent Current	I_Q	$T_J = +25^{\circ}\text{C}$	–	5.0	6.0	mA	
Quiescent Current Change	ΔI_Q	$I_O = 5\text{mA to } 1\text{A}$	–	–	0.5	mA	
		$V_I = 12.8\text{V to } 25\text{V}$, $I_O = 500\text{mA}$	–	–	0.8		
		$V_I = 13\text{V to } 26\text{V}$, $T_J = +25^{\circ}\text{C}$	–	–	0.5		
Output Voltage Drift (Note 29)	$\Delta V_O/\Delta T$	$I_O = 5\text{mA}$	–	–1.0	–	mV/ $^{\circ}\text{C}$	
Output Noise Voltage	V_N	$f = 10\text{Hz to } 100\text{kHz}$, $T_A = +25^{\circ}\text{C}$	–	10.0	–	$\mu\text{V}/V_O$	
Ripple Rejection (Note 29)	RR	$f = 120\text{Hz}$, $I_O = 500\text{mA}$, $V_I = 14\text{V to } 24\text{V}$	–	62.0	–	dB	
Dropout Voltage	V_{DROP}	$I_O = 1\text{A}$, $T_J = +25^{\circ}\text{C}$	–	2.0	–	V	
Output Resistance (Note 29)	r_O	$f = 1\text{kHz}$	–	17.0	–	$\text{m}\Omega$	
Short Circuit Current	I_{SC}	$V_I = 35\text{V}$, $T_A = +25^{\circ}\text{C}$	–	250	–	mA	
Peak Current (Note 29)	I_{PK}	$T_J = +25^{\circ}\text{C}$	–	2.2	–	A	

Note 28: Load and line regulation are specified at constant junction temperature. Changes in V_O due to heating effects must be taken into account separately. Pulse testing with low duty is used.

Note 29: These parameters, although guaranteed, are not 100% tested in production.

Electrical Characteristics (LM7812A)

(Refer to the test circuits. $0^{\circ}\text{C} < T_J < 125^{\circ}\text{C}$, $I_O = 1\text{A}$, $V_I = 19\text{V}$, $C_I = 0.33\mu\text{F}$, $C_O = 0.1\mu\text{F}$, unless otherwise specified)

Parameter	Symbol	Conditions	Min	Typ	Max	Units	
Output Voltage	V_O	$T_J = +25^{\circ}\text{C}$	11.75	12.0	12.25	V	
		$I_O = 5\text{mA to } 1\text{A}$, $P_O \leq 15\text{W}$, $V_I = 14.8\text{V to } 27\text{V}$	11.5	12.0	12.5		
Line Regulation (Note 30)	Regline	$V_I = 14.8\text{V to } 30\text{V}$, $I_O = 500\text{mA}$	–	10.0	120	mV	
		$V_I = 16\text{V to } 22\text{V}$	–	4.0	120		
		$T_J = +25^{\circ}\text{C}$	$V_I = 14.5\text{V to } 27\text{V}$	–	10.0		120
			$V_I = 16\text{V to } 22\text{V}$	–	3.0		60.0
Load Regulation (Note 30)	Regload	$T_J = +25^{\circ}\text{C}$, $I_O = 5\text{mA to } 1.5\text{mA}$	–	12.0	100	mV	
		$I_O = 5\text{mA to } 1\text{mA}$	–	12.0	100		
		$I_O = 250\text{mA to } 750\text{mA}$	–	5.0	50.0		
Quiescent Current	I_Q	$T_J = +25^{\circ}\text{C}$	–	5.1	6.0	mA	
Quiescent Current Change	ΔI_Q	$I_O = 5\text{mA to } 1\text{A}$	–	–	0.5	mA	
		$V_I = 14\text{V to } 27\text{V}$, $I_O = 500\text{mA}$	–	–	0.8		
		$V_I = 15\text{V to } 30\text{V}$, $T_J = +25^{\circ}\text{C}$	–	–	0.8		
Output Voltage Drift (Note 31)	$\Delta V_O/\Delta T$	$I_O = 5\text{mA}$	–	–1.0	–	mV/ $^{\circ}\text{C}$	
Output Noise Voltage	V_N	$f = 10\text{Hz to } 100\text{kHz}$, $T_A = +25^{\circ}\text{C}$	–	10.0	–	$\mu\text{V}/V_O$	
Ripple Rejection (Note 31)	RR	$f = 120\text{Hz}$, $I_O = 500\text{mA}$, $V_I = 14\text{V to } 24\text{V}$	–	60.0	–	dB	
Dropout Voltage	V_{DROP}	$I_O = 1\text{A}$, $T_J = +25^{\circ}\text{C}$	–	2.0	–	V	
Output Resistance (Note 31)	r_O	$f = 1\text{kHz}$	–	18.0	–	$\text{m}\Omega$	
Short Circuit Current	I_{SC}	$V_I = 35\text{V}$, $T_A = +25^{\circ}\text{C}$	–	250	–	mA	
Peak Current (Note 31)	I_{PK}	$T_J = +25^{\circ}\text{C}$	–	2.2	–	A	

Note 30: Load and line regulation are specified at constant junction temperature. Changes in V_O due to heating effects must be taken into account separately. Pulse testing with low duty is used.

Note 31: These parameters, although guaranteed, are not 100% tested in production.

Electrical Characteristics (LM7815A)

(Refer to the test circuits. $0^{\circ}\text{C} < T_J < 125^{\circ}\text{C}$, $I_O = 1\text{A}$, $V_I = 23\text{V}$, $C_I = 0.33\mu\text{F}$, $C_O = 0.1\mu\text{F}$, unless otherwise specified)

Parameter	Symbol	Conditions	Min	Typ	Max	Units	
Output Voltage	V_O	$T_J = +25^{\circ}\text{C}$	14.75	15.0	15.3	V	
		$I_O = 5\text{mA to } 1\text{A}$, $P_O \leq 15\text{W}$, $V_I = 17.7\text{V to } 30\text{V}$	14.4	15.0	15.6		
Line Regulation (Note 32)	Regline	$V_I = 17.4\text{V to } 30\text{V}$, $I_O = 500\text{mA}$	–	10.0	150	mV	
		$V_I = 20\text{V to } 26\text{V}$	–	5.0	150		
		$T_J = +25^{\circ}\text{C}$	$V_I = 17.5\text{V to } 30\text{V}$	–	11.0		150
			$V_I = 20\text{V to } 26\text{V}$	–	3.0		75.0
Load Regulation (Note 32)	Regload	$T_J = +25^{\circ}\text{C}$, $I_O = 5\text{mA to } 1.5\text{mA}$	–	12.0	100	mV	
		$I_O = 5\text{mA to } 1\text{mA}$	–	12.0	100		
		$I_O = 250\text{mA to } 750\text{mA}$	–	5.0	50.0		
Quiescent Current	I_Q	$T_J = +25^{\circ}\text{C}$	–	5.2	6.0	mA	
Quiescent Current Change	ΔI_Q	$I_O = 5\text{mA to } 1\text{A}$	–	–	0.5	mA	
		$V_I = 17.5\text{V to } 30\text{V}$, $I_O = 500\text{mA}$	–	–	0.8		
		$V_I = 17.5\text{V to } 30\text{V}$, $T_J = +25^{\circ}\text{C}$	–	–	0.8		
Output Voltage Drift (Note 33)	$\Delta V_O/\Delta T$	$I_O = 5\text{mA}$	–	–1.0	–	mV/ $^{\circ}\text{C}$	
Output Noise Voltage	V_N	$f = 10\text{Hz to } 100\text{kHz}$, $T_A = +25^{\circ}\text{C}$	–	10.0	–	$\mu\text{V}/V_O$	
Ripple Rejection (Note 33)	RR	$f = 120\text{Hz}$, $I_O = 500\text{mA}$, $V_I = 18.5\text{V to } 28.5\text{V}$	–	58.0	–	dB	
Dropout Voltage	V_{DROP}	$I_O = 1\text{A}$, $T_J = +25^{\circ}\text{C}$	–	2.0	–	V	
Output Resistance (Note 33)	r_O	$f = 1\text{kHz}$	–	19.0	–	$\text{m}\Omega$	
Short Circuit Current	I_{SC}	$V_I = 35\text{V}$, $T_A = +25^{\circ}\text{C}$	–	250	–	mA	
Peak Current (Note 33)	I_{PK}	$T_J = +25^{\circ}\text{C}$	–	2.2	–	A	

Note 32: Load and line regulation are specified at constant junction temperature. Changes in V_O due to heating effects must be taken into account separately. Pulse testing with low duty is used.

Note 33: These parameters, although guaranteed, are not 100% tested in production.

Electrical Characteristics (LM7818A)

(Refer to the test circuits. $0^{\circ}\text{C} < T_J < 125^{\circ}\text{C}$, $I_O = 1\text{A}$, $V_I = 27\text{V}$, $C_I = 0.33\mu\text{F}$, $C_O = 0.1\mu\text{F}$, unless otherwise specified)

Parameter	Symbol	Conditions	Min	Typ	Max	Units	
Output Voltage	V_O	$T_J = +25^{\circ}\text{C}$	17.64	18.0	18.36	V	
		$I_O = 5\text{mA to } 1\text{A}$, $P_O \leq 15\text{W}$, $V_I = 21\text{V to } 33\text{V}$	17.3	18.0	18.7		
Line Regulation (Note 34)	Regline	$V_I = 21\text{V to } 33\text{V}$, $I_O = 500\text{mA}$	–	15.0	180	mV	
		$V_I = 21\text{V to } 33\text{V}$	–	5.0	180		
		$T_J = +25^{\circ}\text{C}$	$V_I = 20.6\text{V to } 33\text{V}$	–	15.0		180
			$V_I = 24\text{V to } 30\text{V}$	–	5.0		90.0
Load Regulation (Note 34)	Regload	$T_J = +25^{\circ}\text{C}$, $I_O = 5\text{mA to } 1.5\text{mA}$	–	15.0	100	mV	
		$I_O = 5\text{mA to } 1\text{mA}$	–	15.0	100		
		$I_O = 250\text{mA to } 750\text{mA}$	–	7.0	50.0		
Quiescent Current	I_Q	$T_J = +25^{\circ}\text{C}$	–	5.2	6.0	mA	
Quiescent Current Change	ΔI_Q	$I_O = 5\text{mA to } 1\text{A}$	–	–	0.5	mA	
		$V_I = 12\text{V to } 33\text{V}$, $I_O = 500\text{mA}$	–	–	0.8		
		$V_I = 12\text{V to } 33\text{V}$, $T_J = +25^{\circ}\text{C}$	–	–	0.8		
Output Voltage Drift (Note 35)	$\Delta V_O/\Delta T$	$I_O = 5\text{mA}$	–	–1.0	–	mV/ $^{\circ}\text{C}$	
Output Noise Voltage	V_N	$f = 10\text{Hz to } 100\text{kHz}$, $T_A = +25^{\circ}\text{C}$	–	10.0	–	$\mu\text{V}/V_O$	
Ripple Rejection (Note 35)	RR	$f = 120\text{Hz}$, $I_O = 500\text{mA}$, $V_I = 22\text{V to } 32\text{V}$	–	57.0	–	dB	
Dropout Voltage	V_{DROP}	$I_O = 1\text{A}$, $T_J = +25^{\circ}\text{C}$	–	2.0	–	V	
Output Resistance (Note 35)	r_O	$f = 1\text{kHz}$	–	19.0	–	$\text{m}\Omega$	
Short Circuit Current	I_{SC}	$V_I = 35\text{V}$, $T_A = +25^{\circ}\text{C}$	–	250	–	mA	
Peak Current (Note 35)	I_{PK}	$T_J = +25^{\circ}\text{C}$	–	2.2	–	A	

Note 34: Load and line regulation are specified at constant junction temperature. Changes in V_O due to heating effects must be taken into account separately. Pulse testing with low duty is used.

Note 35: These parameters, although guaranteed, are not 100% tested in production.

Electrical Characteristics (LM7824A)

(Refer to the test circuits. $0^{\circ}\text{C} < T_J < 125^{\circ}\text{C}$, $I_O = 1\text{A}$, $V_I = 33\text{V}$, $C_I = 0.33\mu\text{F}$, $C_O = 0.1\mu\text{F}$, unless otherwise specified)

Parameter	Symbol	Conditions	Min	Typ	Max	Units	
Output Voltage	V_O	$T_J = +25^{\circ}\text{C}$	23.5	24.0	24.5	V	
		$I_O = 5\text{mA to } 1\text{A}$, $P_O \leq 15\text{W}$, $V_I = 27.3\text{V to } 38\text{V}$	23.0	24.0	25.0		
Line Regulation (Note 36)	Regline	$V_I = 27\text{V to } 38\text{V}$, $I_O = 500\text{mA}$	–	18.0	240	mV	
		$V_I = 21\text{V to } 33\text{V}$	–	6.0	240		
		$T_J = +25^{\circ}\text{C}$	$V_I = 26.7\text{V to } 38\text{V}$	–	18.0		240
			$V_I = 30\text{V to } 36\text{V}$	–	6.0		120
Load Regulation (Note 36)	Regload	$T_J = +25^{\circ}\text{C}$, $I_O = 5\text{mA to } 1.5\text{mA}$	–	15.0	100	mV	
		$I_O = 5\text{mA to } 1\text{mA}$	–	15.0	100		
		$I_O = 250\text{mA to } 750\text{mA}$	–	7.0	50.0		
Quiescent Current	I_Q	$T_J = +25^{\circ}\text{C}$	–	5.2	6.0	mA	
Quiescent Current Change	ΔI_Q	$I_O = 5\text{mA to } 1\text{A}$	–	–	0.5	mA	
		$V_I = 27.3\text{V to } 38\text{V}$, $I_O = 500\text{mA}$	–	–	0.8		
		$V_I = 27.3\text{V to } 38\text{V}$, $T_J = +25^{\circ}\text{C}$	–	–	0.8		
Output Voltage Drift (Note 37)	$\Delta V_O / \Delta T$	$I_O = 5\text{mA}$	–	–1.5	–	mV/ $^{\circ}\text{C}$	
Output Noise Voltage	V_N	$f = 10\text{Hz to } 100\text{kHz}$, $T_A = +25^{\circ}\text{C}$	–	10.0	–	$\mu\text{V}/V_O$	
Ripple Rejection (Note 37)	RR	$f = 120\text{Hz}$, $I_O = 500\text{mA}$, $V_I = 28\text{V to } 38\text{V}$	–	54.0	–	dB	
Dropout Voltage	V_{DROP}	$I_O = 1\text{A}$, $T_J = +25^{\circ}\text{C}$	–	2.0	–	V	
Output Resistance (Note 37)	r_O	$f = 1\text{kHz}$	–	20.0	–	$\text{m}\Omega$	
Short Circuit Current	I_{SC}	$V_I = 35\text{V}$, $T_A = +25^{\circ}\text{C}$	–	250	–	mA	
Peak Current (Note 37)	I_{PK}	$T_J = +25^{\circ}\text{C}$	–	2.2	–	A	

Note 36: Load and line regulation are specified at constant junction temperature. Changes in V_O due to heating effects must be taken into account separately. Pulse testing with low duty is used.

Note 37: These parameters, although guaranteed, are not 100% tested in production.

Typical Performance Characteristics

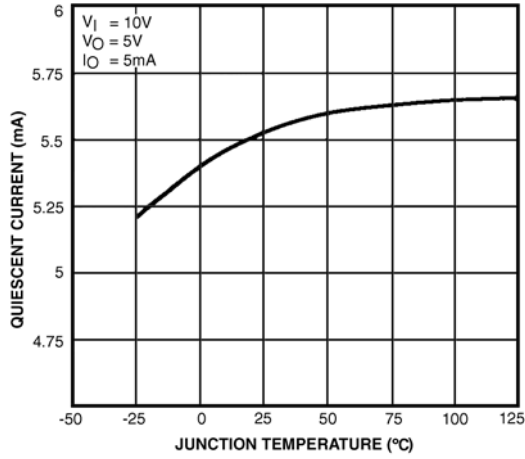

FIGURE 1. Quiescent Current

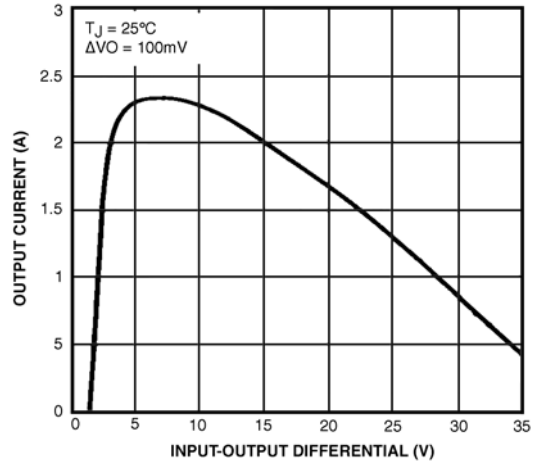

FIGURE 2. Peak Output Current

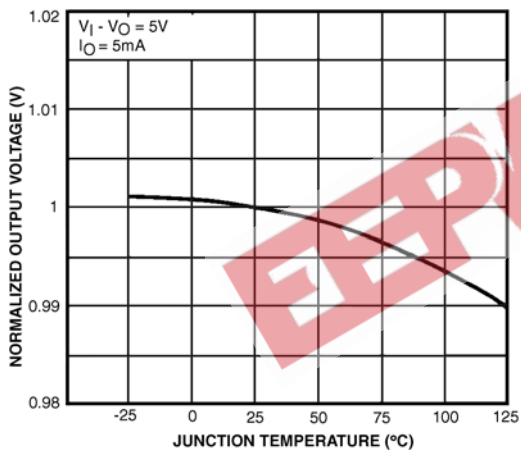

FIGURE 3. Output Voltage

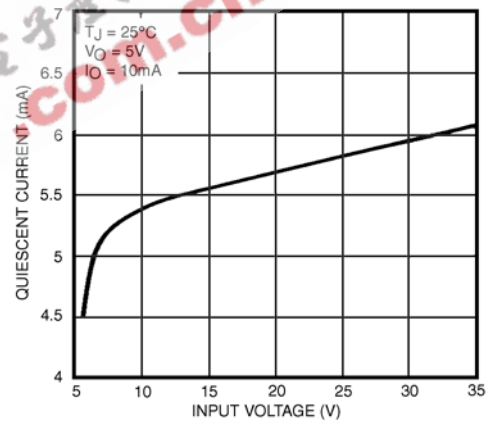
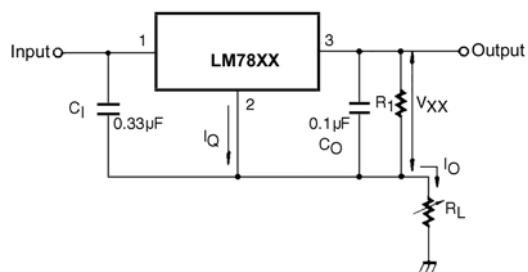

FIGURE 4. Quiescent Current

Typical Applications (continued)



$$I_O = \frac{V_{XX}}{R_1} + I_Q$$

FIGURE 9.

Note: To specify an output voltage, substitute voltage value for "XX". A common ground is required between the Input and the Output voltage. The input voltage must remain typically 2.0V above the output voltage even during the low point on the input ripple voltage.

Note: C₁ is required if regulator is located an appreciable distance from the power supply filter.

Note: C₀ improves stability and transient response.

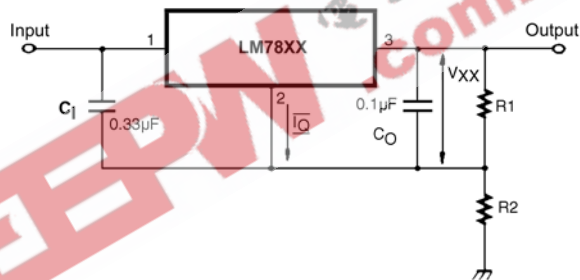

$$I_{R1} \geq 5 I_Q$$

$$V_O = V_{XX} (1 R_2 / R_1) + I_Q R_2$$

FIGURE 10. Circuit for Increasing Output Voltage

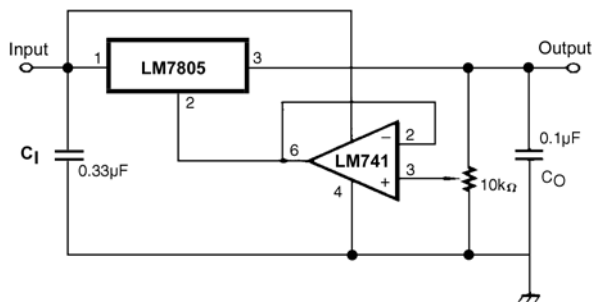

$$I_{R1} \geq 5 I_Q$$

$$V_O = V_{XX} (1 R_2 / R_1) + I_Q R_2$$

FIGURE 11. Adjustable Output Regulator (7V to 30V)

Typical Applications (continued)

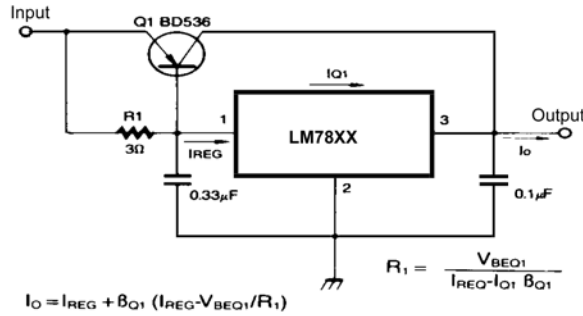

FIGURE 12. High Current Voltage Regulator

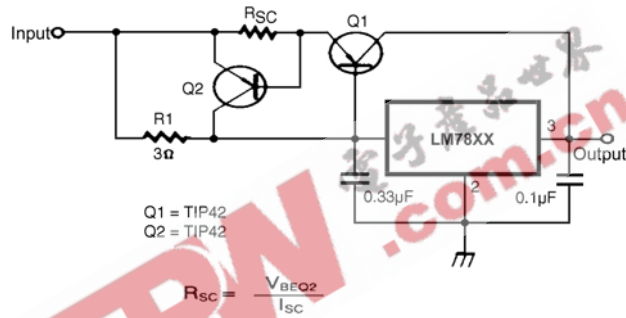

FIGURE 13. High Output Current with Short Circuit Protection

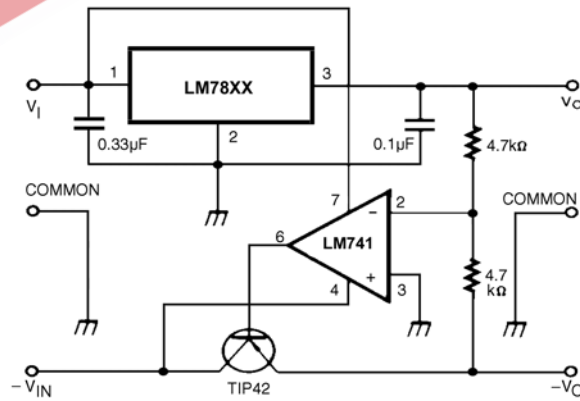

FIGURE 14. Tracking Voltage Regulator

Typical Applications (continued)

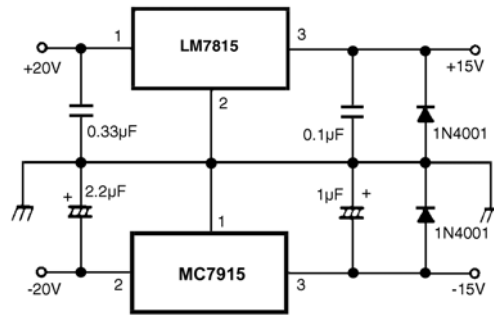

FIGURE 15. Split Power Supply ($\pm 15V - 1A$)

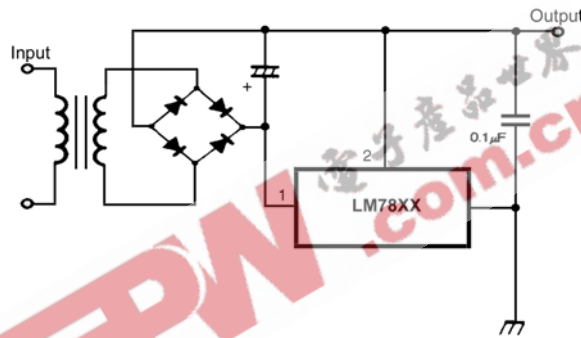

FIGURE 16. Negative Output Voltage Circuit

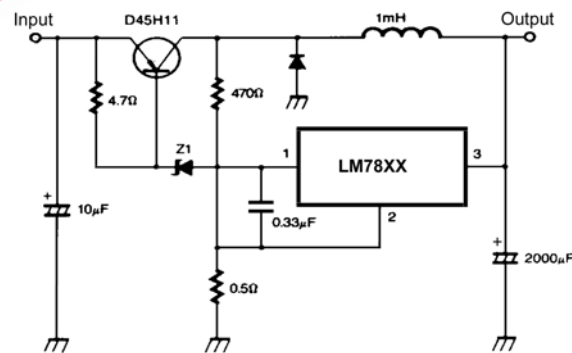
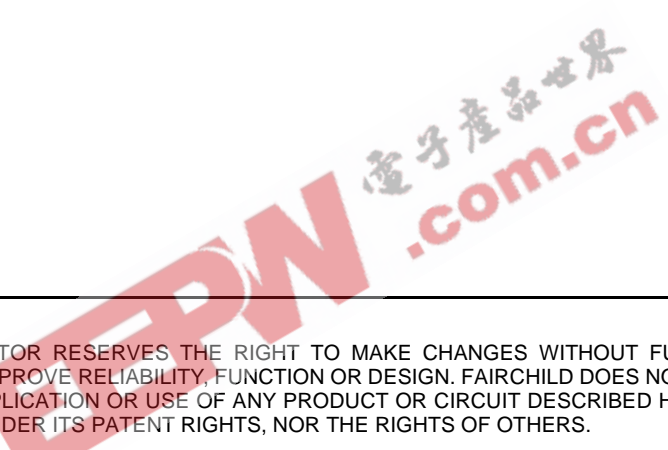

FIGURE 17. Switching Regulator

LM7805 • LM7806 • LM7808 • LM7809 • LM7810 • LM7812 • LM7815 • LM7818 • LM7824 • LM7805A • LM7806A • LM7808A
 • LM7809A • LM7810A • LM7812A • LM7815A • LM7818A • LM7824A



DISCLAIMER

FAIRCHILD SEMICONDUCTOR RESERVES THE RIGHT TO MAKE CHANGES WITHOUT FURTHER NOTICE TO ANY PRODUCTS HEREIN TO IMPROVE RELIABILITY, FUNCTION OR DESIGN. FAIRCHILD DOES NOT ASSUME ANY LIABILITY ARISING OUT OF THE APPLICATION OR USE OF ANY PRODUCT OR CIRCUIT DESCRIBED HEREIN; NEITHER DOES IT CONVEY ANY LICENSE UNDER ITS PATENT RIGHTS, NOR THE RIGHTS OF OTHERS.

LIFE SUPPORT POLICY

FAIRCHILD'S PRODUCTS ARE NOT AUTHORIZED FOR USE AS CRITICAL COMPONENTS IN LIFE SUPPORT DEVICES OR SYSTEMS WITHOUT THE EXPRESS WRITTEN APPROVAL OF FAIRCHILD SEMICONDUCTOR CORPORATION

As used herein:

1. Life support devices or systems are devices or systems which, (a) are intended for surgical implant into the body, or (b) support or sustain life, or (c) whose failure to perform when properly used in accordance with instructions for use

provided in the labeling, can be reasonably expected to result in significant injury to the user.

2. A critical component is any component of a life support device or system whose failure to perform can be reasonably expected to cause the failure of the life support device or system, or to affect its safety or effectiveness.

PRODUCT STATUS DEFINITIONS

Definition of terms

Datasheet Identification	Product Status	Definition
Advance Information	Formative or In Design	This datasheet contains the design specifications for product development. Specifications may change in any manner without notice.
Preliminary	First Production	This datasheet contains preliminary data, and supplementary data will be published at a later date. Fairchild Semiconductor reserves the right to make changes at any time without notice in order to improve design.
No Identification Needed	Full Production	This datasheet contains final specifications. Fairchild Semiconductor reserves the right to make changes at any time without notice in order to improve design.
Obsolete	Not In Production	This datasheet contains specifications on a product that has been discontinued by Fairchild Semiconductor. The datasheet is printed for reference information only.