

8 BIT BINARY COUNTER REGISTER (3 STATE)

- HIGH SPEED
 $f_{MAX} = 62 \text{ MHz (TYP.) AT } V_{CC} = 5 \text{ V}$
- LOW POWER DISSIPATION
 $I_{CC} = 4 \mu\text{A (MAX.) AT } T_A = 25 \text{ }^\circ\text{C}$
- HIGH NOISE IMMUNITY
 $V_{NIH} = V_{NIL} = 28 \% V_{CC} \text{ (MIN.)}$
- OUTPUT DRIVE CAPABILITY
 10 LSTTL LOADS (for RCO)
 15 LSTTL LOADS (for QA ~ QH)
- SYMMETRICAL OUTPUT IMPEDANCE
 $|I_{OH}| = I_{OL} = 6 \text{ mA (MIN.) FOR QA ~ QH OUTPUT}$
 $|I_{OH}| = I_{OL} = 4 \text{ mA (MIN.) FOR RCO OUTPUT}$
- BALANCED PROPAGATION DELAYS
 $t_{PLH} = t_{PHL}$
- WIDE OPERATING VOLTAGE RANGE
 $V_{CC} \text{ (OPR)} = 2 \text{ V TO } 6 \text{ V}$
- PIN AND FUNCTION COMPATIBLE WITH 54/74LS590

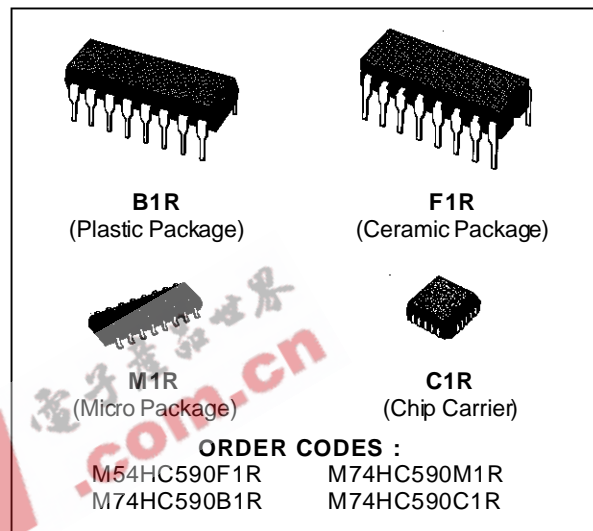

DESCRIPTION

The M54/74HC590 is a high speed CMOS 8-BIT BINARY COUNTER REGISTER (3-STATE) fabricated in silicon gate C²MOS technology. It has the same high speed performance of LSTTL combined with true CMOS low power consumption.

These devices each contain an 8-bit binary counter that feeds an 8-bit storage register. The storage register has parallel outputs. Separate clocks are provided for both the binary counter and storage register. The binary counter features a direct clear input $\overline{\text{CCLR}}$ and a count enable input $\overline{\text{CCKEN}}$. For cascading, a ripple carry output $\overline{\text{RCO}}$ is provided. Expansion is easily accomplished by tying $\overline{\text{RCO}}$ of the first stage to $\overline{\text{CCKEN}}$ of the second stage, etc. Both the counter and register clocks are positive-edge triggered. If the user wishes to connect both clocks together, the counter state will always be one count ahead of the register. Internal circuitry prevents clocking from the clock enable.

All inputs are equipped with protection circuits against static discharge and transient excess voltage.

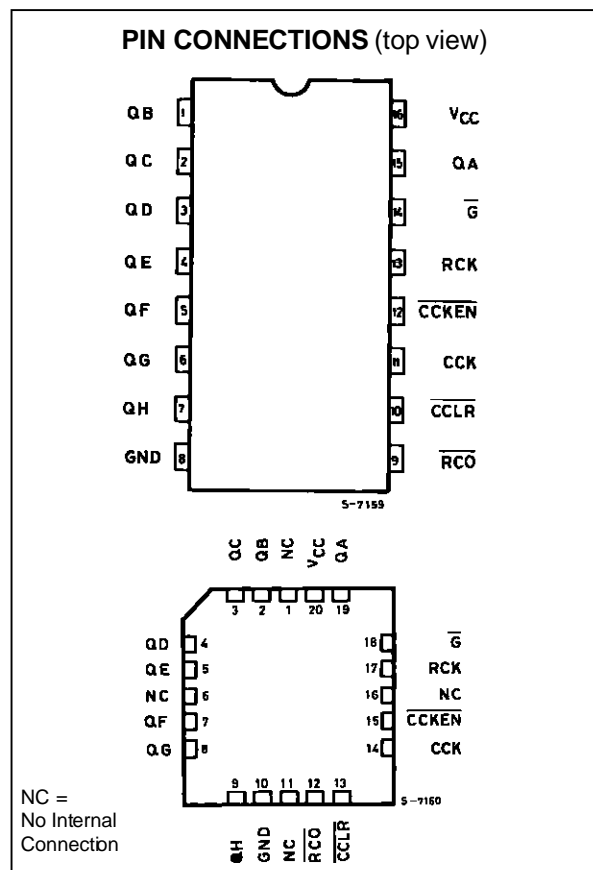

M54/M74HC590

INPUT AND OUTPUT EQUIVALENT CIRCUIT

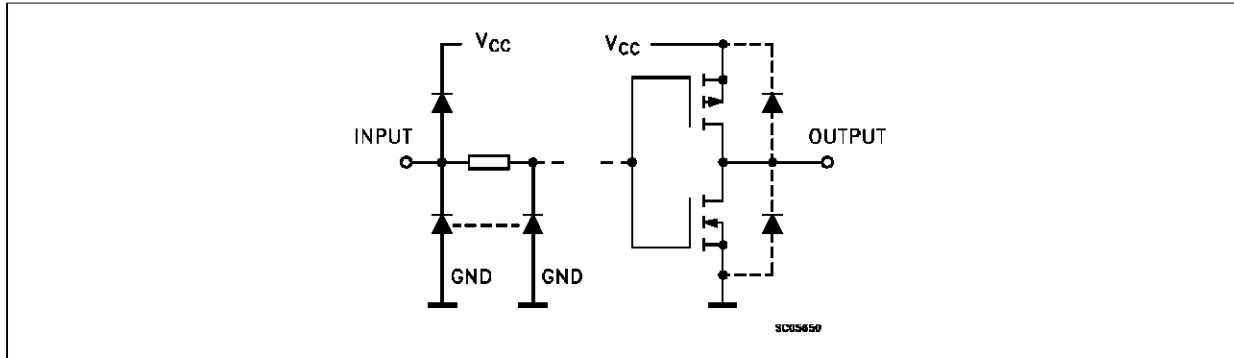

TRUTH TABLE

INPUTS					OUTPUT
\overline{G}	RCK	\overline{CCLR}	\overline{CCKEN}	CCK	
H	X	X	X	X	Q OUTPUTS DISABLE
L	X	X	X	X	Q OUTPUTS ENABLE
X		X	X	X	COUNTER DATA IS STORED INTO REGISTER
X		X	X	X	REGISTER STATE IS NOT CHANGED
X	X	L	X	X	COUNTER CLEAR
X	X	H	L		ADVANCE ONE COUNT
X	X	H	L		NO COUNT
X	X	H	H	X	NO COUNT

X: DON'T CARE

$RCO = QA' \cdot QB' \cdot QC' \cdot QD' \cdot QE' \cdot QF' \cdot QG' \cdot QH'$ (QA' to QH': INTERNAL OUTPUTS OF THE COUNTER)

LOGIC DIAGRAM

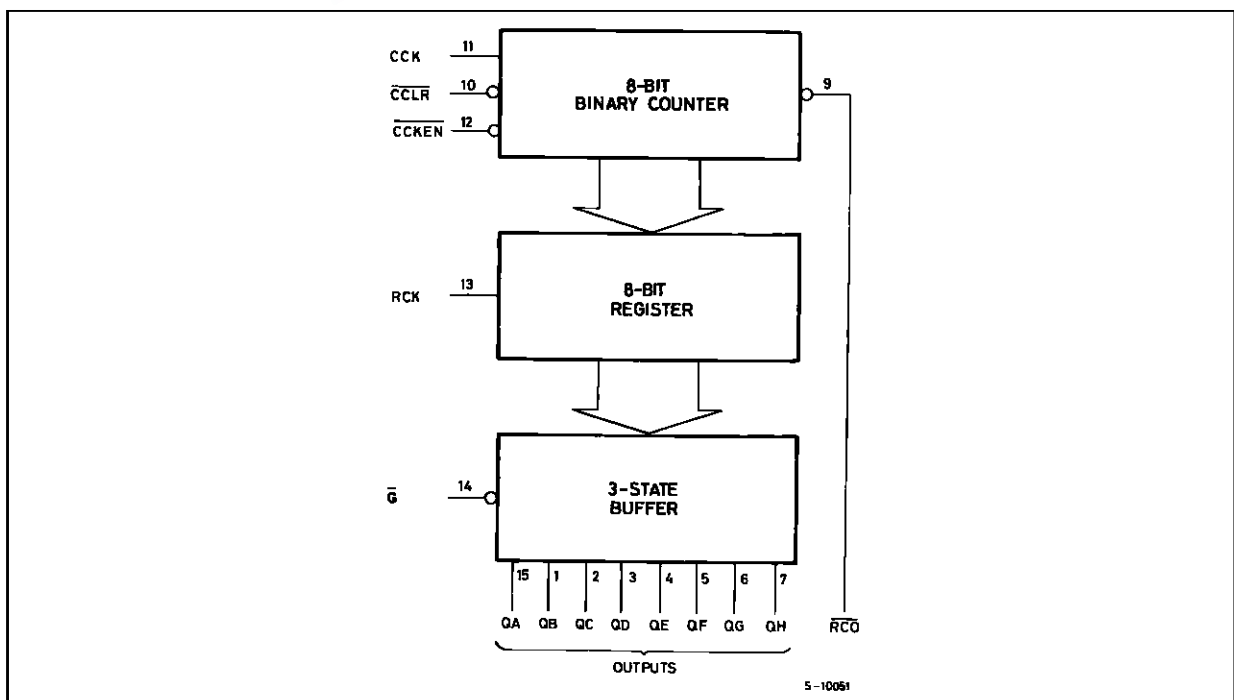

LOGIC DIAGRAM

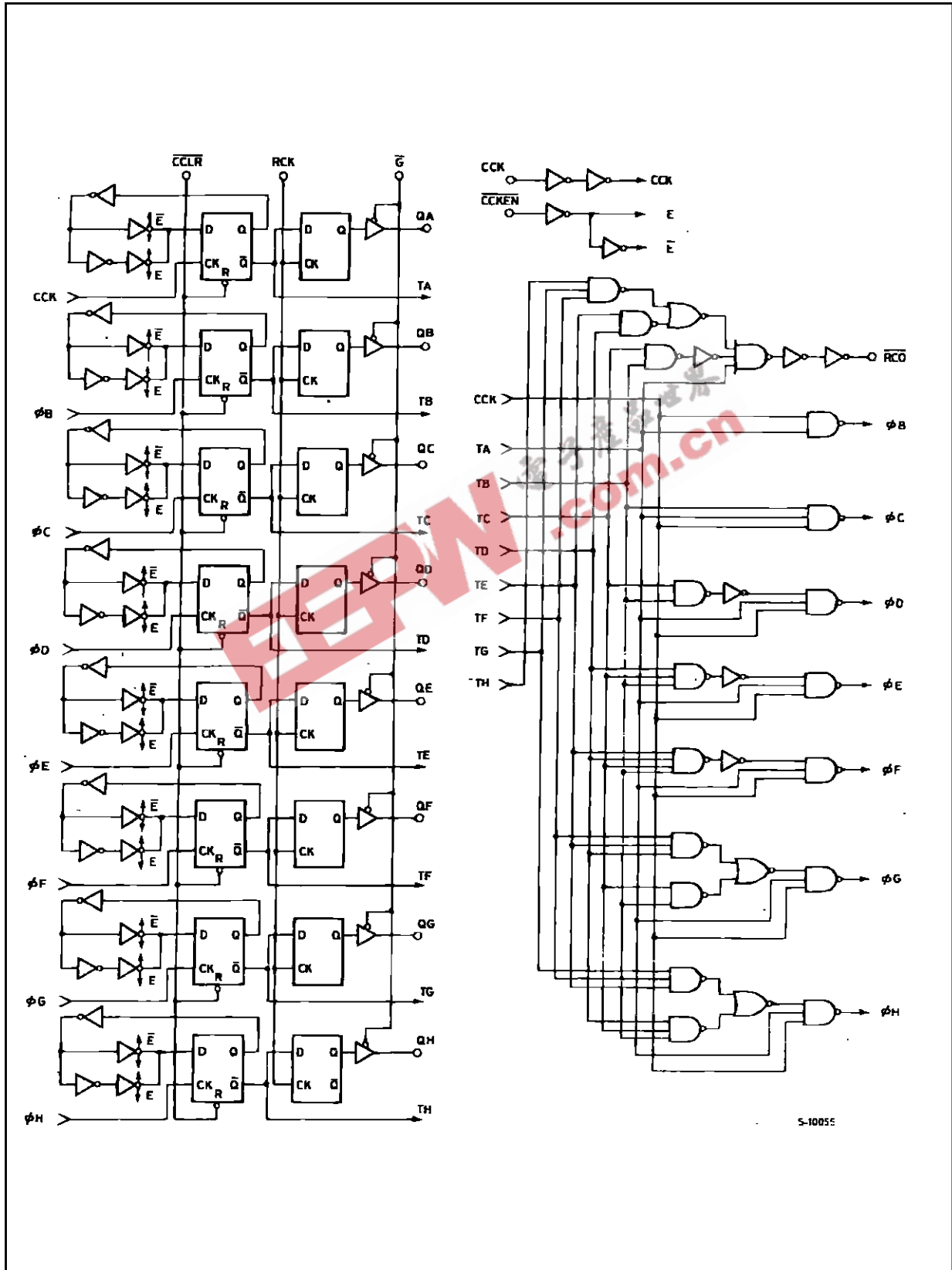

TIMING CHART

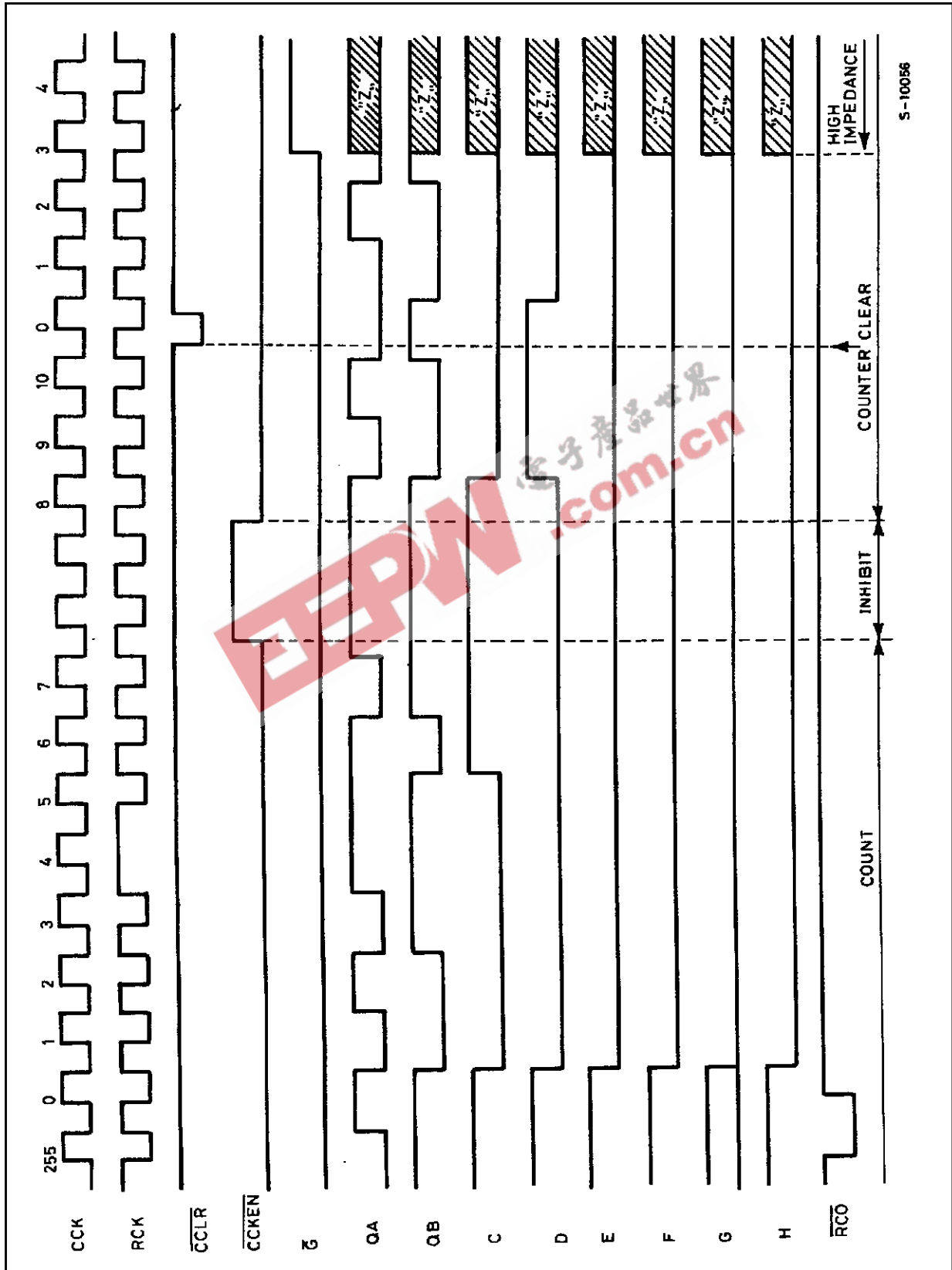

S-10056

PIN DESCRIPTION

PIN No	SYMBOL	NAME AND FUNCTION
1, 2, 3, 4, 5, 6, 7, 15	QA to QH	Outputs
11	CCK	Counter Clock Input
12	$\overline{\text{CCKEN}}$	Counter Clock Enable Input
13	RCK	Register Clock Input
9	$\overline{\text{RCO}}$	Ripple Carry Output
14	G	Output Enable Input
10	$\overline{\text{CCLR}}$	Counter Clear Input
8	GND	Ground (0V)
16	V _{CC}	Positive Supply Voltage

IEC LOGIC SYMBOL

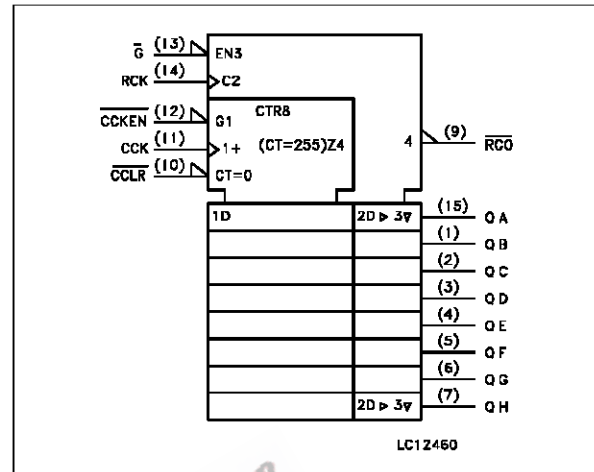

ABSOLUTE MAXIMUM RATINGS

Symbol	Parameter	Value	Unit
V _{CC}	Supply Voltage	-0.5 to +7	V
V _I	DC Input Voltage	-0.5 to V _{CC} + 0.5	V
V _O	DC Output Voltage	-0.5 to V _{CC} + 0.5	V
I _{IK}	DC Input Diode Current	± 20	mA
I _{OK}	DC Output Diode Current	± 20	mA
I _O	DC Output Source Sink Current Per Output Pin (RCO) (Q _A - Q _H)	± 25 ± 35	mA
I _{CC} or I _{IGND}	DC V _{CC} or Ground Current	± 70	mA
P _D	Power Dissipation	500 (*)	mW
T _{stg}	Storage Temperature	-65 to +150	°C
T _L	Lead Temperature (10 sec)	300	°C

Absolute Maximum Ratings are those values beyond which damage to the device may occur. Functional operation under these condition is not implied.

(*) 500 mW: ≅ 65 °C derate to 300 mW by 10mW/°C: 65 °C to 85 °C

RECOMMENDED OPERATING CONDITIONS

Symbol	Parameter	Value	Unit	
V _{CC}	Supply Voltage	2 to 6	V	
V _I	Input Voltage	0 to V _{CC}	V	
V _O	Output Voltage	0 to V _{CC}	V	
T _{op}	Operating Temperature: M54HC Series M74HC Series	-55 to +125 -40 to +85	°C °C	
t _r , t _f	Input Rise and Fall Time	V _{CC} = 2 V V _{CC} = 4.5 V V _{CC} = 6 V	0 to 1000 0 to 500 0 to 400	ns

M54/M74HC590

DC SPECIFICATIONS

Symbol	Parameter	Test Conditions		Value						Unit		
		V _{CC} (V)		T _A = 25 °C 54HC and 74HC			-40 to 85 °C 74HC		-55 to 125 °C 54HC			
				Min.	Typ.	Max.	Min.	Max.	Min.		Max.	
V _{IH}	High Level Input Voltage	2.0		1.5			1.5		1.5		V	
		4.5		3.15			3.15		3.15			
		6.0		4.2			4.2		4.2			
V _{IL}	Low Level Input Voltage	2.0				0.5		0.5		0.5	V	
		4.5				1.35		1.35		1.35		
		6.0				1.8		1.8		1.8		
V _{OH}	High Level Output Voltage (for RCO output)	2.0	V _I = V _{IH} or V _{IL}	I _O = -20 μA	1.9	2.0		1.9		1.9	V	
		4.5			4.4	4.5		4.4		4.4		
		6.0			5.9	6.0		5.9		5.9		
		4.5		I _O = -4.0 mA	4.18	4.31		4.13		4.10		
		6.0		I _O = -5.2 mA	5.68	5.8		5.63		5.60		
V _{OH}	High Level Output Voltage (for QA to QH outputs)	2.0	V _I = V _{IH} or V _{IL}	I _O = -20 μA	1.9	2.0		1.9		1.9	V	
		4.5			4.4	4.5		4.4		4.4		
		6.0			5.9	6.0		5.9		5.9		
		4.5		I _O = -6.0 mA	4.18	4.31		4.13		4.10		
		6.0		I _O = -7.8 mA	5.68	5.8		5.63		5.60		
V _{OL}	Low Level Output Voltage (for RCO output)	2.0	V _I = V _{IH} or V _{IL}	I _O = 20 μA		0.0	0.1		0.1		0.1	V
		4.5				0.0	0.1		0.1		0.1	
		6.0				0.0	0.1		0.1		0.1	
		4.5		I _O = 4.0 mA		0.17	0.26		0.33		0.40	
		6.0		I _O = 5.2 mA		0.18	0.26		0.33		0.40	
V _{OL}	Low Level Output Voltage (for QA to QH outputs)	2.0	V _I = V _{IH} or V _{IL}	I _O = 20 μA		0.0	0.1		0.1		0.1	V
		4.5				0.0	0.1		0.1		0.1	
		6.0				0.0	0.1		0.1		0.1	
		4.5		I _O = 6.0 mA		0.17	0.26		0.33		0.40	
		6.0		I _O = 7.8 mA		0.18	0.26		0.33		0.40	
I _I	Input Leakage Current	6.0	V _I = V _{CC} or GND			±0.1		±1		±1	μA	
I _{OZ}	3 State Output Off State Current	6.0	V _O = V _{CC} or GND			±0.5		±5		±10	μA	
I _{CC}	Quiescent Supply Current	6.0	V _I = V _{CC} or GND			4		40		80	μA	

AC ELECTRICAL CHARACTERISTICS ($C_L = 50$ pF, Input $t_r = t_f = 6$ ns)

Symbol	Parameter	Test Conditions			Value						Unit	
		V _{CC} (V)	C _L (pF)		T _A = 25 °C 54HC and 74HC			-40 to 85 °C 74HC		-55 to 125 °C 54HC		
					Min.	Typ.	Max.	Min.	Max.	Min.		Max.
t _{TLH} t _{THL}	Output Transition Time (Qn)	2.0	50			25	60		75		90	ns
		4.5			7	12		15		18		
		6.0			6	10		13		15		
t _{TLH} t _{THL}	Output Transition Time (RCO)	2.0	50			30	75		95		115	ns
		4.5			8	15		19		23		
		6.0			7	13		16		20		
t _{PLH} t _{PHL}	Propagation Delay Time (CCK - RCO)	2.0	50			56	165		205		250	ns
		4.5			19	33		41		50		
		6.0			16	28		35		43		
t _{PLH}	Propagation Delay Time (CCLR - RCO)	2.0	50			53	175		220		265	ns
		4.5			21	35		44		53		
		6.0			18	30		37		45		
t _{PLH} t _{PHL}	Propagation Delay Time (RCK - Q)	2.0	50			48	145		180		220	ns
		4.5			17	29		36		44		
		6.0			14	25		31		37		
		2.0	150			60	185		230		280	ns
		4.5			21	37		46		56		
		6.0			18	31		39		48		
t _{PZL} t _{PZH}	Output Enable Time	2.0	50	R _L = 1 KΩ		39	105		130		160	ns
		4.5				13	21		26		32	
		6.0				11	18		22		27	
		2.0	150	R _L = 1 KΩ		51	135		170		205	ns
		4.5				17	27		34		41	
		0				14	23		29		35	
t _{PLZ} t _{PHZ}	Output Disable Time	2.0	50	R _L = 1 KΩ		28	105		130		160	ns
		4.5				14	21		26		32	
		6.0				12	18		22		27	
f _{MAX}	Maximum Clock Frequency	2.0	50		6.6	13		5.2		4.4	ns	
		4.5			33	52		26		22		
		6.0			39	61		31		26		
t _{w(L)} t _{w(H)}	Minimum Pulse Width (CCK, RCK)	2.0	50			36	100		125		145	ns
		4.5			9	20		25		29		
		6.0			8	17		21		25		
t _{w(L)}	Minimum Pulse Width (CCLR)	2.0	50			32	75		95		110	ns
		4.5			8	15		19		22		
		6.0			7	13		16		19		
t _s	Minimum Set-up Time (CCKEN - CCK)	2.0	50			44	100		125		150	ns
		4.5			11	20		25		30		
		6.0			9	17		21		26		

M54/M74HC590

AC ELECTRICAL CHARACTERISTICS ($C_L = 50 \text{ pF}$, Input $t_r = t_f = 6 \text{ ns}$)

Symbol	Parameter	Test Conditions			Value						Unit	
		V_{CC} (V)	C_L (pF)		$T_A = 25 \text{ }^\circ\text{C}$ 54HC and 74HC			$-40 \text{ to } 85 \text{ }^\circ\text{C}$ 74HC		$-55 \text{ to } 125 \text{ }^\circ\text{C}$ 54HC		
					Min.	Typ.	Max.	Min.	Max.	Min.		Max.
$t_{s(H)}$	Minimum Set-up Time (CCK - RCK)	2.0	50		76	175		220		255	ns	
		4.5		19	35		44		51			
		6.0		16	30		37		43			
t_h	Minimum Hold Time	2.0	50			0		0		0	ns	
		4.5			0		0		0			
		6.0			0		0		0			
t_{REM}	Minimum Hold Time (CCLR)	2.0	50		28	75		95		110	ns	
		4.5			7	15		19		22		
		6.0			6	13		16		19		
C_{IN}	Input Capacitance				5	10		10		10	pF	
C_{PD}^*	Power Dissipation Capacitance				40						pF	

(*) C_{PD} is defined as the value of the IC's internal equivalent capacitance which is calculated from the operating current consumption without load. (Refer to Test Circuit). Average operating current can be obtained by the following equation. $I_{CC(opr)} = C_{PD} \cdot V_{CC} \cdot f_{IN} + I_{CC}$

TEST WAVEFORM I_{CC} (Opr.)

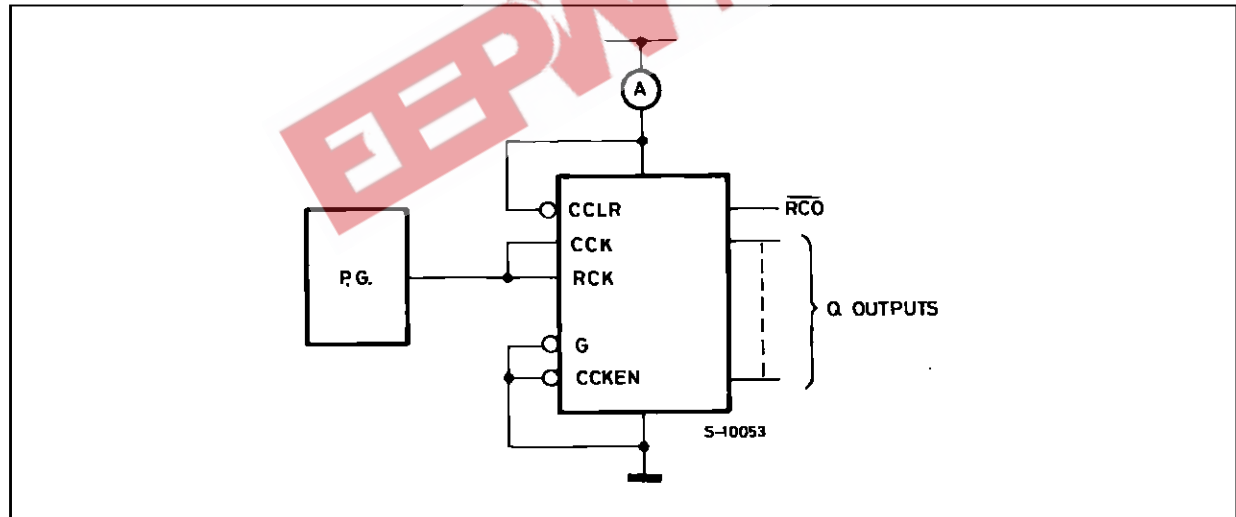

SWITCHING CHARACTERISTICS TEST WAVEFORM

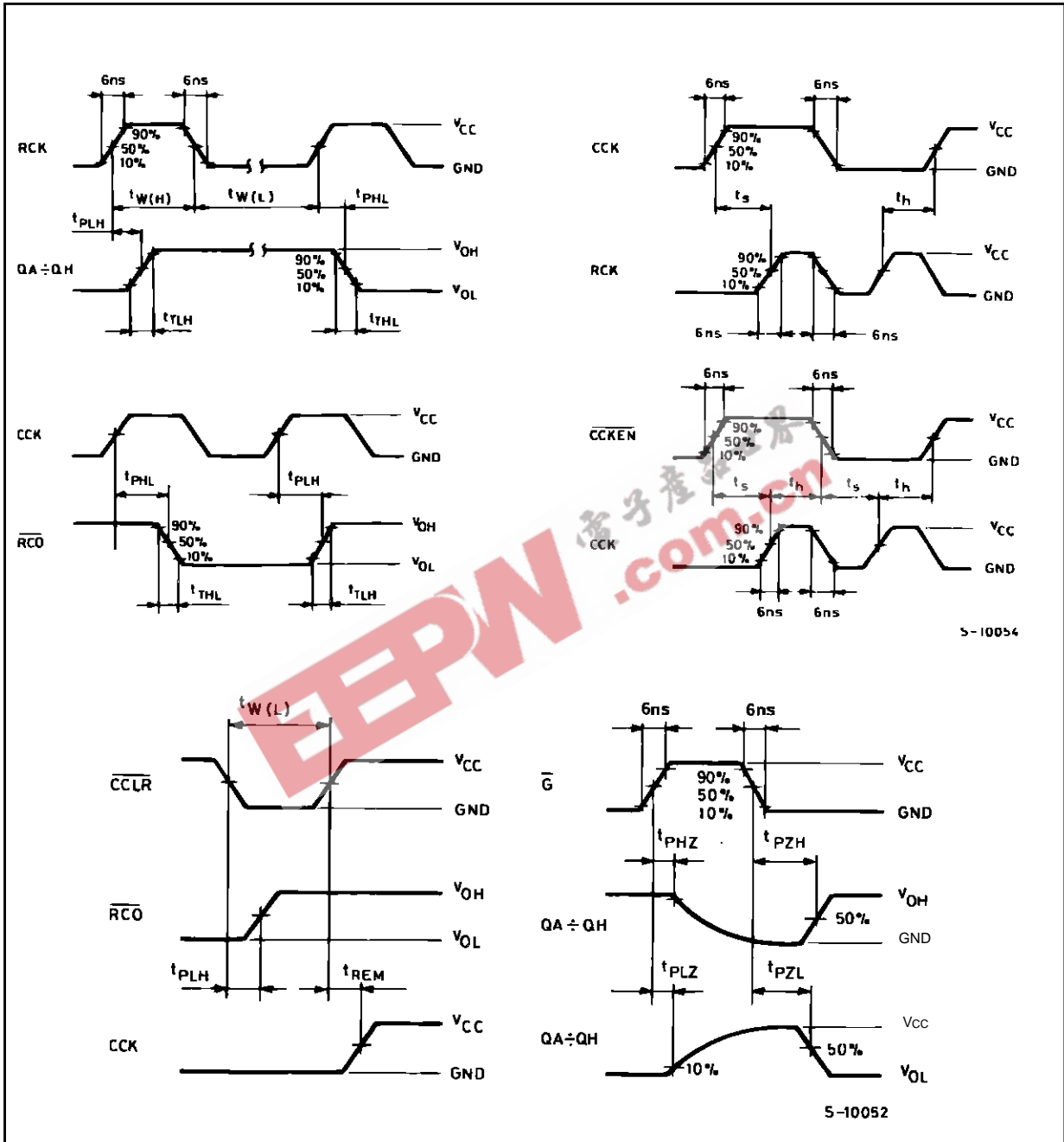

M54/M74HC590

Plastic DIP16 (0.25) MECHANICAL DATA

DIM.	mm			inch		
	MIN.	TYP.	MAX.	MIN.	TYP.	MAX.
a1	0.51			0.020		
B	0.77		1.65	0.030		0.065
b		0.5			0.020	
b1		0.25			0.010	
D			20			0.787
E		8.5			0.335	
e		2.54			0.100	
e3		17.78			0.700	
F			7.1			0.280
I			5.1			0.201
L		3.3			0.130	
Z			1.27			0.050

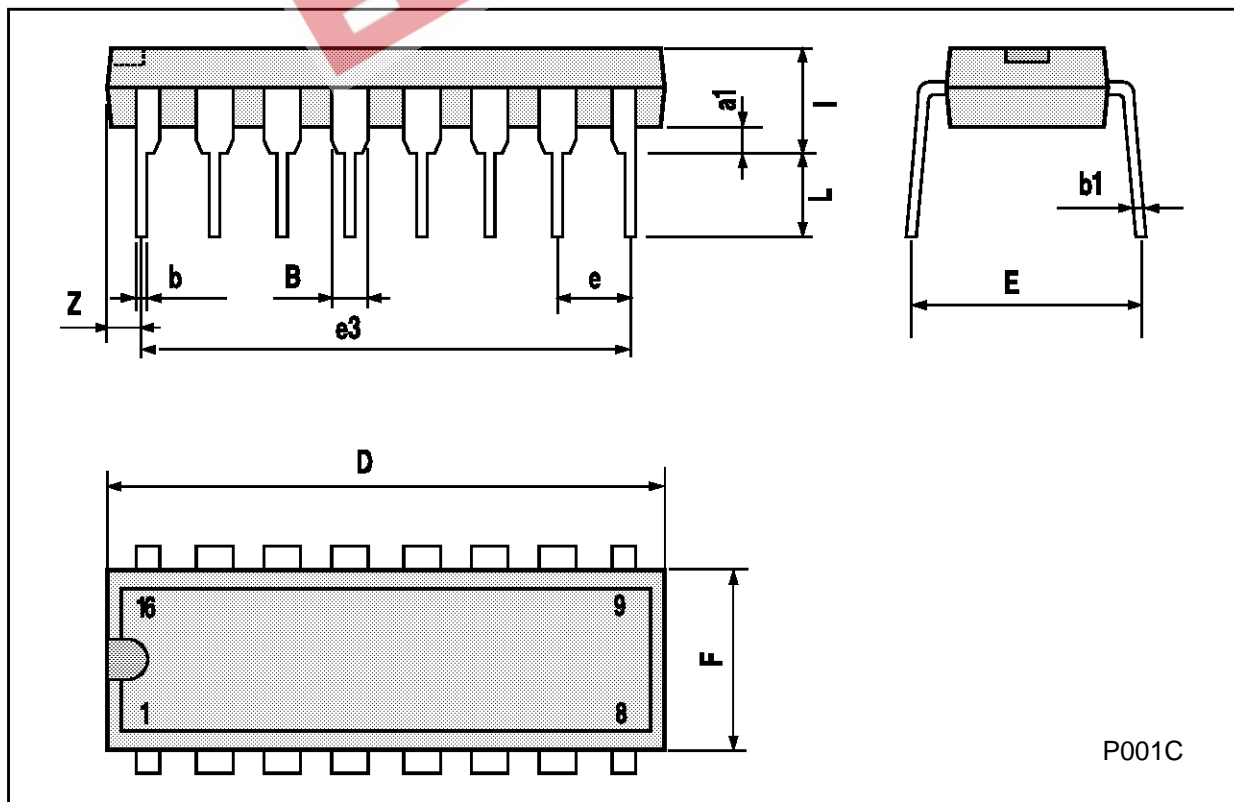

P001C

Ceramic DIP16/1 MECHANICAL DATA

DIM.	mm			inch		
	MIN.	TYP.	MAX.	MIN.	TYP.	MAX.
A			20			0.787
B			7			0.276
D		3.3			0.130	
E	0.38			0.015		
e3		17.78			0.700	
F	2.29		2.79	0.090		0.110
G	0.4		0.55	0.016		0.022
H	1.17		1.52	0.046		0.060
L	0.22		0.31	0.009		0.012
M	0.51		1.27	0.020		0.050
N			10.3			0.406
P	7.8		8.05	0.307		0.317
Q			5.08			0.200

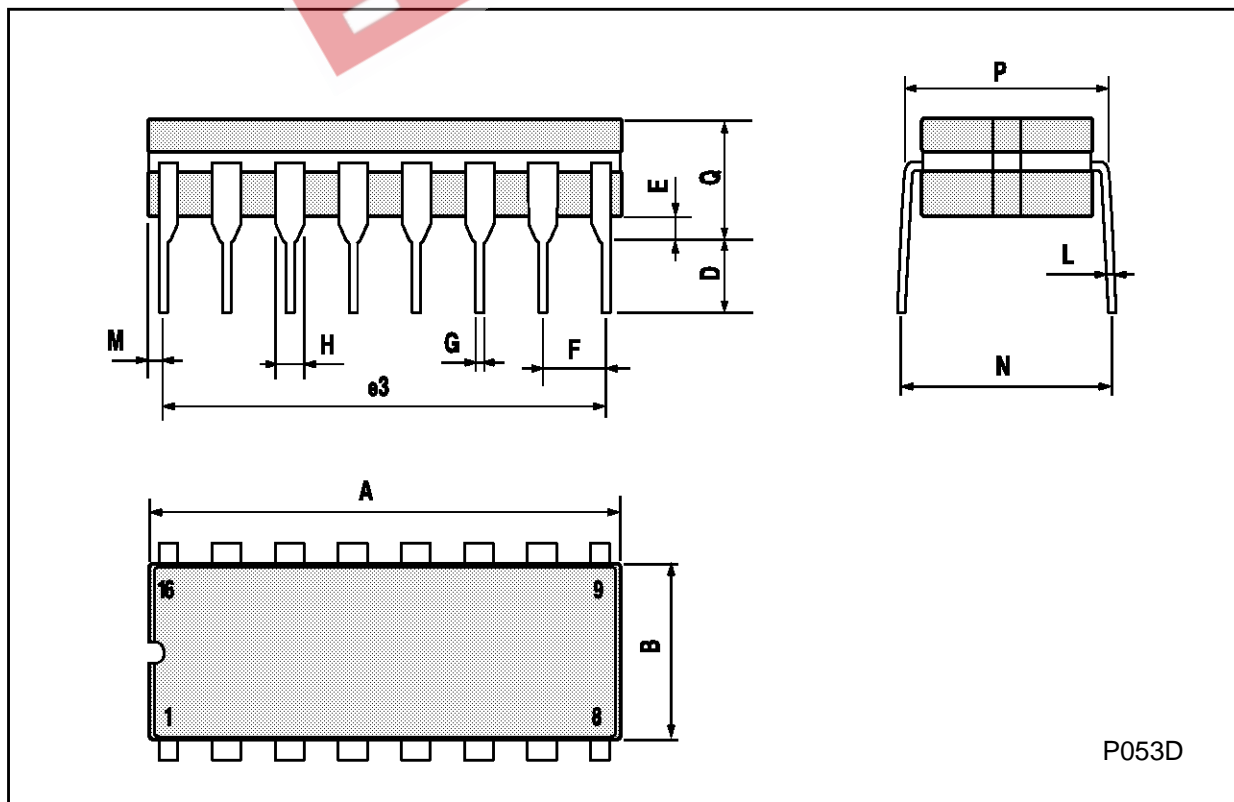

SO16 (Narrow) MECHANICAL DATA

DIM.	mm			inch		
	MIN.	TYP.	MAX.	MIN.	TYP.	MAX.
A			1.75			0.068
a1	0.1		0.2	0.004		0.007
a2			1.65			0.064
b	0.35		0.46	0.013		0.018
b1	0.19		0.25	0.007		0.010
C		0.5			0.019	
c1	45° (typ.)					
D	9.8		10	0.385		0.393
E	5.8		6.2	0.228		0.244
e		1.27			0.050	
e3		8.89			0.350	
F	3.8		4.0	0.149		0.157
G	4.6		5.3	0.181		0.208
L	0.5		1.27	0.019		0.050
M			0.62			0.024
S	8° (max.)					

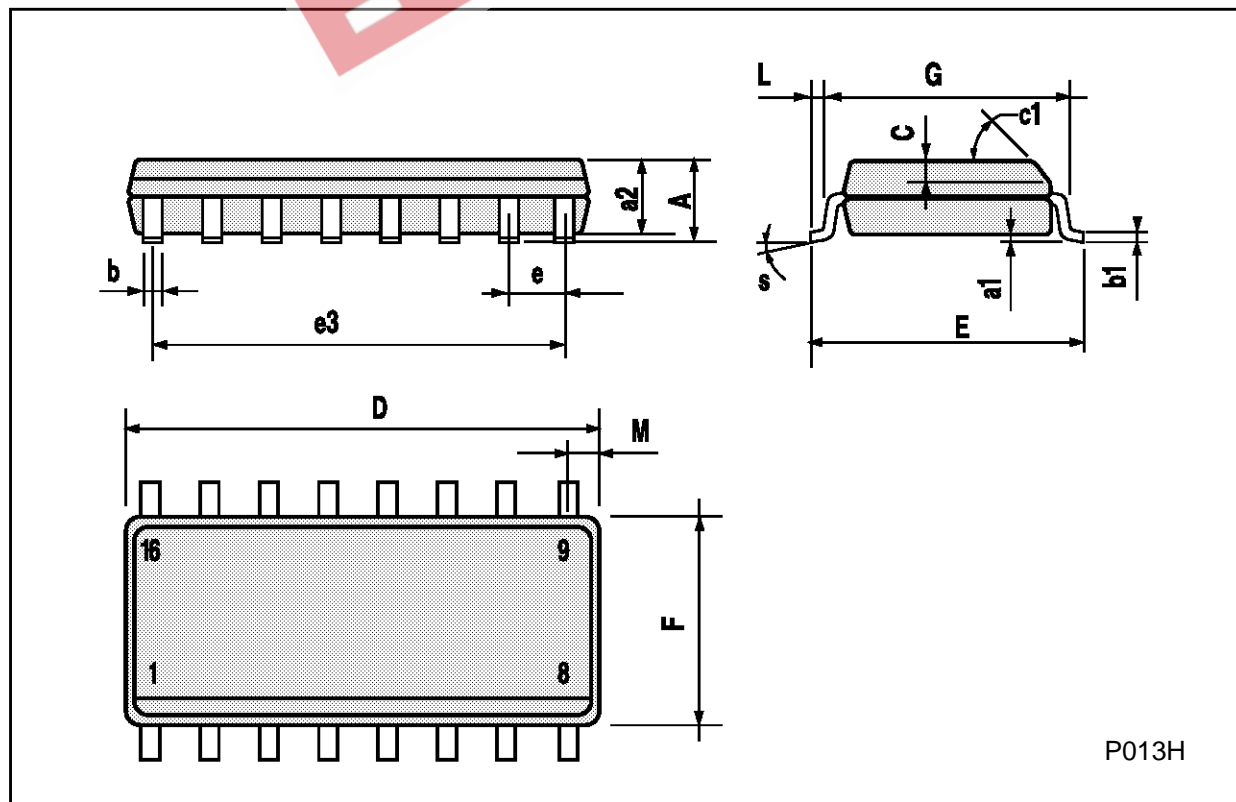

PLCC20 MECHANICAL DATA

DIM.	mm			inch		
	MIN.	TYP.	MAX.	MIN.	TYP.	MAX.
A	9.78		10.03	0.385		0.395
B	8.89		9.04	0.350		0.356
D	4.2		4.57	0.165		0.180
d1		2.54			0.100	
d2		0.56			0.022	
E	7.37		8.38	0.290		0.330
e		1.27			0.050	
e3		5.08			0.200	
F		0.38			0.015	
G			0.101			0.004
M		1.27			0.050	
M1		1.14			0.045	

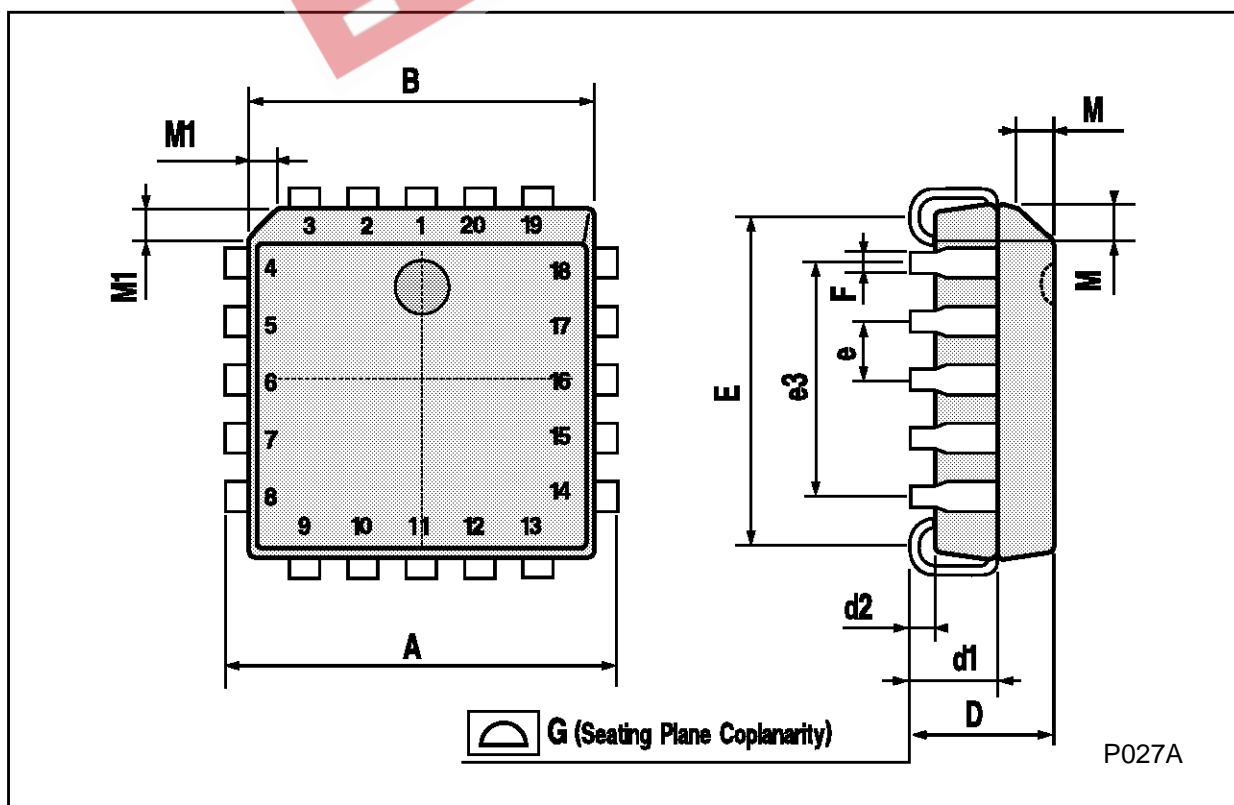

EEPW 电子產品世界
.com.cn

Information furnished is believed to be accurate and reliable. However, SGS-THOMSON Microelectronics assumes no responsibility for the consequences of use of such information nor for any infringement of patents or other rights of third parties which may result from its use. No license is granted by implication or otherwise under any patent or patent rights of SGS-THOMSON Microelectronics. Specifications mentioned in this publication are subject to change without notice. This publication supersedes and replaces all information previously supplied. SGS-THOMSON Microelectronics products are not authorized for use as critical components in life support devices or systems without express written approval of SGS-THOMSON Microelectronics.

© 1994 SGS-THOMSON Microelectronics - All Rights Reserved

SGS-THOMSON Microelectronics GROUP OF COMPANIES
Australia - Brazil - France - Germany - Hong Kong - Italy - Japan - Korea - Malaysia - Malta - Morocco - The Netherlands -
Singapore - Spain - Sweden - Switzerland - Taiwan - Thailand - United Kingdom - U.S.A