



SGS-THOMSON
MICROELECTRONICS

M54HCT240/241/244
M74HCT240/241/244

OCTAL BUS BUFFER WITH 3 STATE OUTPUTS
HCT240: INVERTED - HCT241/244 NON INVERTED

- HIGH SPEED
 $t_{PD} = 13 \text{ ns (TYP.) at } V_{CC} = 5\text{V}$
- LOW POWER DISSIPATION
 $I_{CC} = 4 \mu\text{A (MAX.) at } T_A = 25^\circ\text{C}$
- COMPATIBLE WITH TTL OUTPUTS
 $V_{IH} = 2\text{V (MIN.) } V_{IL} = 0.8\text{V (MAX)}$
- OUTPUT DRIVE CAPABILITY
15 LSTTL LOADS
- SYMMETRICAL OUTPUT IMPEDANCE
 $|I_{OH}| = I_{OL} = 6 \text{ mA (MIN)}$
- BALANCED PROPAGATION DELAYS
 $t_{PLH} = t_{PHL}$
- PIN AND FUNCTION COMPATIBLE
WITH 54/74LS240/241/244

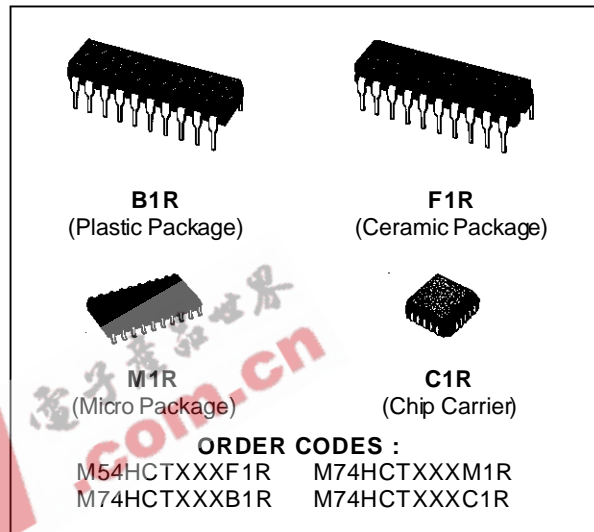

DESCRIPTION

The M54/74HCT240, HCT241 and HCT244 are high speed CMOS OCTAL BUS BUFFERS fabricated in silicon gate C²MOS technology. They have the same high speed performance of LSTTL combined with true CMOS low power consumption. The designer has a choice of select combination of inverting and non-inverting outputs, symmetrical \bar{G} (active low output control) input, and complementary G and \bar{G} inputs. Each control input governs four BUS BUFFERS. This integrated circuit has input and output

characteristics that are fully compatible with 54/74 LSTTL logic families. M54/74HCT devices are designed to directly interface HSC²MOS systems with TTL and NMOS components. They are also plug in replacements for LSTTL devices giving a reduction of power consumption. These devices are designed to be used with 3 state memory address drivers, etc. All inputs are equipped with protection circuits against static discharge and transient excess voltage.

PIN CONNECTION (top view)

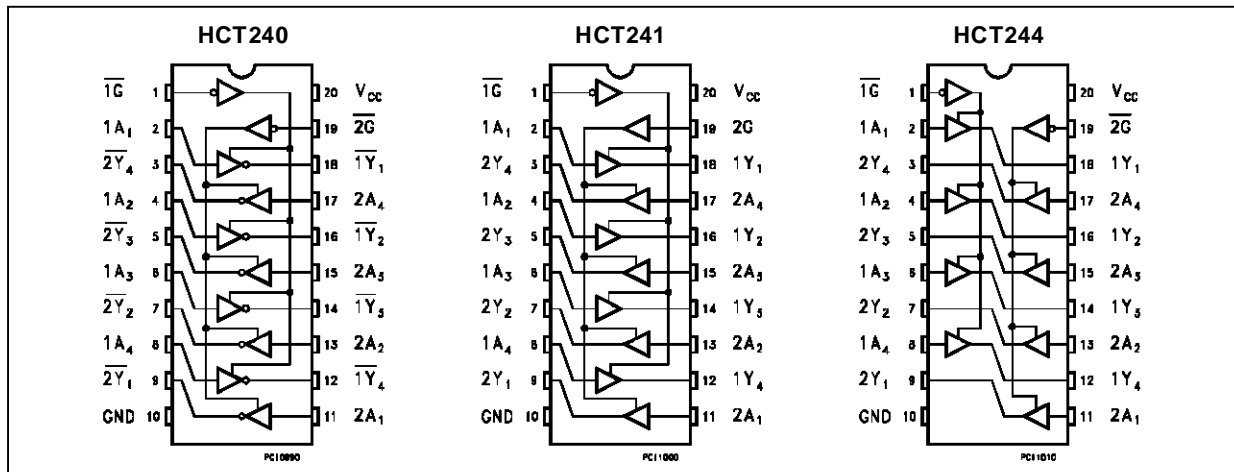

M54/M74HCT240/241/244

CHIP CARRIER

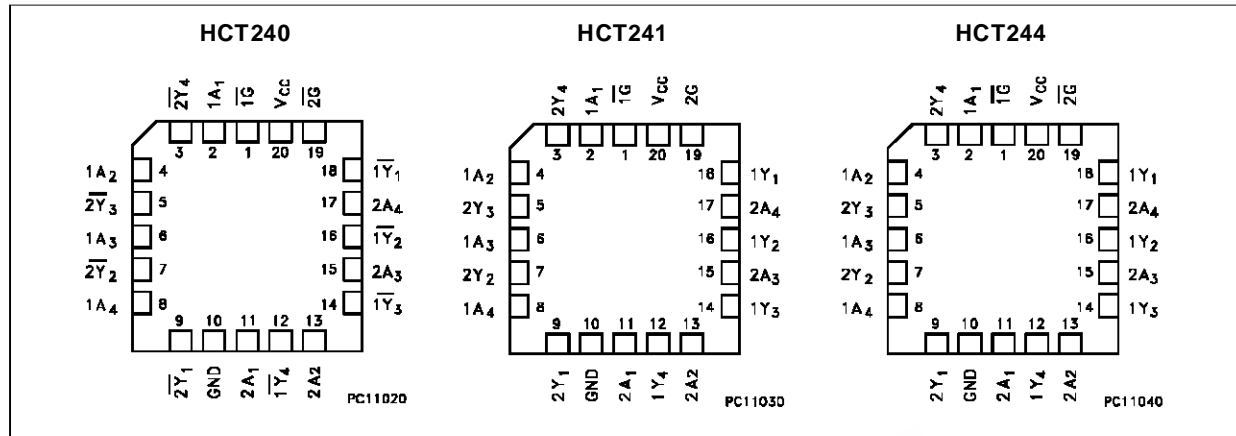

INPUT AND OUTPUT EQUIVALENT CIRCUIT

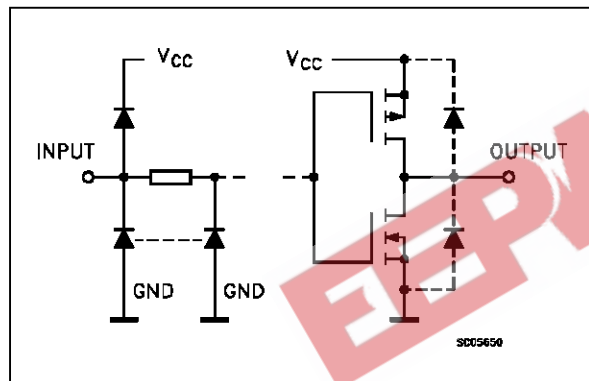

PIN DESCRIPTION (HCT240)

PIN No	SYMBOL	NAME AND FUNCTION
1	$\overline{1G}$	Output Enable Input
2, 4, 6, 8	1A1 to 1A4	Data Inputs
9, 7, 5, 3	2Y1 to 2Y4	Data Outputs
11, 13, 15, 17	2A1 to 2A4	Data Inputs
18, 16, 14, 12	1Y1 to 1Y4	Data Outputs
19	$\overline{2G}$	Output Enabel Input
10	GND	Ground (0V)
20	V _{cc}	Positive Supply Voltage

PIN DESCRIPTION (HCT241)

PIN No	SYMBOL	NAME AND FUNCTION
1	$\overline{1G}$	Output Enable Input
2, 4, 6, 8	1A1 to 1A4	Data Inputs
9, 7, 5, 3	2Y1 to 2Y4	Data Outputs
11, 13, 15, 17	2A1 to 2A4	Data Inputs
18, 16, 14, 12	1Y1 to 1Y4	Data Outputs
19	2G	Output Enabel Input
10	GND	Ground (0V)
20	V _{cc}	Positive Supply Voltage

PIN DESCRIPTION (HCT244)

PIN No	SYMBOL	NAME AND FUNCTION
1	$\overline{1G}$	Output Enable Input
2, 4, 6, 8	1A1 to 1A4	Data Inputs
9, 7, 5, 3	$\overline{2Y1}$ to $\overline{2Y4}$	Data Outputs
11, 13, 15, 17	2A1 to 2A4	Data Inputs
18, 16, 14, 12	$\overline{1Y1}$ to $\overline{1Y4}$	Data Outputs
19	$\overline{2G}$	Output Enabel Input
10	GND	Ground (0V)
20	V _{cc}	Positive Supply Voltage

IEC LOGIC SYMBOLS

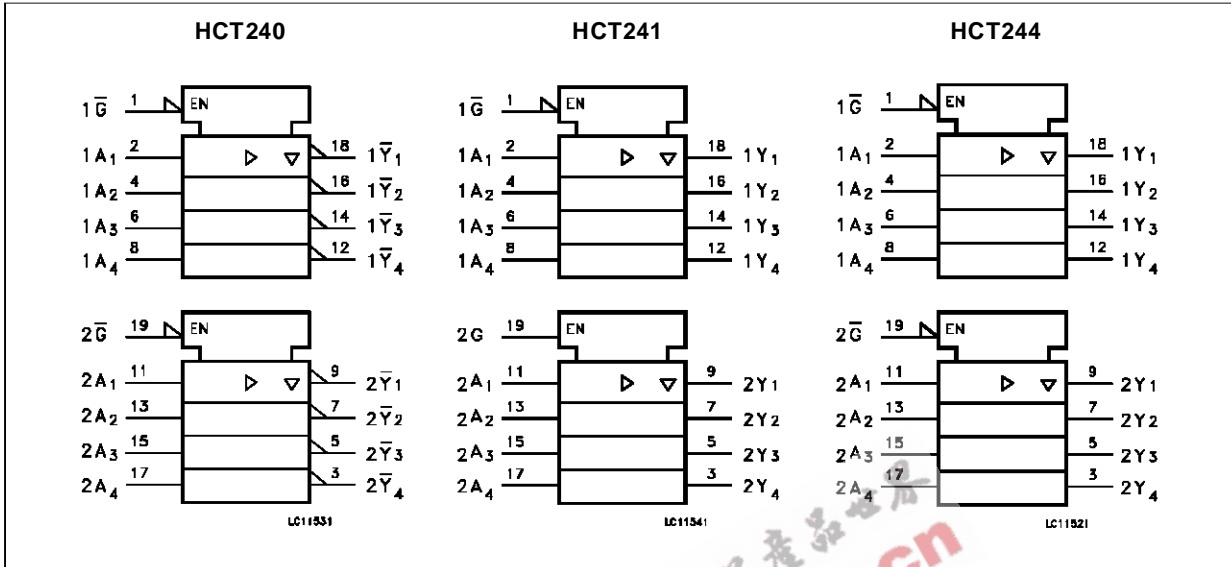

TRUTH TABLE

INPUT			OUTPUT		
Ḡ	G (HCT241)	A _n	Y _n (HCT240)	Y _n (HCT241)	Y _n (HCT244)
L	H	L	H	L	L
L	H	H	L	H	H
H	L	X	Z	Z	Z

X: "H" or "L"
Z: High impedance

CIRCUIT SCHEMATIC (1/8 PACKAGE)

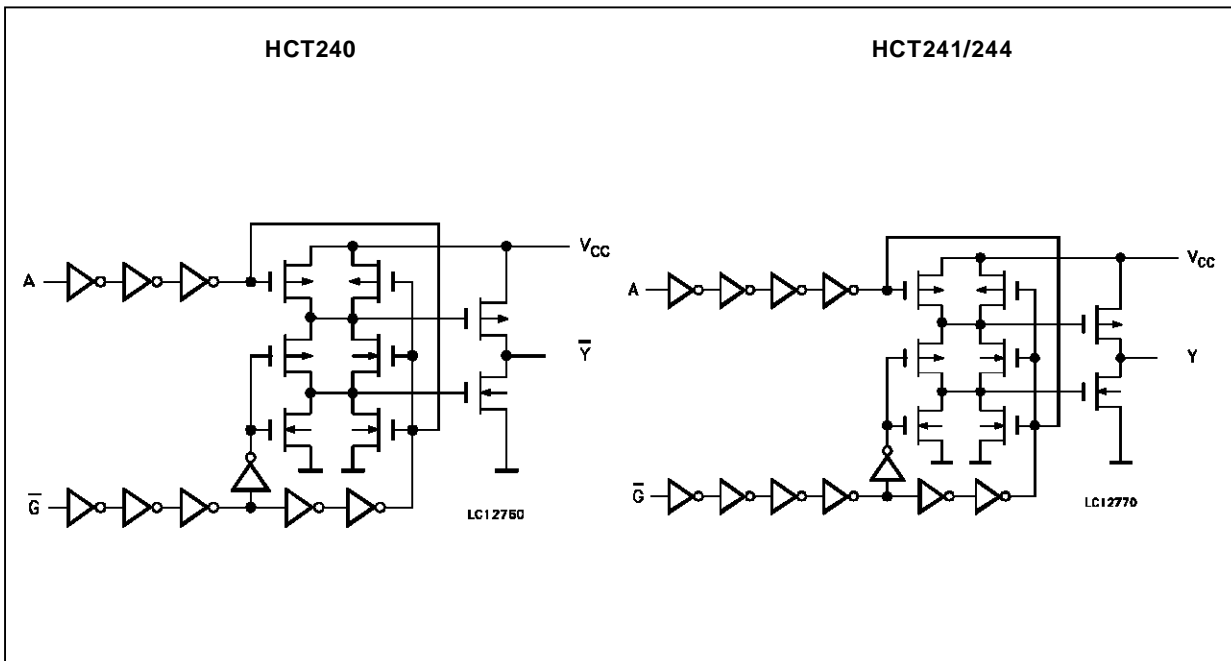

M54/M74HCT240/241/244

ABSOLUTE MAXIMUM RATINGS

Symbol	Parameter	Value	Unit
V _{CC}	Supply Voltage	-0.5 to +7	V
V _I	DC Input Voltage	-0.5 to V _{CC} + 0.5	V
V _O	DC Output Voltage	-0.5 to V _{CC} + 0.5	V
I _{IK}	DC Input Diode Current	± 20	mA
I _{OK}	DC Output Diode Current	± 20	mA
I _O	DC Output Source Sink Current Per Output Pin	± 35	mA
I _{CC} or I _{GND}	DC V _{CC} or Ground Current	± 70	mA
P _D	Power Dissipation	500 (*)	mW
T _{stg}	Storage Temperature	-65 to +150	°C
T _L	Lead Temperature (10 sec)	300	°C

Absolute Maximum Ratings are those values beyond which damage to the device may occur. Functional operation under these condition is not implied.

(*) 500 mW: ≅ 65 °C derate to 300 mW by 10mW/°C: 65 °C to 85 °C

RECOMMENDED OPERATING CONDITIONS

Symbol	Parameter	Value	Unit
V _{CC}	Supply Voltage	4.5 to 5.5	V
V _I	Input Voltage	0 to V _{CC}	V
V _O	Output Voltage	0 to V _{CC}	V
T _{op}	Operating Temperature: M54HC Series M74HC Series	-55 to +125 -40 to +85	°C °C
t _r , t _f	Input Rise and Fall Time (V _{CC} = 4.5 to 5.5V)	0 to 500	ns

DC SPECIFICATIONS

Symbol	Parameter	Test Conditions		Value						Unit		
		V _{CC} (V)		T _A = 25 °C 54HC and 74HC			-40 to 85 °C 74HC		-55 to 125 °C 54HC			
				Min.	Typ.	Max.	Min.	Max.	Min.		Max.	
V _{IH}	High Level Input Voltage	4.5 to 5.5		2.0			2.0		2.0		V	
V _{IL}	Low Level Input Voltage	4.5 to 5.5				0.8		0.8		0.8	V	
V _{OH}	High Level Output Voltage	4.5	V _I = V _{IH} or V _{IL}	I _O = -20 μA	4.4	4.5		4.4		4.4		V
				I _O = -6.0 mA	4.18	4.31		4.13		4.10		
V _{OL}	Low Level Output Voltage	4.5	V _I = V _{IH} or V _{IL}	I _O = 20 μA		0.0	0.1		0.1		0.1	V
				I _O = 6.0 mA		0.17	0.26		0.33		0.4	
I _I	Input Leakage Current	5.5	V _I = V _{CC} or GND				±0.1		±1		±1	μA
I _{CC}	Quiescent Supply Current	5.5	V _I = V _{CC} or GND				4		40		80	μA
ΔI _{CC}	Additional worst case supply current	5.5	Per Input pin V _I = 0.5V or 2.4V Other Inputs at V _{CC} or GND				2.0		2.9		3.0	mA

M54/M74HCT240/241/244

AC ELECTRICAL CHARACTERISTICS (C_L = 50 pF, Input t_r = t_f = 6 ns)

Symbol	Parameter	Test Conditions			Value						Unit	
		V _{CC} (V)	C _L (pF)	R _L (KΩ)	T _A = 25 °C 54HC and 74HC			-40 to 85 °C 74HC		-55 to 125 °C 54HC		
					Min.	Typ.	Max.	Min.	Max.	Min.		Max.
t _{TLH} t _{THL}	Output Transition Time	4.5	50			7	12		15		18	ns
t _{PLH} t _{PHL}	Propagation Delay Time	4.5	50			15	22		28		33	ns
		4.5	150			21	30		38		45	ns
t _{PLH} t _{PHL}	Propagation Delay Time	4.5	50			15	25		31		38	ns
		4.5	150			21	33		41		50	ns
t _{PZL} t _{PZH}	Output Enable Time	4.5	50	R _L = 1KΩ		17	30		38		45	ns
		4.5	150	R _L = 1KΩ		23	38		48		57	ns
t _{PLZ} t _{PHZ}	Output Disable Time	4.5	50	R _L = 1KΩ		16	30		38		45	ns
C _{IN}	Input Capacitance					5	10		10		10	pF
C _{OUT}	Output Capacitance					10						pF
C _{PD} (*)	Power Dissipation Capacitance			HCT240 HCT241/244		33 31						pF

(*) C_{PD} is defined as the value of the IC's internal equivalent capacitance which is calculated from the operating current consumption without load. (Refer to Test Circuit). Average operating current can be obtained by the following equation. I_{CC(OPR)} = C_{PD} • V_{CC} • f_{IN} + I_{CC}/8 (per circuit)

TEST CIRCUIT I_{CC} (Opr.)

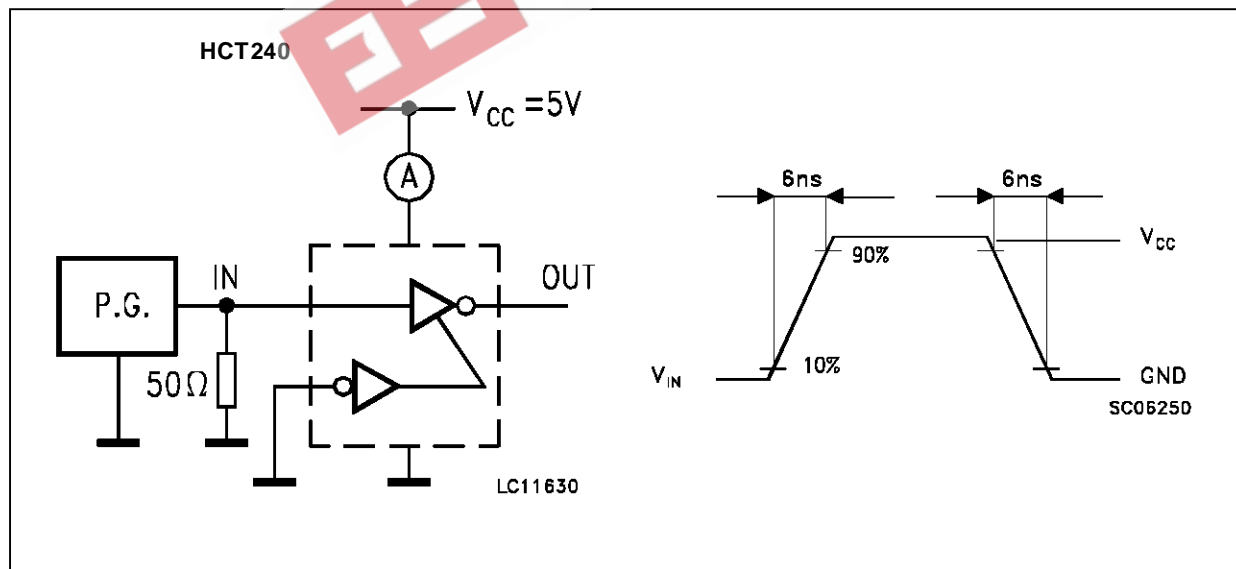

SWITCHING CHARACTERISTICS TEST WAVEFORM

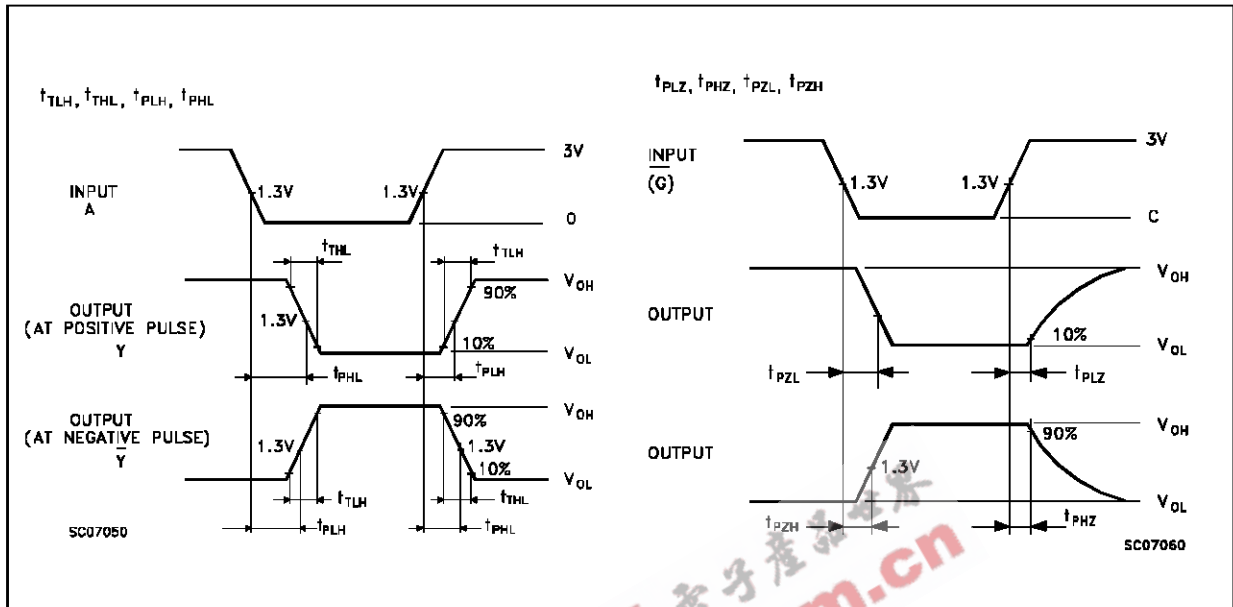

EEPW.com.cn 电子产业世界

M54/M74HCT240/241/244

Plastic DIP20 (0.25) MECHANICAL DATA

DIM.	mm			inch		
	MIN.	TYP.	MAX.	MIN.	TYP.	MAX.
a1	0.254			0.010		
B	1.39		1.65	0.055		0.065
b		0.45			0.018	
b1		0.25			0.010	
D			25.4			1.000
E		8.5			0.335	
e		2.54			0.100	
e3		22.86			0.900	
F			7.1			0.280
I			3.93			0.155
L		3.3			0.130	
Z			1.34			0.053

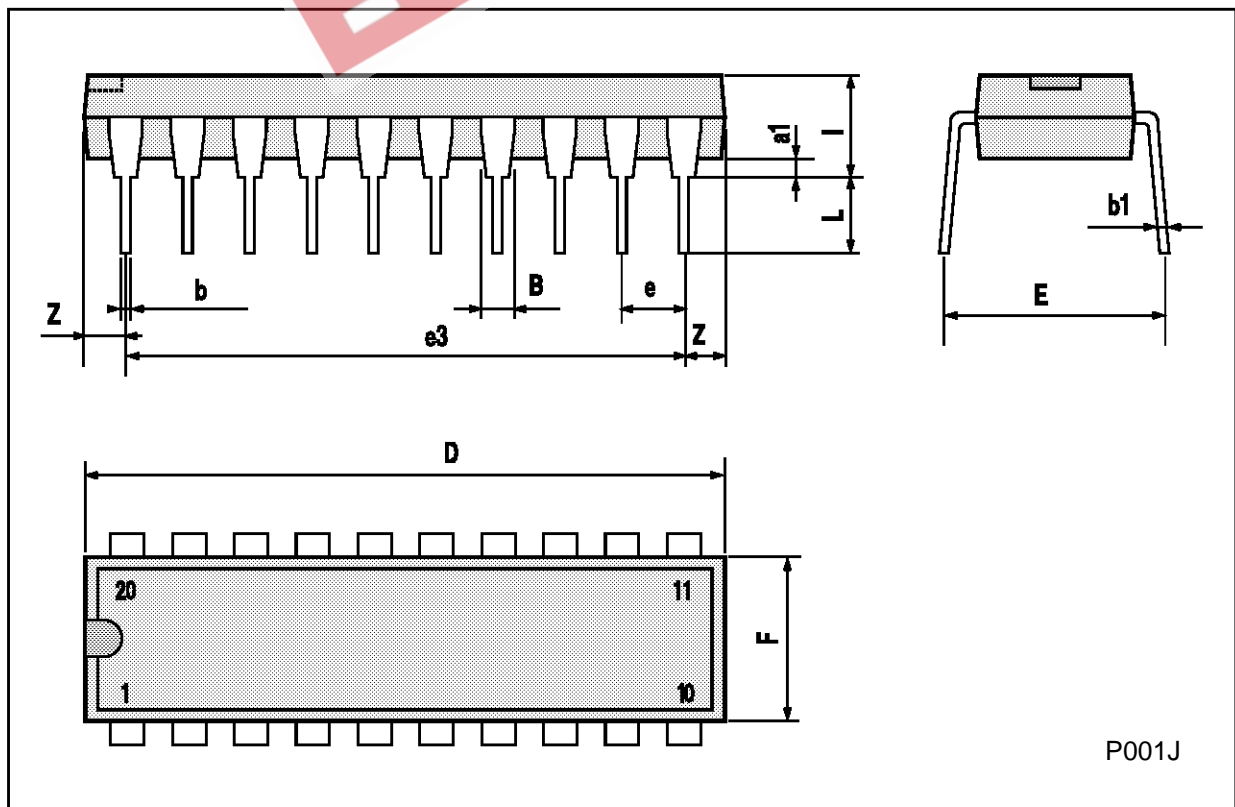

Ceramic DIP20 MECHANICAL DATA

DIM.	mm			inch		
	MIN.	TYP.	MAX.	MIN.	TYP.	MAX.
A			25			0.984
B			7.8			0.307
D		3.3			0.130	
E	0.5		1.78	0.020		0.070
e3		22.86			0.900	
F	2.29		2.79	0.090		0.110
G	0.4		0.55	0.016		0.022
I	1.27		1.52	0.050		0.060
L	0.22		0.31	0.009		0.012
M	0.51		1.27	0.020		0.050
N1	4° (min.), 15° (max.)					
P	7.9		8.13	0.311		0.320
Q			5.71			0.225

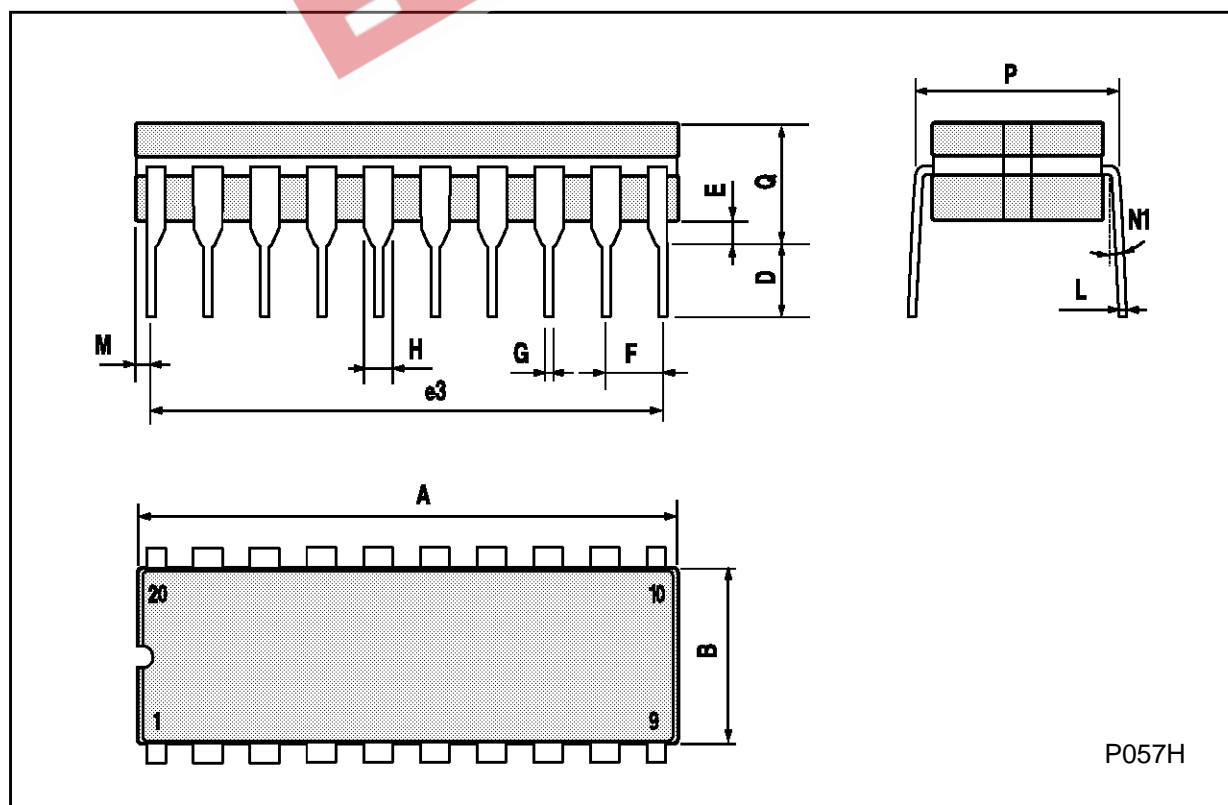

SO20 MECHANICAL DATA

DIM.	mm			inch		
	MIN.	TYP.	MAX.	MIN.	TYP.	MAX.
A			2.65			0.104
a1	0.10		0.20	0.004		0.007
a2			2.45			0.096
b	0.35		0.49	0.013		0.019
b1	0.23		0.32	0.009		0.012
C		0.50			0.020	
c1	45° (typ.)					
D	12.60		13.00	0.496		0.512
E	10.00		10.65	0.393		0.419
e		1.27			0.050	
e3		11.43			0.450	
F	7.40		7.60	0.291		0.299
L	0.50		1.27	0.19		0.050
M			0.75			0.029
S	8° (max.)					

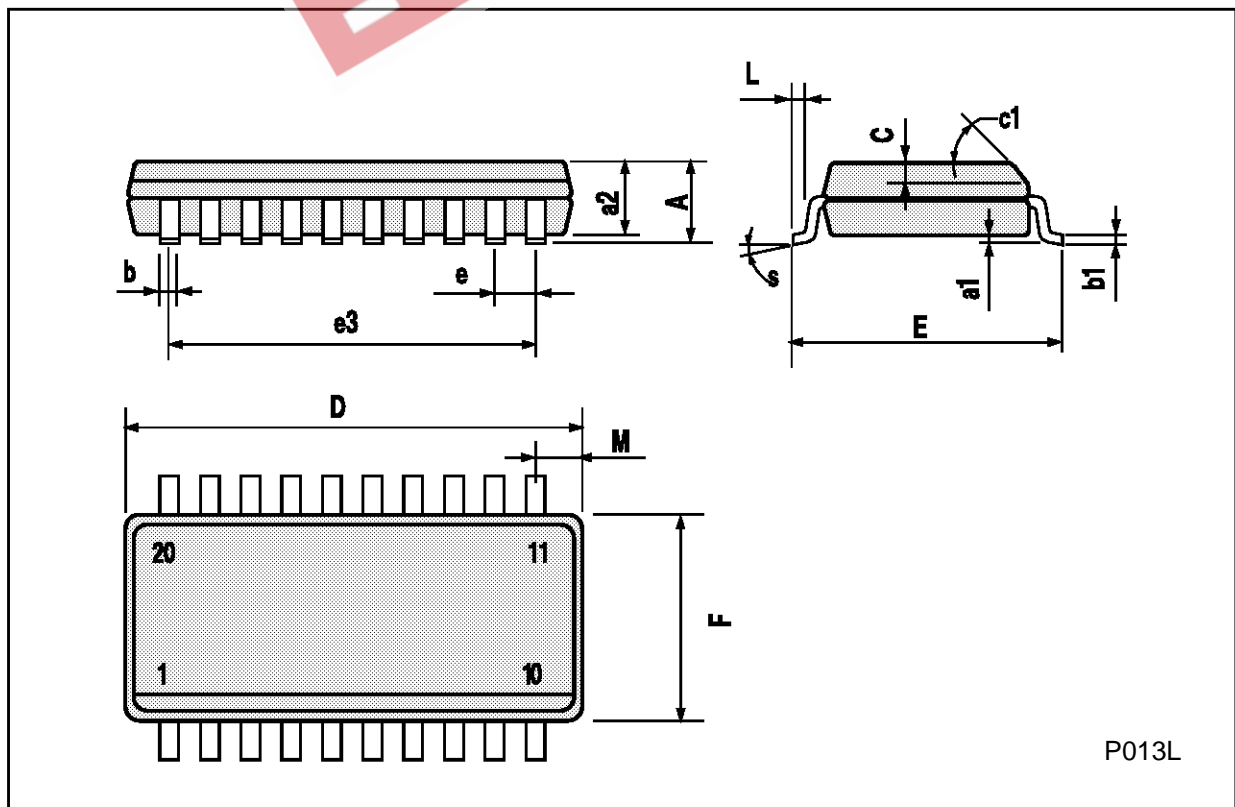

P013L

PLCC20 MECHANICAL DATA

DIM.	mm			inch		
	MIN.	TYP.	MAX.	MIN.	TYP.	MAX.
A	9.78		10.03	0.385		0.395
B	8.89		9.04	0.350		0.356
D	4.2		4.57	0.165		0.180
d1		2.54			0.100	
d2		0.56			0.022	
E	7.37		8.38	0.290		0.330
e		1.27			0.050	
e3		5.08			0.200	
F		0.38			0.015	
G			0.101			0.004
M		1.27			0.050	
M1		1.14			0.045	

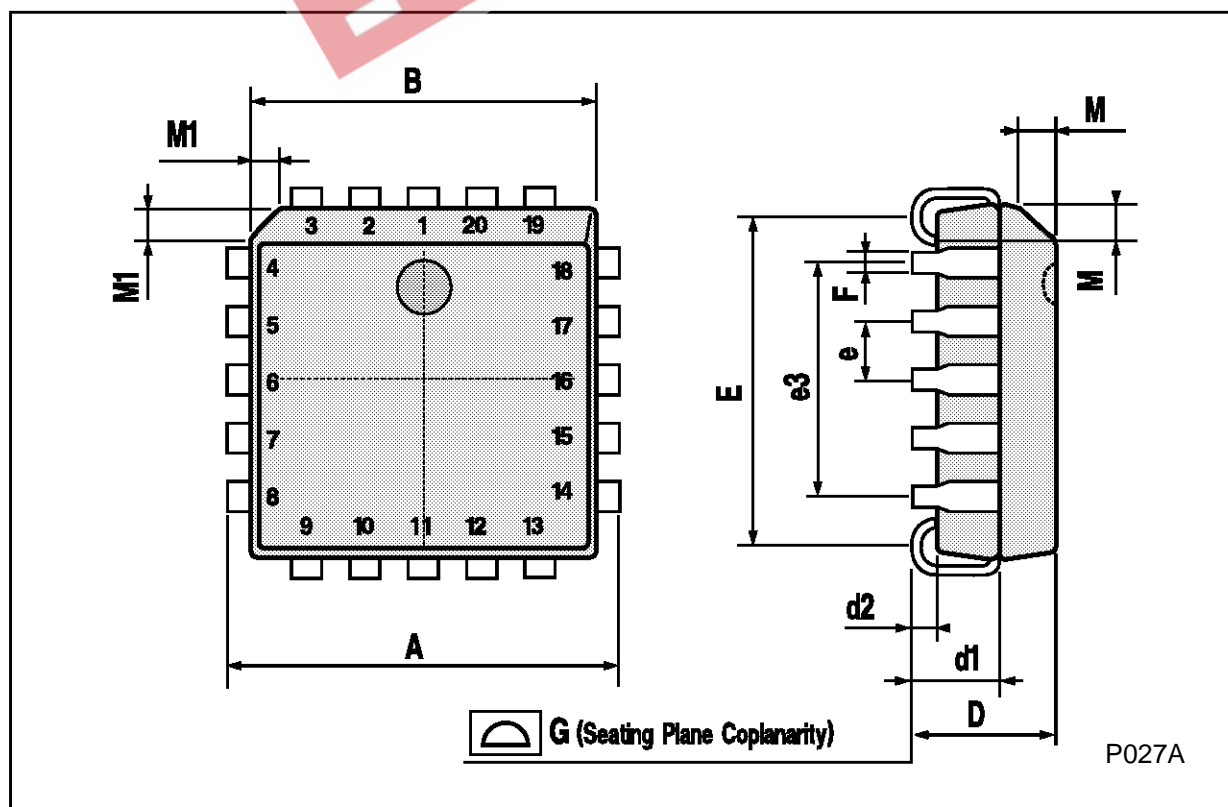

EEPW 电子產品世界
.com.cn

Information furnished is believed to be accurate and reliable. However, SGS-THOMSON Microelectronics assumes no responsibility for the consequences of use of such information nor for any infringement of patents or other rights of third parties which may result from its use. No license is granted by implication or otherwise under any patent or patent rights of SGS-THOMSON Microelectronics. Specifications mentioned in this publication are subject to change without notice. This publication supersedes and replaces all information previously supplied. SGS-THOMSON Microelectronics products are not authorized for use as critical components in life support devices or systems without express written approval of SGS-THOMSON Microelectronics.

© 1994 SGS-THOMSON Microelectronics - All Rights Reserved

SGS-THOMSON Microelectronics GROUP OF COMPANIES
Australia - Brazil - France - Germany - Hong Kong - Italy - Japan - Korea - Malaysia - Malta - Morocco - The Netherlands -
Singapore - Spain - Sweden - Switzerland - Taiwan - Thailand - United Kingdom - U.S.A