

HEX BUS BUFFER (3-STATE)
HC367 NON INVERTING, HC368 INVERTING

- HIGH SPEED
 $t_{PD} = 11 \text{ ns (TYP.) AT } V_{CC} = 5 \text{ V}$
- LOW POWER DISSIPATION
 $I_{CC} = 4 \mu\text{A (MAX.) AT } T_A = 25 \text{ }^\circ\text{C}$
- HIGH NOISE IMMUNITY
 $V_{NIH} = V_{NIL} = 28 \% V_{CC} \text{ (MIN.)}$
- OUTPUT DRIVE CAPABILITY
 15 LSTTL LOADS
- SYMMETRICAL OUTPUT IMPEDANCE
 $|I_{OH}| = I_{OL} = 6 \text{ mA (MIN.)}$
- BALANCED PROPAGATION DELAYS
 $t_{PLH} = t_{PHL}$
- WIDE OPERATING VOLTAGE RANGE
 $V_{CC} \text{ (OPR)} = 2 \text{ V TO } 6 \text{ V}$
- PIN AND FUNCTION COMPATIBLE WITH
 54/74LS367/368

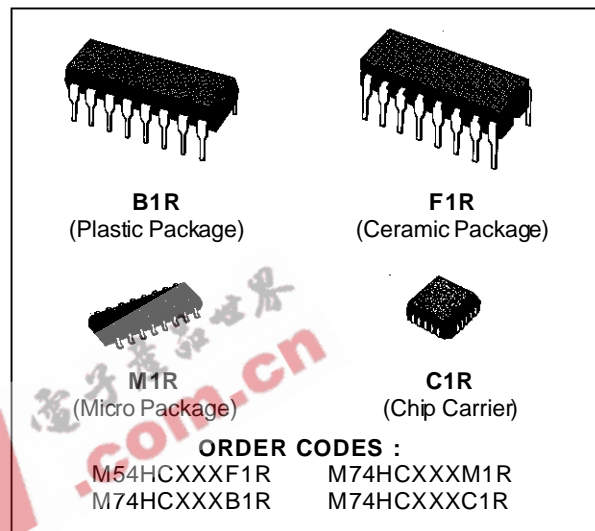

DESCRIPTION

The M54/74HC367 and the M54/74HC368 are high speed CMOS HEX BUS BUFFER (3-STATE) fabricated in silicon gate C²MOS technology. They have the same high speed performance of LSTTL combined with true CMOS low power consumption. These devices contain six buffers, four buffers are controlled by an enable input ($\overline{G1}$) and the other two buffers are controlled by the other enable input ($\overline{G2}$); the outputs of each buffer group are enabled when $\overline{G1}$ and/or $\overline{G2}$ inputs are held low, and when held high these outputs are disabled to be high-impedance.

These outputs are capable of driving up to 15 LSTTL loads. The designer has a choice of non-inverting outputs (HC367) and inverting outputs (HC368).

All inputs are equipped with protection circuits against static discharge and transient excess voltage.

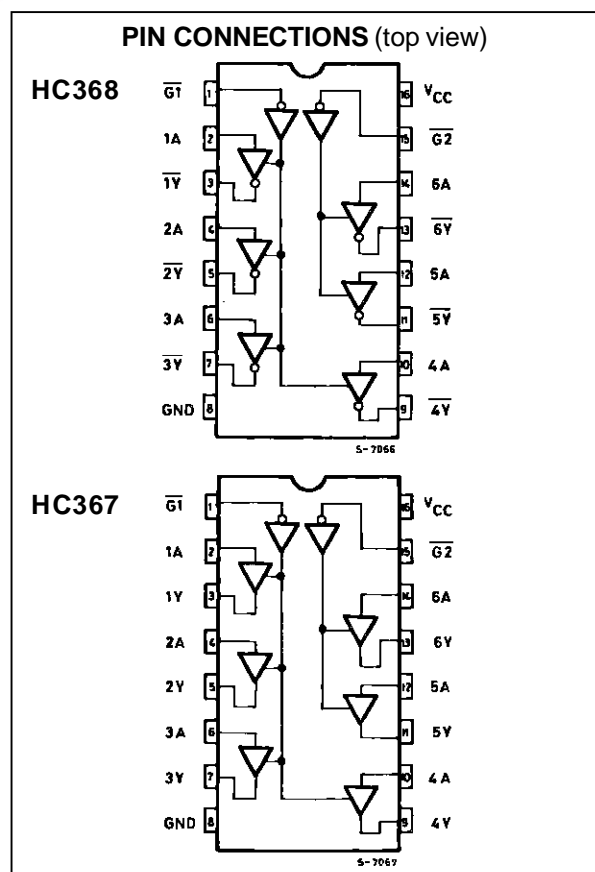

M54/M74HC367/368

INPUT AND OUTPUT EQUIVALENT CIRCUIT

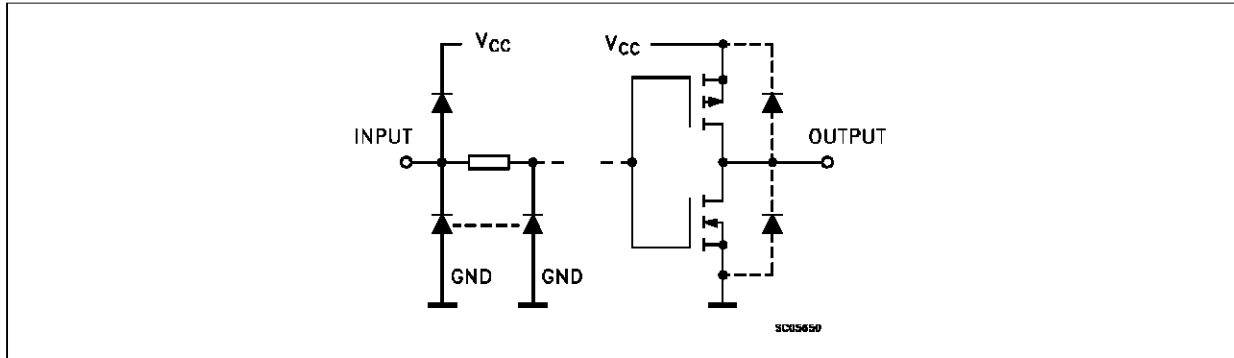

CHIP CARRIER

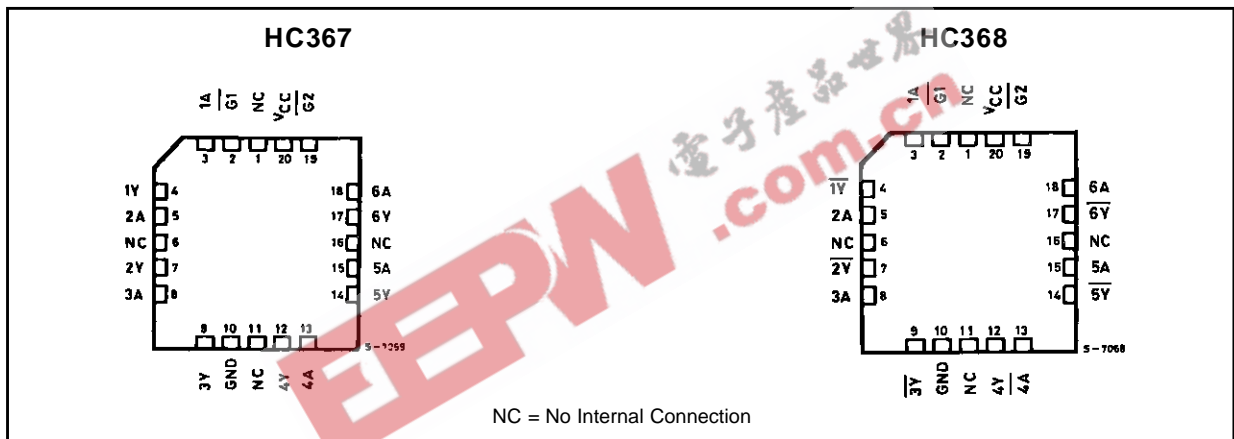

TRUTH TABLE

| INPUTS | | OUTPUTS | |
|----------------|-------|-------------|------------------------|
| \overline{G} | A_n | Y_n (367) | \overline{Y}_n (368) |
| L | L | L | H |
| L | H | H | L |
| H | X | Z | Z |

X = DON'T CARE Z = HIGH IMPEDANCE

PIN DESCRIPTION (HC367)

| PIN No | SYMBOL | NAME AND FUNCTION |
|---------------------|--------------------------------|-------------------------|
| 1, 15 | $\overline{G1}, \overline{G2}$ | Output Enable Inputs |
| 2, 4, 6, 10, 12, 14 | 1A to 6A | Data Inputs |
| 3, 5, 7, 9, 11, 13 | 1Y to 6Y | Data Outputs |
| 8 | GND | Ground (0V) |
| 16 | V _{CC} | Positive Supply Voltage |

PIN DESCRIPTION (HC368)

| PIN No | SYMBOL | NAME AND FUNCTION |
|---------------------|------------------------------------|-------------------------|
| 1, 15 | $\overline{G1}, \overline{G2}$ | Output Enable Inputs |
| 2, 4, 6, 10, 12, 14 | 1A to 6A | Data Inputs |
| 3, 5, 7, 9, 11, 13 | $\overline{1Y}$ to $\overline{6Y}$ | Data Outputs |
| 8 | GND | Ground (0V) |
| 16 | V _{CC} | Positive Supply Voltage |

IEC LOGIC SYMBOL

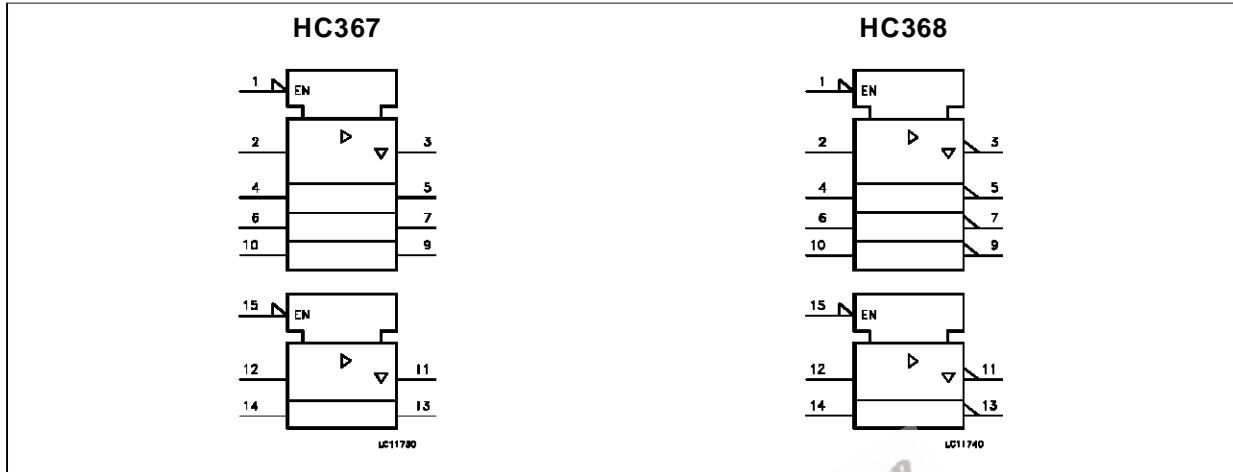

ABSOLUTE MAXIMUM RATINGS

| Symbol | Parameter | Value | Unit |
|-----------------------|--|------------------------|-------------|
| V_{CC} | Supply Voltage | -0.5 to +7 | V |
| V_I | DC Input Voltage | -0.5 to $V_{CC} + 0.5$ | V |
| V_O | DC Output Voltage | -0.5 to $V_{CC} + 0.5$ | V |
| I_{IK} | DC Input Diode Current | ± 20 | mA |
| I_{OK} | DC Output Diode Current | ± 20 | mA |
| I_O | DC Output Source Sink Current Per Output Pin | ± 35 | mA |
| I_{CC} or I_{GND} | DC V_{CC} or Ground Current | ± 70 | mA |
| P_D | Power Dissipation | 500 (*) | mW |
| T_{stg} | Storage Temperature | -65 to +150 | $^{\circ}C$ |
| T_L | Lead Temperature (10 sec) | 300 | $^{\circ}C$ |

Absolute Maximum Ratings are those values beyond which damage to the device may occur. Functional operation under these condition is not implied.
 (*) 500 mW: $\cong 65^{\circ}C$ derate to 300 mW by 10mW/ $^{\circ}C$: 65 $^{\circ}C$ to 85 $^{\circ}C$

RECOMMENDED OPERATING CONDITIONS

| Symbol | Parameter | Value | Unit | |
|------------|---|---|-----------------------------------|----|
| V_{CC} | Supply Voltage | 2 to 6 | V | |
| V_I | Input Voltage | 0 to V_{CC} | V | |
| V_O | Output Voltage | 0 to V_{CC} | V | |
| T_{op} | Operating Temperature: M54HC Series M74HC Series | -55 to +125 -40 to +85 | $^{\circ}C$ $^{\circ}C$ | |
| t_r, t_f | Input Rise and Fall Time | $V_{CC} = 2\text{ V}$ $V_{CC} = 4.5\text{ V}$ $V_{CC} = 6\text{ V}$ | 0 to 1000 0 to 500 0 to 400 | ns |

M54/M74HC367/368

DC SPECIFICATIONS

| Symbol | Parameter | Test Conditions | | Value | | | | | | Unit | |
|-----------------|----------------------------------|------------------------|--|---|-------------------------|------|----------------------|------|-----------------------|------|------|
| | | V _{CC} (V) | | T _A = 25 °C 54HC and 74HC | | | -40 to 85 °C 74HC | | -55 to 125 °C 54HC | | |
| | | | | Min. | Typ. | Max. | Min. | Max. | Min. | | Max. |
| V _{IH} | High Level Input Voltage | 2.0 | | 1.5 | | | 1.5 | | 1.5 | | V |
| | | 4.5 | | 3.15 | | | 3.15 | | 3.15 | | |
| | | 6.0 | | 4.2 | | | 4.2 | | 4.2 | | |
| V _{IL} | Low Level Input Voltage | 2.0 | | | | 0.5 | | 0.5 | | 0.5 | V |
| | | 4.5 | | | | 1.35 | | 1.35 | | 1.35 | |
| | | 6.0 | | | | 1.8 | | 1.8 | | 1.8 | |
| V _{OH} | High Level Output Voltage | 2.0 | V _I = V _{IH} or V _{IL} | I _O = -20 μA | 1.9 | 2.0 | | 1.9 | | 1.9 | V |
| | | 4.5 | | | 4.4 | 4.5 | | 4.4 | | 4.4 | |
| | | 6.0 | | | 5.9 | 6.0 | | 5.9 | | 5.9 | |
| | | 4.5 | I _O = -6.0 mA | 4.18 | 4.31 | | 4.13 | | 4.10 | | |
| | | 6.0 | | I _O = -7.8 mA | 5.68 | 5.8 | | 5.63 | | 5.60 | |
| V _{OL} | Low Level Output Voltage | 2.0 | V _I = V _{IH} or V _{IL} | I _O = 20 μA | | 0.0 | 0.1 | | 0.1 | | V |
| | | 4.5 | | | | 0.0 | 0.1 | | 0.1 | | |
| | | 6.0 | | | | 0.0 | 0.1 | | 0.1 | | |
| | | 4.5 | | I _O = 6.0 mA | 0.17 | 0.26 | | 0.33 | | 0.40 | |
| | | 6.0 | | | I _O = 7.8 mA | 0.18 | 0.26 | | 0.33 | | |
| I _I | Input Leakage Current | 6.0 | V _I = V _{CC} or GND | | | ±0.1 | | ±1 | | ±1 | μA |
| I _{OZ} | 3 State Output Off State Current | 6.0 | V _I = V _{IH} or V _{IL} V _O = V _{CC} or GND | | | ±0.5 | | ±5 | | ±10 | μA |
| I _{CC} | Quiescent Supply Current | 6.0 | V _I = V _{CC} or GND | | | 4 | | 40 | | 80 | μA |

AC ELECTRICAL CHARACTERISTICS ($C_L = 50$ pF, Input $t_r = t_f = 6$ ns)

| Symbol | Parameter | Test Conditions | | | Value | | | | | | Unit | |
|--------------------------------------|-------------------------------|---------------------|---------------------|-----------------------|---|------|------|----------------------|------|-----------------------|------|------|
| | | V _{CC} (V) | C _L (pF) | | T _A = 25 °C 54HC and 74HC | | | -40 to 85 °C 74HC | | -55 to 125 °C 54HC | | |
| | | | | | Min. | Typ. | Max. | Min. | Max. | Min. | | Max. |
| t _{TLH} t _{THL} | Output Transition Time | 2.0 | 50 | | | 25 | 60 | | 75 | | 90 | ns |
| | | 4.5 | | | 7 | 12 | | 15 | | 18 | | |
| | | 6.0 | | | 6 | 10 | | 13 | | 15 | | |
| t _{PLH} t _{PHL} | Propagation Delay Time | 2.0 | 50 | | 30 | 85 | | 105 | | 130 | ns | |
| | | 4.5 | | | 10 | 17 | | 21 | | 26 | | |
| | | 6.0 | | | 9 | 14 | | 18 | | 22 | | |
| | | 2.0 | 150 | | 42 | 105 | | 130 | | 160 | ns | |
| | | 4.5 | | | 14 | 21 | | 26 | | 32 | | |
| | | 6.0 | | | 12 | 18 | | 22 | | 27 | | |
| t _{PZL} t _{PZH} | Output Enable Time | 2.0 | 50 | R _L = 1 KΩ | | 36 | 90 | | 115 | | 135 | ns |
| | | 4.5 | | | | 11 | 18 | | 23 | | 27 | |
| | | 6.0 | | | | 9 | 15 | | 20 | | 23 | |
| | | 2.0 | 150 | R _L = 1 KΩ | | 49 | 110 | | 140 | | 165 | ns |
| | | 4.5 | | | | 15 | 22 | | 28 | | 33 | |
| | | 6.0 | | | | 13 | 19 | | 24 | | 28 | |
| t _{PLZ} t _{PHZ} | Output Disable Time | 2.0 | 50 | R _L = 1 KΩ | | 32 | 95 | | 120 | | 145 | ns |
| | | 4.5 | | | | 14 | 19 | | 24 | | 29 | |
| | | 6.0 | | | | 12 | 16 | | 20 | | 25 | |
| C _{IN} | Input Capacitance | | | | | 5 | 10 | | 10 | | 10 | pF |
| C _{PD} (*) | Power Dissipation Capacitance | | | | | 33 | | | | | | pF |

(*) C_{PD} is defined as the value of the IC's internal equivalent capacitance which is calculated from the operating current consumption without load. (Refer to Test Circuit). Average operating current can be obtained by the following equation. $I_{CC(opr)} = C_{PD} \cdot V_{CC} \cdot f_{IN} + I_{CC}/6$ (per Channel)

TEST CIRCUIT I_{CC} (Opr.)

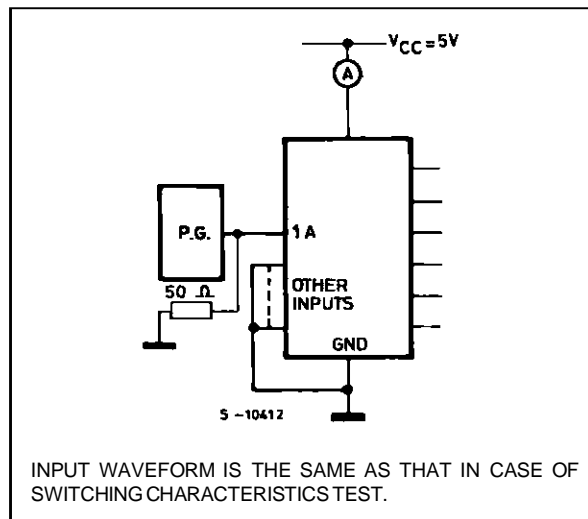

C_{PD} CALCULATION

C_{PD} is to be calculated with the following formula by using the measured value of I_{CC} (opr.) in the test circuit opposite.

$$C_{PD} = \frac{I_{CC(opr)}}{f_{IN} \times V_{CC}}$$

In determining the typical value of C_{PD}, a relatively high frequency of 1 MHz was applied to f_{IN}, in order to eliminate any error caused by the quiescent supply current.

SWITCHING CHARACTERISTICS TEST WAVEFORM

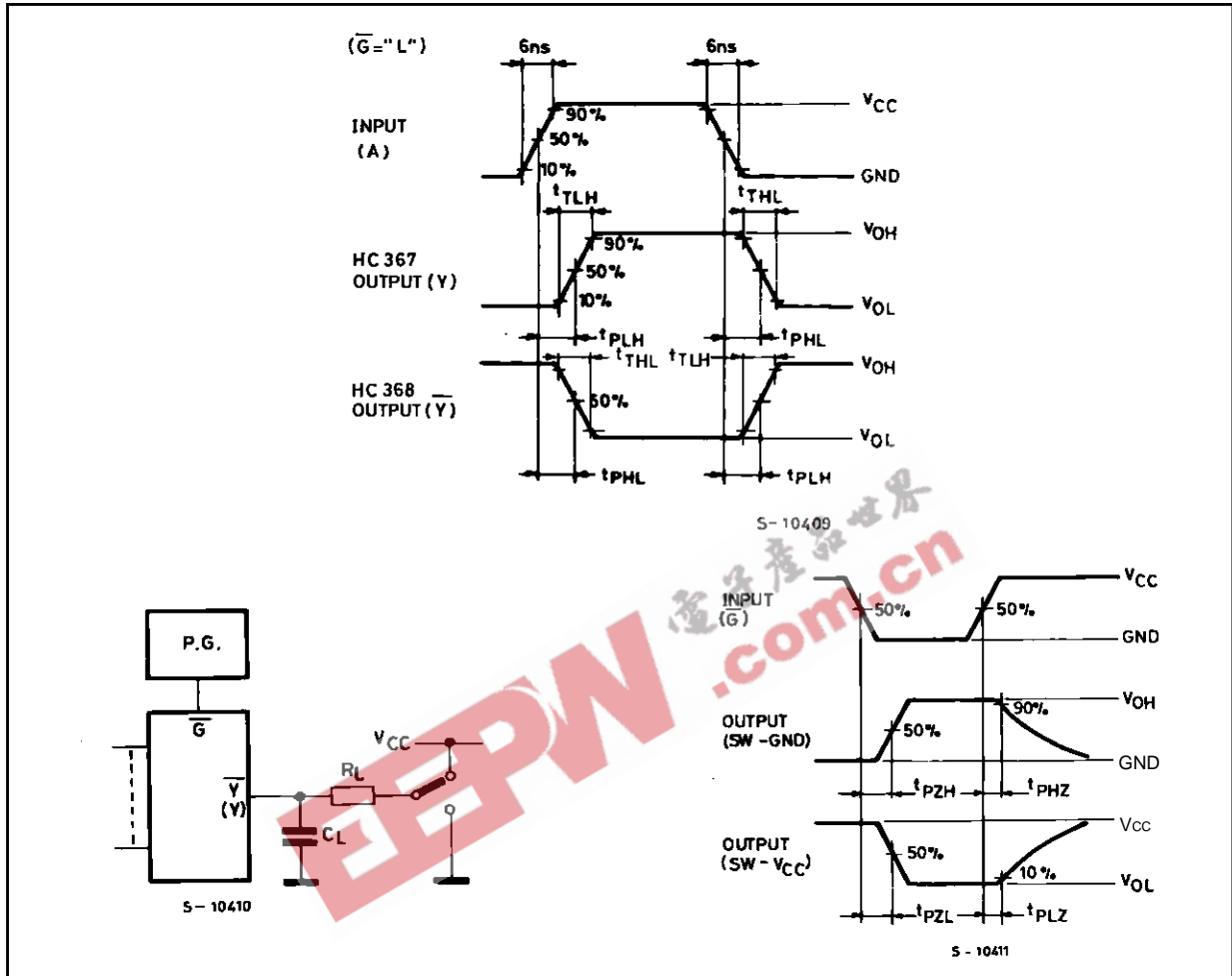

Note : Such a logic level shall be applied to each input that the output voltage stays in the apposite side to the switch connection level, when the output is enable.

Plastic DIP16 (0.25) MECHANICAL DATA

| DIM. | mm | | | inch | | |
|------|------|-------|------|-------|-------|-------|
| | MIN. | TYP. | MAX. | MIN. | TYP. | MAX. |
| a1 | 0.51 | | | 0.020 | | |
| B | 0.77 | | 1.65 | 0.030 | | 0.065 |
| b | | 0.5 | | | 0.020 | |
| b1 | | 0.25 | | | 0.010 | |
| D | | | 20 | | | 0.787 |
| E | | 8.5 | | | 0.335 | |
| e | | 2.54 | | | 0.100 | |
| e3 | | 17.78 | | | 0.700 | |
| F | | | 7.1 | | | 0.280 |
| I | | | 5.1 | | | 0.201 |
| L | | 3.3 | | | 0.130 | |
| Z | | | 1.27 | | | 0.050 |

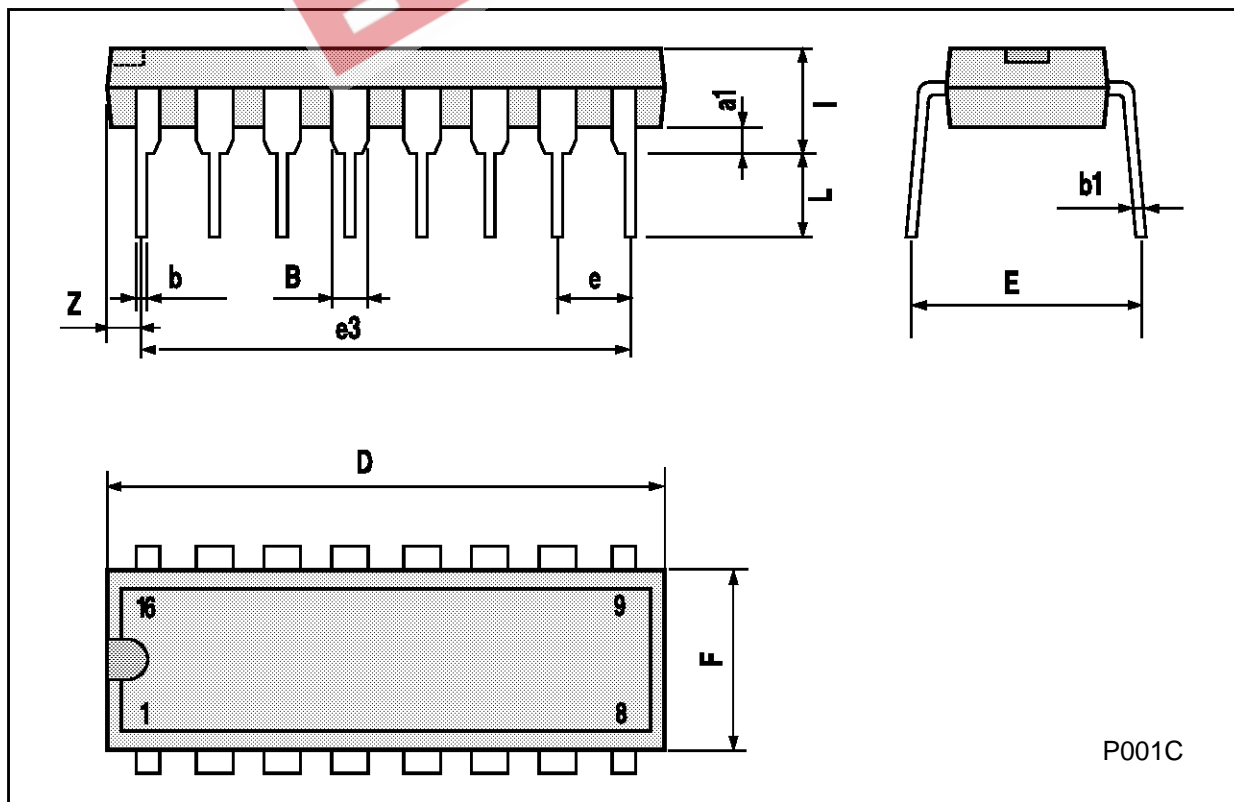

M54/M74HC367/368

Ceramic DIP16/1 MECHANICAL DATA

| DIM. | mm | | | inch | | |
|------|------|-------|------|-------|-------|-------|
| | MIN. | TYP. | MAX. | MIN. | TYP. | MAX. |
| A | | | 20 | | | 0.787 |
| B | | | 7 | | | 0.276 |
| D | | 3.3 | | | 0.130 | |
| E | 0.38 | | | 0.015 | | |
| e3 | | 17.78 | | | 0.700 | |
| F | 2.29 | | 2.79 | 0.090 | | 0.110 |
| G | 0.4 | | 0.55 | 0.016 | | 0.022 |
| H | 1.17 | | 1.52 | 0.046 | | 0.060 |
| L | 0.22 | | 0.31 | 0.009 | | 0.012 |
| M | 0.51 | | 1.27 | 0.020 | | 0.050 |
| N | | | 10.3 | | | 0.406 |
| P | 7.8 | | 8.05 | 0.307 | | 0.317 |
| Q | | | 5.08 | | | 0.200 |

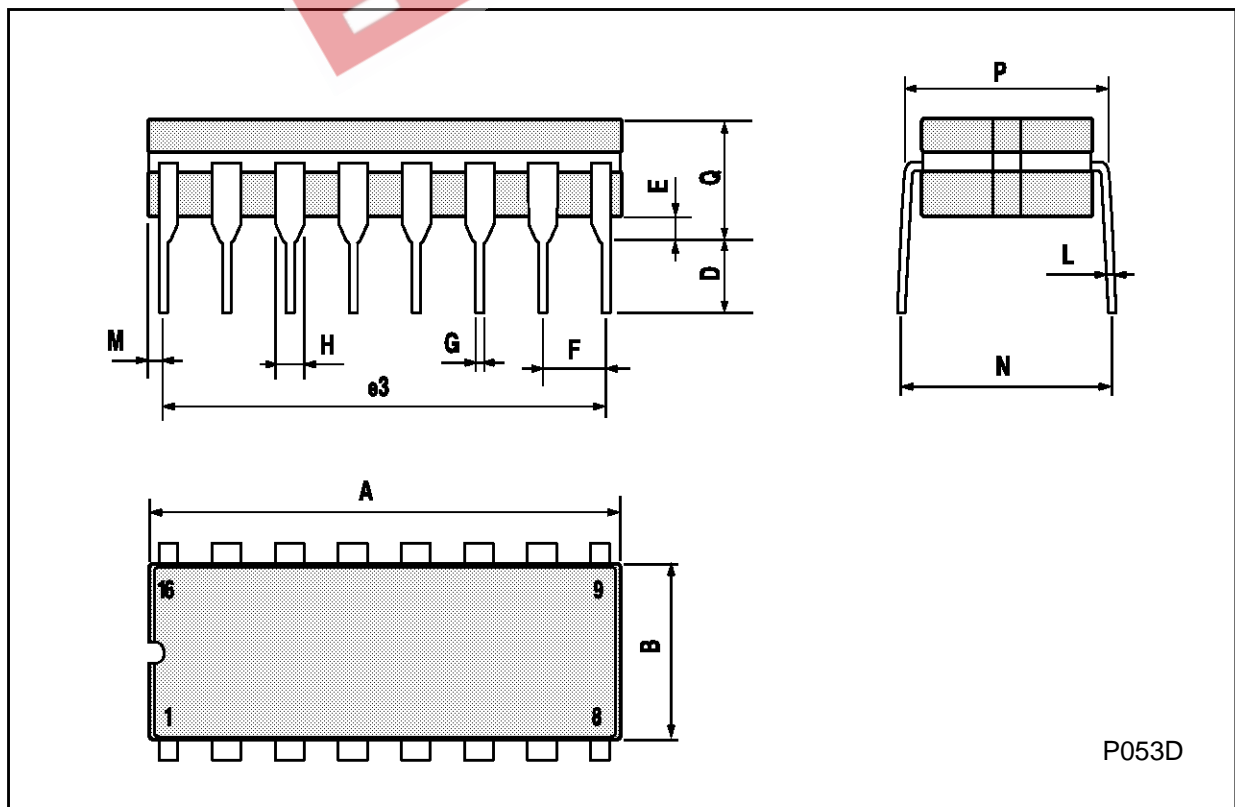

P053D

SO16 (Narrow) MECHANICAL DATA

| DIM. | mm | | | inch | | |
|------|------------|------|------|-------|-------|-------|
| | MIN. | TYP. | MAX. | MIN. | TYP. | MAX. |
| A | | | 1.75 | | | 0.068 |
| a1 | 0.1 | | 0.2 | 0.004 | | 0.007 |
| a2 | | | 1.65 | | | 0.064 |
| b | 0.35 | | 0.46 | 0.013 | | 0.018 |
| b1 | 0.19 | | 0.25 | 0.007 | | 0.010 |
| C | | 0.5 | | | 0.019 | |
| c1 | 45° (typ.) | | | | | |
| D | 9.8 | | 10 | 0.385 | | 0.393 |
| E | 5.8 | | 6.2 | 0.228 | | 0.244 |
| e | | 1.27 | | | 0.050 | |
| e3 | | 8.89 | | | 0.350 | |
| F | 3.8 | | 4.0 | 0.149 | | 0.157 |
| G | 4.6 | | 5.3 | 0.181 | | 0.208 |
| L | 0.5 | | 1.27 | 0.019 | | 0.050 |
| M | | | 0.62 | | | 0.024 |
| S | 8° (max.) | | | | | |

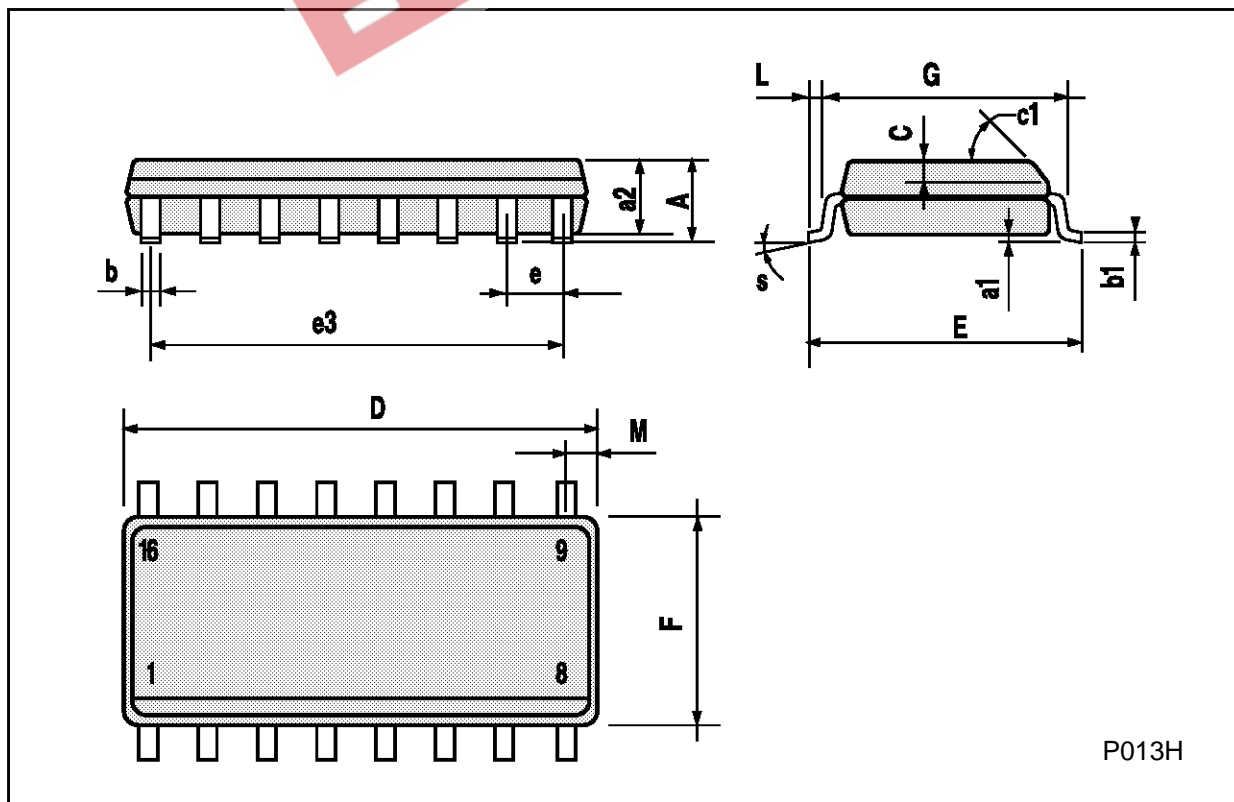

M54/M74HC367/368

PLCC20 MECHANICAL DATA

| DIM. | mm | | | inch | | |
|------|------|------|-------|-------|-------|-------|
| | MIN. | TYP. | MAX. | MIN. | TYP. | MAX. |
| A | 9.78 | | 10.03 | 0.385 | | 0.395 |
| B | 8.89 | | 9.04 | 0.350 | | 0.356 |
| D | 4.2 | | 4.57 | 0.165 | | 0.180 |
| d1 | | 2.54 | | | 0.100 | |
| d2 | | 0.56 | | | 0.022 | |
| E | 7.37 | | 8.38 | 0.290 | | 0.330 |
| e | | 1.27 | | | 0.050 | |
| e3 | | 5.08 | | | 0.200 | |
| F | | 0.38 | | | 0.015 | |
| G | | | 0.101 | | | 0.004 |
| M | | 1.27 | | | 0.050 | |
| M1 | | 1.14 | | | 0.045 | |

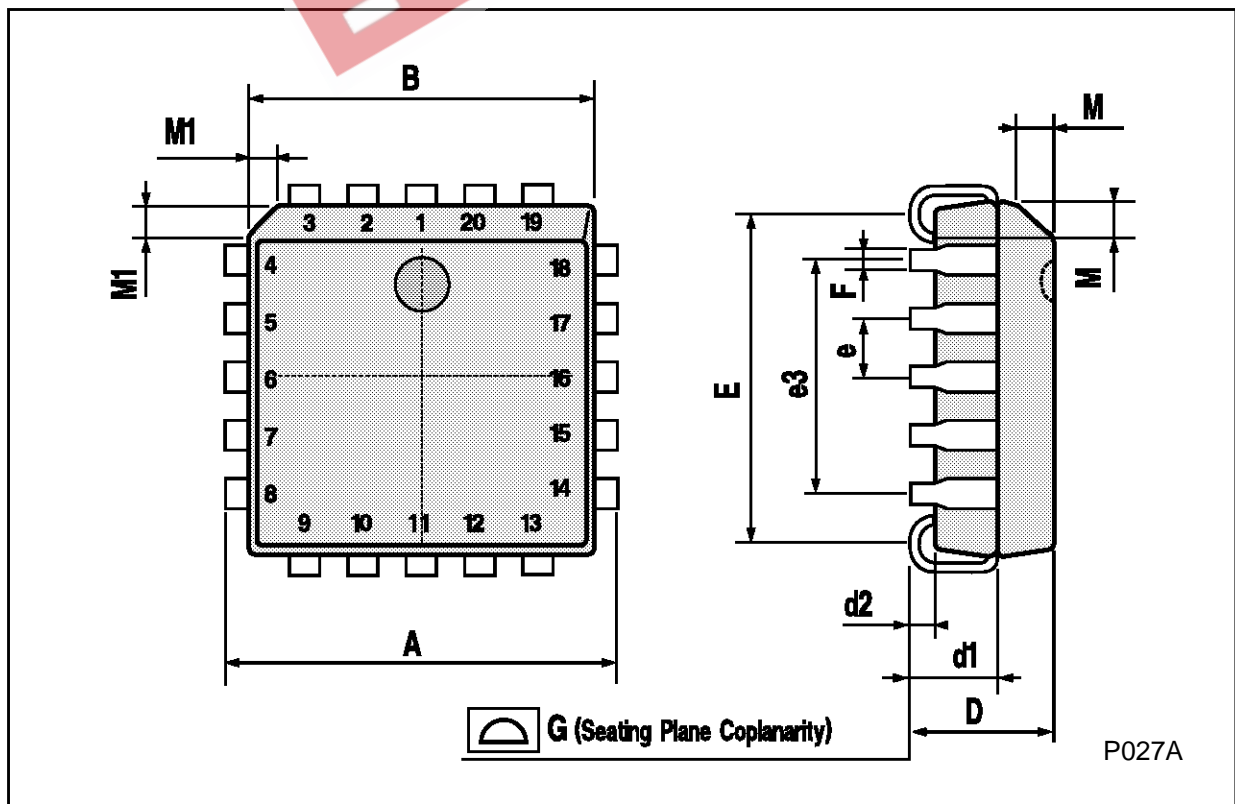

EEPW 电子產品世界
.com.cn

Information furnished is believed to be accurate and reliable. However, SGS-THOMSON Microelectronics assumes no responsibility for the consequences of use of such information nor for any infringement of patents or other rights of third parties which may result from its use. No license is granted by implication or otherwise under any patent or patent rights of SGS-THOMSON Microelectronics. Specifications mentioned in this publication are subject to change without notice. This publication supersedes and replaces all information previously supplied. SGS-THOMSON Microelectronics products are not authorized for use as critical components in life support devices or systems without express written approval of SGS-THOMSON Microelectronics.

© 1994 SGS-THOMSON Microelectronics - All Rights Reserved

SGS-THOMSON Microelectronics GROUP OF COMPANIES

Australia - Brazil - France - Germany - Hong Kong - Italy - Japan - Korea - Malaysia - Malta - Morocco - The Netherlands -
Singapore - Spain - Sweden - Switzerland - Taiwan - Thailand - United Kingdom - U.S.A