

8-Input Data Selector/ Multiplexer With Data and Address Latches and 3-State Outputs

High-Performance Silicon-Gate CMOS

The MC54/74HC354 is identical in pinout to the LS354. The device inputs are compatible with Standard CMOS outputs; with pullup resistors, they are compatible with LSTTL outputs.

The HC354 selects one of eight latched binary Data Inputs, as determined by the Address Inputs. The information at the Data Inputs is stored in the transparent 8-bit Data Latch when the Data-Latch Enable pin is held high. The Address information may be stored in the transparent Address Latch, which is enabled by the active-high Address-Enable pin.

The device outputs are placed in high-impedance states when Output Enable 1 is high, Output Enable 2 is high, or Output Enable 3 is low.

The HC354 has a clocked Data Latch that is not transparent.

- Output Drive Capability: 15 LSTTL Loads
- Outputs Directly Interface to CMOS, NMOS and TTL
- Operating Voltage Range: 2 to 6V
- Low Input Current: 1µA
- High Noise Immunity Characteristic of CMOS Devices
- In Compliance With the JEDEC Standard No. 7A Requirements
- Chip Complexity: 326 FETs or 81.5 Equivalent Gates

LOGIC DIAGRAM

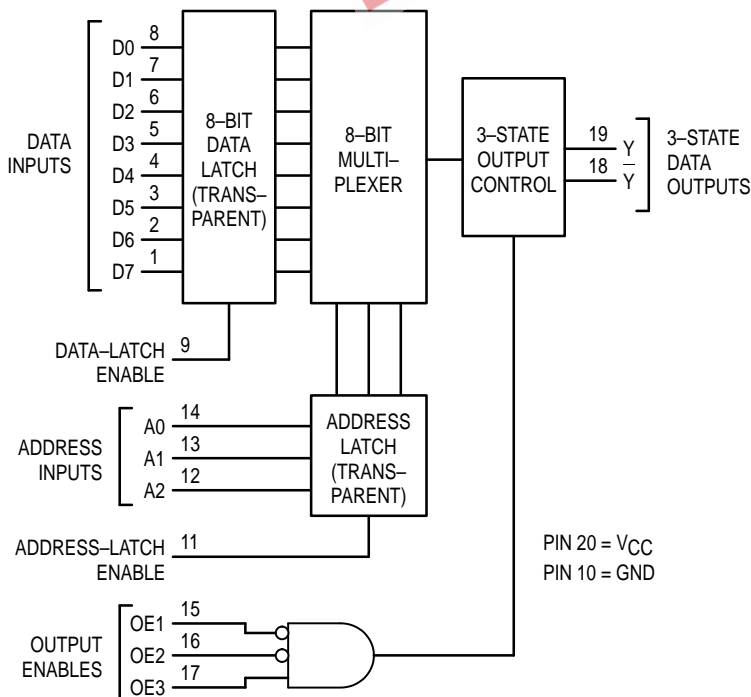

MC54/74HC354

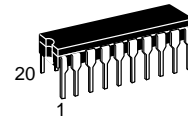

J SUFFIX
CERAMIC PACKAGE
CASE 732-03

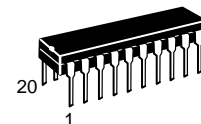

N SUFFIX
PLASTIC PACKAGE
CASE 738-03



DW SUFFIX
SOIC PACKAGE
CASE 751D-04

ORDERING INFORMATION

MC54HCXXXJ	Ceramic
MC74HCXXXN	Plastic
MC74HCXXXDW	SOIC

Pinout: 20-Lead Package (Top View)

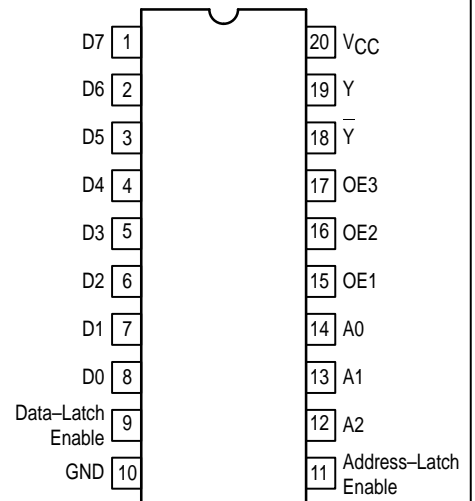

MC54/74HC354

MAXIMUM RATINGS*

Symbol	Parameter	Value	Unit
V _{CC}	DC Supply Voltage (Referenced to GND)	- 0.5 to + 7.0	V
V _{in}	DC Input Voltage (Referenced to GND)	- 1.5 to V _{CC} + 1.5	V
V _{out}	DC Output Voltage (Referenced to GND)	- 0.5 to V _{CC} + 0.5	V
I _{in}	DC Input Current, per Pin	± 20	mA
I _{out}	DC Output Current, per Pin	± 35	mA
I _{CC}	DC Supply Current, V _{CC} and GND Pins	± 75	mA
P _D	Power Dissipation in Still Air, Plastic or Ceramic DIP† SOIC Package†	750 500	mW
T _{stg}	Storage Temperature Range	- 65 to + 150	°C
T _L	Lead Temperature, 1 mm from Case for 10 Seconds Plastic DIP or SOIC Package Ceramic DIP	260 300	°C

This device contains protection circuitry to guard against damage due to high static voltages or electric fields. However, precautions must be taken to avoid applications of any voltage higher than maximum rated voltages to this high-impedance circuit. For proper operation, V_{in} and V_{out} should be constrained to the range GND ≤ (V_{in} or V_{out}) ≤ V_{CC}. Unused inputs must always be tied to an appropriate logic voltage level (e.g., either GND or V_{CC}). Unused outputs must be left open.

* Maximum Ratings are those values beyond which damage to the device may occur. Functional operation should be restricted to the Recommended Operating Conditions.

† Derating — Plastic DIP: - 10 mW/°C from 65° to 125°C
Ceramic DIP: - 10 mW/°C from 100° to 125°C
SOIC Package: - 7 mW/°C from 65° to 125°C

For high frequency or heavy load considerations, see Chapter 2 of the Motorola High-Speed CMOS Data Book (DL129/D).

RECOMMENDED OPERATING CONDITIONS

Symbol	Parameter	Min	Max	Unit
V _{CC}	DC Supply Voltage (Referenced to GND)	2.0	6.0	V
V _{in} , V _{out}	DC Input Voltage, Output Voltage (Referenced to GND)	0	V _{CC}	V
T _A	Operating Temperature Range, All Package Types	- 55	+ 125	°C
t _r , t _f	Input Rise/Fall Time (Figure 1)	V _{CC} = 2.0 V V _{CC} = 4.5 V V _{CC} = 6.0 V	0 1000 500 400	ns

DC CHARACTERISTICS (Voltages Referenced to GND)

Symbol	Parameter	Condition	V _{CC} V	Guaranteed Limit			Unit
				-55 to 25°C	≤85°C	≤125°C	
V _{IH}	Minimum High-Level Input Voltage	V _{out} = 0.1V or V _{CC} - 0.1V I _{out} ≤ 20μA	2.0	1.50	1.50	1.50	V
			4.5	3.15	3.15	3.15	
			6.0	4.20	4.20	4.20	
V _{IL}	Maximum Low-Level Input Voltage	V _{out} = 0.1V or V _{CC} - 0.1V I _{out} ≤ 20μA	2.0	0.3	0.3	0.3	V
			4.5	0.9	0.9	0.9	
			6.0	1.2	1.2	1.2	
V _{OH}	Minimum High-Level Output Voltage	V _{in} = V _{IH} or V _{IL} I _{out} ≤ 20μA	2.0	1.9	1.9	1.9	V
			4.5	4.4	4.4	4.4	
		V _{in} = V _{IH} or V _{IL} I _{out} ≤ 6.0mA I _{out} ≤ 7.8mA	6.0	5.9	5.9	5.9	
			4.5	3.98	3.84	3.70	
6.0	5.48	5.34	5.20				
V _{OL}	Maximum Low-Level Output Voltage	V _{in} = V _{IH} or V _{IL} I _{out} ≤ 20μA	2.0	0.1	0.1	0.1	V
			4.5	0.1	0.1	0.1	
		V _{in} = V _{IH} or V _{IL} I _{out} ≤ 6.0mA I _{out} ≤ 7.8mA	6.0	0.1	0.1	0.1	
			4.5	0.26	0.33	0.40	
6.0	0.26	0.33	0.40				
I _{in}	Maximum Input Leakage Current	V _{in} = V _{CC} or GND	6.0	±0.1	±1.0	±1.0	μA

DC CHARACTERISTICS (Voltages Referenced to GND)

Symbol	Parameter	Condition	V _{CC} V	Guaranteed Limit			Unit
				-55 to 25°C	≤85°C	≤125°C	
I _{OZ}	Maximum Three-State Leakage Current	Output in High-Impedance State V _{in} = V _{IL} or V _{IH} V _{out} = V _{CC} or GND	6.0	±0.5	±5.0	±10.0	μA
I _{CC}	Maximum Quiescent Supply Current (per Package)	V _{in} = V _{CC} or GND I _{out} = 0μA	6.0	8	80	160	μA

NOTE: Information on typical parametric values can be found in Chapter 2 of the Motorola High-Speed CMOS Data Book (DL129/D).

AC CHARACTERISTICS (C_L = 50 pF, Input t_r = t_f = 6 ns)

Symbol	Parameter	V _{CC} V	Guaranteed Limit			Unit
			-55 to 25°C	≤85°C	≤125°C	
t _{PLH} , t _{PHL}	Maximum Propagation Delay, D0–D7 to Y or Y (Figures 2 and 6)	2.0	210	265	315	ns
		4.5	42	53	63	
		6.0	36	45	54	
t _{PLH} , t _{PHL}	Maximum Propagation Delay, Data–Latch Enable to Y or Y (Figures 3 and 6)	2.0	260	325	390	ns
		4.5	52	65	78	
		6.0	44	55	66	
t _{PLH} , t _{PHL}	Maximum Propagation Delay, A0–A2 to Y or Y (Figures 2 and 6)	2.0	270	340	405	ns
		4.5	54	68	81	
		6.0	46	58	69	
t _{PLH} , t _{PHL}	Maximum Propagation Delay, Address–Latch Enable to Y or Y (Figures 3 and 6)	2.0	270	340	405	ns
		4.5	54	68	81	
		6.0	46	58	69	
t _{PLZ} , t _{PHZ}	Maximum Propagation Delay, OE1–OE3 to Y or Y (Figures 4 and 7)	2.0	160	200	240	ns
		4.5	32	40	48	
		6.0	27	34	41	
t _{PZL} , t _{PZH}	Maximum Propagation Delay, OE1–OE3 to Y or Y (Figures 4 and 7)	2.0	125	155	190	ns
		4.5	25	31	38	
		6.0	21	26	32	
t _{TLH} , t _{THL}	Maximum Output Transition Time, Any Output (Figures 1 and 6)	2.0	60	75	90	ns
		4.5	12	15	18	
		6.0	10	13	15	
C _{in}	Maximum Input Capacitance		10	10	10	pF
C _{out}	Maximum Three-State Output Capacitance (Output in High Impedance State)		15	15	15	pF

NOTE: For propagation delays with loads other than 50 pF, and information on typical parametric values, see Chapter 2 of the Motorola High-Speed CMOS Data Book (DL129/D).

CPD	Power Dissipation Capacitance (Per Package)*	Typical @ 25°C, V _{CC} = 5.0 V	
		48	pF

* Used to determine the no-load dynamic power consumption: $P_D = CPD V_{CC}^2 f + I_{CC} V_{CC}$. For load considerations, see Chapter 2 of the Motorola High-Speed CMOS Data Book (DL129/D).

PIN DESCRIPTIONS

D0–D7 (Pins 8–1) DATA INPUTS

These eight data bits are stored in a transparent latch when the Data–Latch Enable pin is active (high). Once enabled, changing inputs will not change the contents of the latch.

A0, A1, A2 (Pins 14,13,12) ADDRESS INPUTS

Selects which data bit stored in the Data Latch is routed to the outputs Y and \bar{Y} .

DATA–LATCH ENABLE (Pin 9)

The latch is transparent to D0–D7 when enable is inactive (low). The Data–Latch contents are unaffected when enable is held active (high).

ADDRESS–LATCH ENABLE (Pin 11)

The latch is transparent to A0, A1 and A2 when enable is inactive (low). The Address–Latch contents are unaffected when enable is held active (high).

OE1, OE2, OE3 (Pins 15,16,17) OUTPUT ENABLES

Any of the output enable pins inactive (OE1=High or OE2=High or OE3=Low) causes the outputs (Y and \bar{Y}) to be in high–impedance states.

Y, \bar{Y} (Pins 19,18)

These 3–state outputs (when not 3–stated) represent the data bit in the Data Latch selected by the Address Latch.

TIMING REQUIREMENTS (Input $t_r = t_f = 6$ ns)

Symbol	Parameter	V _{CC} V	Guaranteed Limit			Unit
			–55 to 25°C	≤85°C	≤125°C	
t_{su}	Minimum Setup Time, D0–D7 to Data–Latch Enable (Figure 5)	2.0	50	65	75	ns
		4.5	10	13	15	
		6.0	9	11	13	
t_{su}	Minimum Setup Time, A0–A2 to Address–Latch Enable (Figure 5)	2.0	50	65	75	ns
		4.5	10	13	15	
		6.0	9	11	13	
t_h	Minimum Hold Time, Data–Latch Enable to D0–D7 (Figure 5)	2.0	5	5	5	ns
		4.5	5	5	5	
		6.0	5	5	5	
t_h	Minimum Hold Time, Address–Latch Enable to A0–A2 (Figure 5)	2.0	5	5	5	ns
		4.5	5	5	5	
		6.0	5	5	5	
t_w	Minimum Pulse Width, Data–Latch Enable (Figure 3)	2.0	80	100	120	ns
		4.5	16	20	24	
		6.0	14	17	20	
t_w	Minimum Pulse Width, Address–Latch Enable (Figure 3)	2.0	80	100	120	ns
		4.5	16	20	24	
		6.0	14	17	20	
t_r, t_f	Maximum Input Rise and Fall Times (Figure 1)	2.0	1000	1000	1000	ns
		4.5	500	500	500	
		6.0	400	400	400	

NOTE: Information on typical parametric values can be found in Chapter 2 of the Motorola High–Speed CMOS Data Book (DL129/D).

FUNCTION TABLE

Address Latch Contents #			Inputs				Outputs		Description
A2	A1	A0	Data-Latch Enable	OE1	OE2	OE3	Y	\bar{Y}	
X	X	X	X	H	X	X	Z	Z	Outputs in High-Impedance States
X	X	X	X	X	H	X	Z	Z	
X	X	X	X	X	X	L	Z	Z	
L	L	L	↓	↓	↓	↓	D0	$\bar{D0}$	Data-Latch is Transparent
L	L	H					D1	$\bar{D1}$	
L	H	L					D2	$\bar{D2}$	
L	H	H					D3	$\bar{D3}$	
H	L	L					D4	$\bar{D4}$	
H	L	H					D5	$\bar{D5}$	
H	H	L					D6	$\bar{D6}$	
H	H	H					D7	$\bar{D7}$	
L	L	L	↓	↓	↓	↓	D0 _n	$\bar{D0}_n$	New Data is Stored in Data-Latch and is Not Alterable
L	L	H					D1 _n	$\bar{D1}_n$	
L	H	L					D2 _n	$\bar{D2}_n$	
L	H	H					D3 _n	$\bar{D3}_n$	
H	L	L					D4 _n	$\bar{D4}_n$	
H	L	H					D5 _n	$\bar{D5}_n$	
H	H	L					D6 _n	$\bar{D6}_n$	
H	H	H					D7 _n	$\bar{D7}_n$	

Represents bits in Address-Latch. See Address-Latch Enable pin description.
 X = Don't Care; Z = High Impedance; D0-D7 = the data at inputs D0 through D7; D0_n-D7_n = the data present at inputs D0 through D7 when the Data-Latch Enable pin was taken high.

SWITCHING WAVEFORMS

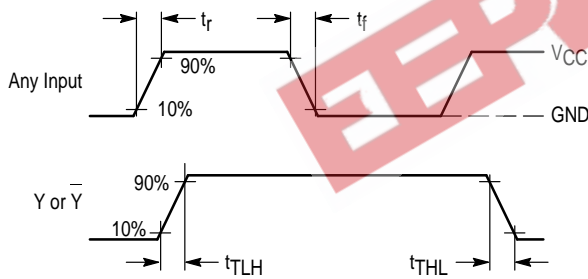

Figure 1.

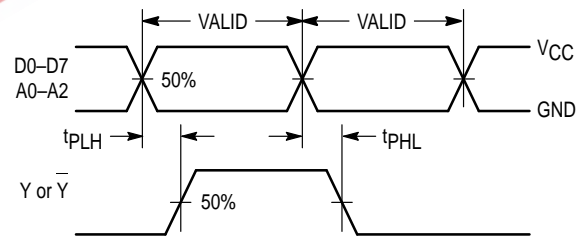

Figure 2.

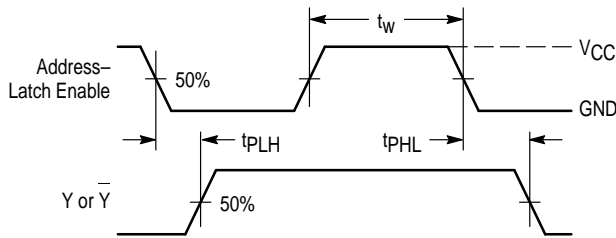

Figure 3.

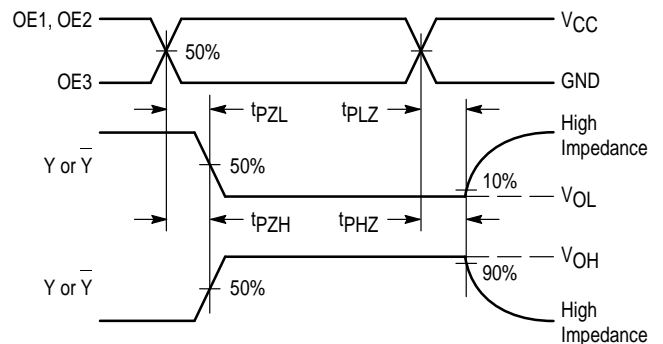

Figure 4.

MC54/74HC354

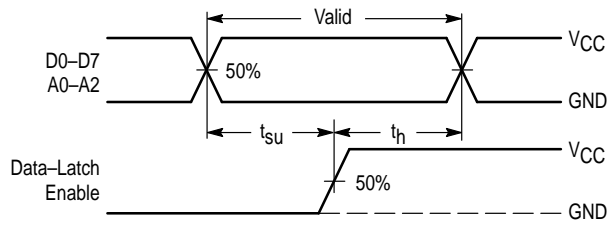
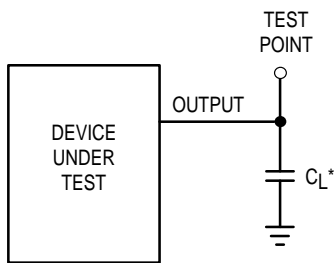

Figure 5.

TEST CIRCUITS



*Includes all probe and jig capacitance

Figure 6.

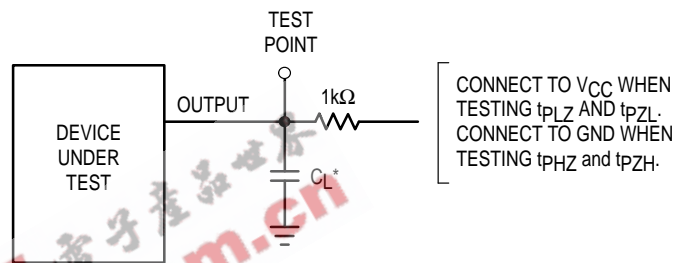

CONNECT TO V_{CC} WHEN TESTING t_{pLZ} AND t_{pZL} .
CONNECT TO GND WHEN TESTING t_{pHZ} and t_{pZH} .

*Includes all probe and jig capacitance

Figure 7.

OUTLINE DIMENSIONS

J SUFFIX
CERAMIC PACKAGE
CASE 732-03
ISSUE E

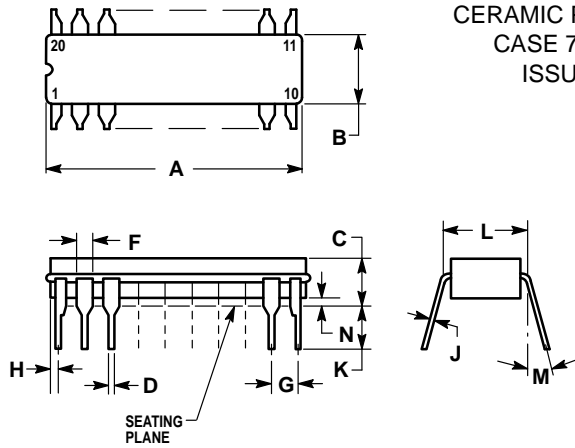

- NOTES:
- LEADS WITHIN 0.25 (0.010) DIAMETER, TRUE POSITION AT SEATING PLANE, AT MAXIMUM MATERIAL CONDITION.
 - DIMENSION L TO CENTER OF LEADS WHEN FORMED PARALLEL.
 - DIMENSIONS A AND B INCLUDE MENISCUS.

DIM	MILLIMETERS		INCHES	
	MIN	MAX	MIN	MAX
A	23.88	25.15	0.940	0.990
B	6.60	7.49	0.260	0.295
C	3.81	5.08	0.150	0.200
D	0.38	0.56	0.015	0.022
F	1.40	1.65	0.055	0.065
G	2.54 BSC		0.100 BSC	
H	0.51	1.27	0.020	0.050
J	0.20	0.30	0.008	0.012
K	3.18	4.06	0.125	0.160
L	7.62 BSC		0.300 BSC	
M	0°	15°	0°	15°
N	0.25	1.02	0.010	0.040

N SUFFIX
PLASTIC PACKAGE
CASE 738-03
ISSUE E

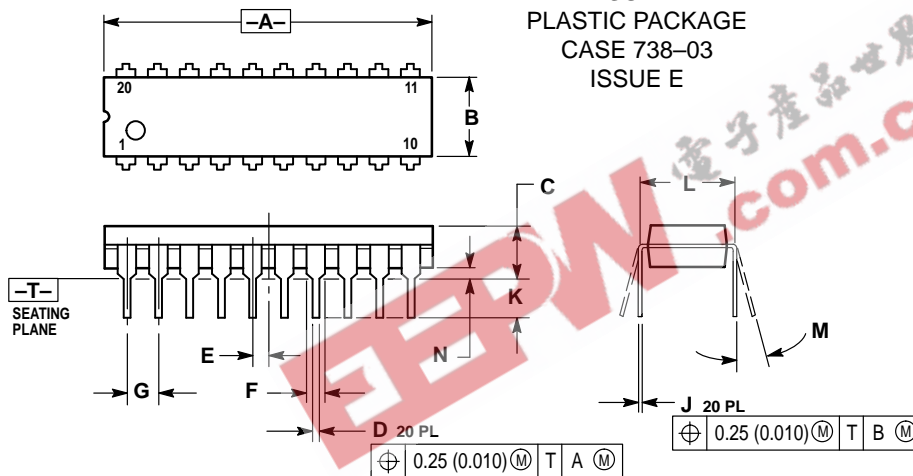

- NOTES:
- DIMENSIONING AND TOLERANCING PER ANSI Y14.5M, 1982.
 - CONTROLLING DIMENSION: INCH.
 - DIMENSION L TO CENTER OF LEAD WHEN FORMED PARALLEL.
 - DIMENSION B DOES NOT INCLUDE MOLD FLASH.

DIM	INCHES		MILLIMETERS	
	MIN	MAX	MIN	MAX
A	1.010	1.070	25.66	27.17
B	0.240	0.260	6.10	6.60
C	0.150	0.180	3.81	4.57
D	0.015	0.022	0.39	0.55
E	0.050 BSC		1.27 BSC	
F	0.050	0.070	1.27	1.77
G	0.100 BSC		2.54 BSC	
J	0.008	0.015	0.21	0.38
K	0.110	0.140	2.80	3.55
L	0.300 BSC		7.62 BSC	
M	0°	15°	0°	15°
N	0.020	0.040	0.51	1.01

DW SUFFIX
PLASTIC SOIC PACKAGE
CASE 751D-04
ISSUE E

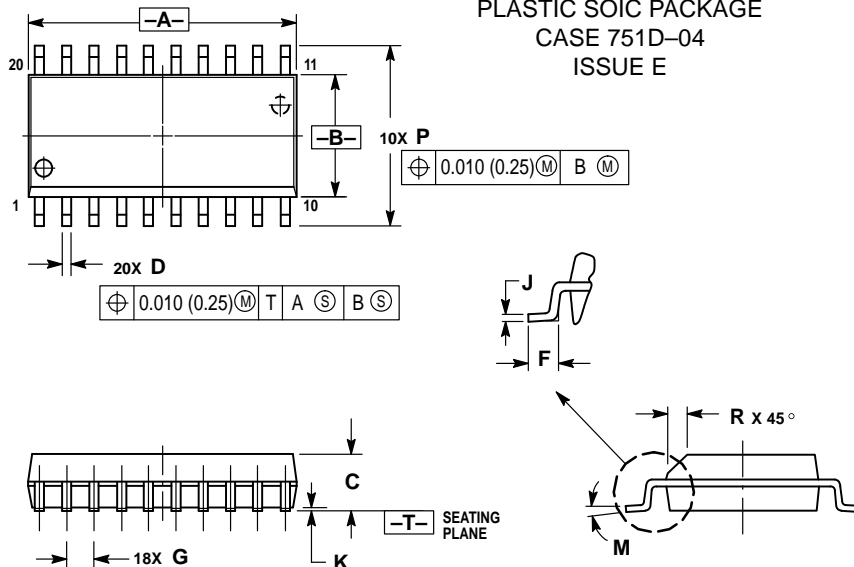

- NOTES:
- DIMENSIONING AND TOLERANCING PER ANSI Y14.5M, 1982.
 - CONTROLLING DIMENSION: MILLIMETER.
 - DIMENSIONS A AND B DO NOT INCLUDE MOLD PROTRUSION.
 - MAXIMUM MOLD PROTRUSION 0.150 (0.006) PER SIDE.
 - DIMENSION D DOES NOT INCLUDE DAMBAR PROTRUSION. ALLOWABLE DAMBAR PROTRUSION SHALL BE 0.13 (0.005) TOTAL IN EXCESS OF D DIMENSION AT MAXIMUM MATERIAL CONDITION.

DIM	MILLIMETERS		INCHES	
	MIN	MAX	MIN	MAX
A	12.65	12.95	0.499	0.510
B	7.40	7.60	0.292	0.299
C	2.35	2.65	0.093	0.104
D	0.35	0.49	0.014	0.019
F	0.50	0.90	0.020	0.035
G	1.27 BSC		0.050 BSC	
J	0.25	0.32	0.010	0.012
K	0.10	0.25	0.004	0.009
M	0°	7°	0°	7°
P	10.05	10.55	0.395	0.415
R	0.25	0.75	0.010	0.029

EEPW 电子产品世界
 .com.cn

Motorola reserves the right to make changes without further notice to any products herein. Motorola makes no warranty, representation or guarantee regarding the suitability of its products for any particular purpose, nor does Motorola assume any liability arising out of the application or use of any product or circuit, and specifically disclaims any and all liability, including without limitation consequential or incidental damages. "Typical" parameters can and do vary in different applications. All operating parameters, including "Typicals" must be validated for each customer application by customer's technical experts. Motorola does not convey any license under its patent rights nor the rights of others. Motorola products are not designed, intended, or authorized for use as components in systems intended for surgical implant into the body, or other applications intended to support or sustain life, or for any other application in which the failure of the Motorola product could create a situation where personal injury or death may occur. Should Buyer purchase or use Motorola products for any such unintended or unauthorized application, Buyer shall indemnify and hold Motorola and its officers, employees, subsidiaries, affiliates, and distributors harmless against all claims, costs, damages, and expenses, and reasonable attorney fees arising out of, directly or indirectly, any claim of personal injury or death associated with such unintended or unauthorized use, even if such claim alleges that Motorola was negligent regarding the design or manufacture of the part. Motorola and  are registered trademarks of Motorola, Inc. Motorola, Inc. is an Equal Opportunity/Affirmative Action Employer.

How to reach us:

USA/EUROPE: Motorola Literature Distribution;
 P.O. Box 20912; Phoenix, Arizona 85036. 1-800-441-2447

JAPAN: Nippon Motorola Ltd.; Tatsumi-SPD-JLDC, Toshikatsu Otsuki,
 6F Seibu-Butsuryu-Center, 3-14-2 Tatsumi Koto-Ku, Tokyo 135, Japan. 03-3521-8315

MFAX: RMFAX0@email.sps.mot.com -TOUCHTONE (602) 244-6609
INTERNET: <http://Design-NET.com>

HONG KONG: Motorola Semiconductors H.K. Ltd.; 8B Tai Ping Industrial Park,
 51 Ting Kok Road, Tai Po, N.T., Hong Kong. 852-26629298



◇ CODELINE

MC54/74HC354/D

