

OM7642SM
OM7643SM

OM7644SM

SURFACE MOUNT NEGATIVE VOLTAGE REGULATOR, 3-TERMINAL, FIXED VOLTAGE

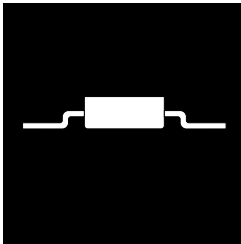

**Isolated Hermetic Surface Mount Package
1.5 Amp, -5V, -12V, -15V Negative Voltage
Regulators**

FEATURES

- Small Hermetic Surface Mount Package
- Chip Isolated From Package
- Output Voltages: -5V, -12V, -15V
- Output Voltages Set Internally To $\pm 1\%$
- Built-In Thermal Overload Protection
- Short Circuit Current Limiting
- Product Is Available Hi-Rel Screened

DESCRIPTION

These three terminal negative regulators are supplied in a hermetically sealed surface mount package. All protective features are designed into the circuit including thermal shutdown, current limiting and safe-area control. With heat sinking, they can deliver over 1.5 amps of output current. These units feature internally trimmed output voltages to $\pm 1\%$ of nominal output voltage. Standard voltages are -5V, -12V, and -15V. These units are ideally suited for Military applications where a hermetically sealed surface mount package is required.

ABSOLUTE MAXIMUM RATINGS

Input to Output Voltage Differential.....-35V
Operating Junction Temperature Range..... - 55°C to + 150°C
Storage Temperature Range - 55°C to + 150°C

Typical Power/Thermal Characteristics:

Rated Power @ 25°C

T_C 17.5W
 T_A 3W

Thermal Resistance:

θ_{JC} 4.2°C/W
 θ_{JA} 42°C/W
Lead Temperature at Case (5 sec)..... 225°C

3.5

OM7642SM - OM7644SM

ELECTRICAL CHARACTERISTICS -5 Volt $V_{IN} = -10V, I_O = 500mA, -55^{\circ}C \leq T_A \leq 125^{\circ}C$ (unless otherwise specified)

Parameter	Symbol	Test Conditions	Min.	Max.	Unit
Output Voltage	V_{OUT}	$T_A = 25^{\circ}C$	-4.95	-5.05	V
		$V_{IN} = -7.5V$ to $-20V$	• -4.85	-5.15	V
Line Regulation (Note 1)	V_{RLINE}	$V_{IN} = -7.5V$ to $-20V$	•	12	mV
			•	25	mV
		$V_{IN} = -8.0V$ to $-12V$	•	5	mV
Load Regulation (Note 1)	V_{RLOAD}	$I_O = 5mA$ to 1.5 Amp	•	20	mV
			•	25	mV
		$I_O = 250mA$ to 750 mA	•	15	mV
Standby Current Drain	I_{SCD}		•	30	mV
			•	2.5	mA
Standby Current Drain Change With Line	ΔI_{SCD} (Line)	$V_{IN} = -7.0V$ to $-20V$	•	3.0	mA
Standby Current Drain Change With Load	ΔI_{SCD} (Load)	$I_O = 5mA$ to 1000mA	•	0.4	mA
Dropout Voltage	V_{DO}	$\Delta V_{OUT} = 100mV, I_O = 1.0A$	•	2.5	V
Peak Output Current	$I_{O(pk)}$	$T_A = 25^{\circ}C$	1.5	3.3	A
Short Circuit Current (Note 2)	I_{DS}	$V_{IN} = -35V$	•	1.2	A
			•	2.8	A
Ripple Rejection	ΔV_{IN}	$f = 120 Hz, \Delta V_{IN} = -10V$	•	63	dB
	ΔV_{OUT}	(Note 3)	•	60	dB
Output Noise Voltage (Note 3)	N_O	$T_A = 25^{\circ}C, f = 10 Hz$ to 100KHz		40	$\mu V/V$ RMS
Long Term Stability (Note 3)	$\frac{\Delta V_{OUT}}{\Delta t}$	$T_A = 25^{\circ}C, t = 1000 hrs.$		75	mV

ELECTRICAL CHARACTERISTICS -12 Volt $V_{IN} = -19V, I_O = 500mA, -55^{\circ}C \leq T_A \leq 125^{\circ}C$ (unless otherwise specified)

Parameter	Symbol	Test Conditions	Min.	Max.	Unit
Output Voltage	V_{OUT}	$T_A = 25^{\circ}C$	-11.88	-12.12	V
		$V_{IN} = -14.5V$ to $-27V$	• -11.64	-12.36	V
Line Regulation (Note 1)	V_{RLINE}	$V_{IN} = -14.5V$ to $-27V$	•	20	mV
			•	50	mV
		$V_{IN} = -16V$ to $-22V$	•	10	mV
Load Regulation (Note 1)	V_{RLOAD}	$I_O = 5mA$ to 1.5 Amp	•	30	mV
			•	60	mV
		$I_O = 250mA$ to 750 mA	•	16	mV
Standby Current Drain	I_{SCD}		•	30	mV
			•	3.5	mA
Standby Current Drain Change With Line	ΔI_{SCD} (Line)	$V_{IN} = -14.5V$ to $-27V$	•	4.0	mA
Standby Current Drain Change With Load	ΔI_{SCD} (Load)	$I_O = 5mA$ to 1000mA	•	0.8	mA
Dropout Voltage	V_{DO}	$\Delta V_{OUT} = 100mV, I_O = 1.0A$	•	1.8	V
Peak Output Current	$I_{O(pk)}$	$T_A = 25^{\circ}C, I_O = 5mA$ to 1A	1.5	3.3	A
Short Circuit Current (Note 2)	I_{DS}	$V_{IN} = -35V$	•	1.2	A
			•	2.8	A
Ripple Rejection	ΔV_{IN}	$f = 120 Hz, \Delta V_{IN} = -10V$	•	56	dB
	ΔV_{OUT}	(Note 3)	•	53	dB
Output Noise Voltage (Note 3)	N_O	$T_A = 25^{\circ}C, f = 10 Hz$ to 100KHz		40	$\mu V/V$ RMS
Long Term Stability (Note 3)	$\frac{\Delta V_{OUT}}{\Delta t}$	$T_A = 25^{\circ}C, t = 1000 hrs.$		120	mV

Notes:

- Load and Line Regulation are specified at a constant junction temperature. Pulse testing with low duty cycle is used. Changes in output voltage due to heating effects must be taken into account separately.
 - Short Circuit protection is only assured up to $V_{IN} = -35V$.
 - If not tested, shall be guaranteed to the specified limits.
- The • denotes the specifications which apply over the full operating temperature range.

ELECTRICAL CHARACTERISTICS -15 Volt $V_{IN} = -23V, I_o = 500mA, -55^{\circ}C \leq T_A \leq 125^{\circ}C$ (unless otherwise specified)

Parameter	Symbol	Test Conditions	Min.	Max.	Unit
Output Voltage	V_{OUT}	$T_A = 25^{\circ}C$	-14.85	-15.15	V
		$V_{IN} = -17.5V$ to $-30V$	• -14.55	-15.45	V
Line Regulation (Note 1)	V_{RLINE}	$V_{IN} = -17.5V$ to $-30V$	•	25	mV
		$V_{IN} = -20V$ to $-26V$	•	50	mV
			•	15	mV
Load Regulation (Note 1)	V_{RLOAD}	$I_o = 5mA$ to 1.5 Amp	•	35	mV
		$I_o = 250mA$ to 750 mA	•	75	mV
			•	21	mV
Standby Current Drain	I_{SCD}		•	6.0	mA
			•	6.5	mA
Standby Current Drain Change With Line	ΔI_{SCD} (Line)	$V_{IN} = -17.5V$ to $-30V$	•	0.8	mA
Standby Current Drain Change With Load	ΔI_{SCD} (Load)	$I_o = 5mA$ to 1000mA	•	0.5	mA
Dropout Voltage	V_{DO}	$\Delta V_{OUT} = 100mV, I_o = 1.0A$	•	2.5	V
Peak Output Current	$I_{O(pk)}$	$T_A = 25^{\circ}C$	1.5	3.3	A
Short Circuit Current (Note 2)	I_{DS}	$V_{IN} = -35V$	•	1.2	A
			•	2.8	A
Ripple Rejection	$\frac{\Delta V_{IN}}{\Delta V_{OUT}}$	$f = 120 Hz, \Delta V_{IN} = -10V$	•	53	dB
	$\frac{\Delta V_{OUT}}{\Delta V_{IN}}$	(Note 3)	•	50	dB
Output Noise Voltage (Note 3)	N_O	$T_A = 25^{\circ}C, f = 10 Hz$ to 100KHz		40	$\mu V/V$ RMS
Long Term Stability (Note 3)	$\frac{\Delta V_{OUT}}{\Delta t}$	$T_A = 25^{\circ}C, t = 1000 hrs.$		150	mV

Notes:

1. Load and Line Regulation are specified at a constant junction temperature. Pulse testing with low duty cycle is used. Changes in output voltage due to heating effects must be taken into account separately.
2. Short Circuit protection is only assured up to $V_{IN} = -35V$.
3. If not tested, shall be guaranteed to the specified limits.
The • denotes the specifications which apply over the full operating temperature range.

TYPICAL PERFORMANCE CHARACTERISTICS

PEAK OUTPUT CURRENT

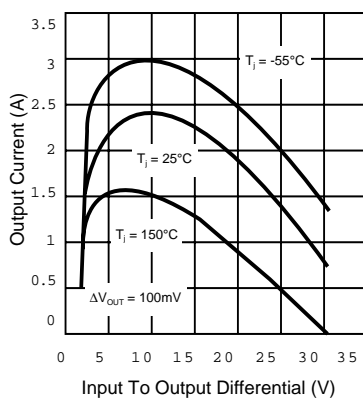

DROPOUT VOLTAGE

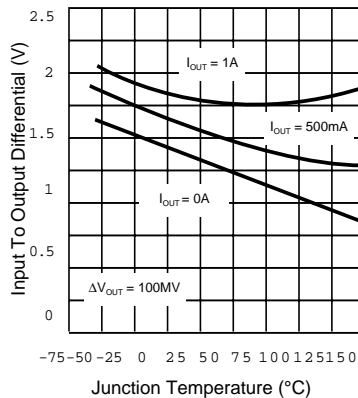

RIPPLE REJECTION

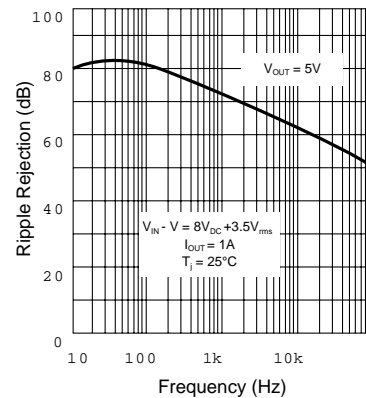

3.5



OM7642SM - OM7644SM

TYPICAL PERFORMANCE CHARACTERISTICS

Input bypass capacitors are recommended for stable operation of the OM7642SM series of regulators over the input voltage and output current ranges. Output bypass capacitors will improve the transient response of the regulator.

The bypass capacitors, (2.2μF on the input, 1μF on the output) should be ceramic or solid tantalum which have good high frequency characteristics. If aluminum electrolytics are used, their values should be 10μF or larger. The bypass capacitors should be mounted with the shortest leads and, if possible, directly across the regulator terminals.

FIXED OUTPUT REGULATOR

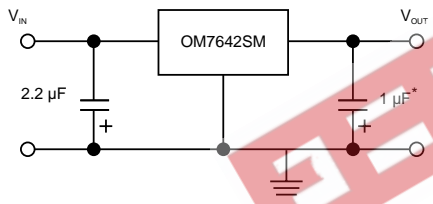

BASIC CURRENT REGULATOR

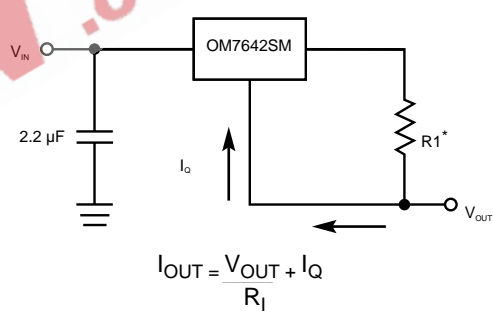

MECHANICAL OUTLINE

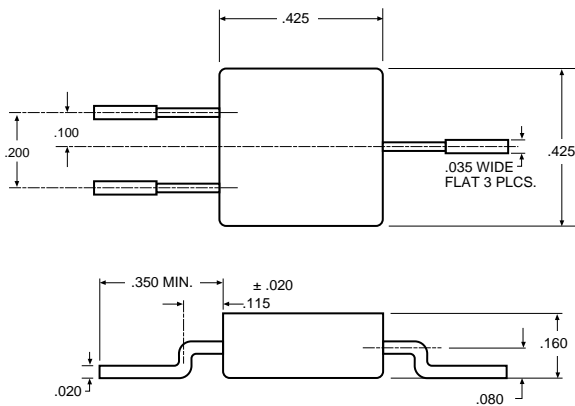

PIN CONNECTION

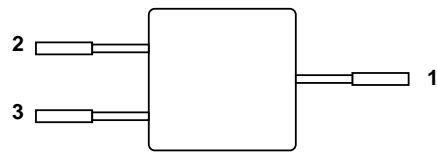

- Pin 1: V_{IN}
- Pin 2: Adjust
- Pin 3: V_{OUT}
- Case: Isolated