

SN54ABT16652, SN74ABT16652 16-BIT BUS TRANSCEIVERS AND REGISTERS WITH 3-STATE OUTPUTS

SCBS215B – FEBRUARY 1991 – REVISED JANUARY 1997

- Members of the Texas Instruments *Widebus™* Family
- State-of-the-Art *EPIC-II B™* BiCMOS Design Significantly Reduces Power Dissipation
- Latch-Up Performance Exceeds 500 mA Per JEDEC Standard JESD-17
- Typical V_{OLP} (Output Ground Bounce) < 1 V at $V_{CC} = 5$ V, $T_A = 25^\circ\text{C}$
- Distributed V_{CC} and GND Pin Configuration Minimizes High-Speed Switching Noise
- Flow-Through Architecture Optimizes PCB Layout
- High-Drive Outputs ($-32\text{-mA } I_{OH}$, $64\text{-mA } I_{OL}$)
- Package Options Include Plastic 300-mil Shrink Small-Outline (DL) Package and 380-mil Fine-Pitch Ceramic Flat (WD) Package Using 25-mil Center-to-Center Spacings

description

The 'ABT16652 are 16-bit bus transceivers that consist of D-type flip-flops and control circuitry arranged for multiplexed transmission of data directly from the data bus or from the internal storage registers. These devices can be used as two 8-bit transceivers or one 16-bit transceiver.

Output-enable (OEAB and OEBA) inputs are provided to control the transceiver functions. Select-control (SAB and SBA) inputs are provided to select whether real-time or stored data is transferred. The circuitry used for select control eliminates the typical decoding glitch that occurs in a multiplexer during the transition between stored and real-time data. A low input selects real-time data, and a high input selects stored data. Figure 1 illustrates the four fundamental bus-management functions that can be performed with the 'ABT16652.

Data on the A- or B-data bus, or both, can be stored in the internal D-type flip-flops by low-to-high transitions at the appropriate clock (CLKAB or CLKBA) inputs regardless of the select- or enable-control inputs. When SAB and SBA are in the real-time transfer mode, it is possible to store data without using the internal D-type flip-flops by simultaneously enabling OEAB and OEBA. In this configuration, each output reinforces its input. When all other data sources to the two sets of bus lines are at high impedance, each set of bus lines remains at its last state.

SN54ABT16652 . . . WD PACKAGE
SN74ABT16652 . . . DL PACKAGE
(TOP VIEW)

1OEAB	1	56	1OEBA
1CLKAB	2	55	1CLKBA
1SAB	3	54	1SBA
GND	4	53	GND
1A1	5	52	1B1
1A2	6	51	1B2
V_{CC}	7	50	V_{CC}
1A3	8	49	1B3
1A4	9	48	1B4
1A5	10	47	1B5
GND	11	46	GND
1A6	12	45	1B6
1A7	13	44	1B7
1A8	14	43	1B8
2A1	15	42	2B1
2A2	16	41	2B2
2A3	17	40	2B3
GND	18	39	GND
2A4	19	38	2B4
2A5	20	37	2B5
2A6	21	36	2B6
V_{CC}	22	35	V_{CC}
2A7	23	34	2B7
2A8	24	33	2B8
GND	25	32	GND
2SAB	26	31	2SBA
2CLKAB	27	30	2CLKBA
2OEAB	28	29	2OEBA



Please be aware that an important notice concerning availability, standard warranty, and use in critical applications of Texas Instruments semiconductor products and disclaimers thereto appears at the end of this data sheet.

Widebus and EPIC-II B are trademarks of Texas Instruments Incorporated.

PRODUCTION DATA information is current as of publication date. Products conform to specifications per the terms of Texas Instruments standard warranty. Production processing does not necessarily include testing of all parameters.

 **TEXAS
INSTRUMENTS**

POST OFFICE BOX 655303 • DALLAS, TEXAS 75265

Copyright © 1997, Texas Instruments Incorporated

SN54ABT16652, SN74ABT16652 16-BIT BUS TRANSCEIVERS AND REGISTERS WITH 3-STATE OUTPUTS

SCBS215B – FEBRUARY 1991 – REVISED JANUARY 1997

description (continued)

To ensure the high-impedance state during power up or power down, \overline{OEBA} should be tied to V_{CC} through a pullup resistor; the minimum value of the resistor is determined by the current-sinking capability of the driver (B to A). OEAB should be tied to GND through a pulldown resistor; the minimum value of the resistor is determined by the current-sourcing capability of the driver (A to B).

The SN54ABT16652 is characterized for operation over the full military temperature range of -55°C to 125°C . The SN74ABT16652 is characterized for operation from -40°C to 85°C .

FUNCTION TABLE

INPUTS						DATA I/O [†]		OPERATION OR FUNCTION
OEAB	\overline{OEBA}	CLKAB	CLKBA	SAB	SBA	A1–A8	B1–B8	
L	H	H or L	H or L	X	X	Input	Input	Isolation
L	H	↑	↑	X	X	Input	Input	Store A and B data
X	H	↑	H or L	X	X	Input	Unspecified [‡]	Store A, hold B
H	H	↑	↑	X [‡]	X	Input	Output	Store A in both registers
L	X	H or L	↑	X	X	Unspecified [‡]	Input	Hold A, store B
L	L	↑	↑	X	X [‡]	Output	Input	Store B in both registers
L	L	X	X	X	L	Output	Input	Real-time B data to A bus
L	L	X	H or L	X	H	Output	Input	Stored B data to A bus
H	H	X	X	L	X	Input	Output	Real-time A data to B bus
H	H	H or L	X	H	X	Input	Output	Stored A data to B bus
H	L	H or L	H or L	H	H	Output	Output	Stored A data to B bus and stored B data to A bus

[†] The data-output functions may be enabled or disabled by a variety of level combinations at OEAB or \overline{OEBA} . Data-input functions are always enabled; i.e., data at the bus terminals is stored on every low-to-high transition of the clock inputs.

[‡] Select control = L; clocks can occur simultaneously.

Select control = H; clocks must be staggered to load both registers.

SN54ABT16652, SN74ABT16652
 16-BIT BUS TRANSCEIVERS AND REGISTERS
 WITH 3-STATE OUTPUTS

SCBS215B – FEBRUARY 1991 – REVISED JANUARY 1997

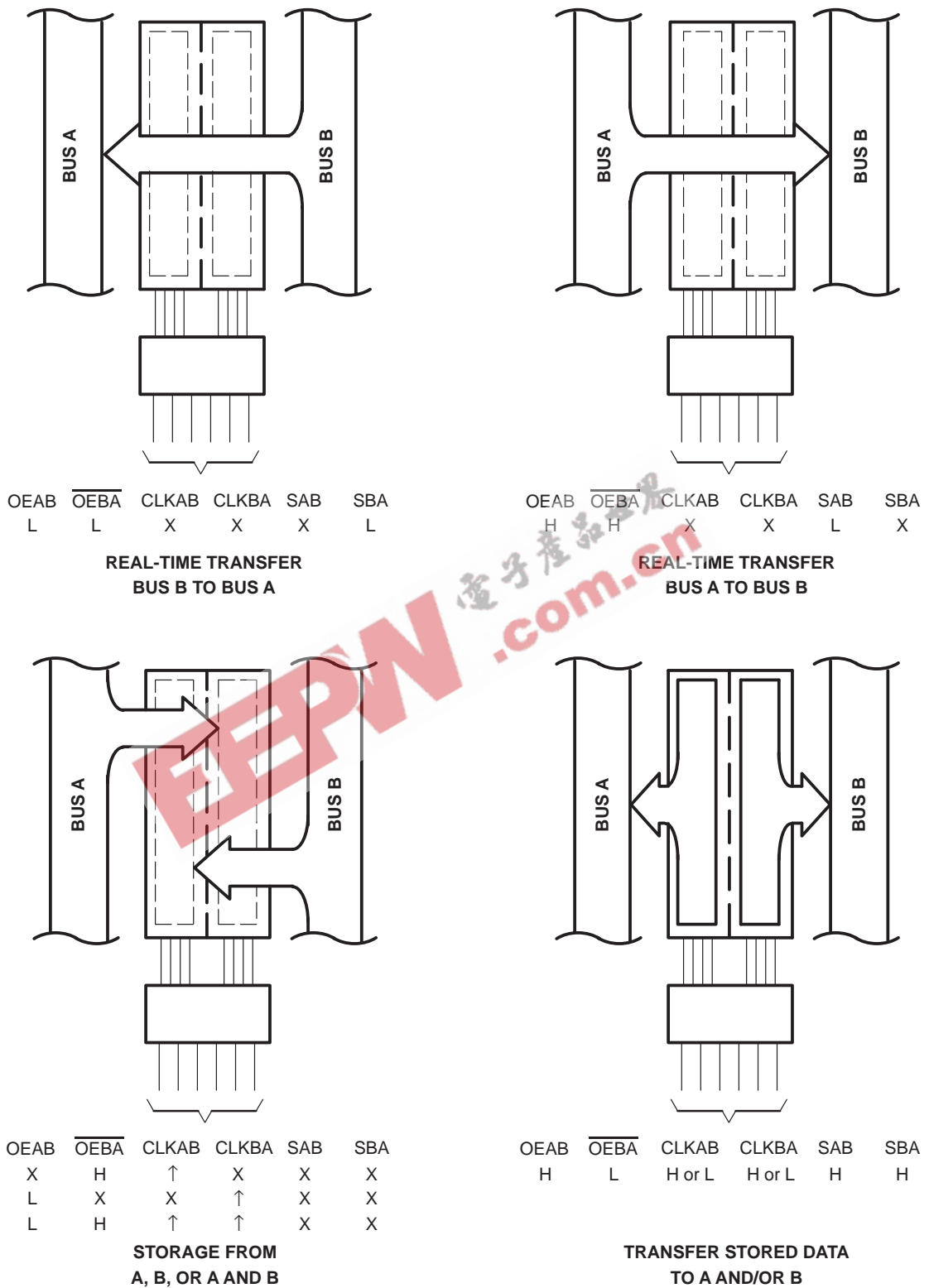
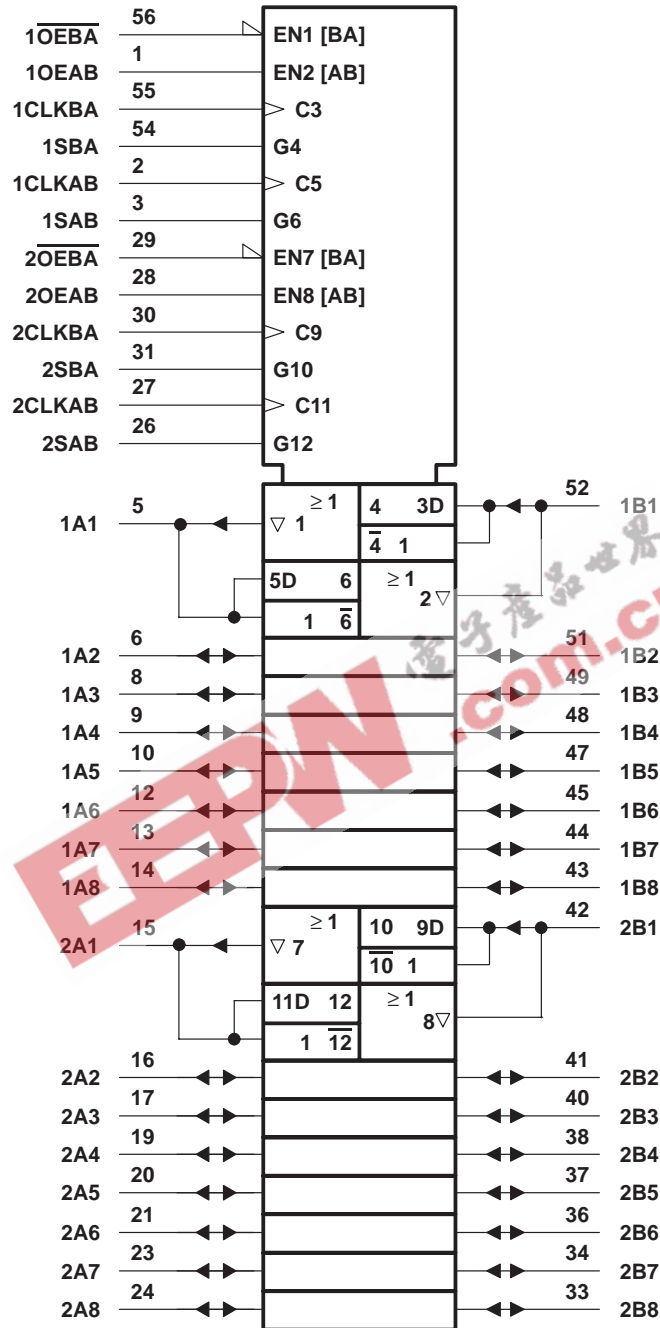

Figure 1. Bus-Management Functions

SN54ABT16652, SN74ABT16652 16-BIT BUS TRANSCEIVERS AND REGISTERS WITH 3-STATE OUTPUTS

SCBS215B – FEBRUARY 1991 – REVISED JANUARY 1997

logic symbol†



† This symbol is in accordance with ANSI/IEEE Std 91-1984 and IEC Publication 617-12.

SN54ABT16652, SN74ABT16652
 16-BIT BUS TRANSCEIVERS AND REGISTERS
 WITH 3-STATE OUTPUTS

SCBS215B - FEBRUARY 1991 - REVISED JANUARY 1997

logic diagram (positive logic)

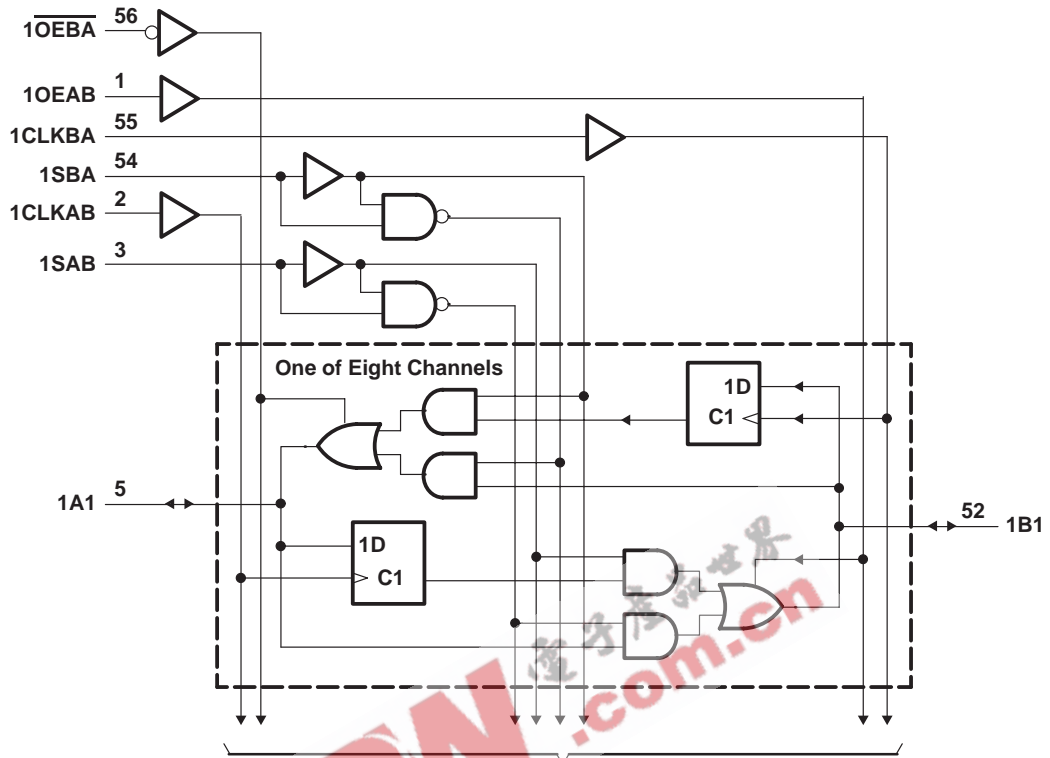

To Seven Other Channels

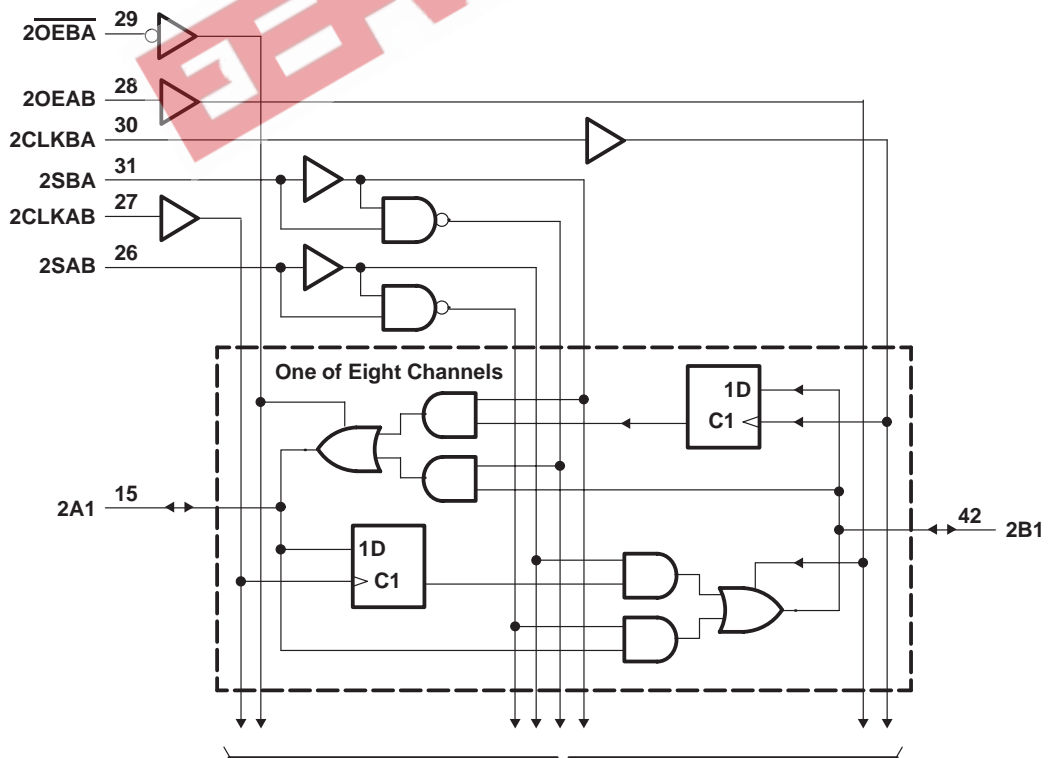

To Seven Other Channels

SN54ABT16652, SN74ABT16652 16-BIT BUS TRANSCEIVERS AND REGISTERS WITH 3-STATE OUTPUTS

SCBS215B – FEBRUARY 1991 – REVISED JANUARY 1997

absolute maximum ratings over operating free-air temperature range (unless otherwise noted)†

Supply voltage range, V_{CC}	–0.5 V to 7 V
Input voltage range, V_I (except I/O ports) (see Note 1)	–0.5 V to 7 V
Voltage range applied to any output in the high or power-off state, V_O	–0.5 V to 5.5 V
Current into any output in the low state, I_O : SN54ABT16652	96 mA
SN74ABT16652	128 mA
Input clamp current, I_{IK} ($V_I < 0$)	–18 mA
Output clamp current, I_{OK} ($V_O < 0$)	–50 mA
Package thermal impedance, θ_{JA} (see Note 2): DL package	74°C/W
Storage temperature range, T_{stg}	–65°C to 150°C

† Stresses beyond those listed under “absolute maximum ratings” may cause permanent damage to the device. These are stress ratings only, and functional operation of the device at these or any other conditions beyond those indicated under “recommended operating conditions” is not implied. Exposure to absolute-maximum-rated conditions for extended periods may affect device reliability.

- NOTES: 1. The input and output negative-voltage ratings may be exceeded if the input and output clamp-current ratings are observed.
2. The package thermal impedance is calculated in accordance with EIA/JEDEC Std JESD51.

recommended operating conditions (see Note 3)

	SN54ABT16652		SN74ABT16652		UNIT
	MIN	MAX	MIN	MAX	
V_{CC} Supply voltage	4.5	5.5	4.5	5.5	V
V_{IH} High-level input voltage	2		2		V
V_{IL} Low-level input voltage		0.8		0.8	V
V_I Input voltage	0	V_{CC}	0	V_{CC}	V
I_{OH} High-level output current		–24		–32	mA
I_{OL} Low-level output current		48		64	mA
$\Delta t/\Delta v$ Input transition rise or fall rate	Outputs enabled		10	10	ns/V
T_A Operating free-air temperature	–55	125	–40	85	°C

NOTE 3: Unused pins (input or I/O) must be held high or low to prevent them from floating.

SN54ABT16652, SN74ABT16652 16-BIT BUS TRANSCEIVERS AND REGISTERS WITH 3-STATE OUTPUTS

SCBS215B – FEBRUARY 1991 – REVISED JANUARY 1997

electrical characteristics over recommended operating free-air temperature range (unless otherwise noted)

PARAMETER	TEST CONDITIONS	T _A = 25°C			SN54ABT16652		SN74ABT16652		UNIT	
		MIN	TYP†	MAX	MIN	MAX	MIN	MAX		
V _{IK}	V _{CC} = 4.5 V, I _I = -18 mA			-1.2		-1.2		-1.2	V	
V _{OH}	V _{CC} = 4.5 V, I _{OH} = -3 mA	2.5			2.5		2.5		V	
	V _{CC} = 5 V, I _{OH} = -3 mA	3			3		3			
	V _{CC} = 4.5 V, I _{OH} = -24 mA	2			2					
V _{OL}	V _{CC} = 4.5 V, I _{OL} = 48 mA			0.55		0.55			V	
				0.55*			0.55			
V _{hys}			100						mV	
I _I	Control inputs	V _{CC} = 5.5 V, V _I = V _{CC} or GND			±1		±1		±1	μA
	A or B ports				±20		±20		±20	
I _{OZH} ‡	V _{CC} = 5.5 V, V _O = 2.7 V			10		10		10	μA	
I _{OZL} ‡	V _{CC} = 5.5 V, V _O = 0.5 V			-10		-10		-10	μA	
I _{off}	V _{CC} = 0, V _I or V _O ≤ 4.5 V			±100				±100	μA	
I _{CEX}	V _{CC} = 5.5 V, V _O = 5.5 V, Outputs high			50		50		50	μA	
I _O §	V _{CC} = 5.5 V, V _O = 2.5 V	-50	-100	-180	-50	-180	-50	-180	mA	
I _{CC}	A or B ports, V _{CC} = 5.5 V, I _O = 0, V _I = V _{CC} or GND	Outputs high			2		2		2	mA
		Outputs low			32		32		32	
		Outputs disabled			2		2		2	
ΔI _{CC} ¶	Data inputs	V _{CC} = 5.5 V, One input at 3.4 V, Other inputs at V _{CC} or GND, Outputs enabled			50		50		50	μA
		Outputs disabled			50		50		50	
	Control inputs	V _{CC} = 5.5 V, One input at 3.4 V, Other inputs at V _{CC} or GND			50		50		50	
C _i	Control inputs	V _I = 2.5 V or 0.5 V			4				pF	
C _{iO}	A or B ports	V _O = 2.5 V or 0.5 V			8				pF	

* On products compliant to MIL-PRF-38535, this parameter does not apply.

† All typical values are at V_{CC} = 5 V.

‡ The parameters I_{OZH} and I_{OZL} include the input leakage current.

§ Not more than one output should be tested at a time, and the duration of the test should not exceed one second.

¶ This is the increase in supply current for each input that is at the specified TTL voltage level rather than V_{CC} or GND.

SN54ABT16652, SN74ABT16652
16-BIT BUS TRANSCEIVERS AND REGISTERS
WITH 3-STATE OUTPUTS

SCBS215B – FEBRUARY 1991 – REVISED JANUARY 1997

timing requirements over recommended ranges of supply voltage and operating free-air temperature (unless otherwise noted) (see Figure 2)

	SN54ABT16652				UNIT
	V _{CC} = 5 V, T _A = 25°C		MIN	MAX	
	MIN	MAX			
f _{clock} Clock frequency	0	125	0	125	MHz
t _w Pulse duration, CLK high or low	4.3		4.3		ns
t _{su} Setup time, A or B before CLKAB↑ or CLKBA↑	3.5		4		ns
t _h Hold time, A or B after CLKAB↑ or CLKBA↑	0.5		0.5		ns

timing requirements over recommended ranges of supply voltage and operating free-air temperature (unless otherwise noted) (see Figure 2)

	SN74ABT16652				UNIT
	V _{CC} = 5 V, T _A = 25°C		MIN	MAX	
	MIN	MAX			
f _{clock} Clock frequency	0	125	0	125	MHz
t _w Pulse duration, CLK high or low	4.3		4.3		ns
t _{su} Setup time, A or B before CLKAB↑ or CLKBA↑	3		3		ns
t _h Hold time, A or B after CLKAB↑ or CLKBA↑	0		0		ns



SN54ABT16652, SN74ABT16652 16-BIT BUS TRANSCEIVERS AND REGISTERS WITH 3-STATE OUTPUTS

SCBS215B – FEBRUARY 1991 – REVISED JANUARY 1997

switching characteristics over recommended ranges of supply voltage and operating free-air temperature, $C_L = 50$ pF (unless otherwise noted) (see Figure 2)

PARAMETER	FROM (INPUT)	TO (OUTPUT)	SN54ABT16652				UNIT	
			$V_{CC} = 5$ V, $T_A = 25^\circ$ C			MIN		MAX
			MIN	TYP	MAX			
f_{max}			125			125	MHz	
t_{PLH}	CLK	B or A	1.5	3.1	4	1	5	ns
t_{PHL}			1.5	3.2	4.1	1	5	
t_{PLH}	A or B	B or A	1	2.3	3.2	0.6	4	ns
t_{PHL}			1	3	4.1	0.6	4.9	
t_{PLH}	SAB or SBA†	B or A	1	2.9	4.3	0.6	5.3	ns
t_{PHL}			1	3.1	4.6	0.6	5.3	
t_{PZH}	\overline{OEBA}	A	1	2.8	4.1	0.6	5.2	ns
t_{PZL}			1.5	3.1	4.4	1	5.4	
t_{PHZ}	\overline{OEBA}	A	1.5	3.4	4.7	0.8	5.3	ns
t_{PLZ}			1.5	2.7	4	1	5.3	
t_{PZH}	OEAB	B	1	2.6	3.6	0.8	4.7	ns
t_{PZL}			1.5	2.8	4.5	1	5	
t_{PHZ}	OEAB	B	2	4.2	5.9	1	6.4	ns
t_{PLZ}			1.5	3.4	4.9	1	5.9	

† These parameters are measured with the internal output state of the storage register opposite that of the bus input.

switching characteristics over recommended ranges of supply voltage and operating free-air temperature, $C_L = 50$ pF (unless otherwise noted) (see Figure 2)

PARAMETER	FROM (INPUT)	TO (OUTPUT)	SN74ABT16652				UNIT	
			$V_{CC} = 5$ V, $T_A = 25^\circ$ C			MIN		MAX
			MIN	TYP	MAX			
f_{max}			125			125	MHz	
t_{PLH}	CLK	B or A	1.5	3.1	4	1.5	4.9	ns
t_{PHL}			1.5	3.2	4.1	1.5	4.7	
t_{PLH}	A or B	B or A	1	2.3	3.2	1	3.9	ns
t_{PHL}			1	3	4.1	1	4.6	
t_{PLH}	SAB or SBA†	B or A	1	2.9	4.3	1	5	ns
t_{PHL}			1	3.1	4.3	1	5	
t_{PZH}	\overline{OEBA}	A	1	2.8	4.1	1	5	ns
t_{PZL}			1.5	3.1	4.4	1.5	5.3	
t_{PHZ}	\overline{OEBA}	A	1.5	3.4	4.4	1.5	4.9	ns
t_{PLZ}			1.5	2.7	3.6	1.5	4	
t_{PZH}	OEAB	B	1	2.6	3.6	1	4.2	ns
t_{PZL}			1.5	2.8	3.9	1.5	4.6	
t_{PHZ}	OEAB	B	2	4.2	5.5	2	5.9	ns
t_{PLZ}			1.5	3.4	4.5	1.5	5.2	

† These parameters are measured with the internal output state of the storage register opposite that of the bus input.

SN54ABT16652, SN74ABT16652 16-BIT BUS TRANSCEIVERS AND REGISTERS WITH 3-STATE OUTPUTS

SCBS215B – FEBRUARY 1991 – REVISED JANUARY 1997

PARAMETER MEASUREMENT INFORMATION

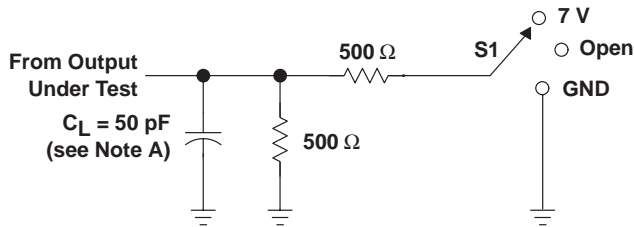

LOAD CIRCUIT

TEST	S1
t_{PLH}/t_{PHL}	Open
t_{PLZ}/t_{PZL}	7 V
t_{PHZ}/t_{PZH}	Open

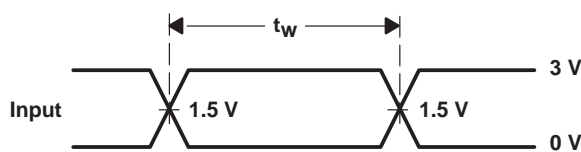

VOLTAGE WAVEFORMS
PULSE DURATION

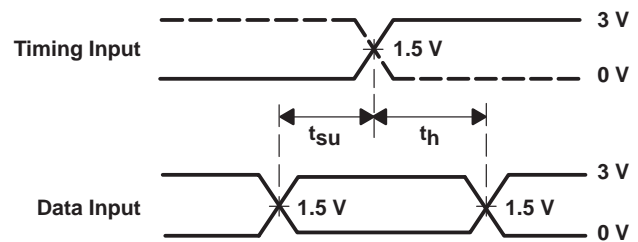

VOLTAGE WAVEFORMS
SETUP AND HOLD TIMES

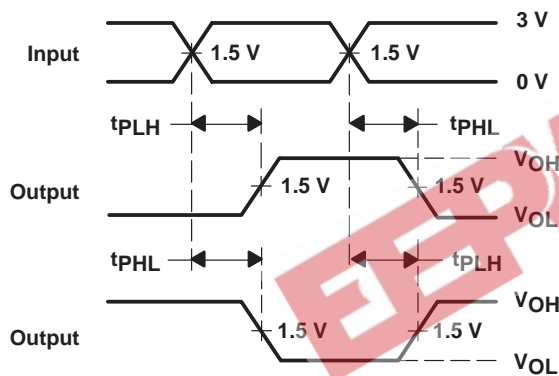

VOLTAGE WAVEFORMS
PROPAGATION DELAY TIMES
INVERTING AND NONINVERTING OUTPUTS

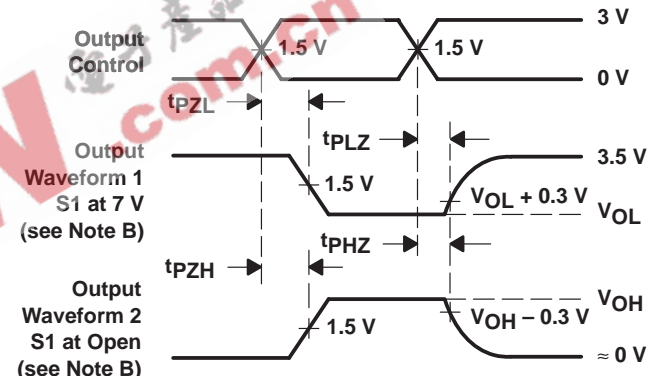

VOLTAGE WAVEFORMS
ENABLE AND DISABLE TIMES
LOW- AND HIGH-LEVEL ENABLING

- NOTES: A. C_L includes probe and jig capacitance.
B. Waveform 1 is for an output with internal conditions such that the output is low except when disabled by the output control. Waveform 2 is for an output with internal conditions such that the output is high except when disabled by the output control.
C. All input pulses are supplied by generators having the following characteristics: $PRR \leq 10 \text{ MHz}$, $Z_O = 50 \Omega$, $t_r \leq 2.5 \text{ ns}$, $t_f \leq 2.5 \text{ ns}$.
D. The outputs are measured one at a time with one transition per measurement.

Figure 2. Load Circuit and Voltage Waveforms

PACKAGING INFORMATION

Orderable Device	Status ⁽¹⁾	Package Type	Package Drawing	Pins	Package Qty	Eco Plan ⁽²⁾	Lead/Ball Finish	MSL Peak Temp ⁽³⁾
5962-9584101QXA	ACTIVE	CFP	WD	56	1	TBD	Call TI	Level-NC-NC-NC
SN74ABT16652DL	ACTIVE	SSOP	DL	56	20	Green (RoHS & no Sb/Br)	CU NIPDAU	Level-1-260C-UNLIM
SN74ABT16652DLG4	ACTIVE	SSOP	DL	56	20	Green (RoHS & no Sb/Br)	CU NIPDAU	Level-1-260C-UNLIM
SN74ABT16652DLR	ACTIVE	SSOP	DL	56	1000	Green (RoHS & no Sb/Br)	CU NIPDAU	Level-1-260C-UNLIM
SN74ABT16652DLRG4	ACTIVE	SSOP	DL	56	1000	Green (RoHS & no Sb/Br)	CU NIPDAU	Level-1-260C-UNLIM
SNJ54ABT16652WD	ACTIVE	CFP	WD	56	1	TBD	Call TI	Level-NC-NC-NC

⁽¹⁾ The marketing status values are defined as follows:

ACTIVE: Product device recommended for new designs.

LIFEBUY: TI has announced that the device will be discontinued, and a lifetime-buy period is in effect.

NRND: Not recommended for new designs. Device is in production to support existing customers, but TI does not recommend using this part in a new design.

PREVIEW: Device has been announced but is not in production. Samples may or may not be available.

OBSOLETE: TI has discontinued the production of the device.

⁽²⁾ Eco Plan - The planned eco-friendly classification: Pb-Free (RoHS) or Green (RoHS & no Sb/Br) - please check <http://www.ti.com/productcontent> for the latest availability information and additional product content details.

TBD: The Pb-Free/Green conversion plan has not been defined.

Pb-Free (RoHS): TI's terms "Lead-Free" or "Pb-Free" mean semiconductor products that are compatible with the current RoHS requirements for all 6 substances, including the requirement that lead not exceed 0.1% by weight in homogeneous materials. Where designed to be soldered at high temperatures, TI Pb-Free products are suitable for use in specified lead-free processes.

Green (RoHS & no Sb/Br): TI defines "Green" to mean Pb-Free (RoHS compatible), and free of Bromine (Br) and Antimony (Sb) based flame retardants (Br or Sb do not exceed 0.1% by weight in homogeneous material)

⁽³⁾ MSL, Peak Temp. -- The Moisture Sensitivity Level rating according to the JEDEC industry standard classifications, and peak solder temperature.

Important Information and Disclaimer:The information provided on this page represents TI's knowledge and belief as of the date that it is provided. TI bases its knowledge and belief on information provided by third parties, and makes no representation or warranty as to the accuracy of such information. Efforts are underway to better integrate information from third parties. TI has taken and continues to take reasonable steps to provide representative and accurate information but may not have conducted destructive testing or chemical analysis on incoming materials and chemicals. TI and TI suppliers consider certain information to be proprietary, and thus CAS numbers and other limited information may not be available for release.

In no event shall TI's liability arising out of such information exceed the total purchase price of the TI part(s) at issue in this document sold by TI to Customer on an annual basis.

MECHANICAL DATA

MCFP010B – JANUARY 1995 – REVISED NOVEMBER 1997

WD (R-GDFP-F**)

CERAMIC DUAL FLATPACK

48 LEADS SHOWN

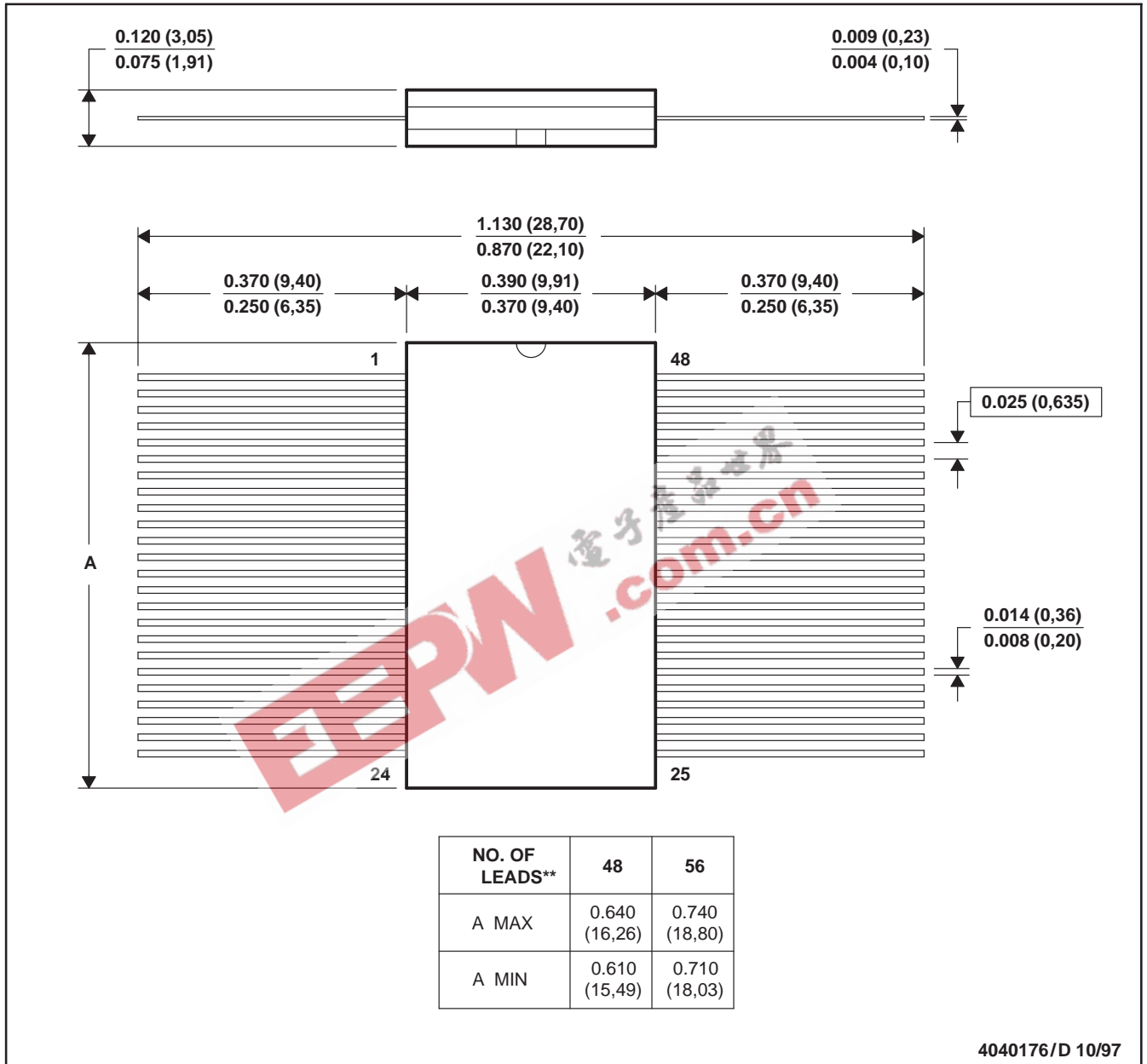

- NOTES: A. All linear dimensions are in inches (millimeters).
 B. This drawing is subject to change without notice.
 C. This package can be hermetically sealed with a ceramic lid using glass frit.
 D. Index point is provided on cap for terminal identification only
 E. Falls within MIL STD 1835: GDFP1-F48 and JEDEC MO-146AA
 GDFP1-F56 and JEDEC MO-146AB

MECHANICAL DATA

MSS0001C – JANUARY 1995 – REVISED DECEMBER 2001

DL (R-PDSO-G**)

PLASTIC SMALL-OUTLINE PACKAGE

48 PINS SHOWN

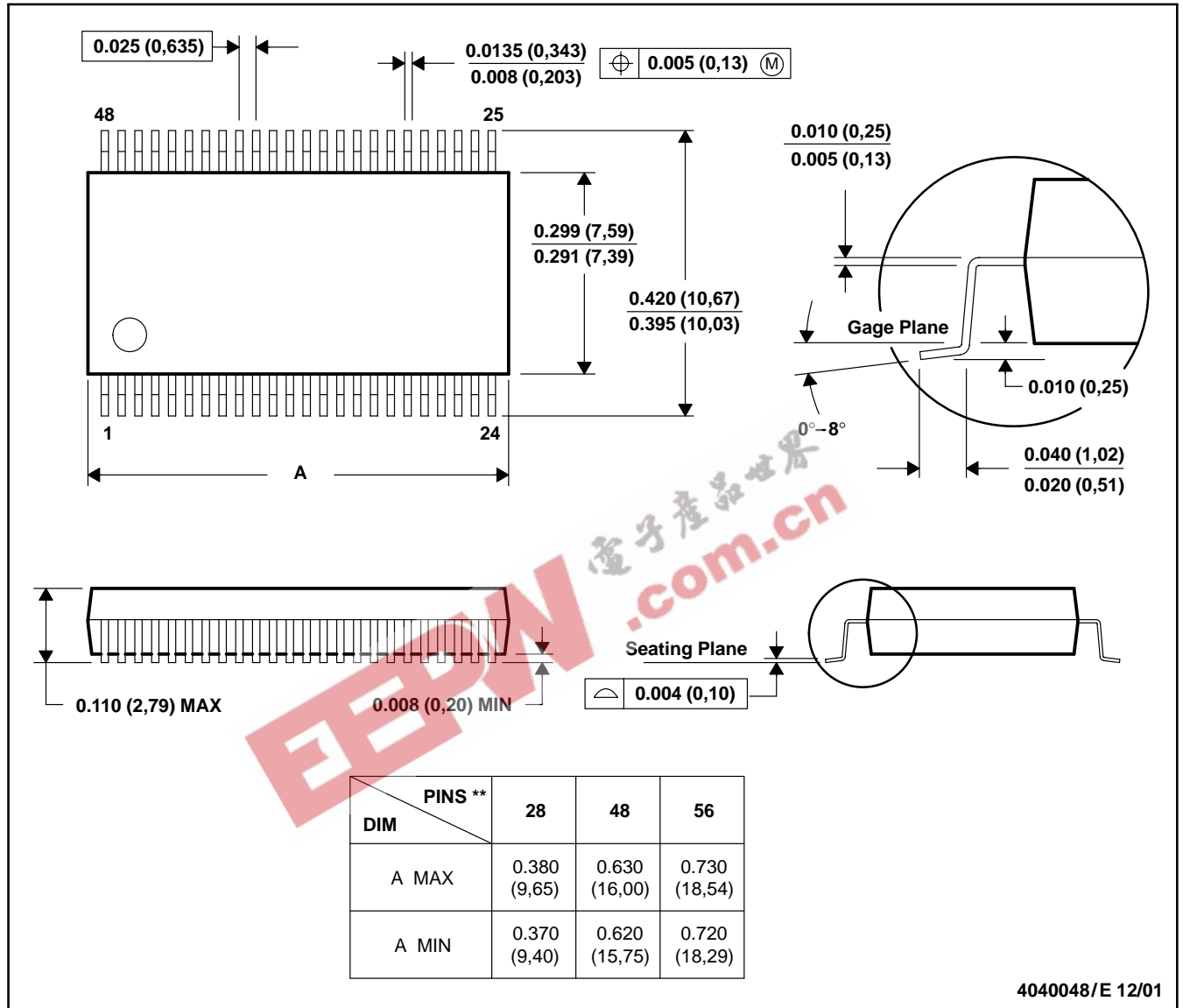

- NOTES: A. All linear dimensions are in inches (millimeters).
 B. This drawing is subject to change without notice.
 C. Body dimensions do not include mold flash or protrusion not to exceed 0.006 (0,15).
 D. Falls within JEDEC MO-118

IMPORTANT NOTICE

Texas Instruments Incorporated and its subsidiaries (TI) reserve the right to make corrections, modifications, enhancements, improvements, and other changes to its products and services at any time and to discontinue any product or service without notice. Customers should obtain the latest relevant information before placing orders and should verify that such information is current and complete. All products are sold subject to TI's terms and conditions of sale supplied at the time of order acknowledgment.

TI warrants performance of its hardware products to the specifications applicable at the time of sale in accordance with TI's standard warranty. Testing and other quality control techniques are used to the extent TI deems necessary to support this warranty. Except where mandated by government requirements, testing of all parameters of each product is not necessarily performed.

TI assumes no liability for applications assistance or customer product design. Customers are responsible for their products and applications using TI components. To minimize the risks associated with customer products and applications, customers should provide adequate design and operating safeguards.

TI does not warrant or represent that any license, either express or implied, is granted under any TI patent right, copyright, mask work right, or other TI intellectual property right relating to any combination, machine, or process in which TI products or services are used. Information published by TI regarding third-party products or services does not constitute a license from TI to use such products or services or a warranty or endorsement thereof. Use of such information may require a license from a third party under the patents or other intellectual property of the third party, or a license from TI under the patents or other intellectual property of TI.

Reproduction of information in TI data books or data sheets is permissible only if reproduction is without alteration and is accompanied by all associated warranties, conditions, limitations, and notices. Reproduction of this information with alteration is an unfair and deceptive business practice. TI is not responsible or liable for such altered documentation.

Resale of TI products or services with statements different from or beyond the parameters stated by TI for that product or service voids all express and any implied warranties for the associated TI product or service and is an unfair and deceptive business practice. TI is not responsible or liable for any such statements.

Following are URLs where you can obtain information on other Texas Instruments products and application solutions:

Products		Applications	
Amplifiers	amplifier.ti.com	Audio	www.ti.com/audio
Data Converters	dataconverter.ti.com	Automotive	www.ti.com/automotive
DSP	dsp.ti.com	Broadband	www.ti.com/broadband
Interface	interface.ti.com	Digital Control	www.ti.com/digitalcontrol
Logic	logic.ti.com	Military	www.ti.com/military
Power Mgmt	power.ti.com	Optical Networking	www.ti.com/opticalnetwork
Microcontrollers	microcontroller.ti.com	Security	www.ti.com/security
		Telephony	www.ti.com/telephony
		Video & Imaging	www.ti.com/video
		Wireless	www.ti.com/wireless

Mailing Address: Texas Instruments
Post Office Box 655303 Dallas, Texas 75265