

Hercules Encoders

Series 4000

Heavy Duty Incremental Rotary Shaft Encoder

- Enclosure: SLIMLINE — 3" x 3" x 1½" Space-Saver NEMA 12/13 or NEMA 4 type Sealing — Flush or Flanged Base Styles
- Inherently Anti-Jitter Circuitry, Shatterproof Metal Code Discs
- Internally and Externally Shielded ABEC 5 Stainless Steel Bearings, Mounted Internally
- Low Supply Current Requirement — 30milliamps typical per encoder, maximum of 50 mA
- Operating Voltage Flexibility — 8 to 28 Vdc or 5 Vdc TTL Output, 5V or 8-15V with Line Driver
- Operating Temperature Rating designed for extremes, from -40° to +85° C (-40° to +185° F)

Specifications

Mechanical

Shaft Speed	6000 RPM maximum
Shaft Direction	Bidirectional
Standard Shaft Sizes (Dia.)	.2497", .3747", .4997"
Shaft Extension(s)	0.80" with .50x.05" flat
Shaft Seals	Neoprene or PTFE Options
Mounting	Refer to dimensional drawings
Bearings	ABEC 5 Shielded
Radial Loading	(3/8") 30 lbs. Operating (1/2") 70 lbs. Operating
Axial Loading	(3/8") 15 lbs. Operating (1/2") 35 lbs. Operating
Accuracy	±0.1° of Shaft Rotation Typical
Housing	Black Anodized Aluminum
Weight	Standard: 17 oz., Sealed: 26 oz.
Connector	6 Pin MS3102 or 18" Cable Out

Electrical

Pulse Rate	10 kHz, up to 200 kHz
Outputs	NPN w/ pullup; NPN open collector; PNP sourcing Line Drivers (5 Vdc/ TTL level, 8 to 15 Vdc) All line drivers have complementary outputs.
Output Ratings	
Open Collector Transistor	40 Vdc maximum
Line Drivers 8-15 Vdc	15 Vdc maximum
5 Vdc TTL	5.5 Vdc maximum
Supply Voltage	8 to 28 Vdc 5 Vdc with 5V TTL level output
Supply Current	30 mA typical, 50 mA maximum
Current Sinking	250 mA maximum
Output Duty Cycle	50/50 w/ ±20% typical tolerance Tighter to ±5% by spec
Pulsed Outputs	5-10 µsec or 25-35 µsec
Rise/Fall Times	1 µsec typical, other options available
	See Wiring Diagrams for Pin Outs

Environmental

Operating Temp.	-40° to +85° C (-40° to +185° F)
Shock	50 g's for 11 Milliseconds
Vibration	5 to 2000 Hertz at 20 g's
Humidity	100% Relative Humidity
Enclosures (Sealed)	NEMA 4 type — Water-tight
(Std)	NEMA 12/13 equiv. — Dust-, Oil-Tight

Electrical Connections

Function	Pin	Color
+V	B	Red
Common	A	Black
Channel A	D	Blue
Channel B	E	Brown
Channel \bar{A}	C	White
Channel \bar{B}	F	Green

For the latest specifications visit our website
www.herculesencoders.com



Dimensional Drawings

Series 4000 Standard *call for sealed dimensions*

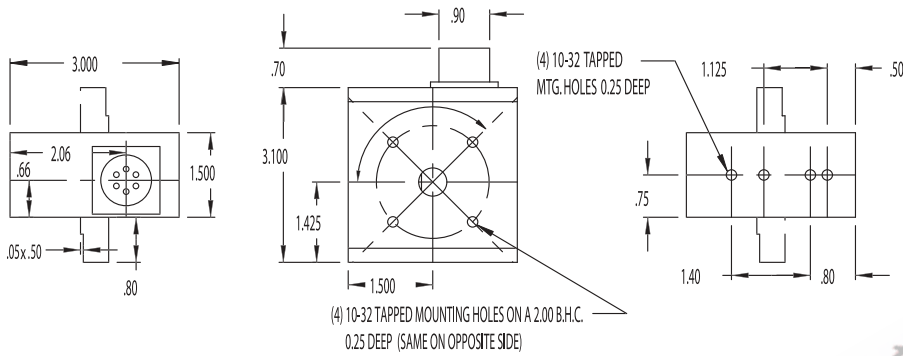

Wire Drawings



+8 to +28Vdc *Maximum of 18Vdc for "D" output
*3.3K pullup on "A", Not installed on "B", 1.5K on "D"

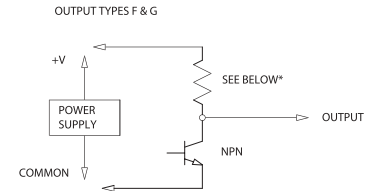

+5 Vdc
*3.3K Pullup on "F", Not installed on "G"



+8 TO +28Vdc

OUTPUT TYPES K & L

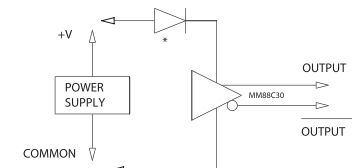

+8 TO +15Vdc on "L", +5V on "K"
*Only installed on "L"

Ordering Information

Series **4 4 2 1** Encoder Type **A Q** PPR (Pulses per Revolution) **0600**

Shaft Diameter
1=1/4" (0.2497")
3=3/8" (0.3747)
4=1/2" (0.4997)

Shaft Extension
1=Single
2=Double

Mounting Type
1=10-32 BHC on Shaft Ends & Base
2=Flanged Base (BHC on Shaft Ends)

Encoder Type
_=Standard Encoder
S=Sealed (Elastomer)
T=Sealed (PTFE)

Channel Outputs
A=NPN 3.3K Pullup
B=NPN Open Collector
D=NPN 1.5K Pullup
F=5Vdc TTL NPN w/Pullup
G=5Vdc TTL NPN OC
H=PNP Sourcing Output
K=5Vdc Line Driver
L=8 to 15 Vdc Line Driver

Channel Types
S=Single Output
Q=Quadrature Output
P=1st Output CW Pulses
2nd Output CCW Pulses
U=1st Output Pulse Train
2nd Output Logic High for CW Rotation. Low for CCW Rotation

PPR (Pulses per Revolution)

For all Channel Types

0025	0030	0050	0060	0075	0090	0093
0096	0100	0120	0125	0128	0135	0150
0180	0186	0192	0200	0210	0240	0250
0256	0270	0300	0360	0372	0400	0420
0480	0500	0512	0540	0600	0720	0840
0960	1000	1024				

Added Channel Types "S" "P" "U" (Square Wave)

0384 0744 0800 1080 1200 1440 1680 1920 2000 2048

Added "S" "P" "U" (5-10 & 25-35 μSec Pulses)

0768 1488 1600 2160 2400 2880 3360 3840 4000 4096

Consult factory for PPR not listed