

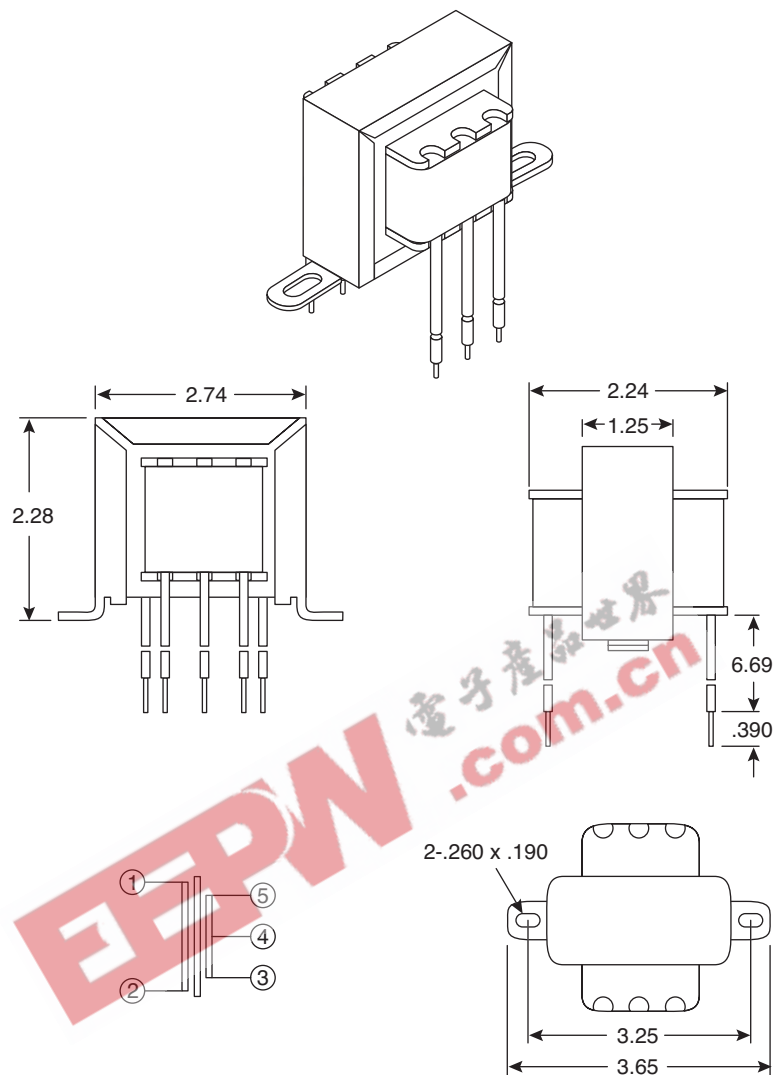

Power Transformer

41FJ020



Dimensions: In.

Specifications:

- Primary voltage: 115VAC 60Hz
- Primary exciting current: 100mA (max.)
- Secondary voltage (no load): 20.6CT VAC \pm 0.8V%
- Secondary voltage (full load): 18.0CT VAC \pm 0.8V%
- Rated secondary current: 2.0 Amperes (AC) 60Hz
- Voltage regulation: less than 15% (VNL-VFL)/(VFL)x100
- Temperature rise (@ room temp. 25°C): less than 95°C
- Breakdown voltage (HiPOT): 2000VAC 50Hz, 1minute
- Coil to coil insulation: 100M Ω (min.) 500VDC
- Strain relief: 10 lbs.
- Channel frame material & thickness: iron 0.4"
- Crossover insulation: .002" polyester tape
- Primary winding: SWG28
- Secondary winding: SWG22+28
- Core size: EI-66
- Core material: hilite core H-23 .02"
- Inner insulation: 3 layers of .002" polyester tape
- Outer wrap insulation: 3 layers of 0.05mm polyester tape w/1 pc. of fiber board (yellow)
- Bobbin: nylon, normal type .87" x 1.8"
- Impregnation: varnish
- Lead wire: Pri. AWG22, Sec. AWG18 or AWG22

