

**Cathode to Stud Shown**  
**(Anode to Stud add Suffix R)**

Symbol



**MAXIMUM RATINGS** ( $T_j = 25^\circ C$  unless stated otherwise)

Parameter	Symbol	40HF(R) -10	40HF(R) -20	40HF(R) -40	40HF(R) -60	40HF(R) -80	40HF(R) -100	40HF(R) -120	40HF(R) -140	40HF(R) -160	Unit
Repetitive Peak Reverse Voltage	$V_{RRM}$	100	200	400	600	800	1000	1200	1400		Volt
Maximum Average On-State Current	$I_{F(AV)}$	40 at $t_j = 140^\circ C$							40 at $t_j = 110^\circ C$		Amp
Peak Forward Surge Current 8.3ms	$I_{FSM}$	595							500		Amp
Maximum $I^2T$ for Fusing 8.3ms	$I^2T$	1450							1050		A <sup>2</sup> /S
Maximum Storage Temperature Range	$T_{(STG)}$	-40 to +190							-65 to +160		$^\circ C$
Maximum Junction Temperature Range	$T_j$	-40 to +190							-65 to +160		$^\circ C$

**ELECTRICAL CHARACTERISTICS** at  $T_j = 25^\circ C$  Maximum. Unless stated Otherwise

Parameter	Symbol	Condition	Value			Unit
			Min	Typ	Max	
Maximum Forward Voltage	$V_{FM}$	$I_{FM} = 125$ Amps (100 -1200V )			1.30	Volt
Maximum Forward Voltage	$V_{FM}$	$I_{FM} = 125$ Amps (1400 -1600V )			1.50	Volt
Repetitive Peak Reverse Current	$I_{RRM}$	$V_R = V_{RRM}$ , $t_j = t_j$ Max(100 -1200V )			9.0	mA
Repetitive Peak Reverse Current	$I_{RRM}$	$V_R = V_{RRM}$ , $t_j = t_j$ Max(1400 -1600V )			4.5	mA
Thermal Resistance (Junction to Case)	$R_{TH(j-c)}$				0.95	$^\circ C/W$
Mounting Torque	$M_T$				2.5	NM
Weight	Wt				17	grms

**Mechanical Outline**

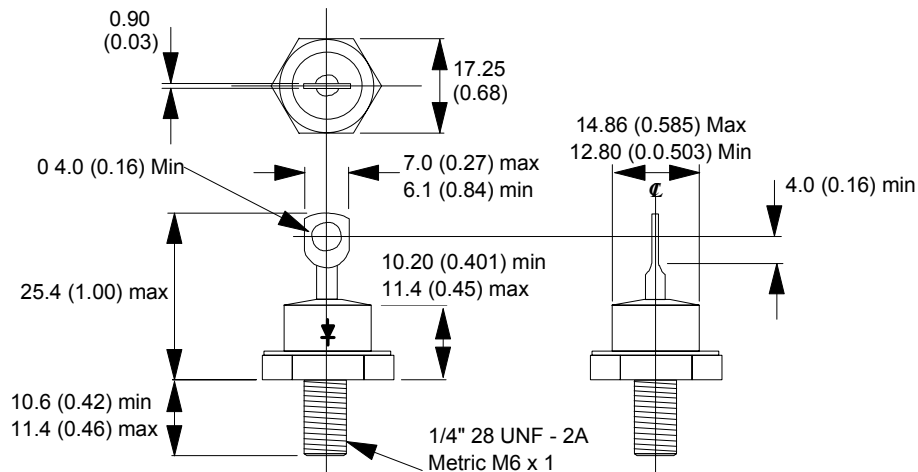

Case: DO-203AB (DO-5)

Case: Metal/ Glass to Metal Seal  
All Dimensions in Millimeters (Inches)