



FEATURES

- Standard 7.0x5.0mm Surface Mount Footprint
- Stable Frequency Over Temperature and Drive Level
- Frequency Range 8 – 100 MHz
- Frequency Tolerance, ± 30 ppm Standard (± 10 ppm and ± 20 ppm available)
- Frequency Stability, ± 50 ppm Standard ($\pm 10, \pm 20, \pm 30$ and ± 40 ppm available)
- Operating Temperature to -40°C to $+85^{\circ}\text{C}$
- Tape & Reel Packaging, EIA-481-2 Compliant
- **RoHS/Green Compliant**

DESCRIPTION

The Model 407 is a ceramic packaged Crystal offering reduced size, ideal for high-density circuit board applications. The Model 407 offers reliable precision and excellent shock performance in wireless telecommunication devices.



ORDERING INFORMATION

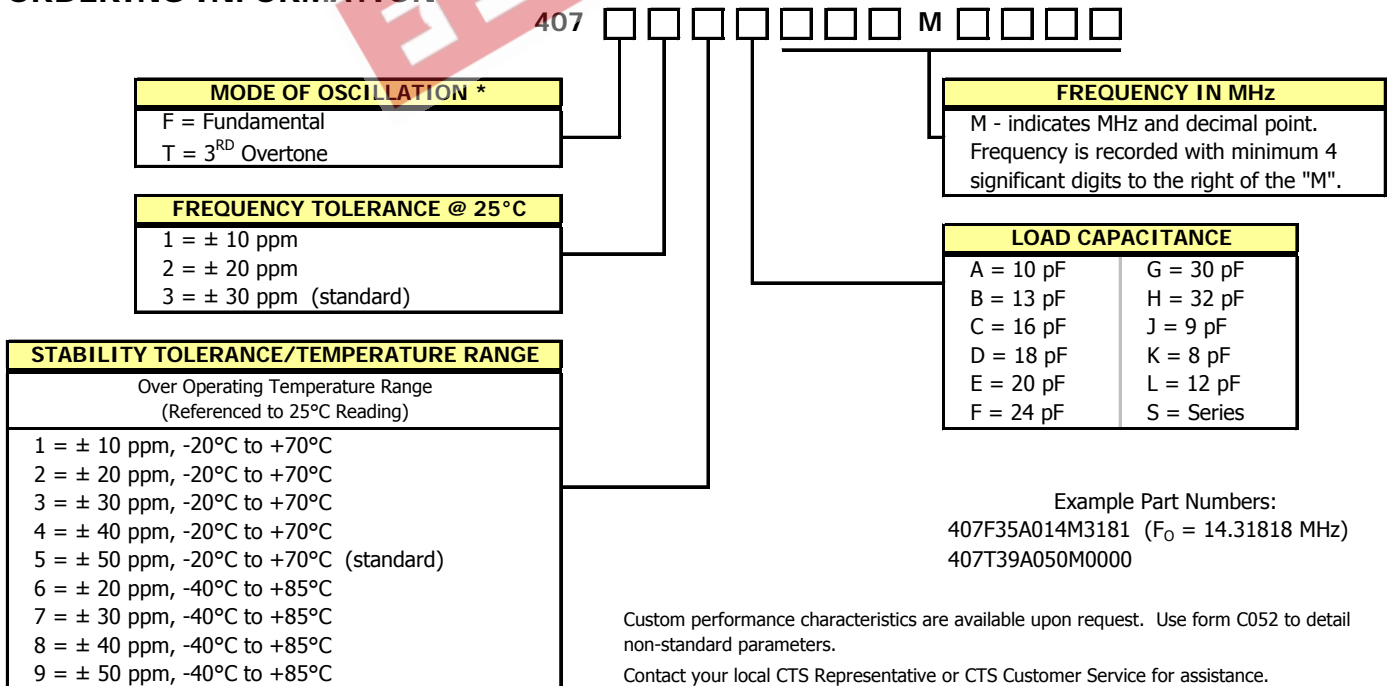

* Prior to 11/7/06 the part number format did not contain this designator. These "Old Format" numbers (008-0261-0 Rev. E) are still valid with frequencies less than or equal to 48.0000 MHz as Fundamental Mode designs. Frequencies above 48.0000 MHz will be Third Overtone designs. Refer to PCM-1211 for more details.

ELECTRICAL CHARACTERISTICS

	PARAMETER	VALUE
Electrical Parameters	Operating Mode (Note 1)	Fundamental or 3 RD Overtone
	Crystal Cut	AT-Cut
	Frequency Range	8.0 MHz to 100.0 MHz
	Frequency Tolerance @ 25°C	± 30 ppm Standard (± 10 ppm and ± 20 ppm Available)
	Frequency Stability Tolerance (Operating Temperature Range, Referenced to 25°C Reading)	± 50 ppm Standard (± 10 ppm, ± 20 ppm, ± 30 ppm and ± 40 ppm Available)
	Operating Temperature Range	-20°C to +70°C Standard (-40°C to +85°C Available)
	Storage Temperature Range	-55°C to +125°C
	Equivalent Series Resistance	See ESR Table
	Load Capacitance or Resonance Mode	See Ordering Information
	Shunt Capacitance (C ₀)	4.0 pF Maximum (2.5 pF ± 0.5 pF Typical)
	Drive Level	25 µW Typical, 100 µW Maximum
	Reflow Condition, per JEDEC J-STD-020	+255°C ± 5°C, 10 Seconds Maximum

EQUIVALENT SERIES RESISTANCE TABLE

FREQUENCY RANGE	MODE of OSCILLATION	ESR Maximum
8.000 MHz - 15.999 MHz	Fundamental	60 Ohms
16.000 MHz - 50.000 MHz	Fundamental	40 Ohms
30.001 MHz - 60.000 MHz	3 RD Overtone	100 Ohms
60.001 MHz - 100.000 MHz	3 RD Overtone	80 Ohms

MECHANICAL SPECIFICATIONS

PACKAGE DRAWING

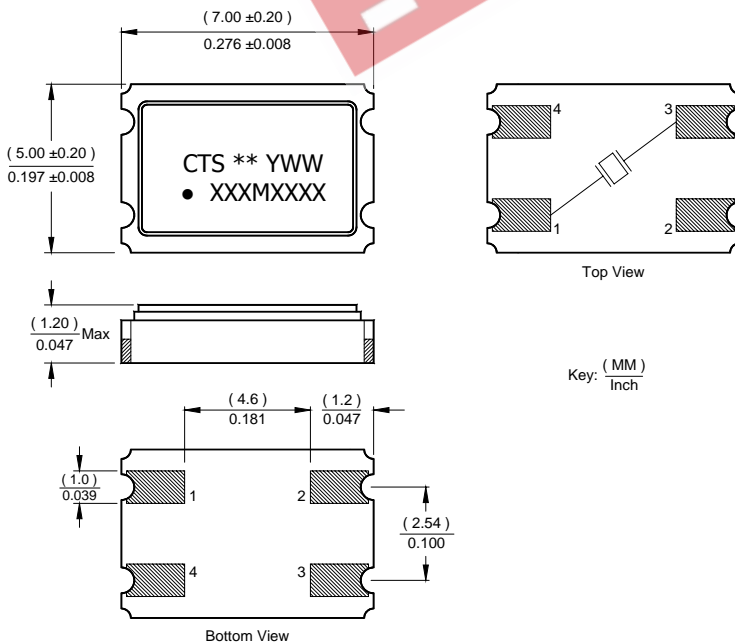

MARKING INFORMATION

- ** - Manufacturing Site Code.
- YWW – Date Code, Y – Last Digit of Year, WW – Week.
- XXXMXXXX – Frequency marked with 4 significant digits after the 'M'.
- Complete CTS part number, frequency value and date code information must appear on reel and box labels.

SUGGESTED SOLDER PAD GEOMETRY

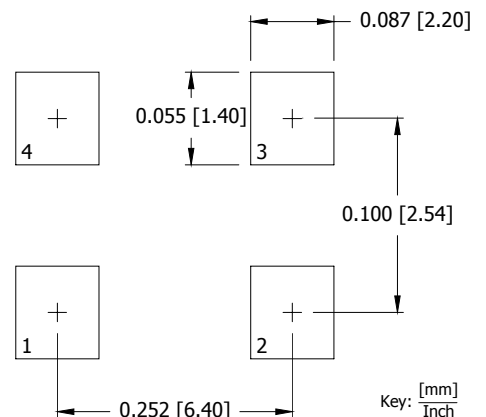

Notes:

- Termination pads (e4), barrier-plating is nickel (Ni) with gold (Au) flash plate.
- Terminations #2, #4 and the metal lid are connected internally. End user may connect these pins to circuit ground.

TAPE AND REEL INFORMATION

DIMENSIONS IN MILLIMETERS

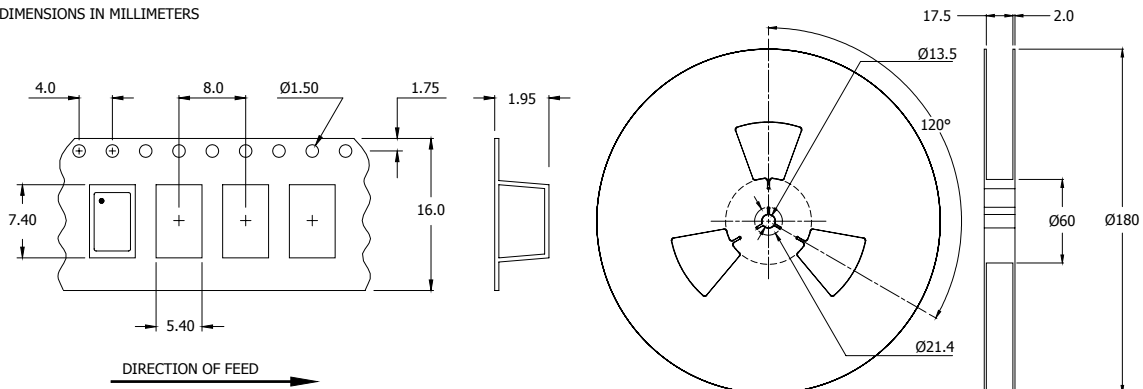

Device quantity is 1,000 pieces per 180mm reel.

ENVIRONMENTAL SPECIFICATIONS

Temperature Cycle:	400 cycles from -55°C to $+125^{\circ}\text{C}$, 10 minute dwell at each temperature, 1 minute transfer time between temperatures.
Mechanical Shock:	1,500g's, 0.5mS duration, $\frac{1}{2}$ sinewave, 3 shocks each direction along 3 mutually perpendicular planes (18 total shocks).
Sinusoidal Vibration:	0.06 inches double amplitude, 10 to 55 Hz and 20g's, 55 to 2,000 Hz, 3 cycles each in 3 mutually perpendicular planes (9 times total).
Gross Leak:	No leak shall appear while immersed in an FC40 or equivalent liquid at $+125^{\circ}\text{C}$ for 20 seconds.
Fine Leak:	Mass spectrometer leak rates less than 2×10^{-8} ATM cc/sec air equivalent.
Resistance to Solder Heat:	Product must survive 3 reflows of $+260^{\circ}\text{C}$ peak, 10 seconds maximum.
High Temperature Operating Bias:	2,000 hours at $+125^{\circ}\text{C}$, disregarding frequency shift.
Frequency Aging:	1,000 hours at $+85^{\circ}\text{C}$, maximum ± 5 ppm shift.
Insulation Resistance:	500M Ohms @ $100\text{V}_{\text{DC}} \pm 15\text{V}_{\text{DC}}$.
Moisture Sensitivity Level:	Level 1 per JEDEC J-STD-020.

QUALITY AND RELIABILITY

Quality systems meet or exceed the requirements of ISO 9000:2000 standards.