

**TWO LINE PAIR 4-20mA CONTROL LOOP PROTECTOR**
**APPLICATIONS**

- ✓ Multi-Process Control Loops
- ✓ Fire & Security Systems
- ✓ Petro-Chemical Plants
- ✓ Refineries & Tank Farms

**IEC COMPATIBILITY (EN61000-4)**

- ✓ 61000-4-2 (ESD): Air - 15kV, Contact - 8kV
- ✓ 61000-4-4 (EFT): 40A - 5/50ns
- ✓ 61000-4-5 (Surge): 8/20 $\mu$ s - 95A, Level 4 (Line-Gnd) & 48A, Level 4 (Line-Line)

**FEATURES**

- ✓ Designed for 4-20mA Current Loops
- ✓ Automatic Reset - Does Not Interrupt Service
- ✓ Permanent Two-Stage Line Pair Protection
- ✓ Common Mode & Differential Mode Protection
- ✓ Subnanosecond Response Time
- ✓ Effective Against Lightning, Inductive Switching and ESD

**MECHANICAL CHARACTERISTICS**

- ✓ Weight: 420LB - 28 grams & 420LE - 142 grams (Approximate)
- ✓ Flammability Rating UL 94V-0
- ✓ Device Marking:
  - Case - Logo, Terminal Designations & Part Number
  - Board - Logo, Date Code & Part Number

**DESCRIPTION**

The 420LE/B series is a two stage transient voltage protector providing primary and secondary protection against lightning, inductive switching and electrostatic discharge (ESD) transient threats. The first stage diverts the transient current through the ground terminal return path and the second stage clamps the voltage to a safe level without interruption of service.

The 420LE/B series is designed to protect data lines from differential (line to line) and common mode (line to ground) transients. Terminals 1 and 2, 3 and 4 for the 420LE and pins 2 and 3, 4, and 5 for the 420LB are designated as line pairs. Each line pair is referenced to ground. A transient voltage suppressor is connected across each line pair for differential mode protection. Each line pair is referenced to ground.

This product can also be used on telephone, signal/data lines, security, timing and control interface circuits. For most applications, the product should be located as close as possible to the equipment being protected. A low impedance grounding system is important to maintain a low voltage clamp between the line-to-ground connection.

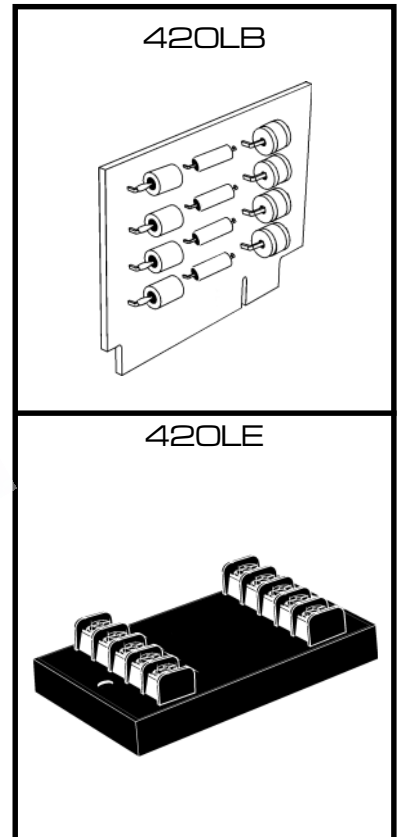

# 420LE28 thru 420LB60

## DEVICE CHARACTERISTICS

MAXIMUM RATINGS @ 25°C		ELECTRICAL CHARACTERISTICS @ 25°C Ambient Temperature					
Operating Line Current	100mA	PROTEK PART NUMBER	MAXIMUM OPERATING LINE VOLTAGE	MAXIMUM LEAKAGE CURRENT	MAXIMUM CLAMPING VOLTAGE (8/20µs) @2,000A	MAXIMUM CAPACITANCE	MAXIMUM LINE THRUPTUT RESISTANCE
Operating Temperature	-55 to 100°C		$V_{OP}$	@ $V_{OP}$	$V_C$	@ 0V, 1 MHz	R
Storage Temperature	-55 to 100°C		± VOLTS	$I_D$	VOLTS	C	OHMS
Transient Source Voltage	6kV			µA		pF	
Transient Current (8/20µs)	10kA						
		420LE28	28.0	5.0	40	2800	12
		420LE35	35.0	5.0	60	1500	12
		420LE60	60.0	5.0	85	1000	12
		420LB28	28.0	5.0	40	2800	12
		420LB35	35.0	5.0	60	1500	12
		420LB60	60.0	5.0	85	1000	12

## INSTALLATION INSTRUCTIONS

There are five (5) terminals on the **LINE SIDE** and five (5) terminals on the **EQUIPMENT SIDE** of the 420LE, 4 data lines and one ground. Both grounds are connected together internally. A single low impedance is ground sufficient. Incoming data lines are cut or disconnected from the equipment to insert the 420LE/B products. The incoming lines are to be connected to the line side terminals as the equipment side lines are connected to the equipment side terminals. The location of the product should be as close to the equipment as possible. The 420LE/B series is designed with a short circuit failure mode to give maximum protection. A fuse, fusable link, or circuit breaker is recommended for each data/signal line on the input side for those that require an open circuit failure mode.

**Caution:** A low DC resistance ground may not be indicative of a good lightning ground. Lightning contains a broad spectrum of frequencies up to 1 MHz. A low impedance path to ground at the transient frequencies is necessary. A ground strap is recommended or a #6 AWG stranded wire. For wire lengths over 1.5 meters, there may be some excessive line to earth potential under severe thunderstorm conditions.

# 420LE28 thru 420LB60

## PACKAGE OUTLINE & DIMENSIONS

### 420LE CASE OUTLINE

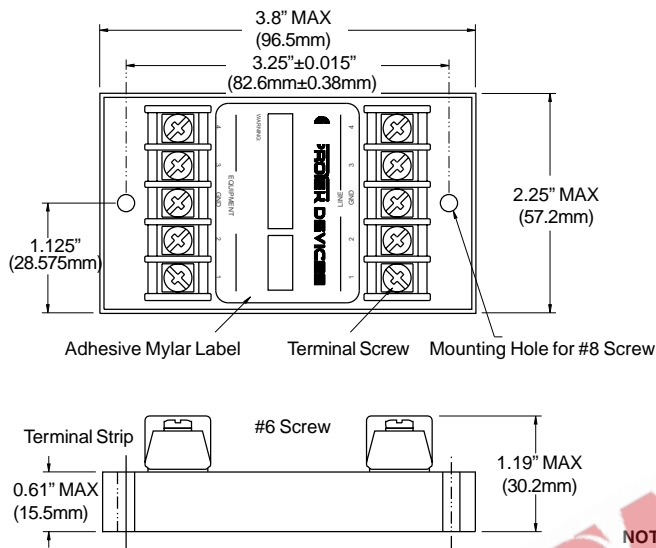

### 420LB BOARD OUTLINE

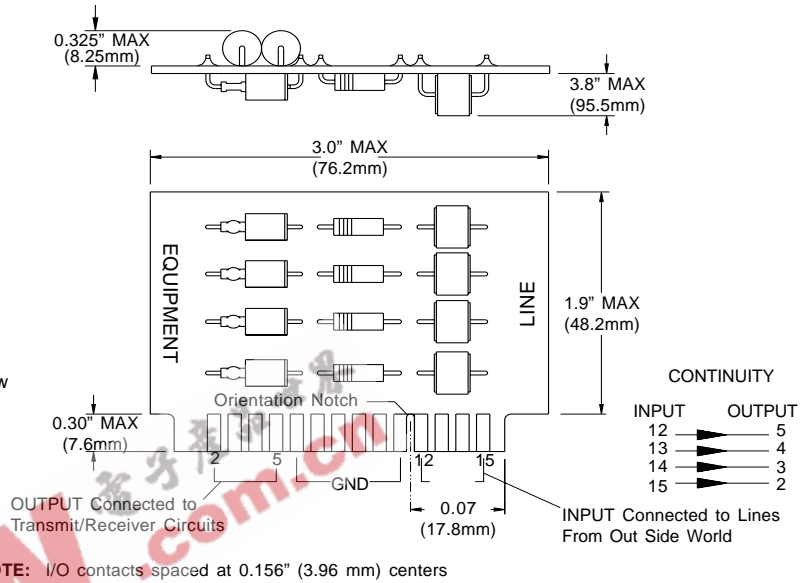

COPYRIGHT © ProTek Devices 2003

SPECIFICATIONS: ProTek reserves the right to change the electrical and or mechanical characteristics described herein without notice (except JEDEC).

DESIGN CHANGES: ProTek reserves the right to discontinue product lines without notice, and that the final judgement concerning selection and specifications is the buyer's and that in furnishing engineering and technical assistance, ProTek assumes no responsibility with respect to the selection or specifications of such products.

**ProTek Devices**

2929 South Fair Lane, Tempe, AZ 85282

Tel: 602-431-8101 Fax: 602-431-2288

E-Mail: [sales@protekdevices.com](mailto:sales@protekdevices.com)

Web Site: [www.protekdevices.com](http://www.protekdevices.com)