

AND8098/D

Low-Cost 100 mA High-Voltage Buck and Buck-Boost Using NCP1052

Prepared by: Kahou Wong
ON Semiconductor



ON Semiconductor®

<http://onsemi.com>

APPLICATION NOTE

INTRODUCTION

This application note presents low-cost high-voltage 100 mA non-isolated power supply using NCP1052 by buck and buck-boost topology. The NCP1052 is one of the latest low-cost switching controllers with integrated 700 V/300 mA power switch from ON Semiconductor. It is primarily designed for isolated 10 W-range flyback converter. If isolation is not needed, the IC can also be used as stepping-down buck and buck-boost converter for further cost saving by removing optocoupler and replacing the transformer by an inductor. The output current capability is 100 mA. The possible operating range is from input range between 20 Vdc and 700 Vdc to output range of 5.0 V or above with 100 mA. Typical efficiency around 65% is obtained in the 12 V buck demo board.

Advantages of the proposed circuits include:

- Comparing to flyback, buck and buck-boost eliminates optocoupler and replaces transformer by an inductor for cost saving.
- Buck and buck-boost offers smaller voltage stress in switches comparing to flyback. It minimizes the switching loss and increases efficiency.
- NCP105x can power up itself from the high input voltage with wide range between 20 Vdc and 700 Vdc. It needs no extra supply circuit.
- NCP105x operates at 44, 100, or 136 kHz and accommodates low-cost components such as aluminum electrolytic capacitors and powered-iron core magnetic.
- NCP105x offers frequency jittering for reduced electromagnetic interference (EMI).
- NCP105x offers thermal and short circuit fault protection.
- Simple design as no control-loop compensation is concerned.

The proposed buck and buck-boost converters are very similar to each other. Their major difference is that buck provides a positive output voltage but buck-boost provides a negative output voltage referring to the input ground.

PRINCIPLE OF OPERATION

Figure 1 shows the proposed buck and buck-boost converters. The rectifier circuit, which consists of capacitor C_3 and diode D_3 , is in the front end for AC or DC input voltage. Then, the NCP1052 is self-powered up from the rectified input voltage directly with a V_{CC} capacitor C_2 . When the switch inside the IC is opened, there is a voltage across Drain (D) and Source (S) pins of the IC. If this voltage is greater than 20 V, an internal current source $I_{start} = 6.3$ mA (typ.) inside the IC charges up C_2 and a voltage in C_2 is built up for the operation of the IC. Comparing to the switching frequency, the V_{CC} voltage level is in a lower-frequency 7.5-8.5 V hysteresis loop. This V_{CC} hysteresis loop is for frequency jittering features to minimize EMI and short-circuit fault timing function.

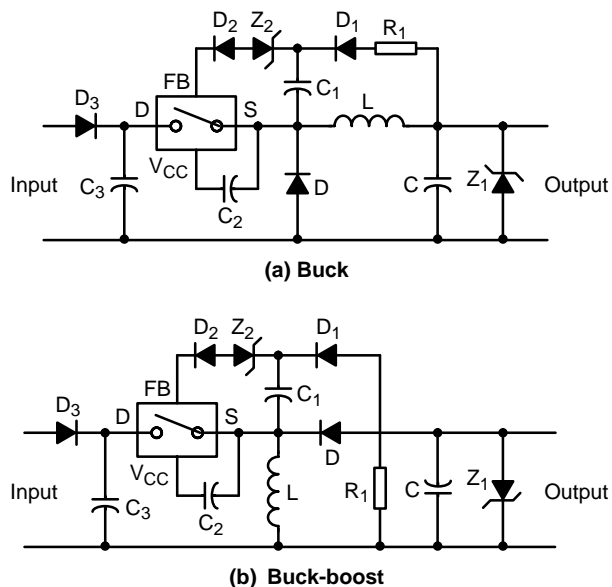

Figure 1. Proposed Circuit Using NCP1052

In Figure 2a it is noted that in the buck topology the input voltage powers up the IC through the path across the inductor L and capacitor C. This charging path passes

through the output and a low-frequency ripple will be found in the output voltage. Hence, the value of C_2 is needed to be small enough to increase this charging frequency $f_{V_{CC}}$ in order to reduce output voltage ripple because some efficiency is lost due to this low-frequency ripple.

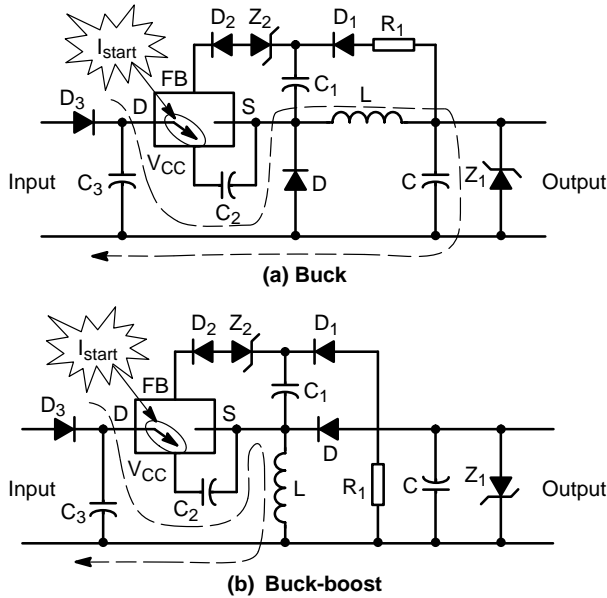

Figure 2. Charging Current of C_2

In Figure 2b it is noted that in the buck-boost topology the charging current path is blocked by diode D and hence the charging of C_2 does not affect the output voltage directly. However, it still affects the output voltage indirectly and slightly by adding some low-frequency noise on the inductor. Hence, small value of C_2 is also wanted.

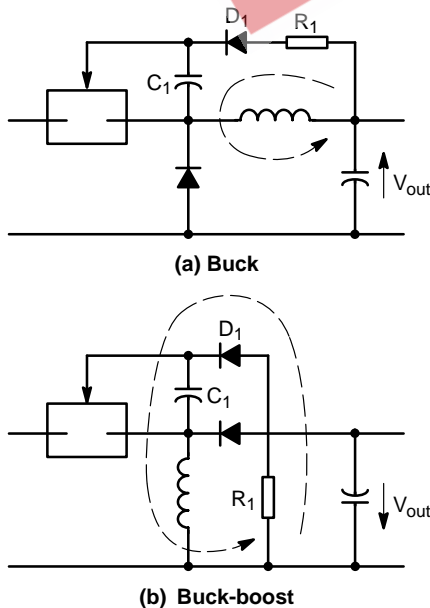

Figure 3. Output Voltage Couples to C_1 with a Charging Current

The function of diode D_1 , capacitor C_1 and resistor R_1 are to transfer the magnitude of output voltage to a voltage across C_1 so that the IC can regulate the output voltage. In Figure 3, when the main switch inside the IC is opened and the diode D is closed. In buck, the potential of the IC reference ground (pin S) becomes almost 0 V in this moment. In buck-boost, the potential of the IC reference ground (pin S) becomes $-V_{out}$ in this moment. The voltage in C_1 will be charged to the output voltage. On the other hand, when main switch is closed and the diode D is opened, diode D_1 is reverse biased by a voltage with magnitude V_{in} and $V_{in}+V_{out}$ respectively. Hence, D_1 does not affect the normal operation of the buck and buck-boost converter.

It is noted that the instantaneous voltage in C_1 can be possibly greater than the output voltage especially when output current or output ripple is too large. It directly affects the load regulation of the circuit since the IC regulates the output voltage based on the voltage in C_1 . In order to solve it, larger values of L and R_1 can help to slow down the charging speed of C_1 . It reduces the maximum instantaneous voltage in C_1 so that output voltage at high output current can be pulled up and a good regulation is made.

Larger value of L can help the load regulation but it usually unwanted because it is bulky. Hence, resistor R_1 is recommended. Larger value of R_1 makes higher output voltage. Hence, it is called as a “pull-up resistor” and it can help to pull up the output voltage slightly.

The voltage in C_1 representing the output voltage is feedback to the feedback (FB) pin of the NCP1052 through a diode D_2 and zener diode Z_2 . When output voltage is too high, there will be a greater-than-50 μA current inserting into the feedback pin of the NCP1052. The NCP1052 will stop switching when it happens. When output voltage is not high enough, the current inserting into the feedback is smaller than 50 μA . The NCP1052 enables switching and power is delivered to the output until the output voltage is too high again.

The purpose of the diode D_2 is to ensure the current is inserting into the feedback pin because the switching of NCP1052 can also be stopped when there is a greater-than-50 μA current sinking from the FB pin. The purpose of the zener diode Z_2 is to set the output voltage threshold. The FB pin of NCP1052 with a condition of 50 μA sourcing current is about 4.3 V. The volt-drop of the diode D_2 is loosely about 0.7 V at 50 μA . Hence, the output voltage can be loosely set as follows:

$$V_{out} = \text{zener} + 4.3 \text{ V} + 0.7 \text{ V} \quad (\text{eq. 1})$$

$$= \text{zener} + 5 \text{ V}$$

According to (1), the possible minimum output voltage of the circuit is 5.0 V when there is no zener diode Z_2 .

If there is no load, the IC will automatically minimize its duty cycle to the minimum value but the output voltage is still possible to be very high because there is no passive component in the circuit try to absorb the energy. As a result,

AND8098/D

output voltage will rise up dramatically and burn the output capacitor eventually. Hence, a zener diode Z_1 or minimum “dummy” load resistor is needed to consume the minimum amount of energy as shown in Figure 1. It is also noted that when R_1 pulls up the output voltage at a given output current condition, the output voltages at lower output current conditions are also pulled up. Hence, the clamping zener diode Z_1 is needed to be with the breakdown voltage as same as the output voltage but it will reduce some of the efficiency at lower output current conditions.

DESIGN CONSIDERATION

Topology

Buck circuit is to step down a voltage. Buck-boost circuit is to step up or down a voltage. The output voltage is inverted. The maximum duty of NCP1052 is typically 77%.

Because of burst-mode control, the effective maximum duty is lower and said to be 70% roughly. When a buck converter is in continuous conduction mode (CCM), the input voltage V_{in} and output voltage V_{out} are related by the duty ratio D .

$$\frac{V_{out}}{V_{in}} = D < 0.7 \quad (\text{eq. 2})$$

The relationship in buck-boost is

$$\left| \frac{V_{out}}{V_{in}} \right| = \frac{D}{1-D} < \frac{0.7}{1-0.7} = 2.33 \quad (\text{eq. 3})$$

Another aspect on topology is the output current. The maximum output current is always smaller than the maximum switch current in non-isolated topologies. However, in isolated topologies such as flyback the maximum output current can be increased by a transformer.

Table 1. Summary of Topology Difference Using NCP1052

	Buck	Buck-boost	Flyback
Output voltage	$< 0.7 V_{in}$	Negative & $< 2.33 V_{in}$	Depending on transformer ratio
Output current	$< 300 \text{ mA}$	$\ll 300 \text{ mA}$, output current is only a portion of the inductor current	$< 10 \text{ W}$. It depends on operating condition and audible noise level
Input voltage	$< 700 \text{ V}$	$< 700 - V_{out} \text{ V}$ $< 700 \text{ V}$	$\ll 700 \text{ V}$. It depends on transformer ratio
Operating mode in nominal condition	Continuous	Continuous	Discontinuous
Standby ability on V_{CC} charging current	Bad. The current flows through output even if there is no load	Good. The current passes through inductor only	Good. The current passes through primary winding only
Transformer / Auxiliary winding	It is only for standby improvement or additional output	It is only for standby improvement or additional output	It is a must for the main output. Additional auxiliary winding can improve standby performance
Isolation	No	No	Yes. Opto coupler can be eliminated if isolation is not needed

Burst-mode Operation

The NCP1052 is with a burst-mode control method. It means the MOSFET can be completely off for one or more switching cycles. The output voltage is regulated by the overall duration of dead time or non-dead time over a number of switching cycles. This feature offers advantages on saving energy in standby condition since it can reduce the effective duty cycle dramatically. In flyback topology, the circuit is mainly designed for discontinuous conduction mode (DCM) in which the inductor current reaches zero in every switching cycle. The DCM burst-mode waveform can be represented in Figure 4. It is similar to the pulse-width modulation (PWM) one.

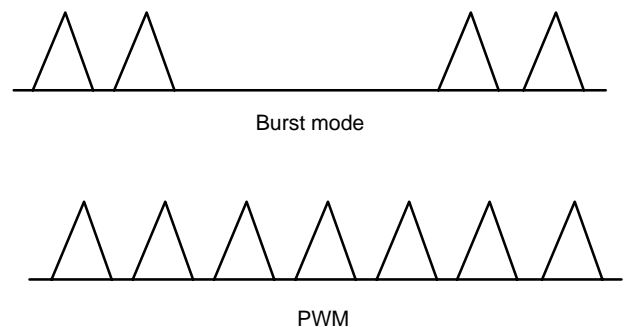

Figure 4. DCM Inductor Currents in Burst Mode and PWM Control

AND8098/D

In non-isolated topologies such as buck or buck-boost, the circuits are mainly designed for CCM. The CCM burst-mode waveform is different to the PWM waveform in Figure 5. Because of this characteristic, burst mode requires a higher peak value of the inductor current in order to have the same level of averaged inductor current (or output current).

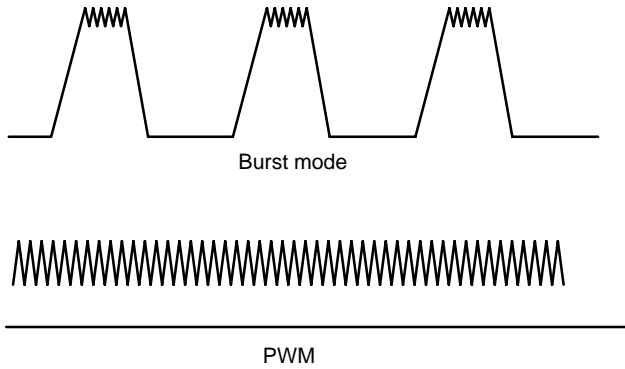

Figure 5. CCM Inductor Currents in Burst Mode and traditional PWM Control

As shown in Figure 4 and 5 burst-mode control produces low-frequency waveform comparing to the switching frequency. Part of the power loss in this low frequency becomes audible noise. Therefore, burst-mode control is not suitable for high power applications such as more than 20 W.

V_{CC} Capacitor

The V_{CC} capacitor C₂ is the key component to make the circuit operate in normal mode or fault mode. The device recognizes a fault condition when there is no feedback current in the FB pin during the time from V_{CC} = 8.5 V to 7.5 V. The V_{CC} capacitor directly affects this time duration.

In normal mode, the V_{CC} follows a 8.5 V-7.5 V-8.5 V hysteresis loop. When the circuit is in fault mode, the V_{CC} follows a 8.5 V-7.5 V-4.5 V-8.5 V hysteresis loop. The device keeps its MOSFET opened except for the time from V_{CC} = 8.5 V to 7.5 V and delivers a little amount of power to the output in fault mode.

A common and extreme case to enter fault condition is the startup. The MOSFET begins switching at the V_{CC} is firstly charged to 8.5 V and hence output voltage rises. The output voltage needs some time to build up the output voltage from 0 V to a desired value. When the desired level is reached, a feedback current flows into the device to stop its switching. If the feedback current is determined before V_{CC} reaches 7.5V, the circuit will remain in normal mode. Otherwise, the circuit will enter the fault mode and cannot provide the output voltage at its desired level. Therefore, the V_{CC} capacitor is needed to be big enough to ensure sufficient time for V_{CC} going from 8.5 V to 7.5 V to sample feedback current in startup.

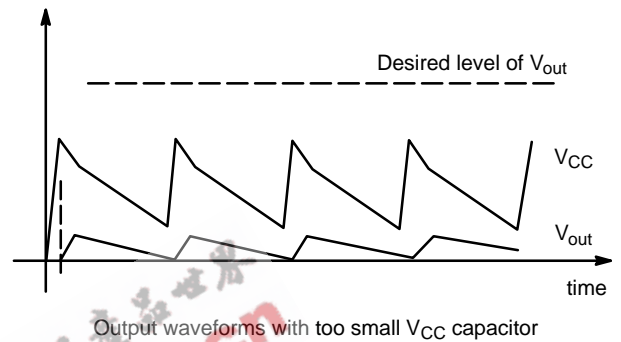
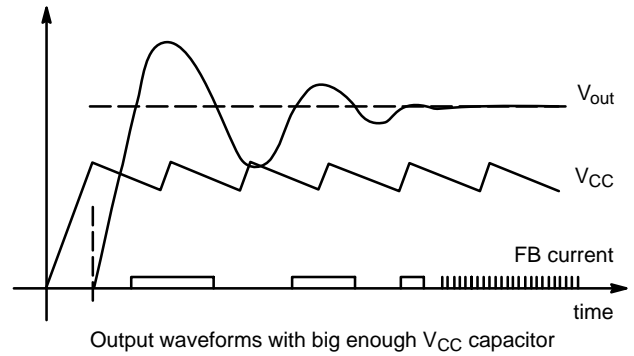

Figure 6. Startup Scenarios of the Circuits with Big Enough or Too Small V_{CC} Capacitor

Practically, the NCP1052 consumes approximately 0.5 mA in normal operation. The concerned fault sampling time for feedback signal is from 8.5 V to 7.5V. Hence,

$$C = I \frac{dt}{dV} = \frac{0.5 \times 10^{-3}}{1} \cdot \text{sampling time} \quad (\text{eq. 4})$$

$$= 0.5 \times 10^{-3} \cdot \text{sampling time}$$

For example, if sampling time or startup transient is designed to be 20 ms, 10 μF V_{CC} capacitor is needed.

Inductor

The 300 mA current limit in the NCP1052 is measured with a condition that the di/dt reaches 300 mA in 4 μs. When the buck or buck-boost circuit is designed for universal ac input voltage (85 to 265 Vac), the rectified input voltage will be possibly as high as 375 Vdc. In order to keep the 4 μs condition, the inductance value will be 5 mH by (5) and (6).

For buck,

$$\frac{di}{dt} = \frac{V_{in} - V_{out}}{L} \approx \frac{V_{in}}{L} \quad (\text{eq. 5})$$

For buck-boost,

$$\frac{di}{dt} = \frac{V_{in}}{L} \quad (\text{eq. 6})$$

The 5 mH is practically too high and hence not very practical. Therefore, the inductor is basically selected by market available inductor models which is with a normally smaller inductance (but not too small). It must have enough saturation current level (>300 mA). If inductance is too

AND8098/D

small, the di/dt becomes too high and the NCP1052 will have a very high current limit effectively because there is a propagation delay (typically 135 ns) to turn off the switch.

The current flowing through the inductor L includes three parts. First, there is a V_{CC} charging current I_{start} in Figure 2. It happens when V_{CC} needs charging. Its magnitude is 6.3 mA. It is noted that the V_{CC} discharging current does not flow through the inductor. Second, it is the main inductor current to deliver the output current. It is noted that the peak of burst-mode inductor current is higher than PWM one as in Figure 5 for the same level of averaged inductor current (or output current). Finally, there is a current flowing through diode D_1 to charge up C_1 . It also flows through the inductor as shown in Figure 3. Its magnitude is a greater-than-50 μA current and practically it is about 1 mA. Hence, the saturation current of the inductor L is needed to be bigger than their sum.

Another consideration on the inductor is the low-pass filtering capability for the V_{CC} hysteresis low frequency (and the 50/ 60 Hz rectified AC line voltage ripple). As shown in Figure 2, there is a low-frequency charging current with magnitude 6.3 mA flowing through the inductor and causes low-frequency ripple in the output voltage. A higher value of the inductance can help to reduce the output ripple. It is noted that when the output power is higher, the startup time becomes longer. It needs bigger V_{CC} capacitor and makes lower V_{CC} charging frequency. As a result, a bigger inductance is needed.

The last consideration is the effect of load regulation. Large inductor can limit the inrush current flowing into capacitor C_1 as shown in Figure 3. High inrush current is not desirable because it can make the C_1 voltage higher than the output voltage. It makes load regulation poor. If there is no pull-up resistor R_1 , inductor value L is chosen to be as large as possible, say 2 mH.

Output Capacitor

Because of the burst-mode characteristic and the low-frequency V_{CC} charging current, the output ripple is larger than those in PWM. Hence, a relatively bigger output capacitor is needed to keep output ripple small. However, big output capacitor needs a long time to build up the output voltage initially and hence the circuit may enter into fault mode in the startup in Figure 6.

Buffering Capacitor

Buffering capacitor C_2 is to provide a greater-than-50 μA to the feedback pin of NCP1052. It is relatively much smaller than the output capacitor because the current consumption in this capacitor is much smaller and the output voltage cannot copy to this buffering capacitor if the buffering capacitor voltage is higher than the output voltage.

Diodes

D and D_1 are recommended to be the same part for compatibility in speed and voltage drop. It helps the voltage in the capacitor C_1 to be similar to the output voltage. The reverse blocking voltage of D and D_1 is needed to be large enough to withstand the input voltage in buck and input voltage plus output voltage in buck-boost respectively.

D_2 is not a critical component. Its function is to make sure that feedback current is only in one direction. The accuracy of its voltage drop used in (1) is not important since the 4.3V reference voltage in the NCP1052 is loosely set.

Zener Diodes

Z_1 is to clamp the output voltage when there is light load or no load. Hence, the accuracy of Z_1 helps the regulation accuracy in the light load or no load condition. It is also the main component to consume energy when the circuit is in no load condition. The output voltage is clamped and hence the output capacitor is protected.

Z_2 and R_1 are to set the output voltage at the nominal load current. Hence, their accuracy affects the regulation accuracy at the nominal load condition. The relationship between zener voltage and output voltage is shown in (1). Higher value of R_1 helps to pull up the output voltage higher by reducing the charging rate of the buffering capacitor C_1 .

Standby Condition

The standby ability of the proposed buck converter is not good. It is because there is a V_{CC} charging current I_{start} flows through the output capacitor in Figure 2(a). This charging current is a low-frequency pulsating signal. As a result, the voltage in the output capacitor continuously rises up by the charging current pulses. In order to prevent over voltage in the output capacitor, the zener Z_1 absorbs the charging current. It consumes main portion of energy in standby.

AND8098/D

The proposed buck-boost is better in term of the standby ability. It is because the V_{CC} charging current in Figure 2(b) only passes through the inductor. The charging current pulses become an averaged energy stored in the inductor and consume smaller amount of power comparing to the buck case.

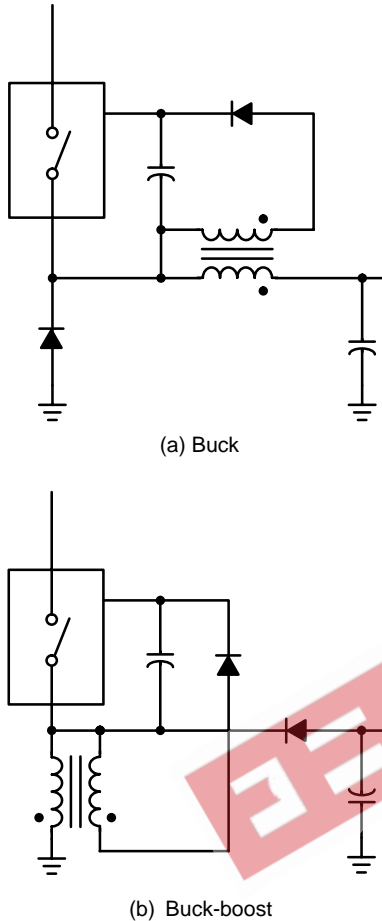

Figure 7. Auxiliary Winding to improve standby Ability

The auxiliary winding to supply the V_{CC} voltage in Figure 7 is a method to improve the standby ability. The auxiliary winding keeps the V_{CC} voltage above 7.5 V and disable the V_{CC} charging current and hence its standby loss. The auxiliary winding is coupled from the inductor L with polarity same as the regulated output voltage. The V_{CC} voltage in the auxiliary winding is designed to be between the normal V_{CC} limits of 7.5 and 8.5 V typically. The frequency jittering feature loses when the V_{CC} voltage is fixed. When output is shorted, there will be no voltage coming from the auxiliary winding and the circuit will enter

fault mode with the 4.5 V-8.5 V-7.5 V-4.5 V hysteresis loop.

Another method to supply the V_{CC} voltage is coupling capacitor technique in Figure 8. The output voltage is coupled to the inserted capacitor when the diodes are closed. The voltage drop of the diodes compensate each other. Hence, the diode voltage drop effect can be neglected. The NCP1052 needs a nominal V_{CC} voltage of 8V. The inserted resistor consumes some voltage from the output voltage V_{out} to make a 8V to the V_{CC} pin. Based on the 0.5mA typical current consumption of V_{CC} pin. The inserted resistance value is $(V_{out} - 8) / 0.5 \text{ k}\Omega$.

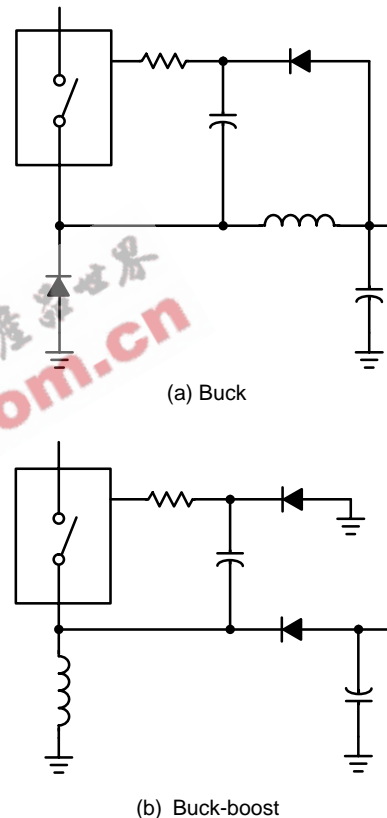

Figure 8. Coupling Capacitor Technique to Improve Standby Ability

Temperature Rise

The NCP1052 is a very compact package with the control circuit and high-voltage power switch. Its typical on resistance is 22 Ω . Temperature rise exists. It is recommended to design the PCB board with a large copper area next to the device as a heatsink. This heatsink decreases

AND8098/D

the temperature rise and reduces the on resistance. Finally, the efficiency of the circuit is benefited.

EXAMPLES

12 V / 100 mA NCP1052 Buck Demo Board

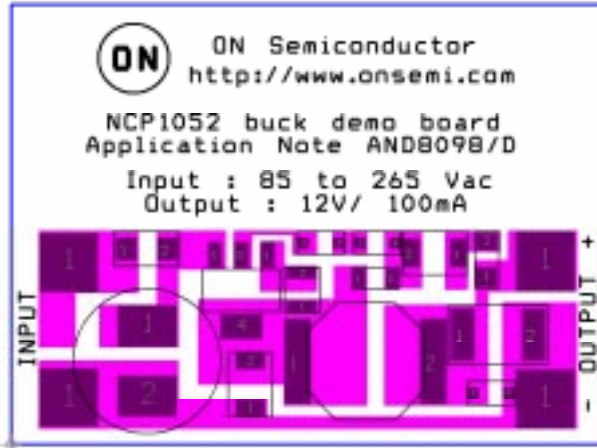

Figure 9. Layout of the Demo Board

As shown in Figure 9, a 2 inch by 1.5 inch small surface-mount demo board of 12 V / 100 mA buck is presented. The design is made on a single-sided board. The bill of material is shown in Table 2. The component symbols are those in Figure 1. In order to have sufficient startup ability, the V_{CC} capacitor is 6.8 μ F which gives a 3.4 ms fault sampling time. Because of this feature, the circuit enters fault mode when output current exceeds 200mA after startup as shown in Figure 10(b). The efficiency of the circuit is typically 65% at 100 mA.

Table 2. Bill of Material of Buck Demo Board

	Part No	Description	Manufacturer
IC	NCP1052ST136	Switching Regulator	ON Semiconductor
D, D ₁	MURS160T3	1A 600V ultrafast	ON Semiconductor
D ₂	MMSD914T1	General diode	ON Semiconductor
D ₃	MRA4005T1	1A 600V standard recovery	ON Semiconductor
Z ₁	MMSZ12T1	12V 5% zener	ON Semiconductor
Z ₂	MMSZ6V8T1	6.8V 5% zener	ON Semiconductor
R ₁	CRCW08052001FRT1	2 k Ω	Vishay
C	594D227X9016R2T	220 μ F, 16 V, tantalum	Vishay
C ₁	VJ1206Y224KXXAT	0.22 μ F, 25 V, ceramic	Vishay
C ₂	595D685X9016A2T	6.8 μ F, 16V, tantalum	Vishay
C ₃	400WA10M12.5X16	400V 10 μ F	Rubycon
L	UP2B-681	680 μ H	Cooper

AND8098/D

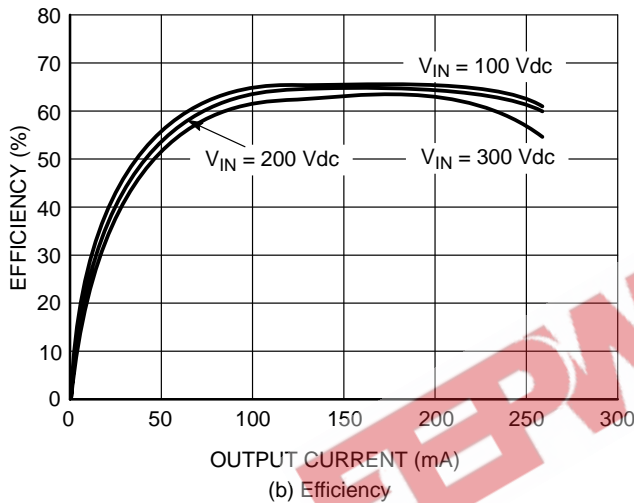
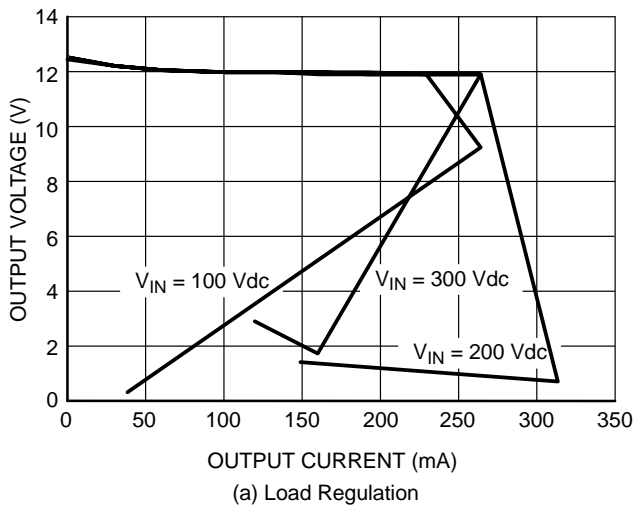

Figure 10. 12V / 100mA Buck Performance

Dual Output Buck-boost with Increased Output Current Capability

Replacing NCP1052 by NCP1055, which is with a current limit of 680 mA, the output current capability is increased. Larger value of inductor L is selected for high current. On the other hand, the current consumption of NCP1055 is higher than NCP1052 and the startup transient time is longer in a higher power application. Hence, the V_{CC} capacitor is increased. When the V_{CC} capacitor increased, its charging frequency is decreased. Output capacitor is also needed to be increased to reduce this lower-frequency charging current/ripple.

In addition, by adding one more auxiliary winding to the inductor a secondary output is made. A typical example is shown in Figure 11. In higher output current application, the load regulation is the major problem. The 5.1k Ω resistor plays an important role for the load regulation. The primary output voltage is higher than the secondary because it can increase the output current ability by stepping up the current in the transformer. The line regulation is shown in Figure 12 when the output currents are constant.

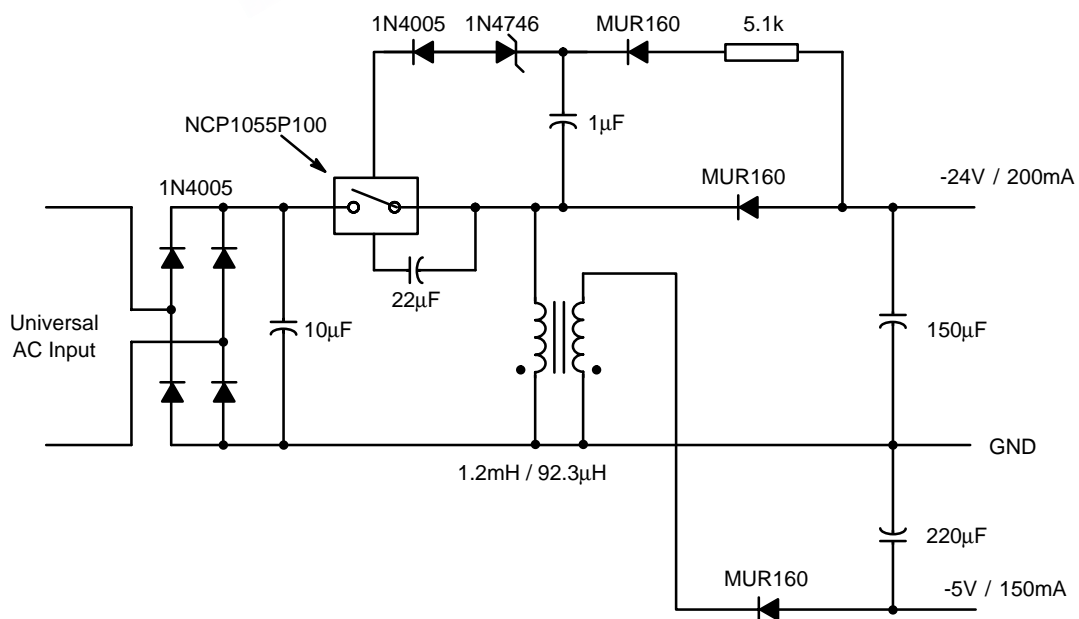

Figure 11. Dual Output Buck-boost

AND8098/D

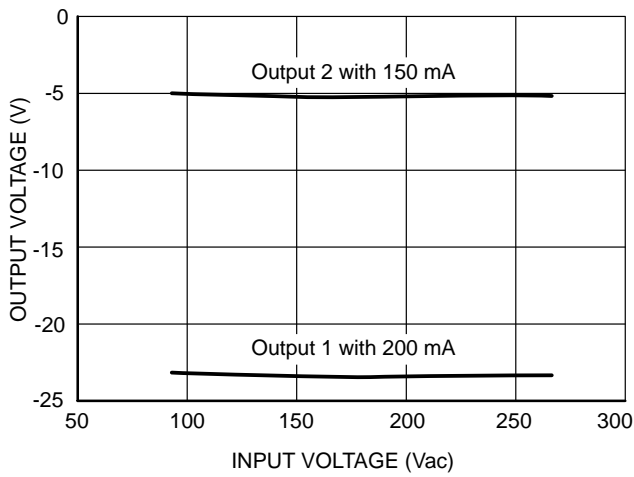

Figure 12. Line Regulation of the Dual Output Buck-boost

CONCLUSION

100 mA high-voltage low-cost buck and buck-boost circuits using NCP1052 are presented. These circuits are designed for cost-saving non-isolated application so that optocoupler and transformer are saved. The possible input voltage range is from 20 Vdc to 700 Vdc so that it is suitable for general AC/DC and DC/DC applications with positive or negative output voltages. It is noted that the standby ability of the circuits is not good because of the V_{CC} capacitor charging current. However, it can be improved by adding an auxiliary winding to the V_{CC} . The design consideration of each component in the circuits is explained. By replacing the NCP1052 with NCP1055, the output current can be increased. By adding an auxiliary winding, multi-output can be obtained. A 12 V / 100 mA demo board is presented with typical 65% efficiency.

EEPW 电子产品世界 .com.cn

AND8098/D

EEPW 电子產品世界
.com.cn

ON Semiconductor and  are registered trademarks of Semiconductor Components Industries, LLC (SCILLC). SCILLC reserves the right to make changes without further notice to any products herein. SCILLC makes no warranty, representation or guarantee regarding the suitability of its products for any particular purpose, nor does SCILLC assume any liability arising out of the application or use of any product or circuit, and specifically disclaims any and all liability, including without limitation special, consequential or incidental damages. "Typical" parameters which may be provided in SCILLC data sheets and/or specifications can and do vary in different applications and actual performance may vary over time. All operating parameters, including "Typicals" must be validated for each customer application by customer's technical experts. SCILLC does not convey any license under its patent rights nor the rights of others. SCILLC products are not designed, intended, or authorized for use as components in systems intended for surgical implant into the body, or other applications intended to support or sustain life, or for any other application in which the failure of the SCILLC product could create a situation where personal injury or death may occur. Should Buyer purchase or use SCILLC products for any such unintended or unauthorized application, Buyer shall indemnify and hold SCILLC and its officers, employees, subsidiaries, affiliates, and distributors harmless against all claims, costs, damages, and expenses, and reasonable attorney fees arising out of, directly or indirectly, any claim of personal injury or death associated with such unintended or unauthorized use, even if such claim alleges that SCILLC was negligent regarding the design or manufacture of the part. SCILLC is an Equal Opportunity/Affirmative Action Employer.

PUBLICATION ORDERING INFORMATION

Literature Fulfillment:

Literature Distribution Center for ON Semiconductor
P.O. Box 5163, Denver, Colorado 80217 USA
Phone: 303-675-2175 or 800-344-3860 Toll Free USA/Canada
Fax: 303-675-2176 or 800-344-3867 Toll Free USA/Canada
Email: ONlit@hibbertco.com

N. American Technical Support: 800-282-9855 Toll Free USA/Canada

JAPAN: ON Semiconductor, Japan Customer Focus Center
2-9-1 Kamimeguro, Meguro-ku, Tokyo, Japan 153-0051
Phone: 81-3-5773-3850

ON Semiconductor Website: <http://onsemi.com>

For additional information, please contact your local
Sales Representative.