

TOSHIBA CMOS DIGITAL INTEGRATED CIRCUIT SILICON MONOLITHIC

TC4030BP, TC4030BF, TC4030BFN

TC4030B QUAD EXCLUSIVE-OR GATE

TC4030B contains four circuits of exclusive OR gates. Since the buffers of two stage inverters are provided for all the outputs, the input/output voltage characteristic has been improved and the noise immunity has been also improved. And increase of transmission time due to load capacity increase is kept minimum.

Wide variety of applicaitons are offered, such as digital comparators and parity circuits.

(Note) The JEDEC SOP (FN) is not available in Japan.

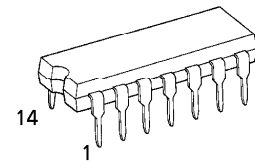

P (DIP14-P-300-2.54)
Weight : 0.96g (Typ.)

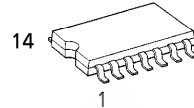

F (SOP14-P-300-1.27)
Weight : 0.18g (Typ.)

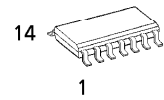

FN (SOL14-P-150-1.27)
Weight : 0.12g (Typ.)

MAXIMUM RATINGS

CHARACTERISTIC	SYMBOL	RATING	UNIT
DC Supply Voltage	V_{DD}	$V_{SS} - 0.5 \sim V_{SS} + 20$	V
Input Voltage	V_{IN}	$V_{SS} - 0.5 \sim V_{DD} + 0.5$	V
Output Voltage	V_{OUT}	$V_{SS} - 0.5 \sim V_{DD} + 0.5$	V
DC Input Current	I_{IN}	± 10	mA
Power Dissipation	P_D	300 (DIP) / 180 (SOIC)	mW
Operating Temperature Range	T_{opr}	-40~85	°C
Storage Temperature Range	T_{stg}	-65~150	°C

PIN ASSIGNMENT

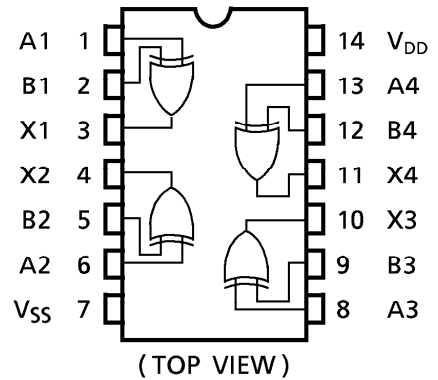

CIRCUIT DIAGRAM

1/4 TC4030B

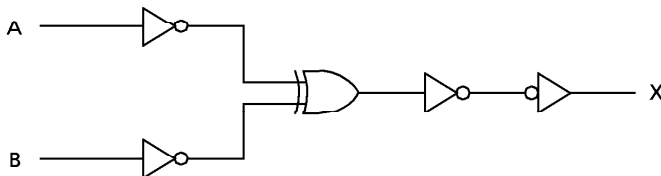

TRUTH TABLE

INPUTS		OUTPUT
A	B	X
L	L	L
L	H	H
H	L	H
H	H	L

961001EBA2

● TOSHIBA is continually working to improve the quality and the reliability of its products. Nevertheless, semiconductor devices in general can malfunction or fail due to their inherent electrical sensitivity and vulnerability to physical stress. It is the responsibility of the buyer, when utilizing TOSHIBA products, to observe standards of safety, and to avoid situations in which a malfunction or failure of a TOSHIBA product could cause loss of human life, bodily injury or damage to property. In developing your designs, please ensure that TOSHIBA products are used within specified operating ranges as set forth in the most recent products specifications. Also, please keep in mind the precautions and conditions set forth in the TOSHIBA Semiconductor Reliability Handbook.

RECOMMENDED OPERATING CONDITIONS ($V_{SS} = 0V$)

CHARACTERISTIC	SYMBOL	TEST CONDITION	MIN.	TYP.	MAX.	UNIT
DC Supply Voltage	V_{DD}		3	—	18	V
Input Voltage	V_{IN}		0	—	V_{DD}	V

STATIC ELECTRICAL CHARACTERISTICS ($V_{SS} = 0V$)

CHARACTERISTIC	SYM-BOL	TEST CONDITION	V_{DD} (V)	-40°C		25°C			85°C		UNIT	
				MIN.	MAX.	MIN.	TYP.	MAX.	MIN.	MAX.		
High-Level Output Voltage	V_{OH}	$ I_{OUT} < 1\mu A$ $V_{IN} = V_{SS}, V_{DD}$	5	4.95	—	4.95	5.00	—	4.95	—	V	
			10	9.95	—	9.95	10.00	—	9.95	—		
			15	14.95	—	14.95	15.00	—	14.95	—		
Low-Level Output Voltage	V_{OL}	$ I_{OUT} < 1\mu A$ $V_{IN} = V_{SS}, V_{DD}$	5	—	0.05	—	0.00	0.05	—	0.05	V	
			10	—	0.05	—	0.00	0.05	—	0.05		
			15	—	0.05	—	0.00	0.05	—	0.05		
Output High Current	I_{OH}	$V_{OH} = 4.6V$ $V_{OH} = 2.5V$ $V_{OH} = 9.5V$ $V_{OH} = 13.5V$ $V_{IN} = V_{SS}, V_{DD}$	5	-0.61	—	-0.51	-1.0	—	-0.42	—	mA	
			5	-2.50	—	-2.10	-4.0	—	-1.70	—		
			10	-1.50	—	-1.30	-2.2	—	-1.10	—		
			15	-4.00	—	-3.40	-9.0	—	-2.80	—		
Output Low Current	I_{OL}	$V_{OL} = 0.4V$ $V_{OL} = 0.5V$ $V_{OL} = 1.5V$ $V_{IN} = V_{SS}, V_{DD}$	5	0.61	—	0.51	1.2	—	0.42	—	mA	
			10	1.50	—	1.30	3.2	—	1.10	—		
			15	4.00	—	3.40	12.0	—	2.80	—		
Input High Voltage	V_{IH}	$V_{OUT} = 0.5V, 4.5V$ $V_{OUT} = 1.0V, 9.0V$ $V_{OUT} = 1.5V, 13.5V$ $ I_{OUT} < 1\mu A$	5	3.5	—	3.5	2.75	—	3.5	—	V	
			10	7.0	—	7.0	5.50	—	7.0	—		
			15	11.0	—	11.0	8.25	—	11.0	—		
Input Low Voltage	V_{IL}	$V_{OUT} = 0.5V, 4.5V$ $V_{OUT} = 1.0V, 9.0V$ $V_{OUT} = 1.5V, 13.5V$ $ I_{OUT} < 1\mu A$	5	—	1.5	—	2.25	1.5	—	1.5	V	
			10	—	3.0	—	4.50	3.0	—	3.0		
			15	—	4.0	—	6.75	4.0	—	4.0		
Input Current	"H" Level	I_{IH}	$V_{IH} = 18V$	18	—	0.1	—	10^{-5}	0.1	—	1.0	μA
	"L" Level	I_{IL}	$V_{IL} = 0V$	18	—	-0.1	—	-10^{-5}	-0.1	—	-1.0	
Quiescent Supply Current	I_{DD}	$V_{IN} = V_{SS}, V_{DD}^*$	5	—	1	—	0.001	1	—	7.5	μA	
			10	—	2	—	0.001	2	—	15.0		
			15	—	4	—	0.002	4	—	30.0		

* All valid input combinations.

961001EBA2'

- The products described in this document are subject to foreign exchange and foreign trade control laws.
- The information contained herein is presented only as a guide for the applications of our products. No responsibility is assumed by TOSHIBA CORPORATION for any infringements of intellectual property or other rights of the third parties which may result from its use. No license is granted by implication or otherwise under any intellectual property or other rights of TOSHIBA CORPORATION or others.
- The information contained herein is subject to change without notice.

DYNAMIC ELECTRICAL CHARACTERISTICS (Ta = 25°C, Vss = 0V, CL = 50pF)

CHARACTERISTIC	SYMBOL	TEST CONDITION	V _{DD} (V)	MIN.	TYP.	MAX.	UNIT
Output Transition Time (Low to High)	t _{TLH}		5	—	70	200	ns
			10	—	35	100	
			15	—	30	80	
Output Transition Time (High to Low)	t _{THL}		5	—	70	200	ns
			10	—	35	100	
			15	—	30	80	
Propagation Delay Time	t _{pLH}		5	—	90	280	ns
	t _{pHL}		10	—	45	130	
			15	—	35	100	
Input Capacitance	C _{IN}			—	5	7.5	pF

CIRCUIT AND WAVEFORM FOR MEASUREMENT OF DYNAMIC CHARACTERISTICS

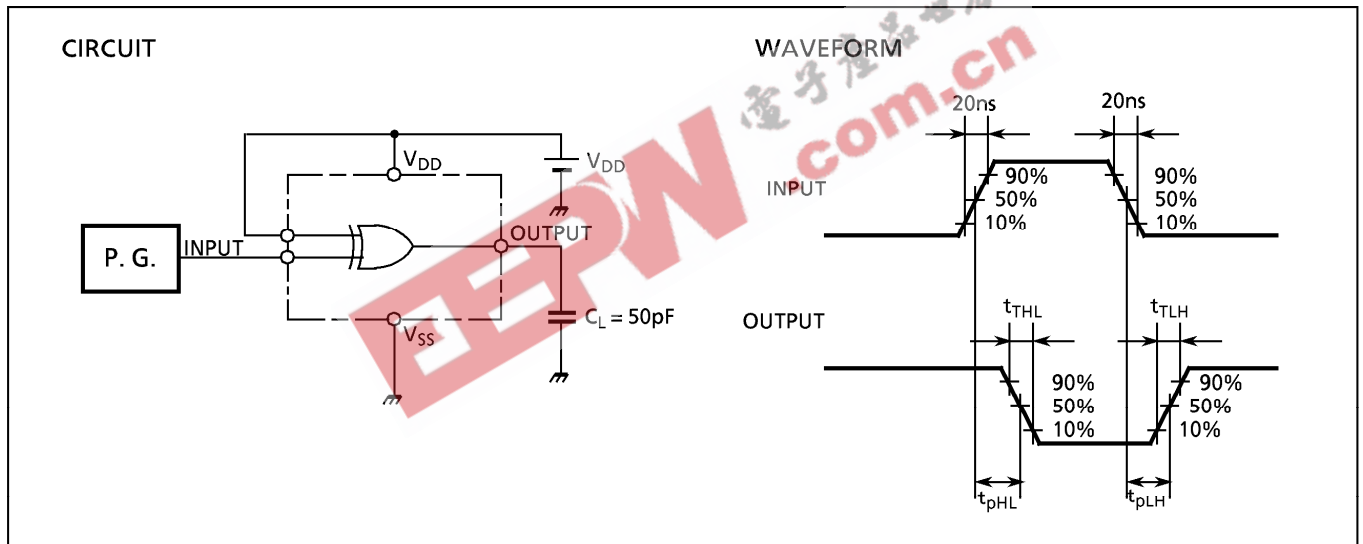

DIP 14PIN OUTLINE DRAWING (DIP14-P-300-2.54)

Unit in mm

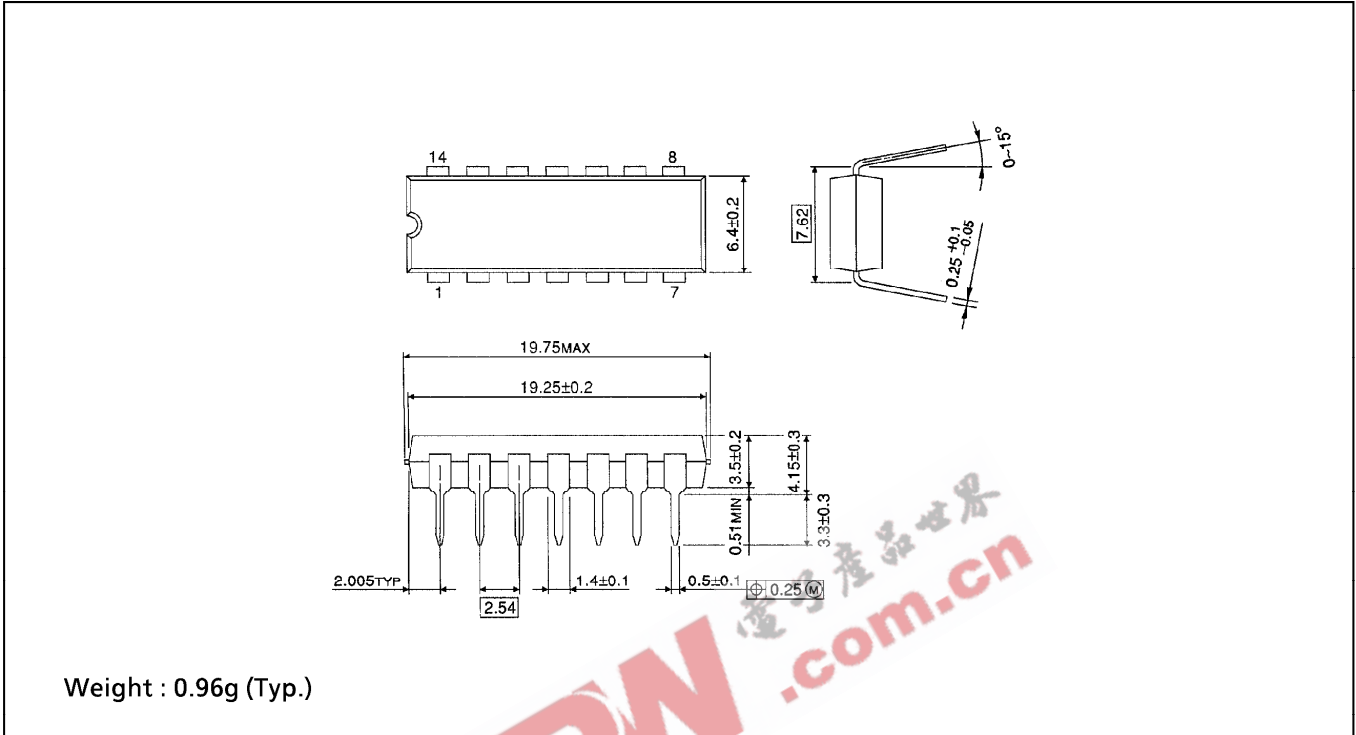

SOP 14PIN (200mil BODY) OUTLINE DRAWING (SOP14-P-300-1.27)

Unit in mm

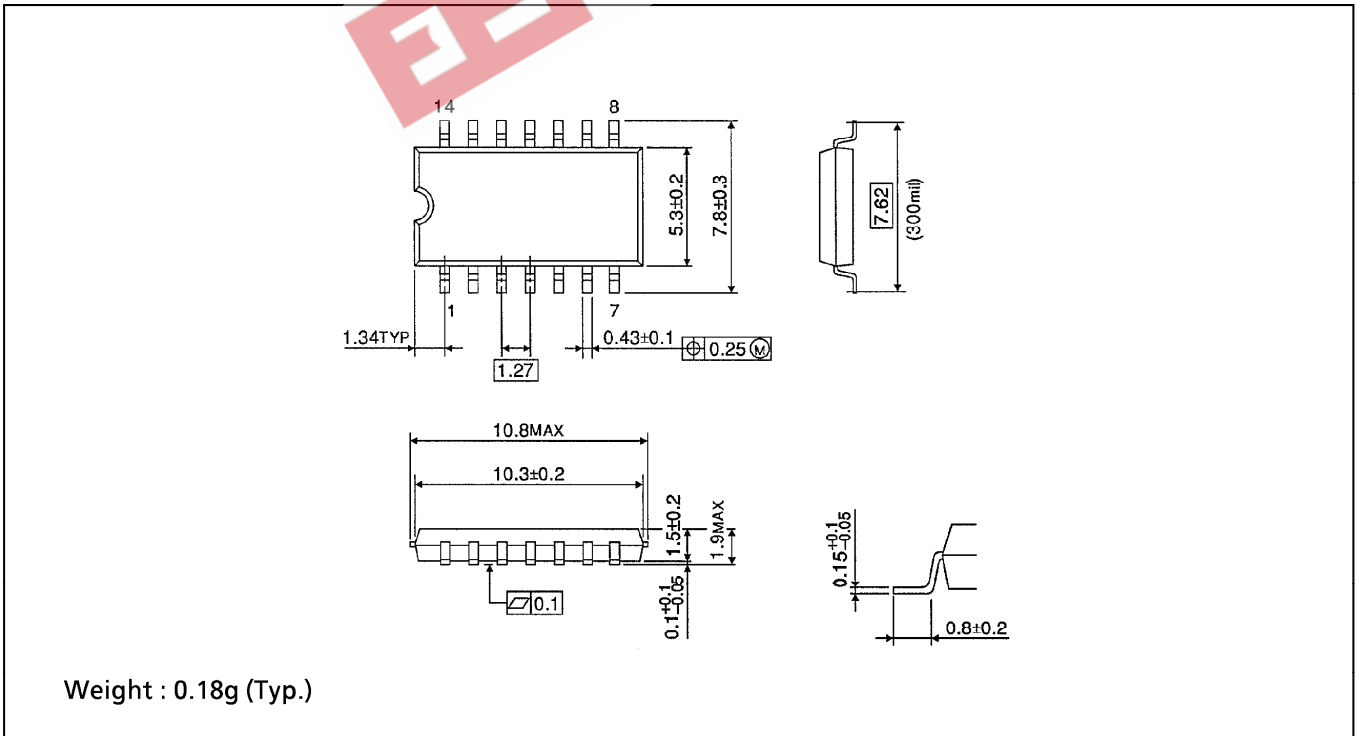

SOP 14PIN (150mil BODY) OUTLINE DRAWING (SOL14-P-150 -1.27)

Unit in mm

(Note) This package is not available in Japan.

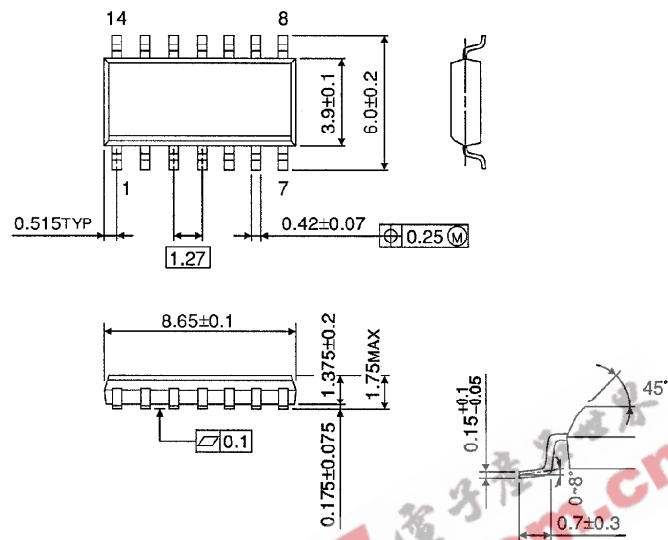

Weight : 0.12g (Typ.)

EEPW.com.cn