

CD4069UBM/CD4069UBC Inverter Circuits

General Description

The CD4069UB consists of six inverter circuits and is manufactured using complementary MOS (CMOS) to achieve wide power supply operating range, low power consumption, high noise immunity, and symmetric controlled rise and fall times.

This device is intended for all general purpose inverter applications where the special characteristics of the MM74C901, MM74C903, MM74C907, and CD4049A Hex Inverter/Bufferers are not required. In those applications requiring larger noise immunity the MM74C14 or MM74C914 Hex Schmitt Trigger is suggested.

All inputs are protected from damage due to static discharge by diode clamps to V_{DD} and V_{SS} .

Features

- Wide supply voltage range 3.0V to 15V
- High noise immunity 0.45 V_{DD} typ.
- Low power TTL compatibility Fan out of 2 driving 74L or 1 driving 74LS
- Equivalent to MM54C04/MM74C04

Schematic and Connection Diagram

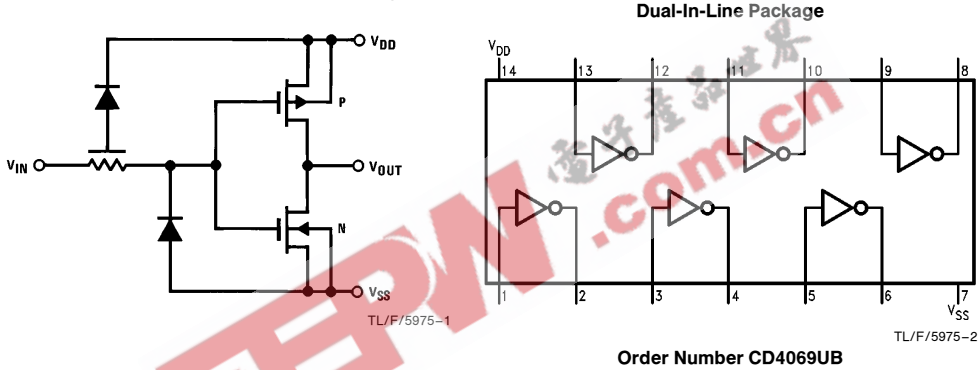

AC Test Circuits and Switching Time Waveforms

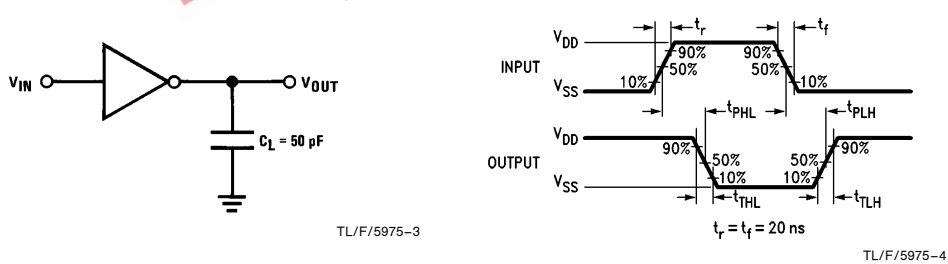

Absolute Maximum Ratings (Notes 1 & 2)

If Military/Aerospace specified devices are required, please contact the National Semiconductor Sales Office/Distributors for availability and specifications.

DC Supply Voltage (V_{DD})	-0.5V to +18 V_{DC}
Input Voltage (V_{IN})	-0.5V to V_{DD} + 0.5 V_{DC}
Storage Temperature Range (T_S)	-65°C to +150°C
Power Dissipation (P_D)	
Dual-In-Line	700 mW
Small Outline	500 mW
Lead Temperature (T_L)	
(Soldering, 10 seconds)	260°C

Recommended Operating Conditions (Note 2)

DC Supply Voltage (V_{DD})	3V to 15 V_{DC}
Input Voltage (V_{IN})	0V to V_{DD} V_{DC}
Operating Temperature Range (T_A)	
CD4069UBM	-55°C to +125°C
CD4069UBC	-40°C to +85°C

DC Electrical Characteristics CD4069UBM (Note 2)

Symbol	Parameter	Conditions	-55°C		+25°C			+125°C		Units
			Min	Max	Min	Typ	Max	Min	Max	
I_{DD}	Quiescent Device Current	$V_{DD} = 5V$, $V_{IN} = V_{DD}$ or V_{SS} $V_{DD} = 10V$, $V_{IN} = V_{DD}$ or V_{SS} $V_{DD} = 15V$, $V_{IN} = V_{DD}$ or V_{SS}		0.25			0.25		7.5	μA
				0.5			0.5		15	μA
				1.0			1.0		30	μA
V_{OL}	Low Level Output Voltage	$ I_O < 1 \mu A$ $V_{DD} = 5V$ $V_{DD} = 10V$ $V_{DD} = 15V$		0.05		0	0.05		0.05	V
				0.05		0	0.05		0.05	V
				0.05		0	0.05		0.05	V
				0.05		0	0.05		0.05	V
V_{OH}	High Level Output Voltage	$ I_O < 1 \mu A$ $V_{DD} = 5V$ $V_{DD} = 10V$ $V_{DD} = 15V$	4.95		4.95	5		4.95		V
			9.95		9.95	10		9.95		V
			14.95		14.95	15		14.95		V
V_{IL}	Low Level Input Voltage	$ I_O < 1 \mu A$ $V_{DD} = 5V, V_O = 4.5V$ $V_{DD} = 10V, V_O = 9V$ $V_{DD} = 15V, V_O = 13.5V$		1.0				1.0	1.0	V
				2.0				2.0	2.0	V
				3.0				3.0	3.0	V
										V
V_{IH}	High Level Input Voltage	$ I_O < 1 \mu A$ $V_{DD} = 5V, V_O = 0.5V$ $V_{DD} = 10V, V_O = 1V$ $V_{DD} = 15V, V_O = 1.5V$	4.0		4.0			4.0		V
			8.0		8.0			8.0		V
			12.0		12.0			12.0		V
										V
I_{OL}	Low Level Output Current (Note 3)	$V_{DD} = 5V, V_O = 0.4V$ $V_{DD} = 10V, V_O = 0.5V$ $V_{DD} = 15V, V_O = 1.5V$	0.64		0.51	0.88		0.36		mA
			1.6		1.3	2.25		0.9		mA
			4.2		3.4	8.8		2.4		mA
I_{OH}	High Level Output Current (Note 3)	$V_{DD} = 5V, V_O = 4.6V$ $V_{DD} = 10V, V_O = 9.5V$ $V_{DD} = 15V, V_O = 13.5V$	-0.64		-0.51	-0.88		-0.36		mA
			-1.6		-1.3	-2.25		-0.9		mA
			-4.2		-3.4	-8.8		-2.4		mA
I_{IN}	Input Current	$V_{DD} = 15V, V_{IN} = 0V$ $V_{DD} = 15V, V_{IN} = 15V$		-0.10		-10^{-5}	-0.10		-1.0	μA
				0.10		10^{-5}	0.10		1.0	μA

Note 1: "Absolute Maximum Ratings" are those values beyond which the safety of the device cannot be guaranteed. They are not meant to imply that the devices should be operated at these limits. The table of "Recommended Operating Conditions" and "Electrical Characteristics" provides conditions for actual device operation.

Note 2: $V_{SS} = 0V$ unless otherwise specified.

Note 3: I_{OH} and I_{OL} are tested one output at a time.

DC Electrical Characteristics CD4069UBC (Note 2)										
Symbol	Parameter	Conditions	−40°C		+25°C			+85°C		Units
			Min	Max	Min	Typ	Max	Min	Max	
I _{DD}	Quiescent Device Current	V _{DD} = 5V, V _{IN} = V _{DD} or V _{SS}		1.0			1.0		7.5	μA
		V _{DD} = 10V, V _{IN} = V _{DD} or V _{SS}		2.0		2.0		15	μA	
		V _{DD} = 15V, V _{IN} = V _{DD} or V _{SS}		4.0		4.0		30	μA	
V _{OL}	Low Level Output Voltage	I _O < 1 μA V _{DD} = 5V		0.05		0	0.05		0.05	V
		V _{DD} = 10V		0.05		0	0.05		0.05	V
		V _{DD} = 15V		0.05		0	0.05		0.05	V
V _{OH}	High Level Output Voltage	I _O < 1 μA V _{DD} = 5V	4.95		4.95			4.95		V
		V _{DD} = 10V	9.95		9.95			9.95		V
		V _{DD} = 15V	14.95		14.95			14.95		V
V _{IL}	Low Level Input Voltage	I _O < 1 μA V _{DD} = 5V, V _O = 4.5V		1.0			1.0		1.0	V
		V _{DD} = 10V, V _O = 9V		2.0			2.0		2.0	V
		V _{DD} = 15V, V _O = 13.5V		3.0			3.0		3.0	V
V _{IH}	High Level Input Voltage	I _O < 1 μA V _{DD} = 5V, V _O = 0.5V	4.0		4.0			4.0		V
		V _{DD} = 10V, V _O = 1V	8.0		8.0			8.0		V
		V _{DD} = 15V, V _O = 1.5V	12.0		12.0			12.0		V
I _{OL}	Low Level Output Current (Note 3)	V _{DD} = 5V, V _O = 0.4V	0.52		0.44	0.88		0.36		mA
		V _{DD} = 10V, V _O = 0.5V	1.3		1.1	2.25		0.9		mA
		V _{DD} = 15V, V _O = 1.5V	3.6		3.0	8.8		2.4		mA
I _{OH}	High Level Output Current (Note 3)	V _{DD} = 5V, V _O = 4.6V	−0.52		−0.44	−0.88		−0.36		mA
		V _{DD} = 10V, V _O = 9.5V	−1.3		−1.1	−2.25		−0.9		mA
		V _{DD} = 15V, V _O = 13.5V	−3.6		−3.0	−8.8		−2.4		mA
I _{IN}	Input Current	V _{DD} = 15V, V _{IN} = 0V		−0.30		−10 ^{−5}	−0.30		−1.0	μA
		V _{DD} = 15V, V _{IN} = 15V		0.30		10 ^{−5}	0.30		1.0	μA

AC Electrical Characteristics*						
T _A = 25°C, C _L = 50 pF, R _L = 200 kΩ, t _r and t _f ≤ 20 ns, unless otherwise specified						
Symbol	Parameter	Conditions	Min	Typ	Max	Units
t _{PHL} or t _{PLH}	Propagation Delay Time from Input to Output	V _{DD} = 5V		50	90	ns
		V _{DD} = 10V		30	60	ns
		V _{DD} = 15V		25	50	ns
t _{THL} or t _{TLH}	Transition Time	V _{DD} = 5V		80	150	ns
		V _{DD} = 10V		50	100	ns
		V _{DD} = 15V		40	80	ns
C _{IN}	Average Input Capacitance	Any Gate		6	15	pF
C _{PD}	Power Dissipation Capacitance	Any Gate (Note 4)		12		pF

*AC Parameters are guaranteed by DC correlated testing.

Note 1: "Absolute Maximum Ratings" are those values beyond which the safety of the device cannot be guaranteed. They are not meant to imply that the devices should be operated at these limits. The table of "Recommended Operating Conditions" and "Electrical Characteristics" provides conditions for actual device operation.

Note 2: V_{SS} = 0V unless otherwise specified.

Note 3: I_{OH} and I_{OL} are tested one output at a time.

Note 4: C_{PD} determines the no load AC power consumption of any CMOS device. For complete explanation, see 54C/74C Family Characteristics application note—AN-90.

Typical Performance Characteristics

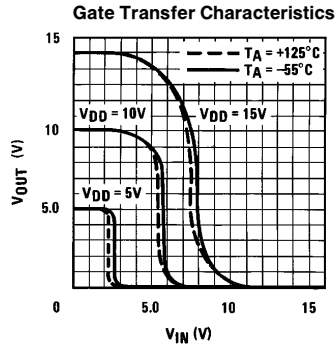

TL/F/5975-5

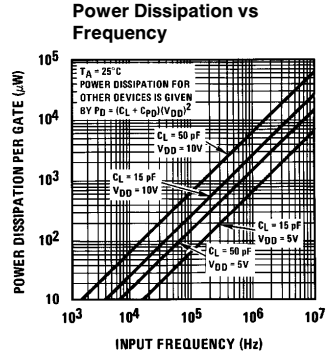

TL/F/5975-6

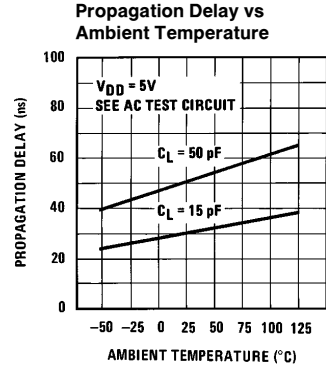

TL/F/5975-7

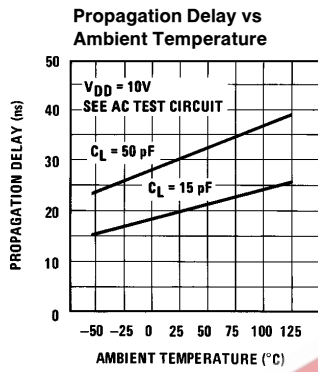

TL/F/5975-8

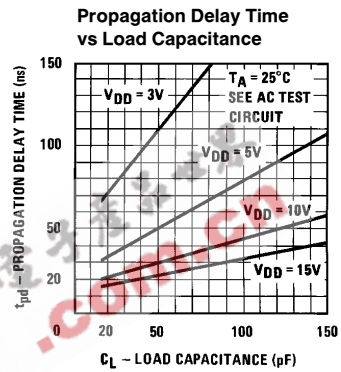

TL/F/5975-9

Physical Dimensions inches (millimeters)

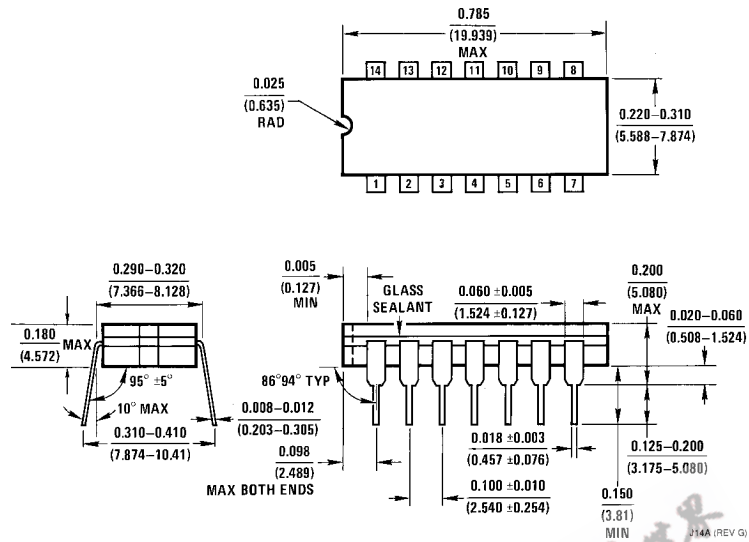

Ceramic Dual-In-Line Package (J)
Order Number CD4069UBMJ or CD4069UBCJ
NS Package Number J14A

EPW.com.cn

Physical Dimensions inches (millimeters) (Continued)

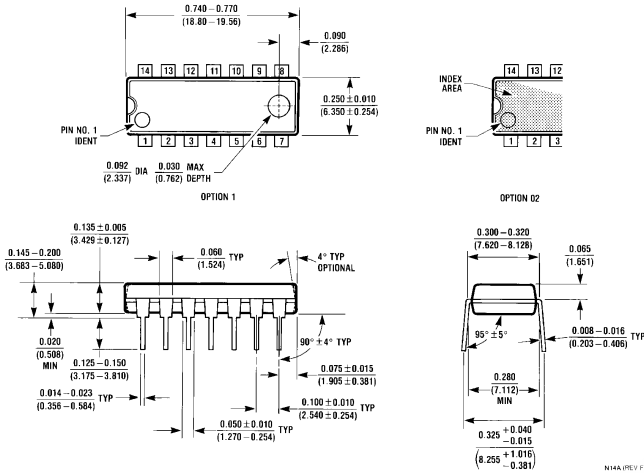

Molded Dual-In-Line Package (N)
Order Number CD4069UBMN or CD4069UBCN
NS Package Number N14A



LIFE SUPPORT POLICY

NATIONAL'S PRODUCTS ARE NOT AUTHORIZED FOR USE AS CRITICAL COMPONENTS IN LIFE SUPPORT DEVICES OR SYSTEMS WITHOUT THE EXPRESS WRITTEN APPROVAL OF THE PRESIDENT OF NATIONAL SEMICONDUCTOR CORPORATION. As used herein:

1. Life support devices or systems are devices or systems which, (a) are intended for surgical implant into the body, or (b) support or sustain life, and whose failure to perform, when properly used in accordance with instructions for use provided in the labeling, can be reasonably expected to result in a significant injury to the user.
2. A critical component is any component of a life support device or system whose failure to perform can be reasonably expected to cause the failure of the life support device or system, or to affect its safety or effectiveness.



National Semiconductor Corporation
 1111 West Bardin Road
 Arlington, TX 76017
 Tel: 1(800) 272-9959
 Fax: 1(800) 737-7018

National Semiconductor Europe
 Fax: (+49) 0-180-530 85 86
 Email: cnjwge@levm2.nsc.com
 Deutsch Tel: (+49) 0-180-530 85 85
 English Tel: (+49) 0-180-532 78 32
 Français Tel: (+49) 0-180-532 93 58
 Italiano Tel: (+49) 0-180-534 16 80

National Semiconductor Hong Kong Ltd.
 13th Floor, Straight Block,
 Ocean Centre, 5 Canton Rd.
 Tsimshatsui, Kowloon
 Hong Kong
 Tel: (852) 2737-1600
 Fax: (852) 2736-9960

National Semiconductor Japan Ltd.
 Tel: 81-043-299-2309
 Fax: 81-043-299-2408

National does not assume any responsibility for use of any circuitry described, no circuit patent licenses are implied and National reserves the right at any time without notice to change said circuitry and specifications.