

Quad exclusive OR gate

BU4030B / BU4030BF
BU4070B / BU4070BF

The BU4030B / F and BU4070B / F are exclusive OR gates.

Four circuits are contained on a single chip. An inverter-based buffer is added to the gate output for an enhanced I / O voltage characteristic, and the load capacitance has been increased to minimize fluctuation in the propagation time.

In addition, these products feature low power consumption and a high noise margin.

These can also be used in digital comparators and parity circuit applications.

●Features

- 1) Low power dissipation.
- 2) Wide range of operating power supply voltages.
- 3) High input impedance.
- 4) High fan-out.
- 5) Direct drive of 2 L-TTL inputs and 1 LS-TTL input.

●Absolute maximum ratings ($V_{SS} = 0V$, $T_a = 25^\circ C$)

Parameter	Symbol	Limits	Unit
Power supply voltage	V_{DD}	- 0.3 ~ + 18	V
Power dissipation	P_d	1000 (DIP), 450 (SOP)	mW
Operating temperature	T_{opr}	- 40 ~ + 85	°C
Storage temperature	T_{stg}	- 55 ~ + 150	°C
Input voltage	V_{IN}	- 0.3 ~ $V_{DD} + 0.3$	V

●Truth table

INPUT		OUTPUT
A	B	
L	L	L
L	H	H
H	L	H
H	H	L

●Block diagram

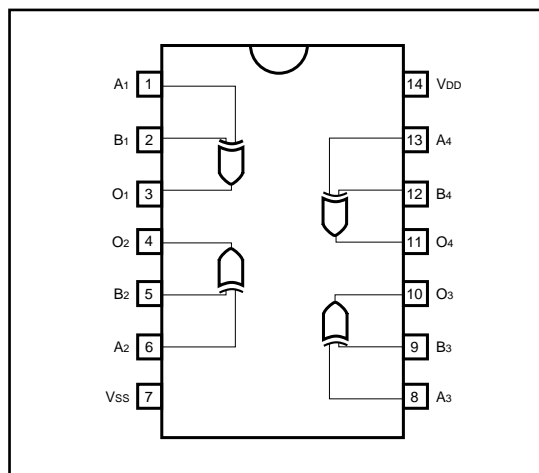

Standard ICs

BU4030B / BU4030BF / BU4070B / BU4070BF

●Electrical characteristics

DC characteristics (unless otherwise noted, $V_{SS} = 0V$, $T_a = 25^\circ C$)

Parameter	Symbol	Min.	Typ.	Max.	Unit	V _{DD} (V)	Conditions	Measurement circuit
Input high level voltage	V _{IH}	3.5	—	—	V	5	—	Fig.1
		7.0	—	—		10		
		11.0	—	—		15		
Input low level voltage	V _{IL}	—	—	1.5	V	5	—	Fig.1
		—	—	3.0		10		
		—	—	4.0		15		
Input high level current	I _{IH}	—	—	0.3	μA	15	V _{IH} = 15V	Fig.1
Input low level current	I _{IL}	—	—	-0.3	μA	15	V _{IL} = 0V	Fig.1
Output high level voltage	V _{OH}	4.95	—	—	V	5	I _O = 0mA	Fig.1
		9.95	—	—		10		
		14.95	—	—		15		
Output low level voltage	V _{OL}	—	—	0.05	V	5	I _O = 0mA	Fig.1
		—	—	0.05		10		
		—	—	0.05		15		
Output high level current	I _{OH}	-0.16	—	—	mA	5	V _{OH} = 4.6V	Fig.1
		-0.4	—	—		10	V _{OH} = 9.5V	
		-1.2	—	—		15	V _{OH} = 13.5V	
Output low level current	I _{OL}	0.44	—	—	mA	5	V _{OL} = 0.4V	Fig.1
		1.1	—	—		10	V _{OL} = 0.5V	
		3.0	—	—		15	V _{OL} = 1.5V	
Static current dissipation	I _{DD}	—	—	1	μA	5	V _I = V _{DD} or GND	—
		—	—	2		10		
		—	—	4		15		

Switching characteristics (unless otherwise noted, $V_{SS} = 0V$, $T_a = 25^\circ C$, $C_L = 50 pF$)

Parameter	Symbol	Min.	Typ.	Max.	Unit.	V _{DD} (V)	Conditions	Measurement circuit
						5		
Output rise time	t _{TLH}	—	180	—	ns	10	—	Fig.2
		—	90	—		15		
		—	65	—		5		
Output fall time	t _{THL}	—	100	—	ns	10	—	Fig.2
		—	50	—		15		
		—	40	—		5		
"L" to "H" propagation delay time	t _{PLH}	—	175	—	ns	10	—	Fig.2
		—	75	—		15		
		—	50	—		5		
"H" to "L" propagation delay time	t _{PHL}	—	175	—	ns	10	—	Fig.2
		—	75	—		15		
		—	50	—		5		
Input capacitance	C _I	—	5	—	pF	—	—	—

●Measurement circuits

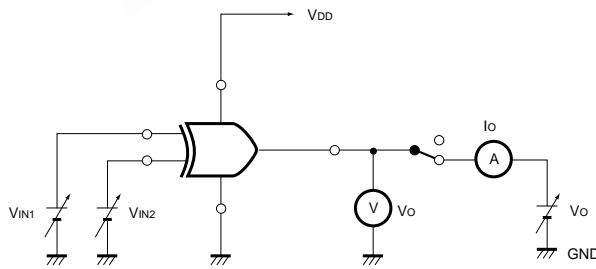

Fig. 1 DC characteristics measurement circuit

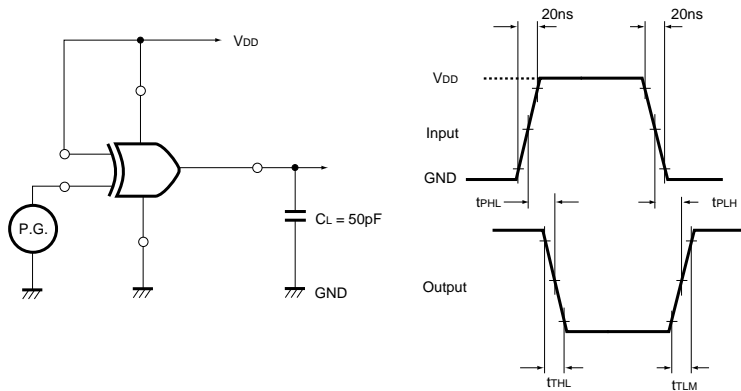

Fig. 2 Switching characteristics measurement circuit

●Electrical characteristic curve

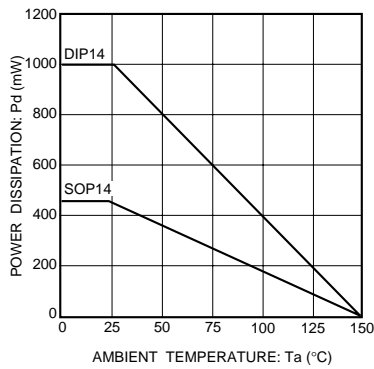

Fig.3 Power dissipation vs. Ta

●External dimensions (Units: mm)

