

74F583 4-Bit BCD Adder

General Description

The 'F583 high-speed 4-bit, BCD full adder with internal carry lookahead accepts two 4-bit decimal numbers (A_0 – A_3 , B_0 – B_3) and a Carry Input (C_n). It generates the decimal sum outputs (S_0 – S_3), and a Carry Output (C_{n+4}) if the sum is greater than 9. The 'F583 is the functional equivalent of the 82S83.

Features

- Adds two decimal numbers
- Full internal lookahead
- Fast ripple carry for economical expansion
- Sum output delay time 16.5 ns max
- Ripple carry delay time 8.5 ns max
- Input to ripple delay time 14.0 ns max
- Supply current 60 mA max

Ordering Code:

Order Number	Package Number	Package Description
74F583SC	M16B	16-Lead Small Outline Intergrated Circuit (SOIC), JEDEC MS-013, 0.300 Wide
74F583PC	N16E	16-Lead Plastic Dual-In-Line Package (PDIP), JEDEC MS-001, 0.300 Wide

Logic Symbols

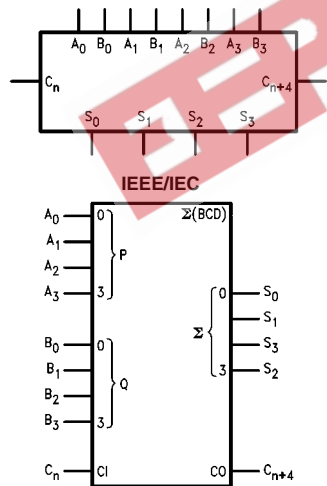

Connection Diagram

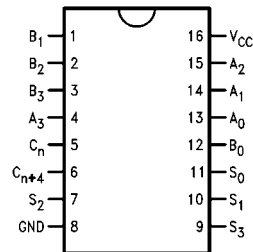

Unit Loading/Fan Out

Pin Names	Description	74F	
		U.L. HIGH/LOW	Input I_{IH}/I_{IL} Output I_{OH}/I_{OL}
A_0 – A_3	A Operand Inputs	1.0/2.0	20 μ A/–1.2 mA
B_0 – B_3	B Operand Inputs	1.0/2.0	20 μ A/–1.2 mA
C_n	Carry Input	1.0/1.0	20 μ A/–0.6 mA
S_0 – S_3	Sum Outputs	50/33.3	–1 mA/20 mA
C_{n+4}	Carry Output	50/33.3	–1 mA/20 mA

Functional Description

The 'F583 4-bit binary coded (BCD) full adder performs the addition of two decimal numbers (A_0 – A_3 , B_0 – B_3). The look-ahead generates the BCD carry terms internally, allowing the 'F583 to then do BCD addition correctly. For BCD numbers 0 through 9 at A and B inputs, the BCD sum forms at the output. In the addition of two BCD numbers totalling a number greater than 9, a valid BCD number and a carry will result.

For input values larger than 9, the number is converted from binary to BCD. Binary to BCD conversion occurs by grounding one set of inputs, A_n or B_n , and applying any 4-bit binary number to the other set of inputs. If the input is between 0 and 9, a BCD number occurs at the output. If the binary input falls between 10 and 15, a carry term is generated. Both the carry term and the sum are the BCD equivalent of the binary input. Converting binary numbers greater than 16 may be achieved through cascading 'F583s.

Logic Diagram

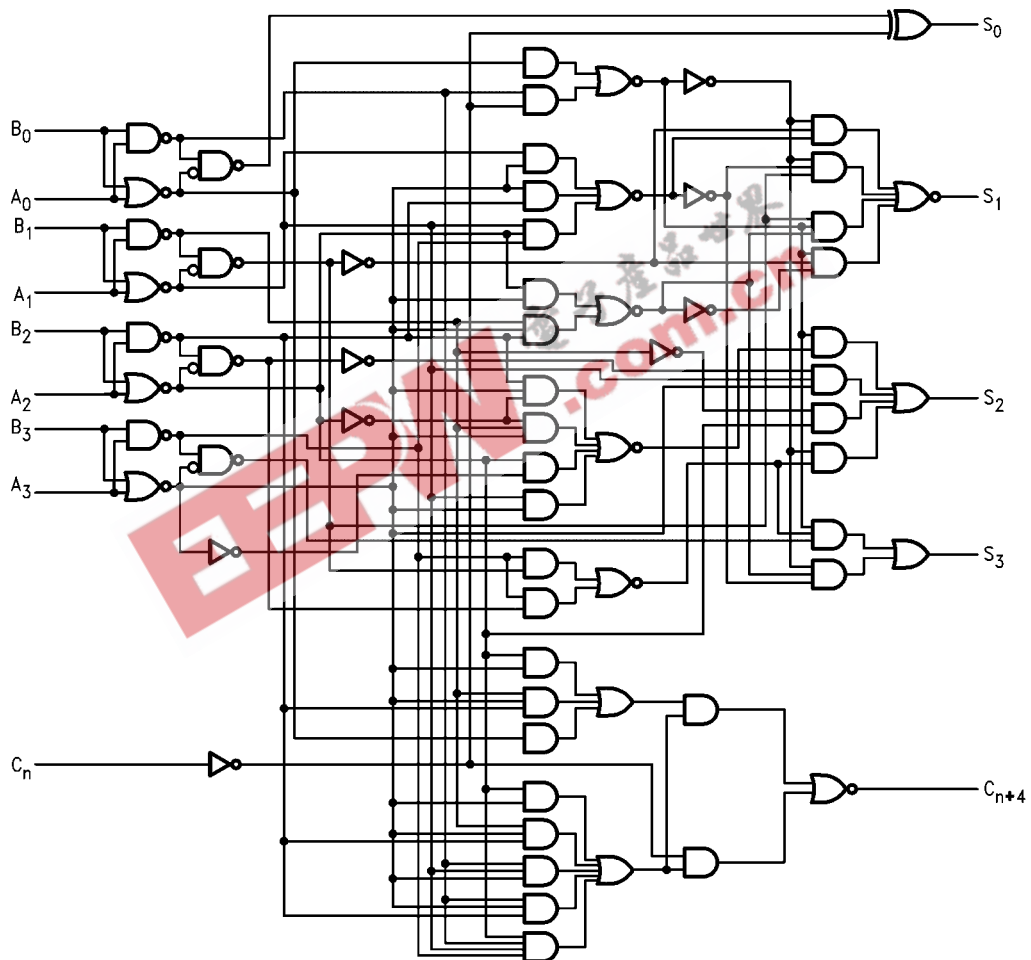

Please note that this diagram is provided only for the understanding of logic operations and should not be used to estimate propagation delays.

Absolute Maximum Ratings (Note 1)

Storage Temperature	-65°C to +150°C
Ambient Temperature under Bias	-55°C to +125°C
Junction Temperature under Bias	-55°C to +175°C
Plastic	-55°C to +150°C
V _{CC} Pin Potential to	
Ground Pin	-0.5V to +7.0V
Input Voltage (Note 2)	-0.5V to +7.0V
Input Current (Note 2)	-30 mA to +5.0 mA
Voltage Applied to Output	
in HIGH State (with V _{CC} = 0V)	
Standard Output	-0.5V to V _{CC}
3-STATE Output	-0.5V to +5.5V
Current Applied to Output	
in LOW State (Max)	twice the rated I _{OL} (mA)

Recommended Operating Conditions

Free Air Ambient Temperature	
Commercial	0°C to +70°C
Supply Voltage	
Commercial	+4.5V to +5.5V

Note 1: Absolute maximum ratings are values beyond which the device may be damaged or have its useful life impaired. Functional operation under these conditions is not implied.

Note 2: Either voltage limit or current limit is sufficient to protect inputs.

DC Electrical Characteristics

Symbol	Parameter	74F			Units	V _{CC}	Conditions
		Min	Typ	Max			
V _{IH}	Input HIGH Voltage	2.0			V		Recognized as a HIGH Signal
V _{IL}	Input LOW Voltage			0.8	V		Recognized as a LOW Signal
V _{CD}	Input Clamp Diode Voltage			-1.2	V	Min	I _{IN} = -18 mA
V _{OH}	Output HIGH Voltage	74F 10% V _{CC}	2.5		V	Min	I _{OH} = -1 mA
		74F 5% V _{CC}	2.7				I _{OH} = -1 mA
V _{OL}	Output LOW Voltage	74F 10% V _{CC}		0.5	V	Min	I _{OL} = 20 mA
I _{IH}	Input HIGH Current			20	μA	Max	V _{IN} = 2.7V
I _{BVI}	Input HIGH Current Breakdown Test			100	μA	Max	V _{IN} = 7.0V
I _{IL}	Input LOW Current			-0.6	mA	Max	V _{IN} = 0.5V (C _n)
				-1.2			V _{IN} = 0.5V (A _n , B _n)
I _{OS}	Output Short-Circuit Current	-60		-150	mA	Max	V _{OUT} = 0V
I _{CEx}	Output HIGH Leakage Current			250	μA	Max	V _{OUT} = V _{CC}
I _{CCL}	Power Supply Current		40	60	mA	Max	V _O = LOW

AC Electrical Characteristics

Symbol	Parameter	74F			74F		Units
		T _A = +25°C			T _A , V _{CC} = Com		
		V _{CC} = +5.0V			C _L = 50 pF		
		Min	Typ	Max	Min	Max	
t _{PLH}	Propagation Delay	2.5	13.0	16.5	2.5	17.5	ns
t _{PHL}	A _n or B _n to S _n	2.5	11.0	14.0	2.5	15.0	
t _{PLH}	Propagation Delay	2.5	6.5	8.5	2.5	9.5	ns
t _{PHL}	C _n to C _{n+4}	2.5	5.0	6.5	2.5	7.5	
t _{PLH}	Propagation Delay	4.0	11.0	14.0	4.0	15.0	ns
t _{PHL}	A _n or B _n to C _{n+4}	4.0	8.0	10.5	4.0	11.5	

Physical Dimensions inches (millimeters) unless otherwise noted

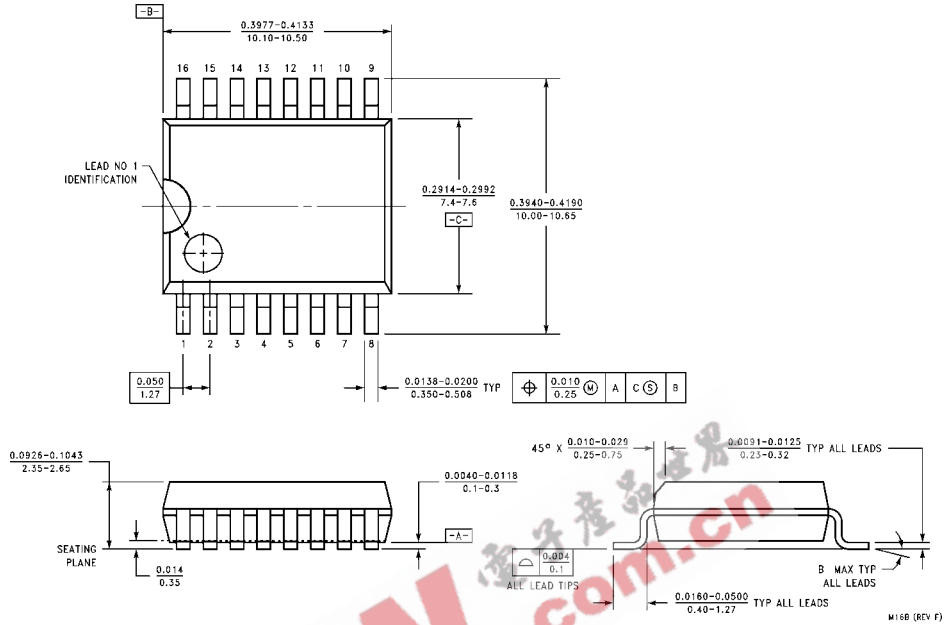

16-Lead Small Outline Intergrated Circuit (SOIC), JEDEC MS-013, 0.300 Wide Package Number M16B

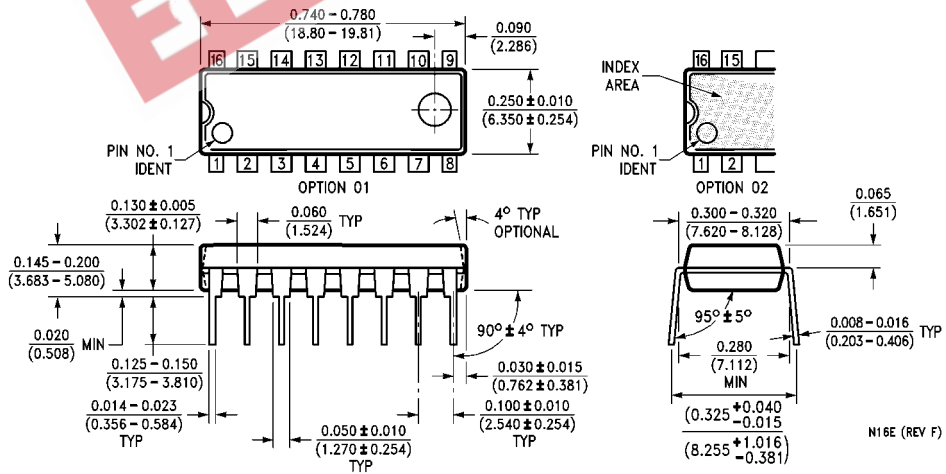

16-Lead Plastic Dual-In-Line Package (PDIP), JEDEC MS-001, 0.300 Wide Package Number N16E

EEPW 电子产品世界
.com.cn

LIFE SUPPORT POLICY

FAIRCHILD'S PRODUCTS ARE NOT AUTHORIZED FOR USE AS CRITICAL COMPONENTS IN LIFE SUPPORT DEVICES OR SYSTEMS WITHOUT THE EXPRESS WRITTEN APPROVAL OF THE PRESIDENT OF FAIRCHILD SEMICONDUCTOR CORPORATION. As used herein:

1. Life support devices or systems are devices or systems which, (a) are intended for surgical implant into the body, or (b) support or sustain life, and (c) whose failure to perform when properly used in accordance with instructions for use provided in the labeling, can be reasonably expected to result in a significant injury to the user.
2. A critical component in any component of a life support device or system whose failure to perform can be reasonably expected to cause the failure of the life support device or system, or to affect its safety or effectiveness.

www.fairchildsemi.com