

74AC169 4-Stage Synchronous Bidirectional Counter

General Description

The AC169 is fully synchronous 4-stage up/down counter. The AC169 is a modulo-16 binary counter. It features a preset capability for programmable operation, carry lookahead for easy cascading and a U/\bar{D} input to control the direction of counting. All state changes, whether in counting or parallel loading, are initiated by the LOW-to-HIGH transition of the Clock.

Features

- I_{CC} reduced by 50%
- Synchronous counting and loading
- Built-In lookahead carry capability
- Presetable for programmable operation
- Outputs source/sink 24 mA

Ordering Code:

Order Number	Package Number	Package Description
74AC169SC	M16A	16-Lead Small Outline Integrated Circuit (SOIC), JEDEC MS-012, 0.150" Narrow Body
74AC169SJ	M16D	16-Lead Small Outline Package (SOP), EIAJ TYPE II, 5.3mm Wide
74AC169MTC	MTC16	16-Lead Thin Shrink Small Outline Package (TSSOP), JEDEC MO-153, 4.4mm Wide
74AC169PC	N16E	16-Lead Plastic Dual-In-Line Package (PDIP), JEDEC MS-001, 0.300" Wide

Device also available in Tape and Reel. Specify by appending suffix letter "X" to the ordering code.

Logic Symbols

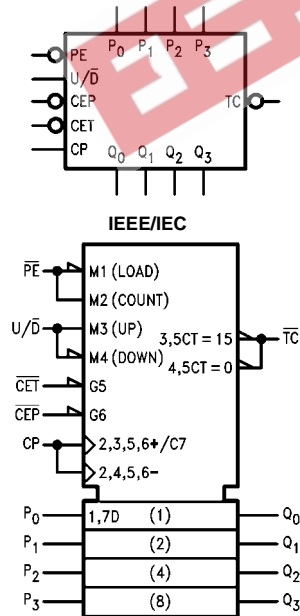

Connection Diagram

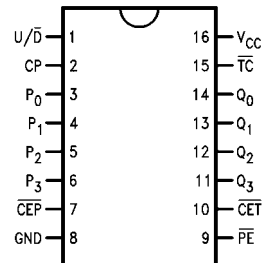

Pin Descriptions

Pin Names	Description
\overline{CEP}	Count Enable Parallel Input
\overline{CET}	Count Enable Trickle Input
CP	Clock Pulse Input
P_0 - P_3	Parallel Data Inputs
\overline{PE}	Parallel Enable Input
U/\bar{D}	Up-Down Count Control Input
Q_0 - Q_3	Flip-Flop Outputs
\overline{TC}	Terminal Count Output

FACT™ is a trademark of Fairchild Semiconductor Corporation.

Functional Description

The AC169 uses edge-triggered J-K-type flip-flops and have no constraints on changing the control or data input signals in either state of the Clock. The only requirement is that the various inputs attain the desired state at least a setup time before the rising edge of the clock and remain valid for the recommended hold time thereafter. The parallel load operation takes precedence over the other operations, as indicated in the Mode Select Table. When \overline{PE} is LOW, the data on the P_0 - P_3 inputs enters the flip-flops on the next rising edge of the Clock. In order for counting to occur, both \overline{CEP} and \overline{CET} must be LOW and \overline{PE} must be HIGH; the U/D input then determines the direction of counting. The Terminal Count (\overline{TC}) output is normally HIGH and goes LOW, provided that \overline{CET} is LOW, when a counter reaches zero in the Count Down mode or reaches 15 in the Count Up mode. The \overline{TC} output state is not a function of the Count Enable Parallel (\overline{CEP}) input level. If an illegal state occurs, the AC169 will return to the legitimate sequence within two counts. Since the \overline{TC} signal is derived by decoding the flip-flop states, there exists the possibility of decoding spikes on \overline{TC} . For this reason the use of \overline{TC} as a clock signal is not recommended (see logic equations below).

- Count Enable = $\overline{CEP} \cdot \overline{CET} \cdot \overline{PE}$
- Up: $\overline{TC} = Q_0 \cdot Q_1 \cdot Q_2 \cdot Q_3 \cdot (Up) \cdot \overline{CET}$
- Down: $\overline{TC} = \overline{Q_0} \cdot \overline{Q_1} \cdot \overline{Q_2} \cdot \overline{Q_3} \cdot (Down) \cdot \overline{CET}$

Logic Diagram

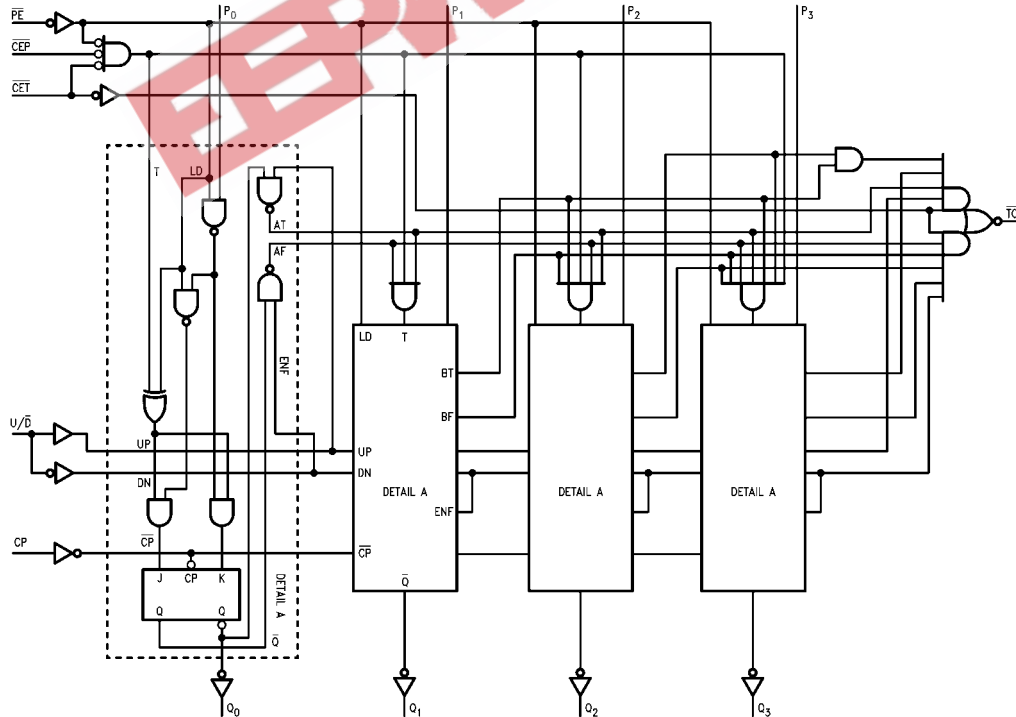

Mode Select Table

\overline{PE}	\overline{CEP}	\overline{CET}	U/D	Action on Rising Clock Edge
L	X	X	X	Load (P_n to Q_n)
H	L	L	H	Count Up (Increment)
H	L	L	L	Count Down (Decrement)
H	H	X	X	No Change (Hold)
H	X	H	X	No Change (Hold)

H = HIGH Voltage Level
L = LOW Voltage Level
X = Immaterial

State Diagram

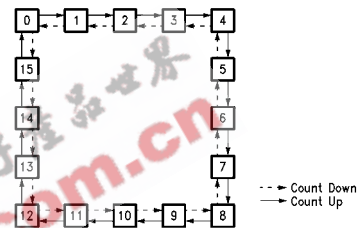

Absolute Maximum Ratings (Note 1)		Recommended Operating Conditions	
Supply Voltage (V_{CC})	-0.5V to +7.0V	Supply Voltage (V_{CC})	2.0V to 6.0V
DC Input Diode Current (I_{IK})		Input Voltage (V_I)	0V to V_{CC}
$V_I = -0.5V$	-20 mA	Output Voltage (V_O)	0V to V_{CC}
$V_I = V_{CC} + 0.5V$	+20 mA	Operating Temperature (T_A)	-40°C to +85°C
DC Input Voltage (V_I)	-0.5V to $V_{CC} + 0.5V$	Minimum Input Edge Rate ($\Delta V/\Delta t$)	
DC Output Diode Current (I_{OK})		V_{IN} from 30% to 70% of V_{CC}	
$V_O = -0.5V$	-20 mA	V_{CC} @ 3.3V, 4.5V, 5.5V	125 mV/ns
$V_O = V_{CC} + 0.5V$	+20 mA		
DC Output Voltage (V_O)	-0.5V to $V_{CC} + 0.5V$		
DC Output Source			
or Sink Current (I_O)	± 50 mA		
DC V_{CC} or Ground Current			
per Output Pin (I_{CC} or I_{GND})	± 50 mA		
Storage Temperature (T_{STG})	-65°C to +150°C		
Junction Temperature (T_J)			
PDIP	140°C		

Note 1: Absolute maximum ratings are those values beyond which damage to the device may occur. The databook specifications should be met, with-out exception, to ensure that the system design is reliable over its power supply, temperature, and output/input loading variables. Fairchild does not recommend operation of FACT™ circuits outside databook specifications.

DC Electrical Characteristics

Symbol	Parameter	V_{CC} (V)	$T_A = +25^\circ\text{C}$		$T_A = -40^\circ\text{C to } +85^\circ\text{C}$		Units	Conditions
			Typ	Guaranteed Limits	Guaranteed Limits	Guaranteed Limits		
V_{IH}	Minimum HIGH Level Input Voltage	3.0	1.5	2.1	2.1	V	$V_{OUT} = 0.1V$ or $V_{CC} - 0.1V$	
		4.5	2.25	3.15	3.15			
		5.5	2.75	3.85	3.85			
V_{IL}	Maximum LOW Level Input Voltage	3.0	1.5	0.9	0.9	V	$V_{OUT} = 0.1V$ or $V_{CC} - 0.1V$	
		4.5	2.25	1.35	1.35			
		5.5	2.75	1.65	1.65			
V_{OH}	Minimum HIGH Level Output Voltage	3.0	2.99	2.9	2.9	V	$I_{OUT} = -50 \mu A$	
		4.5	4.49	4.4	4.4			
		5.5	5.49	5.4	5.4			
			3.0		2.56	2.46	V	$V_{IN} = V_{IL}$ or V_{IH} $I_{OH} = -12$ mA $I_{OH} = -24$ mA $I_{OH} = -24$ mA (Note 2)
			4.5		3.86	3.76		
			5.5		4.86	4.76		
V_{OL}	Maximum LOW Level Output Voltage	3.0	0.002	0.1	0.1	V	$I_{OUT} = 50 \mu A$	
		4.5	0.001	0.1	0.1			
		5.5	0.001	0.1	0.1			
			3.0		0.36	0.44	V	$V_{IN} = V_{IL}$ or V_{IH} $I_{OL} = 12$ mA $I_{OL} = 24$ mA $I_{OL} = 24$ mA (Note 2)
			4.5		0.36	0.44		
			5.5		0.36	0.44		
I_{IN} (Note 4)	Maximum Input Leakage Current	5.5		± 0.1	± 1.0	μA	$V_I = V_{CC}$, GND	
I_{OLD}	Minimum Dynamic	5.5			75	mA	$V_{OLD} = 1.65V$ Max	
I_{OHD}	Output Current (Note 3)	5.5			-75	mA	$V_{OHD} = 3.85V$ Min	
I_{CC} (Note 4)	Maximum Quiescent Supply Current	5.5		4.0	40.0	μA	$V_{IN} = V_{CC}$ or GND	

Note 2: All outputs loaded; thresholds on input associated with output under test.

Note 3: Maximum test duration 2.0 ms, one output loaded at a time.

Note 4: I_{IN} and I_{CC} @ 3.0V are guaranteed to be less than or equal to the respective limit @ 5.5V V_{CC} .

AC Electrical Characteristics								
Symbol	Parameter	V _{CC} (V) (Note 5)	T _A = +25°C, C _L = 50 pF			T _A = -40°C to +85°C, C _L = 50 pF		Units
			Min	Typ	Max	Min	Max	
f _{MAX}	Maximum Clock Frequency	3.3	75	118		65		MHz
		5.0	100	154		90		
t _{PLH}	Propagation Delay CP to Q _n (\overline{PE} HIGH or LOW)	3.3	2.5	9.5	13.0	2.0	14.5	ns
		5.0	1.5	7.0	10.0	1.5	11.0	
t _{PHL}	Propagation Delay CP to Q _n (\overline{PE} HIGH or LOW)	3.3	2.5	10.5	14.5	2.0	16.0	ns
		5.0	1.5	7.5	11.0	1.5	12.0	
t _{PLH}	Propagation Delay CP to TC	3.3	4.5	13.5	18.0	3.5	22.0	ns
		5.0	3.0	9.5	13.0	2.0	14.0	
t _{PHL}	Propagation Delay CP to TC	3.3	3.5	13.5	18.0	3.0	20.5	ns
		5.0	2.5	9.5	13.0	2.0	14.5	
t _{PLH}	Propagation Delay \overline{CET} to TC	3.3	3.5	11.0	15.0	3.0	16.5	ns
		5.0	3.0	8.0	10.5	2.5	12.0	
t _{PHL}	Propagation Delay \overline{CET} to TC	3.3	3.0	9.5	12.5	2.5	14.5	ns
		5.0	2.0	7.0	9.0	1.5	10.0	
t _{PLH}	Propagation Delay U/D to TC	3.3	3.5	11.0	15.0	3.0	17.0	ns
		5.0	2.5	8.0	10.5	2.0	12.0	
t _{PHL}	Propagation Delay U/D to TC	3.3	2.5	10.0	13.5	2.0	15.5	ns
		5.0	1.5	7.0	9.5	1.5	10.5	

Note 5: Voltage Range 3.3 is 3.3V ± 0.3V Voltage Range 5.0 is 5.0V ± 0.5V

AC Operating Requirements						
Symbol	Parameter	V _{CC} (V) (Note 6)	T _A = +25°C, C _L = 50 pF	T _A = -40°C to +85°C, C _L = 50 pF		Units
			Typ	Guaranteed Minimum		
t _S	Setup Time, HIGH or LOW P _n to CP	3.3	3.0	4.5	5.0	ns
		5.0	1.5	2.5	2.5	
t _H	Hold Time, HIGH or LOW P _n to CP	3.3	-1.5	0.5	0.5	ns
		5.0	-0.5	1.5	1.5	
t _S	Setup Time, HIGH or LOW \overline{CEP} to CP	3.3	7.5	10.5	12.5	ns
		5.0	4.5	7.0	8.0	
t _H	Hold Time, HIGH or LOW \overline{CEP} to CP	3.3	-4.5	0	0	ns
		5.0	-2.0	0.5	1.0	
t _S	Setup Time, HIGH or LOW \overline{CET} to CP	3.3	7.0	10.0	12.0	ns
		5.0	4.0	6.5	8.0	
t _H	Hold Time, HIGH or LOW \overline{CET} to CP	3.3	-6.0	0	0	ns
		5.0	-4.0	0.5	1.0	
t _S	Setup Time, HIGH or LOW PE to CP	3.3	3.5	5.5	6.5	ns
		5.0	2.0	3.5	4.0	
t _H	Hold Time, HIGH or LOW PE to CP	3.3	-3.5	0	0	ns
		5.0	-1.5	0.5	0.5	
t _S	Setup Time, HIGH or LOW U/D to CP	3.3	7.0	10.0	11.5	ns
		5.0	4.5	6.5	7.5	
t _H	Hold Time, HIGH or LOW U/D to CP	3.3	-7.0	0	0	ns
		5.0	-4.0	0.5	0.5	
t _W	CP Pulse Width, HIGH or LOW	3.3	2.0	3.0	4.0	ns
		5.0	2.0	3.0	3.0	

Note 6: Voltage Range 3.3 is 3.3V ± 0.3V Voltage Range 5.0 is 5.0V ± 0.5V

Capacitance				
Symbol	Parameter	Typ	Units	Conditions
C _{IN}	Input Capacitance	4.5	pF	V _{CC} = OPEN
C _{PD}	Power Dissipation Capacitance	60.0	pF	V _{CC} = 5.0V

Physical Dimensions inches (millimeters) unless otherwise noted

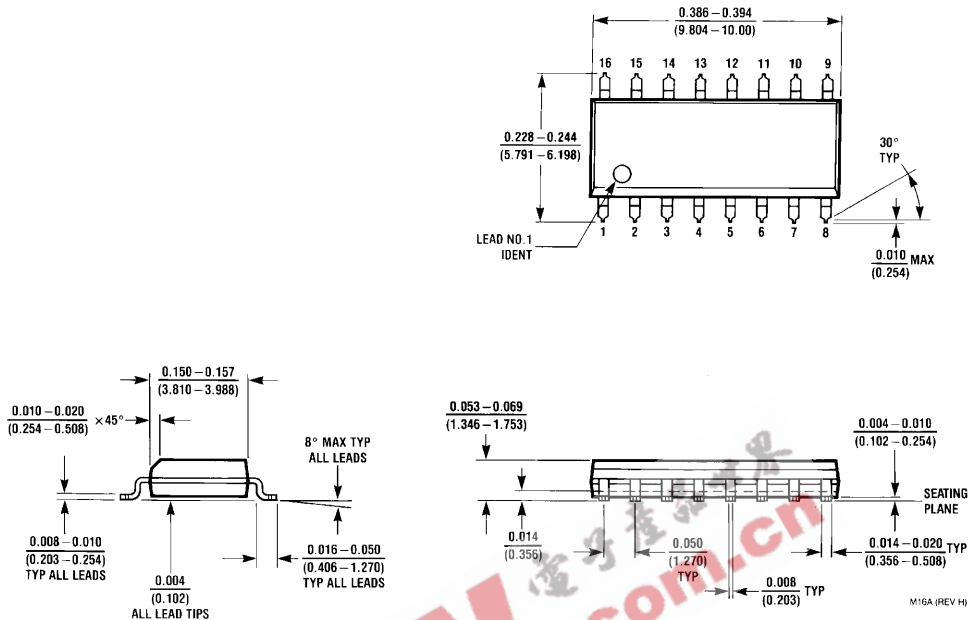

16-Lead Small Outline Integrated Circuit (SOIC), JEDEC MS-012, 1.150" Narrow Body
Package Number M16A

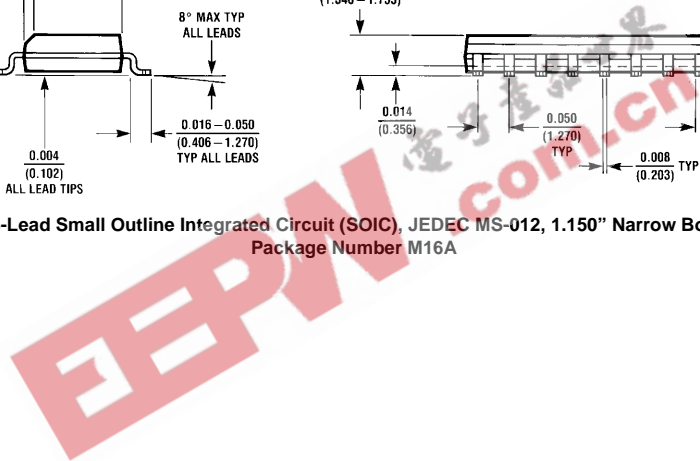

Physical Dimensions inches (millimeters) unless otherwise noted (Continued)

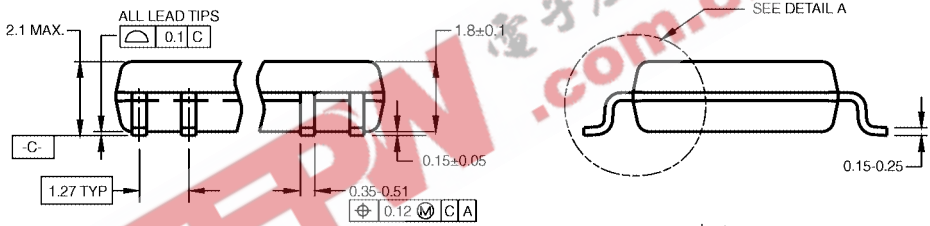
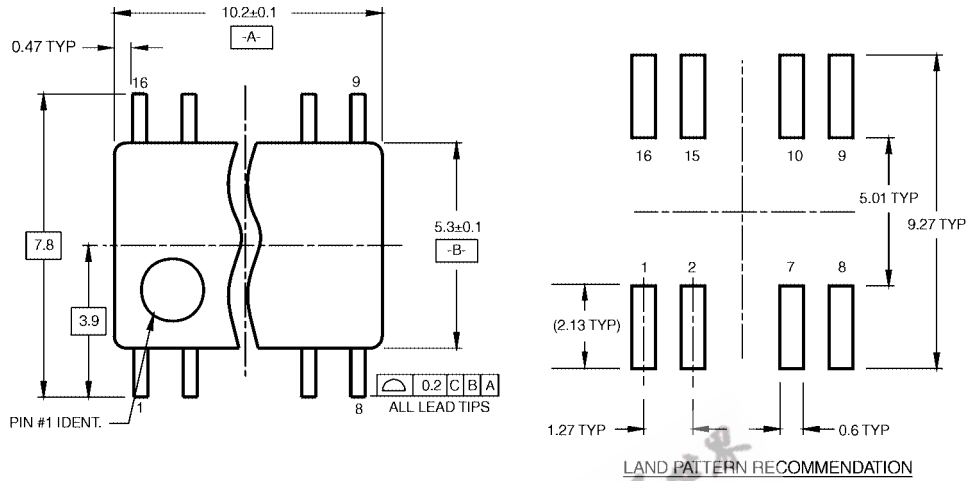

DIMENSIONS ARE IN MILLIMETERS

- NOTES:
- A. CONFORMS TO EIAJ EDR-7320 REGISTRATION, ESTABLISHED IN DECEMBER, 1998.
 - B. DIMENSIONS ARE IN MILLIMETERS.
 - C. DIMENSIONS ARE EXCLUSIVE OF BURRS, MOLD FLASH, AND TIE BAR EXTRUSIONS.

M16DRRevB1

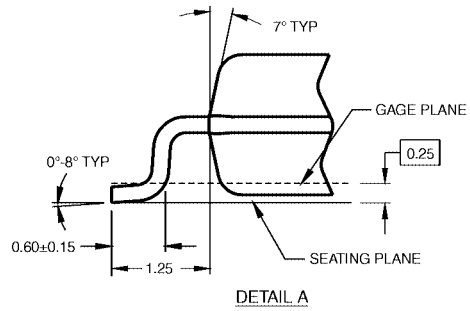

16-Lead Small Outline Package (SOP), EIAJ TYPE II, 5.3mm Wide Package Number M16D

Physical Dimensions inches (millimeters) unless otherwise noted (Continued)

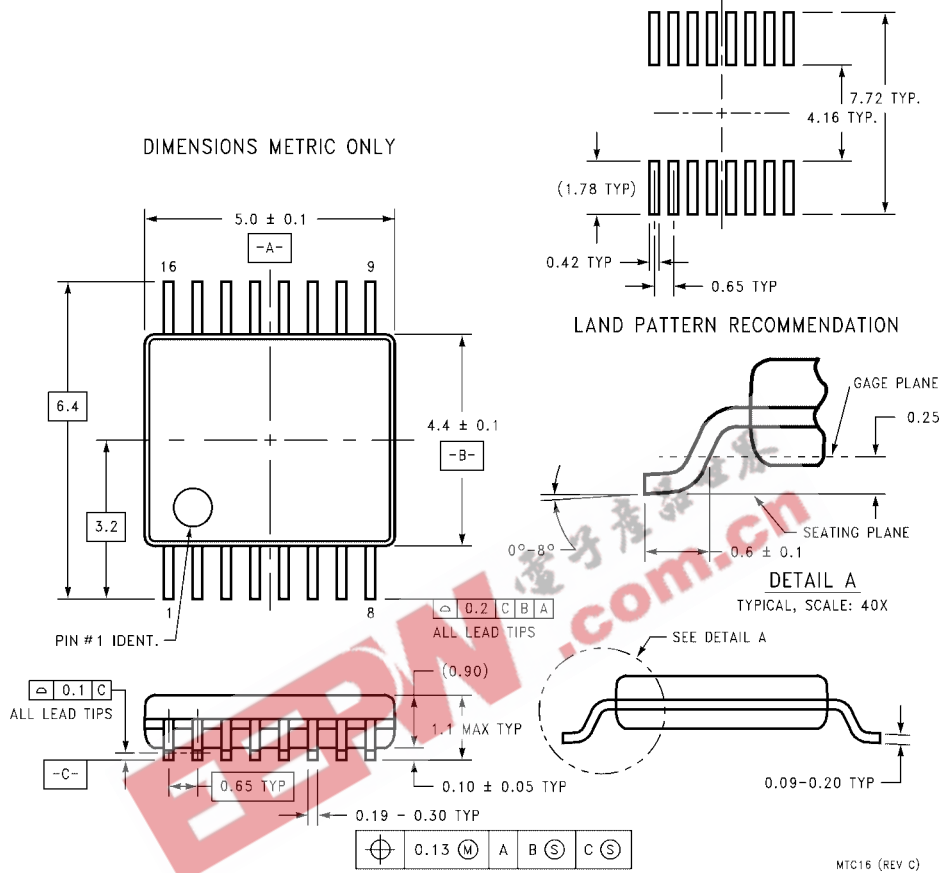

**16-Lead Thin Shrink Small Outline Package (TSSOP), JEDEC MO-153, 4.4mm Wide
Package Number MTC16**

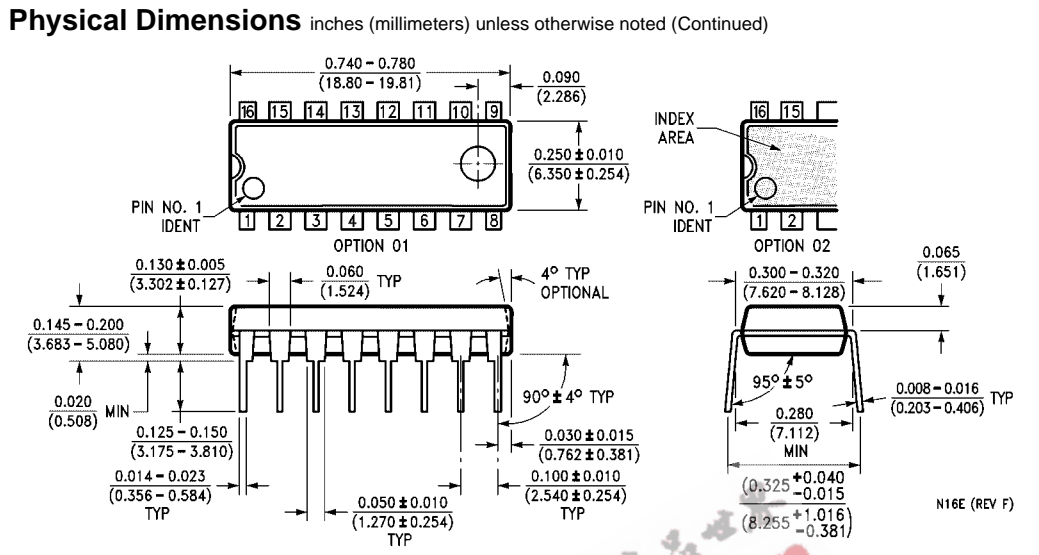

16-Lead Plastic Dual-In-Line Package (PDIP), JEDEC MS-001, 0.300" Wide Package Number N16E

Fairchild does not assume any responsibility for use of any circuitry described, no circuit patent licenses are implied and Fairchild reserves the right at any time without notice to change said circuitry and specifications.

LIFE SUPPORT POLICY

FAIRCHILD'S PRODUCTS ARE NOT AUTHORIZED FOR USE AS CRITICAL COMPONENTS IN LIFE SUPPORT DEVICES OR SYSTEMS WITHOUT THE EXPRESS WRITTEN APPROVAL OF THE PRESIDENT OF FAIRCHILD SEMICONDUCTOR CORPORATION. As used herein:

1. Life support devices or systems are devices or systems which, (a) are intended for surgical implant into the body, or (b) support or sustain life, and (c) whose failure to perform when properly used in accordance with instructions for use provided in the labeling, can be reasonably expected to result in a significant injury to the user.
2. A critical component in any component of a life support device or system whose failure to perform can be reasonably expected to cause the failure of the life support device or system, or to affect its safety or effectiveness.

www.fairchildsemi.com