

54LS194A/DM74LS194A 4-Bit Bidirectional Universal Shift Register

General Description

This bidirectional shift register is designed to incorporate virtually all of the features a system designer may want in a shift register; they feature parallel inputs, parallel outputs, right-shift and left-shift serial inputs, operating-mode-control inputs, and a direct overriding clear line. The register has four distinct modes of operation, namely:

- Parallel (broadside) load
- Shift right (in the direction Q_A toward Q_D)
- Shift left (in the direction Q_D toward Q_A)
- Inhibit clock (do nothing)

Synchronous parallel loading is accomplished by applying the four bits of data and taking both mode control inputs, S_0 and S_1 , high. The data is loaded into the associated flip-flops and appear at the outputs after the positive transition of the clock input. During loading, serial data flow is inhibited.

Shift right is accomplished synchronously with the rising edge of the clock pulse when S_0 is high and S_1 is low.

Serial data for this mode is entered at the shift-right data input. When S_0 is low and S_1 is high, data shifts left synchronously and new data is entered at the shift-left serial input.

Clocking of the flip-flop is inhibited when both mode control inputs are low.

Features

- Parallel inputs and outputs
- Four operating modes:
 - Synchronous parallel load
 - Right shift
 - Left shift
 - Do nothing
- Positive edge-triggered clocking
- Direct overriding clear

Connection Diagram

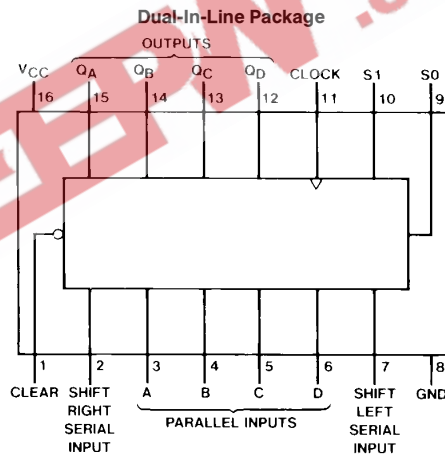

TL/F/6407-1

Order Number 54LS194ADMQB, 54LS194AFMQB,
54LS194ALMQB, DM74LS194AM or DM74LS194AN
See NS Package Number E20A, J16A, M16A, N16E or W16A

Absolute Maximum Ratings (Note)

If Military/Aerospace specified devices are required, please contact the National Semiconductor Sales Office/Distributors for availability and specifications.

Supply Voltage	7V
Input Voltage	7V
Operating Free Air Temperature Range	
54LS	−55°C to +125°C
DM74LS	0°C to +70°C
Storage Temperature Range	−65°C to +150°C

Note: The "Absolute Maximum Ratings" are those values beyond which the safety of the device cannot be guaranteed. The device should not be operated at these limits. The parametric values defined in the "Electrical Characteristics" table are not guaranteed at the absolute maximum ratings. The "Recommended Operating Conditions" table will define the conditions for actual device operation.

Recommended Operating Conditions

Symbol	Parameter	54LS194A			DM74LS194A			Units
		Min	Nom	Max	Min	Nom	Max	
V _{CC}	Supply Voltage	4.5	5	5.5	4.75	5	5.25	V
V _{IH}	High Level Input Voltage	2			2			V
V _{IL}	Low Level Input Voltage			0.7			0.8	V
I _{OH}	High Level Output Current			−0.4			−0.4	mA
I _{OL}	Low Level Output Current			4			8	mA
f _{CLK}	Clock Frequency (Note 1)	30		0	0		25	MHz
	Clock Frequency (Note 2)	22			0		20	
t _W	Pulse Width (Note 3)	Clock	17				20	ns
		Clear	12				20	
t _{SU}	Setup Time (Note 3)	Mode	25				30	ns
		Data	16				20	
t _H	Hold Time (Note 3)	0			0			ns
t _{REL}	Clear Release Time (Note 3)	18			25			ns
T _A	Free Air Operating Temperature	−55		125	0		70	°C

Note 1: C_L = 15 pF, T_A = 25°C and V_{CC} = 5V.

Note 2: C_L = 50 pF, R_L = 2 kΩ, T_A = 25°C and V_{CC} = 5V.

Note 3: T_A = 25°C and V_{CC} = 5V.

Electrical Characteristics over recommended operating free air temperature range (unless otherwise noted)

Symbol	Parameter	Conditions	Min	Typ (Note 4)	Max	Units
V _I	Input Clamp Voltage	V _{CC} = Min, I _I = −18 mA			−1.5	V
V _{OH}	High Level Output Voltage	V _{CC} = Min, I _{OH} = Max	54LS	2.5		V
		V _{IL} = Max, V _{IH} = Min	DM74	2.7	3.4	
V _{OL}	Low Level Output Voltage	V _{CC} = Min, I _{OL} = Max V _{IL} = Max, V _{IH} = Min	54LS		0.4	V
			DM74		0.35	
		I _{OL} = 4 mA, V _{CC} = Min			0.4	
I _I	Input Current @ Max Input Voltage	V _{CC} = Max, V _I = 7V			0.1	mA
I _{IH}	High Level Input Current	V _{CC} = Max, V _I = 2.7V			20	μA
I _{IL}	Low Level Input Current	V _{CC} = Max, V _I = 0.4V			−0.4	mA
I _{OS}	Short Circuit Output Current	V _{CC} = Max (Note 5)	54LS	−20	−100	mA
			DM74	−20	−100	
I _{CC}	Supply Current	V _{CC} = Max (Note 6)		15	23	mA

Note 4: All typicals are at V_{CC} = 5V, T_A = 25°C.

Note 5: Not more than one output should be shorted at a time, and the duration should not exceed one second.

Note 6: With all outputs open, inputs A through D grounded, and 4.5V applied to S0, S1, CLEAR, and the serial inputs, I_{CC} is tested with momentary ground, then 4.5V applied to CLOCK.

Switching Characteristics at $V_{CC} = 5V$ and $T_A = 25^\circ C$ (See Section 1 for Test Waveforms and Output Load)

Symbol	Parameter	From (Input) To (Output)	54LS		DM74LS		Units
			$C_L = 15\text{ pF}$		$C_L = 50\text{ pF}$ $R_L = 2\text{ k}\Omega$		
			Min	Max	Min	Max	
f_{MAX}	Maximum Clock Frequency		30		20		MHz
t_{PLH}	Propagation Delay Time Low to High Level Output	Clock to Any Q		21		26	ns
t_{PHL}	Propagation Delay Time High to Low Level Output	Clock to Any Q		24		35	ns
t_{PHL}	Propagation Delay Time High to Low Output	Clear to Any Q		26		38	ns

Note 1: All typicals are at $V_{CC} = 5V$, $T_A = 25^\circ C$.

Note 2: Not more than one output should be shorted at a time, and the duration should not exceed one second.

Note 3: With all outputs open, inputs A through D grounded, and 4.5V applied to S0, S1, CLEAR, and the serial inputs, I_{CC} is tested with momentary ground, then 4.5V applied to CLOCK.

Logic Diagram

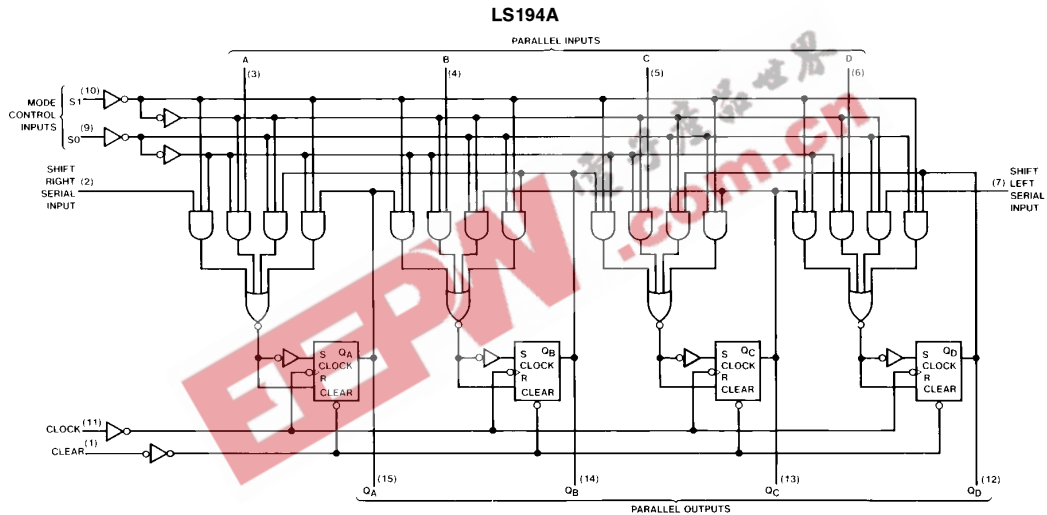

TL/F/6407-2

Function Table

Clear	Mode		Clock	Inputs				Outputs					
	S1	S0		Serial		Parallel				Q_A	Q_B	Q_C	Q_D
				Left	Right	A	B	C	D				
L	X	X	X	X	X	X	X	X	L	L	L	L	
H	X	X	L	X	X	X	X	X	Q_{A0}	Q_{B0}	Q_{C0}	Q_{D0}	
H	H	H	↑	X	X	a	b	c	d	a	b	c	d
H	L	H	↑	X	H	X	X	X	X	Q_{An}	Q_{Bn}	Q_{Cn}	Q_{Dn}
H	L	H	↑	X	L	X	X	X	X	L	Q_{An}	Q_{Bn}	Q_{Cn}
H	H	L	↑	H	X	X	X	X	X	Q_{Bn}	Q_{Cn}	Q_{Dn}	H
H	H	L	↑	L	X	X	X	X	X	Q_{Bn}	Q_{Cn}	Q_{Dn}	L
H	L	L	X	X	X	X	X	X	Q_{A0}	Q_{B0}	Q_{C0}	Q_{D0}	

H = High Level (steady state), L = Low Level (steady state), X = Don't Care (any input, including transitions)

↑ = Transition from low to high level

a, b, c, d = The level of steady state input at inputs A, B, C or D, respectively.

Q_{A0} , Q_{B0} , Q_{C0} , Q_{D0} = The level of Q_A , Q_B , Q_C , or Q_D , respectively, before the indicated steady state input conditions were established.

Q_{An} , Q_{Bn} , Q_{Cn} , Q_{Dn} = The level of Q_A , Q_B , Q_C , respectively, before the most-recent ↑ transition of the clock.

Timing Diagram

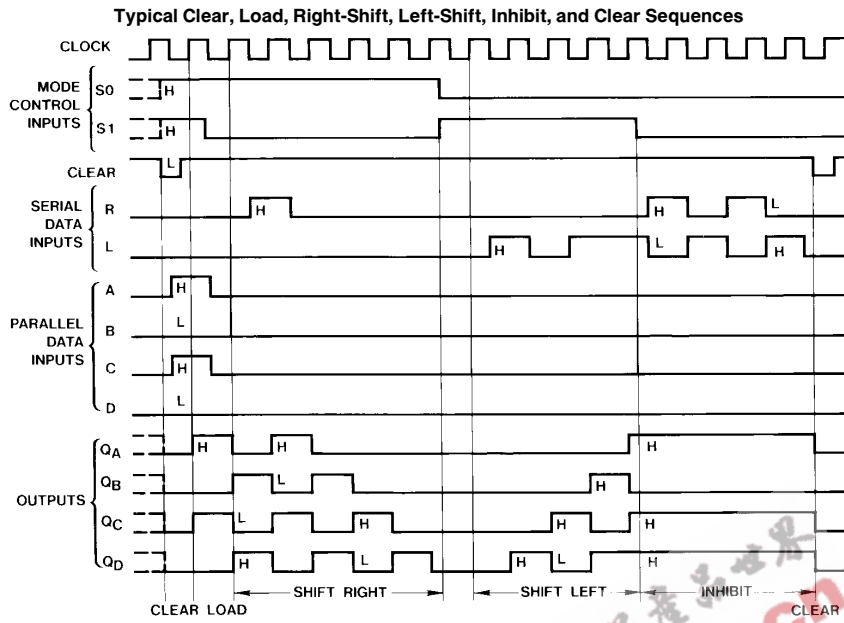

TL/F/6407-3

EEPW 电子产品世界
.com.cn

Physical Dimensions inches (millimeters)

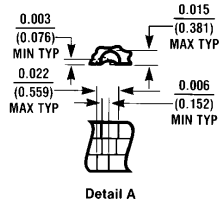
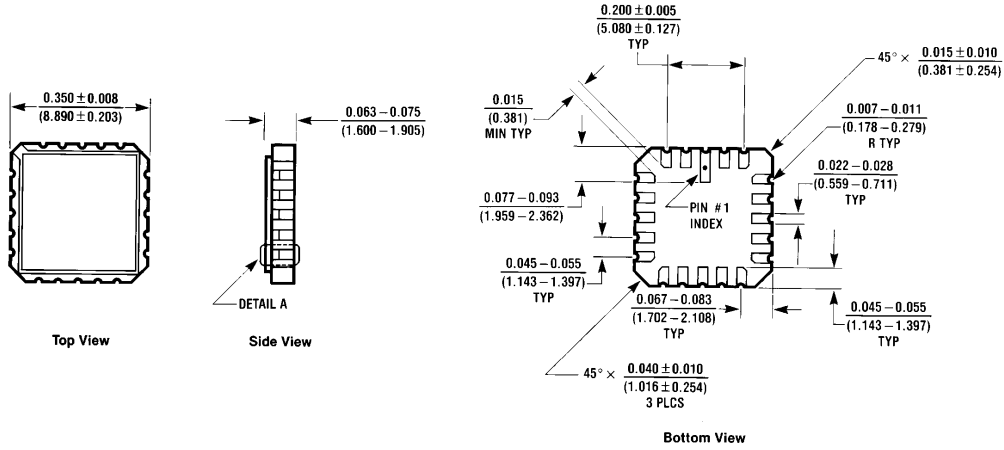

Ceramic Leadless Chip Carrier Package (E)
Order Number 54LS194ALMQB
NS Package Number E20A

E20A (REV D)

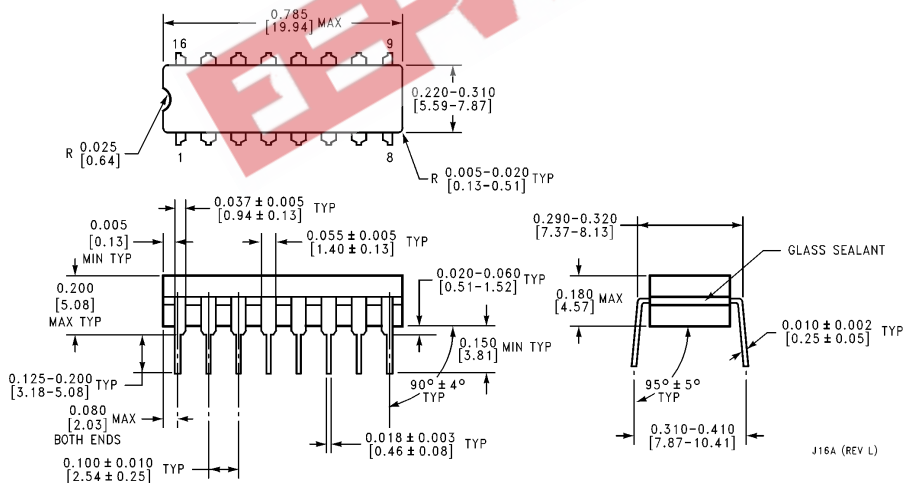

16-Lead Ceramic Dual-In-Line Package (J)
Order Number 54LS194ADMQB
NS Package Number J16A

J16A (REV L)

Physical Dimensions inches (millimeters) (Continued)

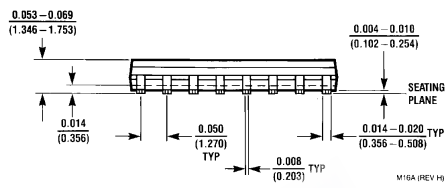
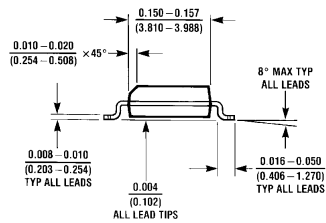
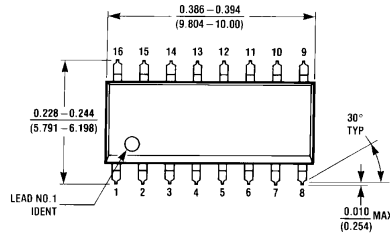

16-Lead Small Outline Molded Package (M)
Order Number DM74LS194AM
NS Package Number M16A

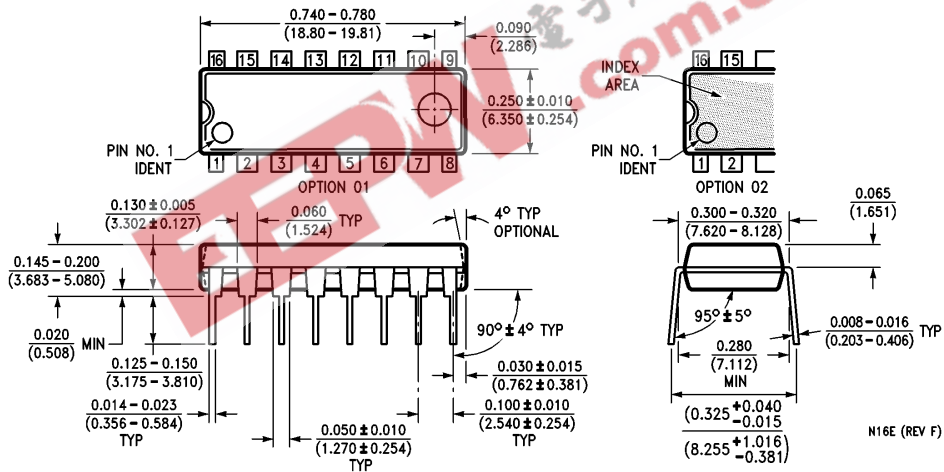

16-Lead Molded Dual-In-Line Package (N)
Order Number DM74LS194AN
NS Package Number N16E

Physical Dimensions inches (millimeters) (Continued)

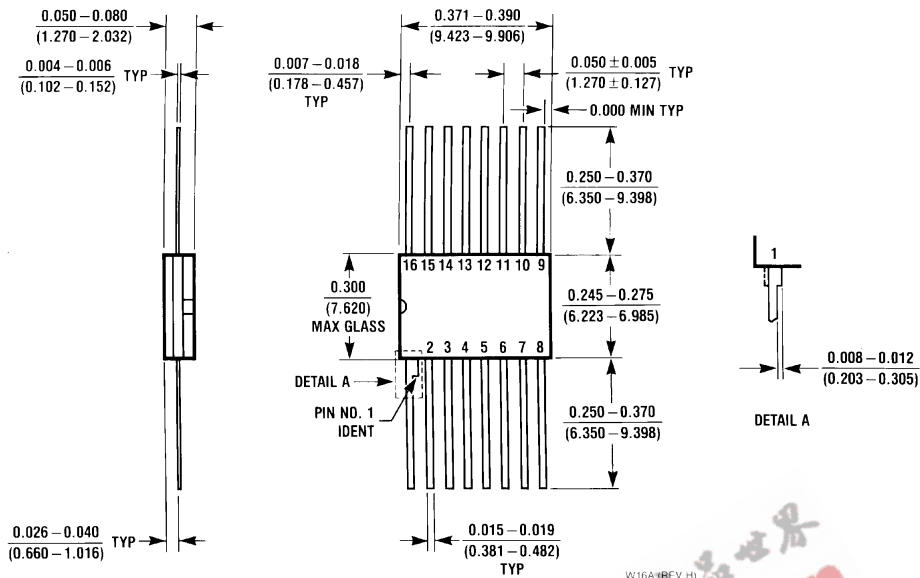

16-Lead Ceramic Flat Package (W)
Order Number 54LS194AFMQB
NS Package Number W16A

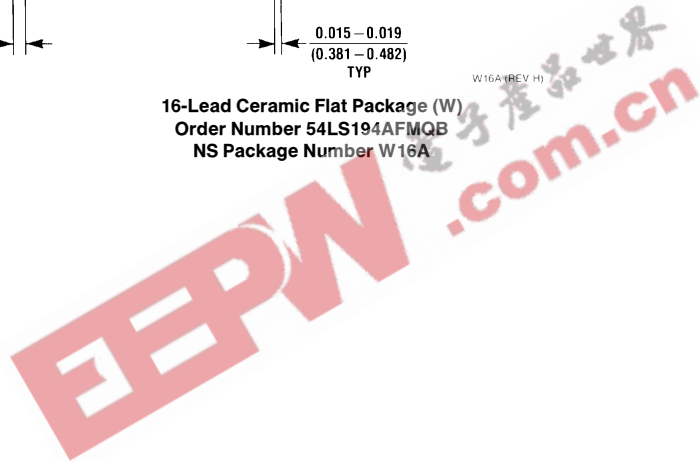

LIFE SUPPORT POLICY

NATIONAL'S PRODUCTS ARE NOT AUTHORIZED FOR USE AS CRITICAL COMPONENTS IN LIFE SUPPORT DEVICES OR SYSTEMS WITHOUT THE EXPRESS WRITTEN APPROVAL OF THE PRESIDENT OF NATIONAL SEMICONDUCTOR CORPORATION. As used herein:

1. Life support devices or systems are devices or systems which, (a) are intended for surgical implant into the body, or (b) support or sustain life, and whose failure to perform, when properly used in accordance with instructions for use provided in the labeling, can be reasonably expected to result in a significant injury to the user.
2. A critical component is any component of a life support device or system whose failure to perform can be reasonably expected to cause the failure of the life support device or system, or to affect its safety or effectiveness.



National Semiconductor Corporation
 1111 West Bardin Road
 Arlington, TX 76017
 Tel: 1(800) 272-9959
 Fax: 1(800) 737-7018

National Semiconductor Europe
 Fax: (+49) 0-180-530 85 86
 Email: cnjwge@levm2.nsc.com
 Deutsch Tel: (+49) 0-180-530 85 85
 English Tel: (+49) 0-180-532 78 32
 Français Tel: (+49) 0-180-532 93 58
 Italiano Tel: (+49) 0-180-534 16 80

National Semiconductor Hong Kong Ltd.
 13th Floor, Straight Block,
 Ocean Centre, 5 Canton Rd.
 Tsimshatsui, Kowloon
 Hong Kong
 Tel: (852) 2737-1600
 Fax: (852) 2736-9960

National Semiconductor Japan Ltd.
 Tel: 81-043-299-2309
 Fax: 81-043-299-2408

National does not assume any responsibility for use of any circuitry described, no circuit patent licenses are implied and National reserves the right at any time without notice to change said circuitry and specifications.