

DM74LS395 4-Bit Shift Register with TRI-STATE® Outputs

General Description

The LS395 is a 4-bit shift register with TRI-STATE outputs and can operate in either a synchronous parallel load or a serial shift-right mode, as determined by the Select input. An asynchronous active LOW Master Reset (\overline{MR}) input overrides the synchronous operations and clears the register. An active LOW Output Enable (\overline{OE}) input controls the TRI-STATE output buffers, but does not interfere with the other operations. The fourth stage also has a conventional output for linking purposes in multi-stage serial operations.

Features

- Shift right or parallel 4-bit register
- TRI-STATE outputs
- Input clamp diodes limit high speed termination effects
- Fully CMOS and TTL compatible

Connection Diagram

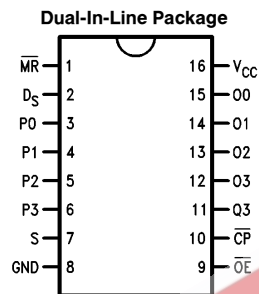

Logic Symbol

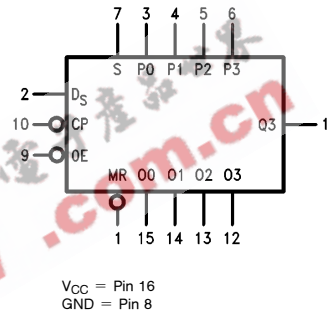



TL/F/9833-2

Order Number **DM74LS395WM** or **DM74LS395N**
See NS Package Number **M16B** or **N16E**

TL/F/9833-1

Mode Select Table

Operating Mode	Inputs @ t_n					Outputs @ t_{n+1}			
	\overline{MR}	\overline{CP}	S	D_S	P_n	O0	O1	O2	O3
Asynchronous Reset	L	X	X	X	X	L	L	L	L
Shift, SET First Stage	H		L	H	X	H	O0 _n	O1 _n	O2 _n
Shift, RESET First Stage	H		L	L	X	L	O0 _n	O1 _n	O2 _n
Parallel Load	H		H	X	P_n	P0	P1	P2	P3

t_n, t_{n+1} = Time before and after CP HIGH-to-LOW transition
H = HIGH Voltage Level
L = LOW Voltage Level
X = Immaterial

Absolute Maximum Ratings (Note)

Supply Voltage	7V
Input Voltage	7V
Operating Free Air Temperature Range	0°C to +70°C
Storage Temperature Range	-65°C to +150°C

Note: The "Absolute Maximum Ratings" are those values beyond which the safety of the device cannot be guaranteed. The device should not be operated at these limits. The parametric values defined in the "Electrical Characteristics" table are not guaranteed at the absolute maximum ratings. The "Recommended Operating Conditions" table will define the conditions for actual device operation.

Recommended Operating Conditions

Symbol	Parameter	Min	Nom	Max	Units
V _{CC}	Supply Voltage	4.75	5	5.25	V
V _{IH}	High Level Input Voltage	2			V
V _{IL}	Low Level Input Voltage			0.8	V
I _{OH}	High Level Output Current			-0.4	mA
I _{OL}	Low Level Output Current			8	mA
T _A	Free Air Operating Temperature	0		70	°C
t _s (H)	Setup Time HIGH or LOW	20			ns
t _s (L)	S, D _S or P _n to CP	20			ns
t _h (H)	Hold Time HIGH or LOW	5			ns
t _h (L)	S, D _S or P _n to \overline{CP}	5			ns
t _w (L)	\overline{CP} Pulse Width LOW	18			ns
t _w (L)	\overline{MR} Pulse Width LOW	20			ns

Electrical Characteristics

 Over recommended operating free air temperature range (unless otherwise noted)

Symbol	Parameter	Conditions	Min	Typ (Note 1)	Max	Units
V _I	Input Clamp Voltage	V _{CC} = Min, I _I = -18 mA			-1.5	V
V _{OH}	High Level Output Voltage	V _{CC} = Min, I _{OH} = Max V _{IL} = Max	2.7			V
V _{OL}	Low Level Output Voltage	V _{CC} = Min, I _{OL} = Max V _{IH} = Min		0.35	0.5	V
		I _{OL} = 4 mA, V _{CC} = Min		0.25	0.4	
I _I	Input Current @ Max Input Voltage	V _{CC} = Max, V _I = 7V			0.1	mA
I _{IH}	High Level Input Current	V _{CC} = Max, V _I = 2.7V			20	μA
I _{IL}	Low Level Input Current	V _{CC} = Max, V _I = 0.4V			-0.4	mA
I _{OS}	Short Circuit Output Current	V _{CC} = Max (Note 2)	-20		-100	mA
I _{CC}	Supply Current with Outputs OFF	V _{CC} = Max, \overline{OE} , D _S , S = 4.5V \overline{CP} = $\overline{}$, P _n = GND			29	mA
	Supply Current with Outputs ON	V _{CC} = Max, D _S , S = 4.5V \overline{OE} , \overline{CP} , P _n = GND			25	mA
I _{OZH}	TRI-STATE Output Off Current HIGH	V _{CC} = V _{CCH} V _{OZH} = 2.7V			20	μA
I _{OZL}	TRI-STATE Output Off Current LOW	V _{CC} = V _{CCH} V _{OZL} = 0.4V			-20	μA

Note 1: All typicals are at V_{CC} = 5V, T_A = 25°C.

Note 2: Not more than one output should be shorted at a time, and the duration should not exceed one second.

Switching Characteristics

$V_{CC} = +5.0V, T_A = +25^\circ C$

Symbol	Parameter	$R_L = 2\text{ k}\Omega, C_L = 15\text{ pF}$		Units
		Min	Max	
f_{max}	Maximum Shift Frequency	30		MHz
t_{PLH} t_{PHL}	Propagation Delay \overline{CP} to O_n		35 25	ns
t_{PHL}	Propagation Delay \overline{MR} to O_n		35	ns
t_{PZH} t_{PZL}	Output Enable Time		20 20	ns
t_{PHZ} t_{PLZ}	Output Disable Time		17 23	ns

Functional Description

The 'LS395 contains four D-type edge-triggered flip-flops and auxiliary gating to select a D input either from a Parallel (P_n) input or from the preceding stage. When the Select input is HIGH, the P_n inputs are enabled. A LOW signal in the S input enables the serial inputs for shift-right operations, as indicated in the Truth Table.

State changes are initiated by HIGH-to-LOW transitions on the Clock Pulse (\overline{CP}) input. Signals on the P_n , D_S and S inputs can change when the Clock is in either state, provided that the recommended setup and hold times are ob-

served. When the S input is LOW, a \overline{CP} HIGH-LOW transition transfers data in O_0 to O_1 , O_1 to O_2 , and O_2 to O_3 . A left-shift is accomplished by connecting the outputs back to the P_n inputs, but offset one place to the left, i.e., O_3 to P_2 , O_2 to P_1 , and O_1 to P_0 , with P_3 acting as the linking input from another package.

When the \overline{OE} input is HIGH, the output buffers are disabled and the O_0 – O_3 outputs are in a high impedance condition. The shifting, parallel loading or resetting operations can still be accomplished, however.

Logic Diagram

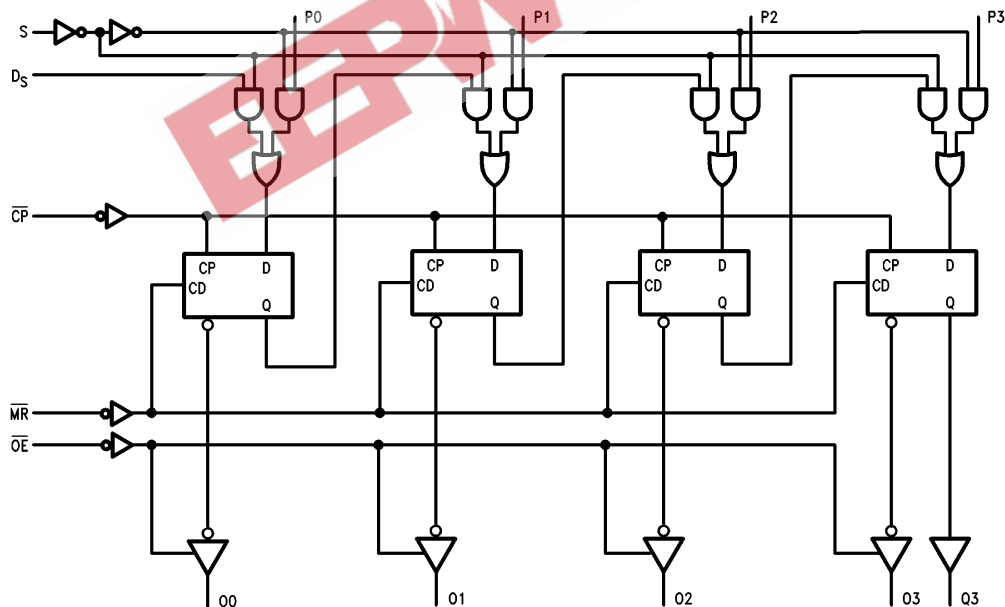

EEPW 电子产品世界
.com.cn

Physical Dimensions inches (millimeters)

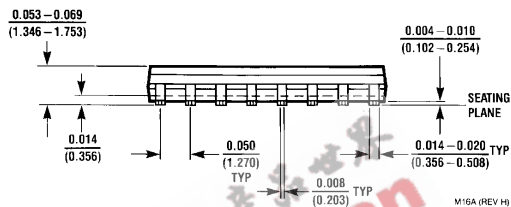
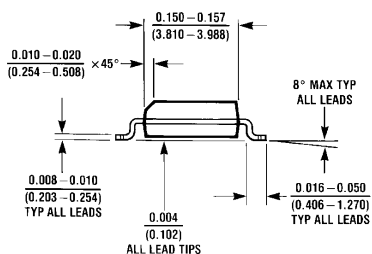
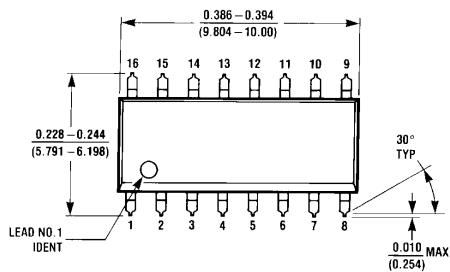

16-Lead Wide Small Outline Molded Package (M)
Order Number DM74LS395WM
NS Package Number M16B

M16A (REV H)

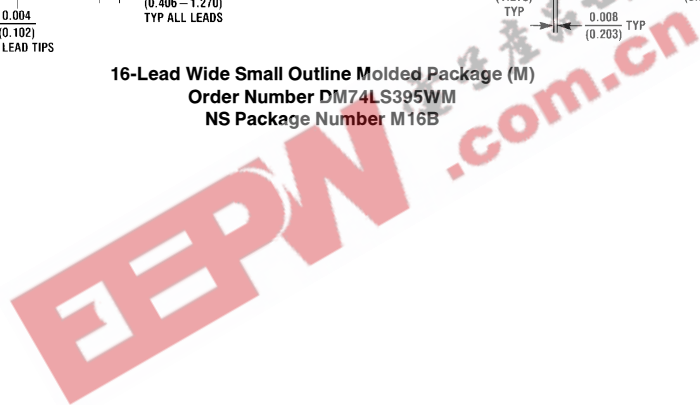

Physical Dimensions inches (millimeters) (Continued)

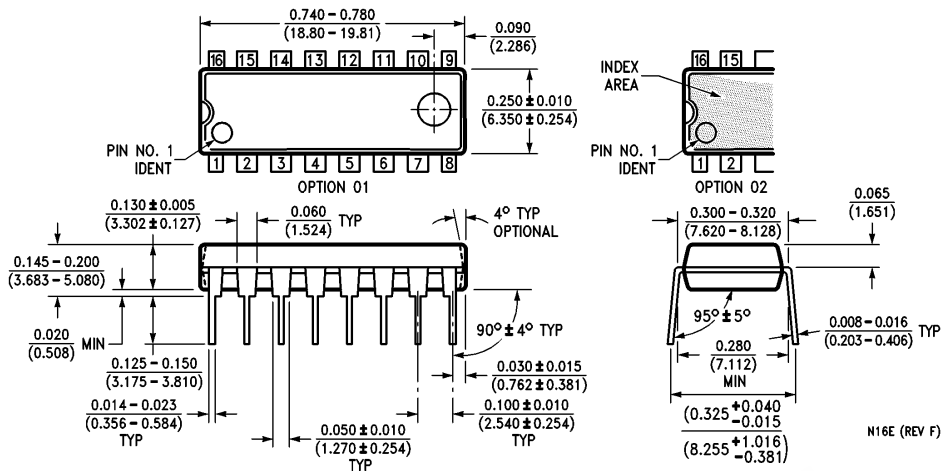

16-Lead Molded Dual-In-Line Package (N)
Order Number DM74LS395N
NS Package Number N16E



LIFE SUPPORT POLICY

NATIONAL'S PRODUCTS ARE NOT AUTHORIZED FOR USE AS CRITICAL COMPONENTS IN LIFE SUPPORT DEVICES OR SYSTEMS WITHOUT THE EXPRESS WRITTEN APPROVAL OF THE PRESIDENT OF NATIONAL SEMICONDUCTOR CORPORATION. As used herein:

1. Life support devices or systems are devices or systems which, (a) are intended for surgical implant into the body, or (b) support or sustain life, and whose failure to perform, when properly used in accordance with instructions for use provided in the labeling, can be reasonably expected to result in a significant injury to the user.
2. A critical component is any component of a life support device or system whose failure to perform can be reasonably expected to cause the failure of the life support device or system, or to affect its safety or effectiveness.



National Semiconductor Corporation
 1111 West Bardin Road
 Arlington, TX 76017
 Tel: 1(800) 272-9959
 Fax: 1(800) 737-7018

National Semiconductor Europe
 Fax: (+49) 0-180-530 85 86
 Email: cnjwge@levm2.nsc.com
 Deutsch Tel: (+49) 0-180-530 85 85
 English Tel: (+49) 0-180-532 78 32
 Français Tel: (+49) 0-180-532 93 58
 Italiano Tel: (+49) 0-180-534 16 80

National Semiconductor Hong Kong Ltd.
 13th Floor, Straight Block,
 Ocean Centre, 5 Canton Rd.
 Tsimshatsui, Kowloon
 Hong Kong
 Tel: (852) 2737-1600
 Fax: (852) 2736-9960

National Semiconductor Japan Ltd.
 Tel: 81-043-299-2309
 Fax: 81-043-299-2408