

# DATA SHEET

EEPW 电子產品世界  
.com.cn

## 74LVC163

Presettable synchronous 4-bit binary counter; synchronous reset

Product specification  
Supersedes data of 1996 Aug 23  
IC24 Data Handbook

1998 May 20

# Presettable synchronous 4-bit binary counter; synchronous reset

## 74LVC163

### FEATURES

- Wide supply voltage range of 1.2 V to 3.6 V
- In accordance with JEDEC standard no. 8–1A
- Inputs accept voltages up to 5.5 V
- CMOS low power consumption
- Direct interface with TTL levels
- Synchronous reset
- Synchronous counting and loading
- Two count enable inputs for n-bit cascading
- Positive edge-triggered clock

### DESCRIPTION

The 74LVC163 is a high-performance, low-power, low-voltage, Si-gate CMOS device and superior to most advanced CMOS compatible TTL families.

The 74LVC163 is a synchronous presettable binary counter which features an internal look-ahead carry and can be used for high-speed counting. Synchronous operation is provided by having all flip-flops clocked simultaneously on the positive-going edge of the clock (CP). The outputs ( $Q_0$  to  $Q_3$ ) of the counters may be preset to a HIGH or LOW level. A LOW level at the parallel enable input (PE) disables the counting action and causes the data at the data inputs ( $D_0$  to  $D_3$ ) to be loaded into the counter on the positive-going edge of the clock (provided that the set-up and hold time requirements for PE are met). Preset takes place regardless of the levels at count enable inputs (CEP and CET). A low level at the master reset input (MR) sets all four outputs of the flip-flops ( $Q_0$  to  $Q_3$ ) to LOW level after the next positive-going transition on the clock (CP) input (provided that the set-up and hold time requirements for PE are met).

This action occurs regardless of the levels at CP,  $\overline{PE}$ , CET and CEP inputs. This synchronous reset feature enables the designer to modify the maximum count with only one external NAND gate.

The look-ahead carry simplifies serial cascading of the counters. Both count enable inputs (CEP and CET) must be HIGH to count. The CET input is fed forward to enable the terminal count output (TC). The TC output thus enabled will produce a HIGH output pulse of a duration approximately equal to a HIGH level output of  $Q_0$ . This pulse can be used to enable the next cascaded stage. The maximum clock frequency for the cascaded counters is determined by the CP to TC propagation delay and CEP to CP set-up time, according to the following formula:

$$f_{\max} = \frac{1}{t_{p(\max)}(\text{CP to TC}) + t_{\text{SU}}(\text{CEP to CP})}$$

### QUICK REFERENCE DATA

GND = 0V;  $T_{\text{amb}} = 25^\circ\text{C}$ ;  $T_{\text{R}} = T_{\text{F}} \leq 2.5\text{ns}$

SYMBOL	PARAMETER	CONDITIONS	TYPICAL	UNIT
$t_{\text{PHL}}/t_{\text{PLH}}$	Propagation delay CP to $Q_n$ CP to TC CET to TC	$C_L = 50\text{ pF}$ $V_{\text{CC}} = 3.3\text{V}$	4.9 5.7 4.5	ns
$f_{\text{MAX}}$	maximum clock frequency		200	MHz
$C_1$	input capacitance		5.0	pF
$C_{\text{PD}}$	power dissipation capacitance per gate	notes 1 and 2	39	pF

#### NOTES:

1.  $C_{\text{PD}}$  is used to determine the dynamic power dissipation ( $P_{\text{D}}$  in  $\mu\text{W}$ )  
 $P_{\text{D}} = C_{\text{PD}} \times V_{\text{CC}}^2 \times f_i + \sum (C_L \times V_{\text{CC}}^2 \times f_o)$  where:  
 $f_i$  = input frequency in MHz;  $C_L$  = output load capacity in pF;  
 $f_o$  = output frequency in MHz;  $V_{\text{CC}}$  = supply voltage in V;  
 $\sum (C_L \times V_{\text{CC}}^2 \times f_o)$  = sum of the outputs
2. The condition is  $V_1 = \text{GND to } V_{\text{CC}}$

### ORDERING INFORMATION

PACKAGES	TEMPERATURE RANGE	OUTSIDE NORTH AMERICA	NORTH AMERICA	DWG NUMBER
16-Pin Plastic SO	$-40^\circ\text{C to } +85^\circ\text{C}$	74LVC163 D	74LVC163 D	SOT109-1
16-Pin Plastic SSOP Type II	$-40^\circ\text{C to } +85^\circ\text{C}$	74LVC163 DB	74LVC163 DB	SOT338-1
16-Pin Plastic TSSOP Type I	$-40^\circ\text{C to } +85^\circ\text{C}$	74LVC163 PW	74LVC163PW DH	SOT403-1

Pre-settable synchronous 4-bit binary counter;  
synchronous reset

74LVC163

PIN CONFIGURATION

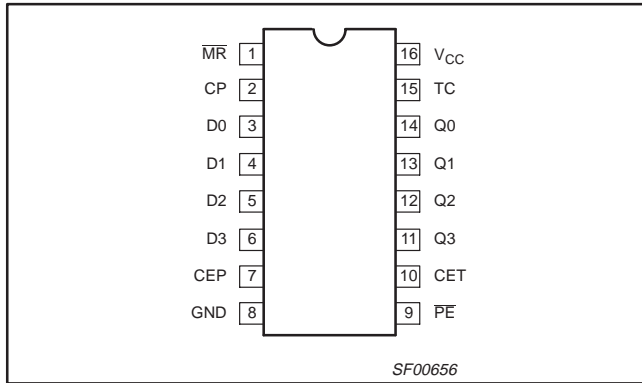

PIN DESCRIPTION

PIN NUMBER	SYMBOL	FUNCTION
1	$\overline{MR}$	asynchronous master reset (active LOW)
2	CP	clock input (LOW-to-HIGH, edge-triggered)
3,4,5,6	D <sub>0</sub> to D <sub>3</sub>	data inputs
7	CEP	count enable inputs
8	GND	ground (0V)
9	$\overline{PE}$	parallel enable input (active LOW)
10	CET	count enable carry input
14,13,12,11	Q <sub>0</sub> to Q <sub>3</sub>	flip-flop outputs
15	TC	terminal count output
16	V <sub>CC</sub>	positive supply voltage

LOGIC SYMBOL

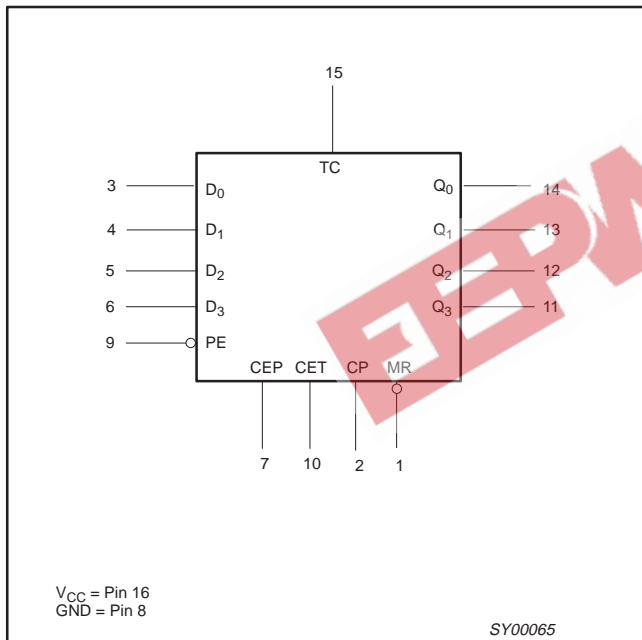

LOGIC SYMBOL (IEEE/IEC)

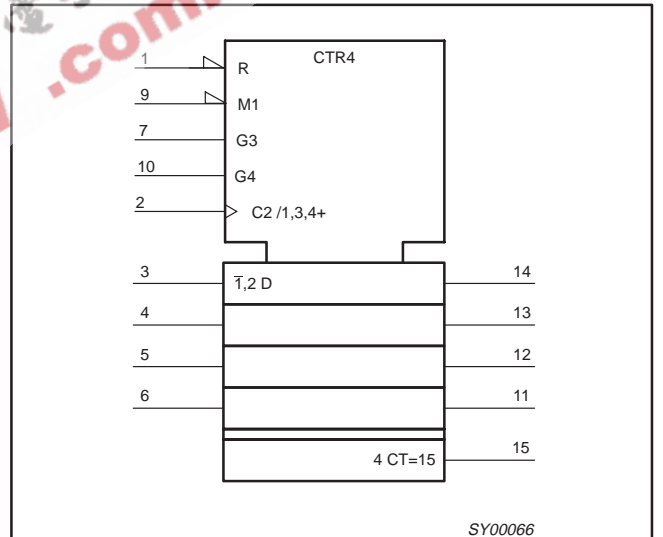

# Pre-settable synchronous 4-bit binary counter; synchronous reset

74LVC163

## FUNCTIONAL DIAGRAM

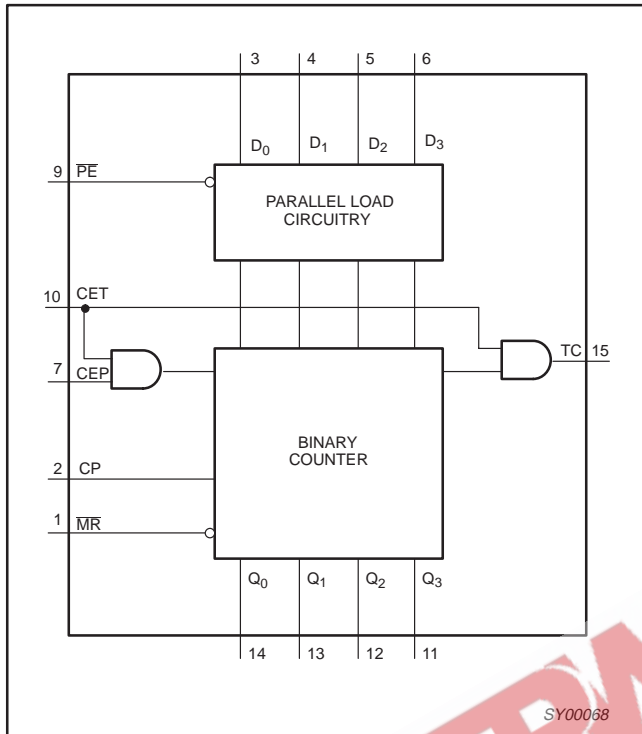

## FUNCTION TABLE

OPERATING MODES	INPUTS						OUTPUTS	
	MR	CP	CEP	CET	PE	Dn	Qn	TC
Reset (clear)	l	↑	X	X	X	X	L	L
Parallel load	h	↑	X	X	l	l	L	L
	h	↑	X	X	l	h	H	*
Count	h	↑	h	h	h	X	count	*
Hold (do nothing)	h	X	l	X	h	X	qn	*
	h	X	X	l	h	X	qn	L

### NOTES:

- \* = The TC output is High when CET is High and the counter is at Terminal Count (HHHH)
- H = High voltage level
- h = High voltage level one setup time prior to the Low-to-High clock transition
- L = Low voltage level
- l = Low voltage level one setup time prior to the Low-to-High clock transition
- q = Lower case letters indicate the state of the referenced output one setup time prior to the Low-to-High clock transition
- X = Don't care
- ↑ = Low-to-High clock transition

## TYPICAL TIMING SEQUENCE

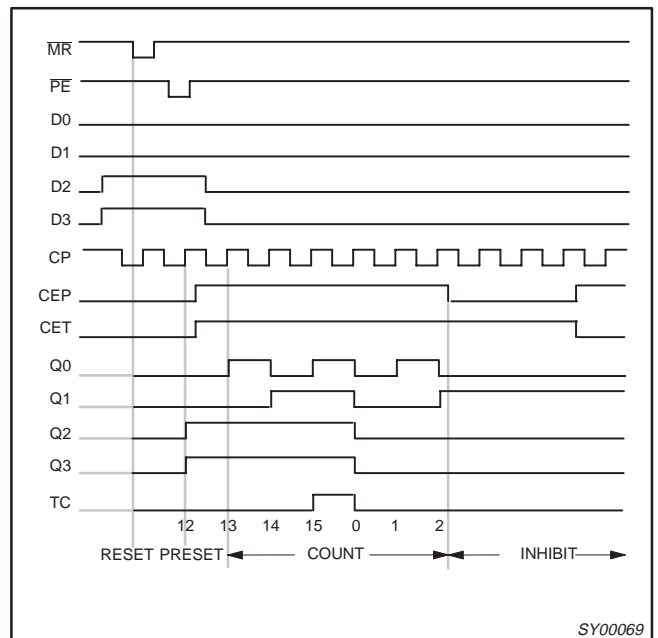

## STATE DIAGRAM

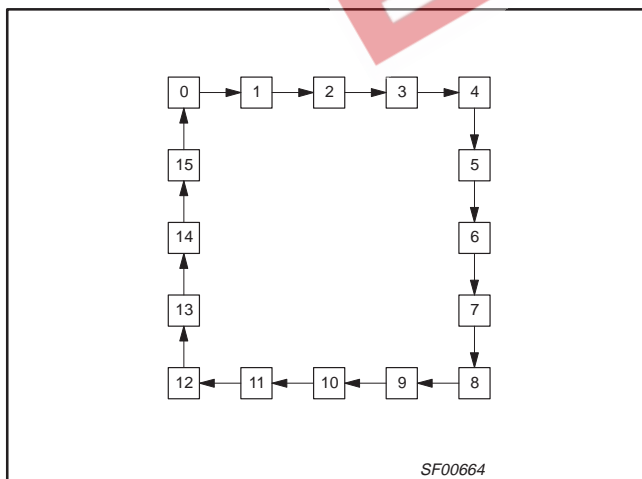

Typical timing sequence: reset outputs to zero; preset to binary twelve; count to thirteen, fourteen, fifteen, zero, one, and two; inhibit

# Pre-settable synchronous 4-bit binary counter; synchronous reset

74LVC163

## LOGIC DIAGRAM

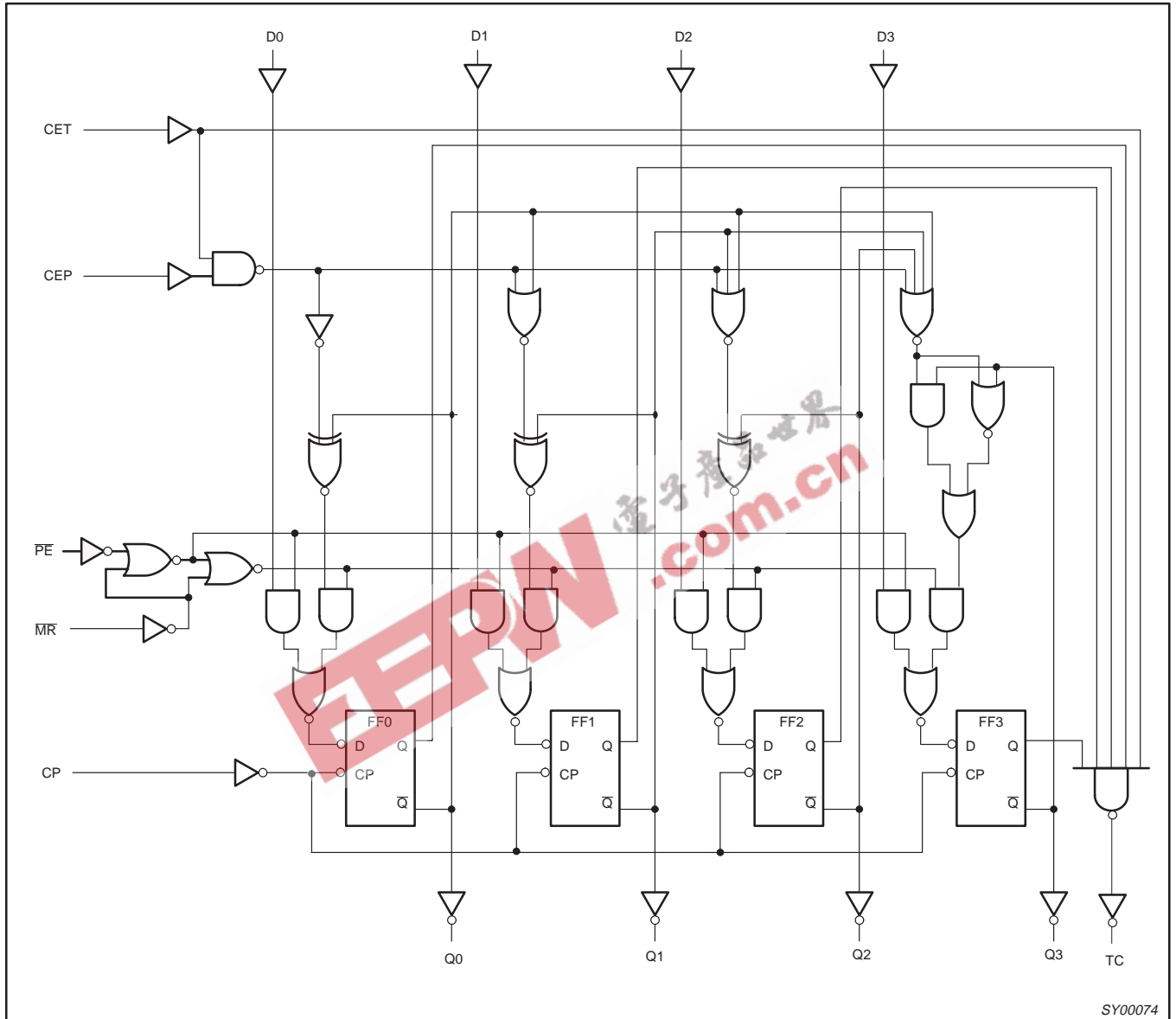

# Pre-settable synchronous 4-bit binary counter; synchronous reset

74LVC163

## RECOMMENDED OPERATING CONDITIONS

SYMBOL	PARAMETER	CONDITIONS	LIMITS		UNIT
			MIN	MAX	
$V_{CC}$	DC supply voltage (for max. speed performance)		2.7	3.6	V
	DC supply voltage (for low-voltage applications)		1.2	3.6	
$V_I$	DC input voltage range		0	5.5	V
$V_O$	DC output voltage range		0	$V_{CC}$	V
$T_{amb}$	Operating free-air temperature range		-40	+85	°C
$t_r, t_f$	Input rise and fall times	$V_{CC} = 1.2$ to $2.7V$	0	20	ns/V
		$V_{CC} = 2.7$ to $3.6V$	0	10	

## ABSOLUTE MAXIMUM RATINGS<sup>1</sup>

In accordance with the Absolute Maximum Rating System (IEC 134)  
Voltages are referenced to GND (ground = 0V)

SYMBOL	PARAMETER	CONDITIONS	RATING	UNIT
$V_{CC}$	DC supply voltage		-0.5 to +6.5	V
$I_{IK}$	DC input diode current	$V_I < 0$	-50	mA
$V_I$	DC input voltage	Note 2	-0.5 to +5.5	V
$I_{OK}$	DC output diode current	$V_O > V_{CC}$ or $V_O < 0$	$\pm 50$	mA
$V_O$	DC output voltage	Note 2	-0.5 to $V_{CC} + 0.5$	V
$I_O$	DC output source or sink current	$V_O = 0$ to $V_{CC}$	$\pm 50$	mA
$I_{GND}, I_{CC}$	DC $V_{CC}$ or GND current		$\pm 100$	mA
$T_{stg}$	Storage temperature range		-65 to +150	°C
$P_{TOT}$	Power dissipation per package – plastic mini-pack (SO) – plastic shrink mini-pack (SSOP and TSSOP)	above +70°C derate linearly with 8 mW/K	500	mW
		above +60°C derate linearly with 5.5 mW/K	500	

### NOTES:

- Stresses beyond those listed may cause permanent damage to the device. These are stress ratings only and functional operation of the device at these or any other conditions beyond those indicated under "recommended operating conditions" is not implied. Exposure to absolute-maximum-rated conditions for extended periods may affect device reliability.
- The input and output voltage ratings may be exceeded if the input and output current ratings are observed.

# Pre-settable synchronous 4-bit binary counter; synchronous reset

74LVC163

## DC ELECTRICAL CHARACTERISTICS

Over recommended operating conditions voltages are referenced to GND (ground = 0V)

SYMBOL	PARAMETER	TEST CONDITIONS	LIMITS			UNIT
			Temp = -40°C to +85°C			
			MIN	TYP <sup>1</sup>	MAX	
V <sub>IH</sub>	HIGH level Input voltage	V <sub>CC</sub> = 1.2V	V <sub>CC</sub>			V
		V <sub>CC</sub> = 2.7 to 3.6V	2.0			
V <sub>IL</sub>	LOW level Input voltage	V <sub>CC</sub> = 1.2V			GND	V
		V <sub>CC</sub> = 2.7 to 3.6V			0.8	
V <sub>OH</sub>	HIGH level output voltage	V <sub>CC</sub> = 2.7V; V <sub>I</sub> = V <sub>IH</sub> or V <sub>IL</sub> ; I <sub>O</sub> = -12mA	V <sub>CC</sub> - 0.5			V
		V <sub>CC</sub> = 3.0V; V <sub>I</sub> = V <sub>IH</sub> or V <sub>IL</sub> ; I <sub>O</sub> = -100µA	V <sub>CC</sub> - 0.2	V <sub>CC</sub>		
		V <sub>CC</sub> = 3.0V; V <sub>I</sub> = V <sub>IH</sub> or V <sub>IL</sub> ; I <sub>O</sub> = -12mA	V <sub>CC</sub> - 0.6			
		V <sub>CC</sub> = 3.0V; V <sub>I</sub> = V <sub>IH</sub> or V <sub>IL</sub> ; I <sub>O</sub> = -24mA	V <sub>CC</sub> - 1.0			
V <sub>OL</sub>	LOW level output voltage	V <sub>CC</sub> = 2.7V; V <sub>I</sub> = V <sub>IH</sub> or V <sub>IL</sub> ; I <sub>O</sub> = 12mA			0.40	V
		V <sub>CC</sub> = 3.0V; V <sub>I</sub> = V <sub>IH</sub> or V <sub>IL</sub> ; I <sub>O</sub> = 100µA		GND	0.20	
		V <sub>CC</sub> = 3.0V; V <sub>I</sub> = V <sub>IH</sub> or V <sub>IL</sub> ; I <sub>O</sub> = 24mA			0.55	
I <sub>I</sub>	Input leakage current	V <sub>CC</sub> = 3.6V; V <sub>I</sub> = 5.5V or GND		±0.1	±5	µA
I <sub>CC</sub>	Quiescent supply current	V <sub>CC</sub> = 3.6V; V <sub>I</sub> = V <sub>CC</sub> or GND; I <sub>O</sub> = 0		0.1	10	µA
ΔI <sub>CC</sub>	Additional quiescent supply current per input pin	V <sub>CC</sub> = 2.7V to 3.6V; V <sub>I</sub> = V <sub>CC</sub> - 0.6V; I <sub>O</sub> = 0		5	500	µA

### NOTES:

1. All typical values are at V<sub>CC</sub> = 3.3V and T<sub>amb</sub> = 25°C.

## AC CHARACTERISTICS

GND = 0 V; t<sub>r</sub> = t<sub>f</sub> ≤ 2.5 ns; C<sub>L</sub> = 50 pF; R<sub>L</sub> = 500Ω; T<sub>amb</sub> = -40°C to +85°C

SYMBOL	PARAMETER	WAVEFORM	LIMITS						UNIT
			V <sub>CC</sub> = 3.3V ±0.3V			V <sub>CC</sub> = 2.7V		V <sub>CC</sub> = 1.2V	
			MIN	TYP <sup>1</sup>	MAX	MIN	MAX	TYP	
t <sub>pHL</sub> t <sub>pLH</sub>	Propagation delay CP to Q <sub>n</sub>	1	-	4.9	8.0	-	9.0	24	ns
t <sub>pHL</sub> t <sub>pLH</sub>	Propagation delay CP to TC	1	-	5.7	9.5	-	11	28	ns
t <sub>pHL</sub> t <sub>pLH</sub>	Propagation delay CET to TC	2	-	4.5	7.8	-	8.8	19	ns
t <sub>w</sub>	Clock pulse width HIGH or LOW	1	4.0	1.2	-	5.0	-	-	ns
t <sub>su</sub>	Set-up time D <sub>n</sub> to CP	3, 4	2.5	1.0	-	3.0	-	-	ns
t <sub>su</sub>	Set-up time MR, PE to CP	4	3.0	1.2	-	3.5	-	-	ns
t <sub>su</sub>	Set-up time CEP, CET to CP	5	5.0	2.1	-	5.5	-	-	ns
t <sub>h</sub>	Hold time D <sub>n</sub> , PE, CEP, CET, MR to CP	3, 4, and 5	0	-1.7	-	0	-	-	ns
f <sub>max</sub>	Maximum clock pulse frequency	1	125	200	-	110	-	-	MHz

### NOTE:

1. These typical values are at V<sub>CC</sub> = 3.3V and T<sub>amb</sub> = 25°C.

# Pre-settable synchronous 4-bit binary counter; synchronous reset

74LVC163

### AC WAVEFORMS

$V_M = 1.5\text{ V}$  at  $V_{CC} \geq 2.7\text{ V}$

$V_M = 0.5 \cdot V_{CC}$  at  $V_{CC} < 2.7\text{ V}$

$V_{OL}$  and  $V_{OH}$  are the typical output voltage drop that occur with the output load.

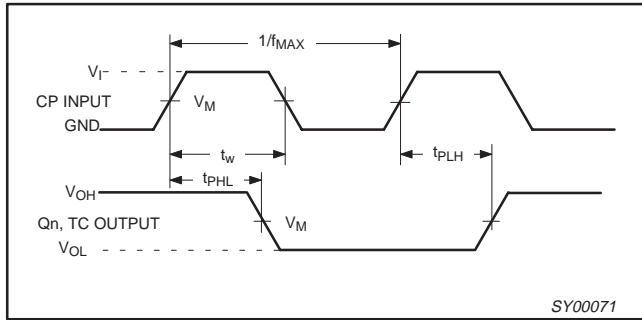

**Waveform 1.** Clock (CP) to outputs ( $Q_n$ , TC) propagation delays, the clock pulse width and the maximum clock frequency.

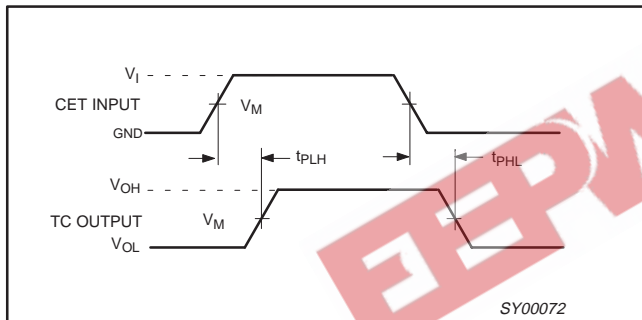

**Waveform 2.** Input (CET) to output (TC) propagation delays.

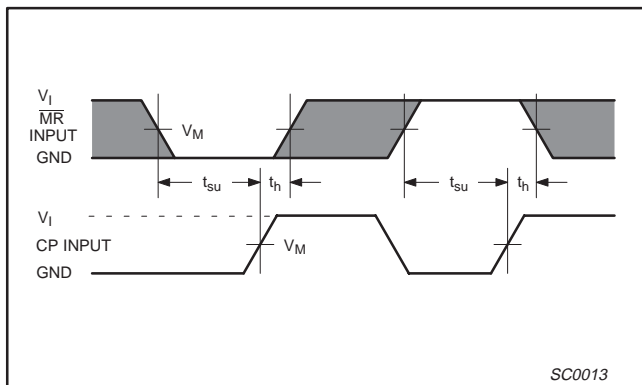

**Waveform 3.** Master reset ( $\overline{MR}$ ) pulse width, the master reset to output ( $Q_n$ , TC) propagation delays and the master reset to clock (CP) removal times.

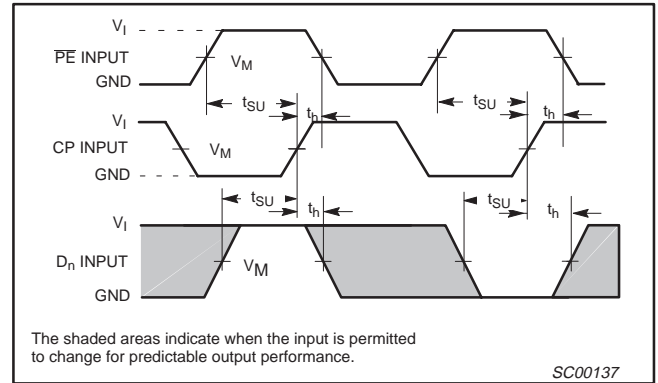

**Waveform 4.** Setup and hold times for the input ( $D_n$ ) and parallel enable input ( $\overline{PE}$ ).

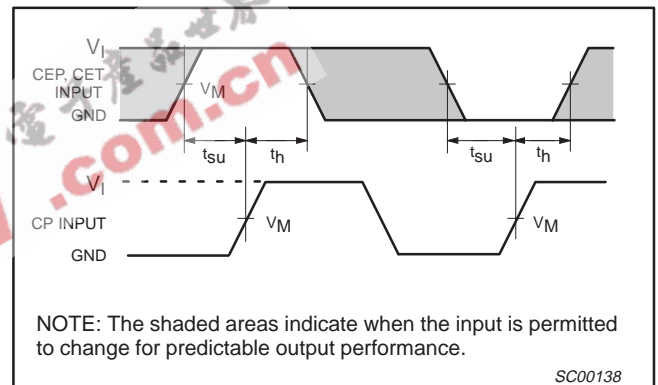

**Waveform 5.** CEP and CET setup and hold times.

### TEST CIRCUIT

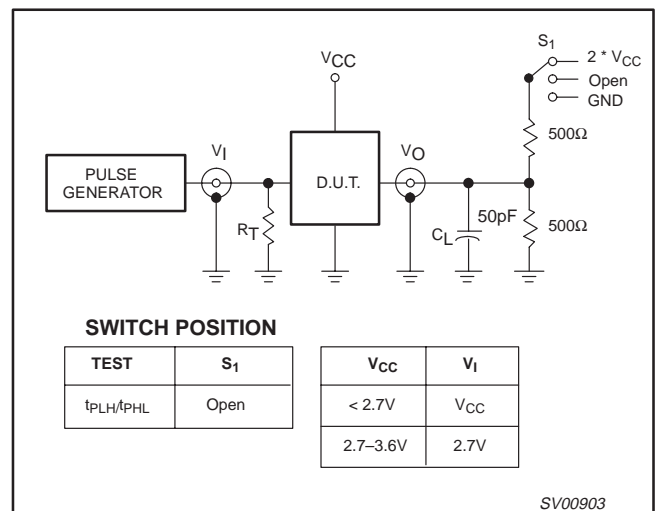

**Waveform 6.** Load circuitry for switching times.



Presettable synchronous 4-bit binary counter;  
synchronous reset

74LVC163

SO16: plastic small outline package; 16 leads; body width 3.9 mm

SOT109-1

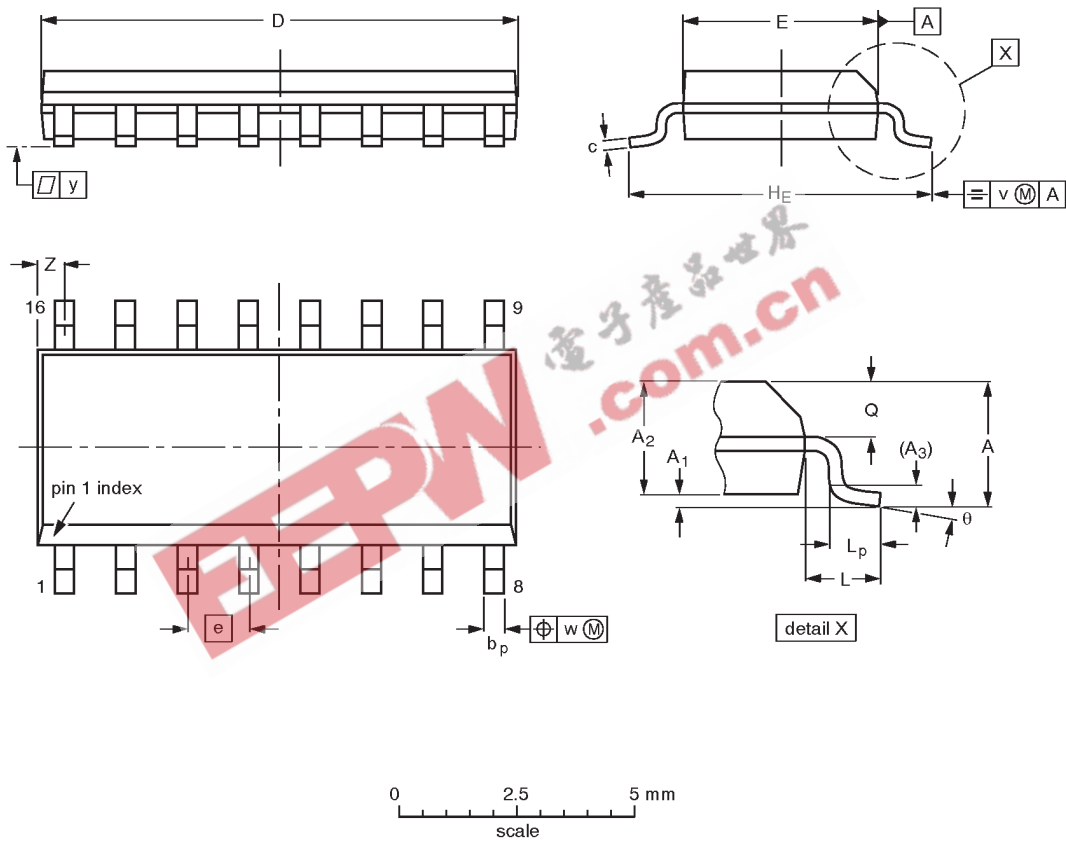

DIMENSIONS (inch dimensions are derived from the original mm dimensions)

UNIT	A max.	A <sub>1</sub>	A <sub>2</sub>	A <sub>3</sub>	b <sub>p</sub>	c	D <sup>(1)</sup>	E <sup>(1)</sup>	e	H <sub>E</sub>	L	L <sub>p</sub>	Q	v	w	y	Z <sup>(1)</sup>	$\theta$
mm	1.75	0.25 0.10	1.45 1.25	0.25	0.49 0.36	0.25 0.19	10.0 9.8	4.0 3.8	1.27	6.2 5.8	1.05	1.0 0.4	0.7 0.6	0.25	0.25	0.1	0.7 0.3	8° 0°
inches	0.069	0.0098 0.0039	0.057 0.049	0.01	0.019 0.014	0.0098 0.0075	0.39 0.38	0.16 0.15	0.050	0.24 0.23	0.041	0.039 0.016	0.028 0.020	0.01	0.01	0.004	0.028 0.012	

Note

1. Plastic or metal protrusions of 0.15 mm maximum per side are not included.

OUTLINE VERSION	REFERENCES				EUROPEAN PROJECTION	ISSUE DATE
	IEC	JEDEC	EIAJ			
SOT109-1	076E07S	MS-012AC				91-08-13 95-01-23

Presettable synchronous 4-bit binary counter;  
synchronous reset

74LVC163

SSOP16: plastic shrink small outline package; 16 leads; body width 5.3 mm

SOT338-1

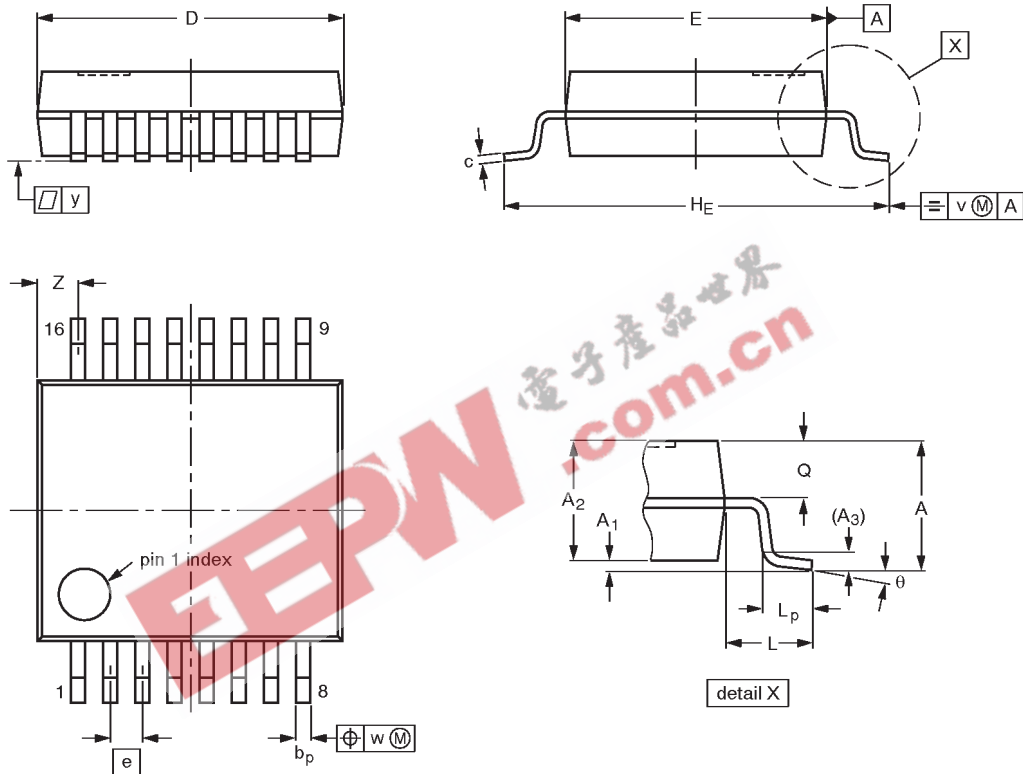

DIMENSIONS (mm are the original dimensions)

UNIT	A max.	A <sub>1</sub>	A <sub>2</sub>	A <sub>3</sub>	b <sub>p</sub>	c	D <sup>(1)</sup>	E <sup>(1)</sup>	e	H <sub>E</sub>	L	L <sub>p</sub>	Q	v	w	y	z <sup>(1)</sup>	θ
mm	2.0	0.21 0.05	1.80 1.65	0.25	0.38 0.25	0.20 0.09	6.4 6.0	5.4 5.2	0.65	7.9 7.6	1.25	1.03 0.63	0.9 0.7	0.2	0.13	0.1	1.00 0.55	8° 0°

Note

1. Plastic or metal protrusions of 0.25 mm maximum per side are not included.

OUTLINE VERSION	REFERENCES				EUROPEAN PROJECTION	ISSUE DATE
	IEC	JEDEC	EIAJ			
SOT338-1		MO-150AC				94-01-14 95-02-04

Pre-settable synchronous 4-bit binary counter;  
synchronous reset

74LVC163

TSSOP16: plastic thin shrink small outline package; 16 leads; body width 4.4 mm

SOT403-1

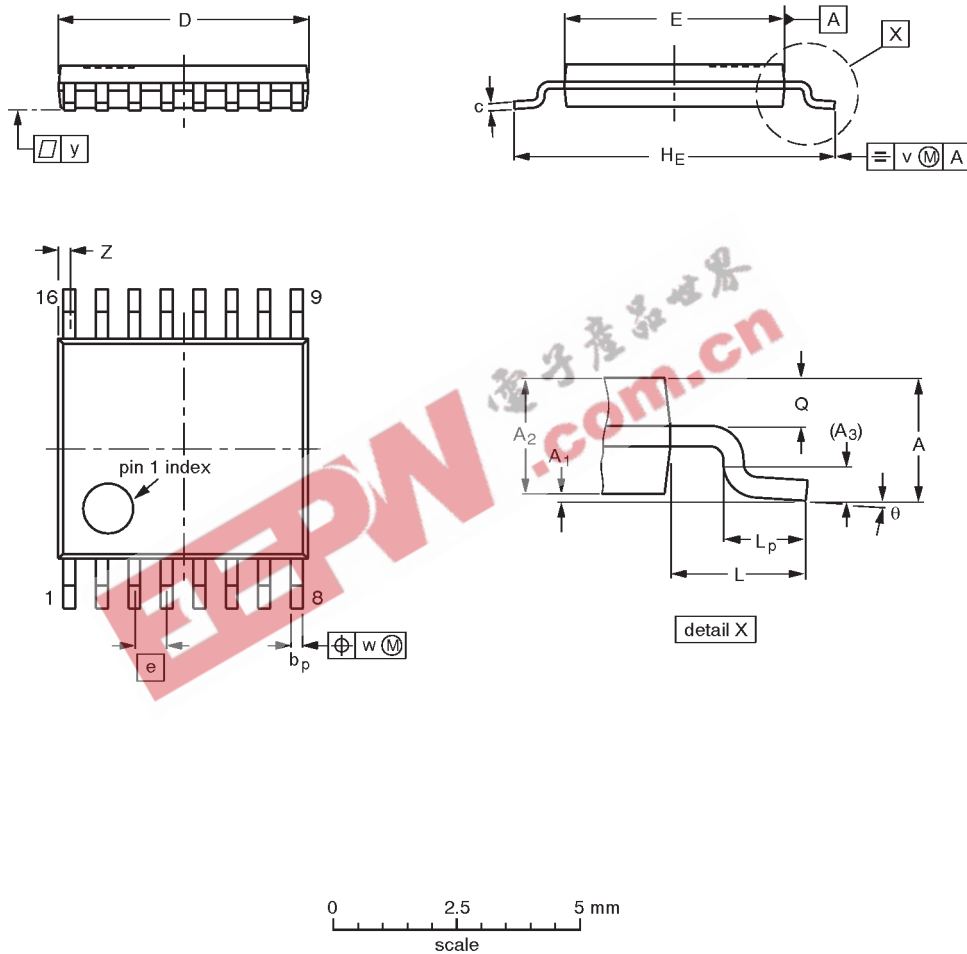

**DIMENSIONS (mm are the original dimensions)**

UNIT	A max.	A <sub>1</sub>	A <sub>2</sub>	A <sub>3</sub>	b <sub>p</sub>	c	D <sup>(1)</sup>	E <sup>(2)</sup>	e	H <sub>E</sub>	L	L <sub>p</sub>	Q	v	w	y	z <sup>(1)</sup>	θ
mm	1.10	0.15 0.05	0.95 0.80	0.25	0.30 0.19	0.2 0.1	5.1 4.9	4.5 4.3	0.65	6.6 6.2	1.0	0.75 0.50	0.4 0.3	0.2	0.13	0.1	0.40 0.06	8° 0°

**Notes**

1. Plastic or metal protrusions of 0.15 mm maximum per side are not included.
2. Plastic interlead protrusions of 0.25 mm maximum per side are not included.

OUTLINE VERSION	REFERENCES				EUROPEAN PROJECTION	ISSUE DATE
	IEC	JEDEC	EIAJ			
SOT403-1		MO-153				94-07-12 95-04-04

# Presetable synchronous 4-bit binary counter; synchronous reset

74LVC163

## DEFINITIONS

Data Sheet Identification	Product Status	Definition
<i>Objective Specification</i>	<b>Formative or in Design</b>	This data sheet contains the design target or goal specifications for product development. Specifications may change in any manner without notice.
<i>Preliminary Specification</i>	<b>Preproduction Product</b>	This data sheet contains preliminary data, and supplementary data will be published at a later date. Philips Semiconductors reserves the right to make changes at any time without notice in order to improve design and supply the best possible product.
<i>Product Specification</i>	<b>Full Production</b>	This data sheet contains Final Specifications. Philips Semiconductors reserves the right to make changes at any time without notice, in order to improve design and supply the best possible product.

Philips Semiconductors and Philips Electronics North America Corporation reserve the right to make changes, without notice, in the products, including circuits, standard cells, and/or software, described or contained herein in order to improve design and/or performance. Philips Semiconductors assumes no responsibility or liability for the use of any of these products, conveys no license or title under any patent, copyright, or mask work right to these products, and makes no representations or warranties that these products are free from patent, copyright, or mask work right infringement, unless otherwise specified. Applications that are described herein for any of these products are for illustrative purposes only. Philips Semiconductors makes no representation or warranty that such applications will be suitable for the specified use without further testing or modification.

### LIFE SUPPORT APPLICATIONS

Philips Semiconductors and Philips Electronics North America Corporation Products are not designed for use in life support appliances, devices, or systems where malfunction of a Philips Semiconductors and Philips Electronics North America Corporation Product can reasonably be expected to result in a personal injury. Philips Semiconductors and Philips Electronics North America Corporation customers using or selling Philips Semiconductors and Philips Electronics North America Corporation Products for use in such applications do so at their own risk and agree to fully indemnify Philips Semiconductors and Philips Electronics North America Corporation for any damages resulting from such improper use or sale.

**Philips Semiconductors**  
811 East Arques Avenue  
P.O. Box 3409  
Sunnyvale, California 94088-3409  
Telephone 800-234-7381

Philips Semiconductors and Philips Electronics North America Corporation register eligible circuits under the Semiconductor Chip Protection Act.  
© Copyright Philips Electronics North America Corporation 1998  
All rights reserved. Printed in U.S.A.

print code

Date of release: 05-96

Document order number:

9397-750-04497

*Let's make things better.*