

Document No.	853-1486
ECN No.	00730
Date of Issue	October 17, 1990
Status	Product Specification
ACL Products	

# AC11013: Product Specification

## ACT11013: Objective Specification

### Dual 4-input NAND Schmitt-trigger

#### FEATURES

- Output capability:  $\pm 24$  mA
- CMOS (AC) and TTL (ACT) voltage level inputs
- 50 $\Omega$  incident wave switching
- Center-pin  $V_{CC}$  and ground configuration to minimize high-speed switching noise
- $I_{CC}$  category: SSI

#### DESCRIPTION

The 74AC/ACT11013 high-performance CMOS devices combine very high speed and high output drive comparable to the most advanced TTL families.

The 74AC/ACT11013 provides two separate 4-input NAND gate functions which are capable of transforming slowly changing input signals into sharply defined, jitter-free output signals. In addition, they have greater noise margin than conventional NAND gates.

#### QUICK REFERENCE DATA

SYMBOL	PARAMETER	CONDITIONS $T_{amb} = 25^{\circ}C$ ; GND = 0V; $V_{CC} = 5.0V$	TYPICAL		UNIT
			AC	ACT	
$t_{PLH}/t_{PHL}$	Propagation delay A, B, C, D to Y	$C_L = 50pF$	4.3	8.0	ns
$C_{PD}$	Power dissipation capacitance, per gate <sup>1</sup>	$f = 1MHz$ ; $C_L = 50pF$	29	32	pF
$C_{IN}$	Input capacitance	$V_I = 0V$ or $V_{CC}$	3.5	3.5	pF
$I_{LATCH}$	Latch-up current	Per JEDEC JC40.2 Standard 17	500	500	mA

#### Note:

1.  $C_{PD}$  is used to determine the dynamic power dissipation ( $P_D$  in  $\mu W$ ):

$$P_D = C_{PD} \times V_{CC}^2 \times f_I + \sum (C_L \times V_{CC}^2 \times f_O)$$

where:  
 $f_I$  = input frequency in MHz,  $C_L$  = output load capacitance in pF,  
 $f_O$  = output frequency in MHz,  $V_{CC}$  = supply voltage in V,  
 $\sum (C_L \times V_{CC}^2 \times f_O)$  = sum of outputs

#### ORDERING INFORMATION

PACKAGES	TEMPERATURE RANGE	ORDER CODE
14-pin plastic DIP (300mil-wide)	-40°C to +85°C	74AC11013N 74ACT11013N
14-pin plastic SO (150mil-wide)	-40°C to +85°C	74AC11013D 74ACT11013D

#### PIN CONFIGURATION

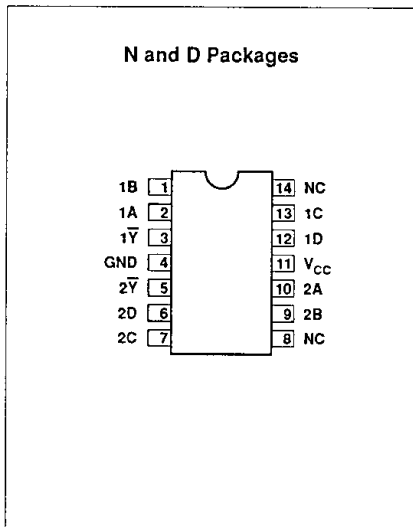

#### LOGIC SYMBOL

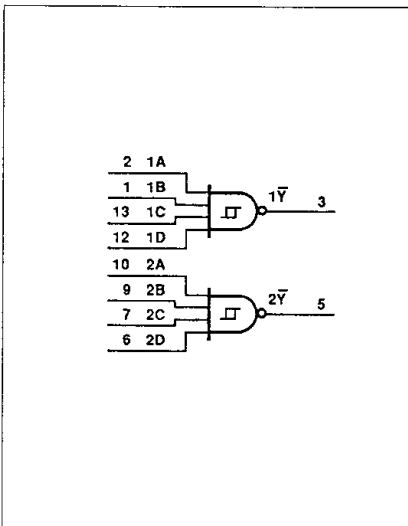

#### LOGIC SYMBOL (IEEE/IEC)

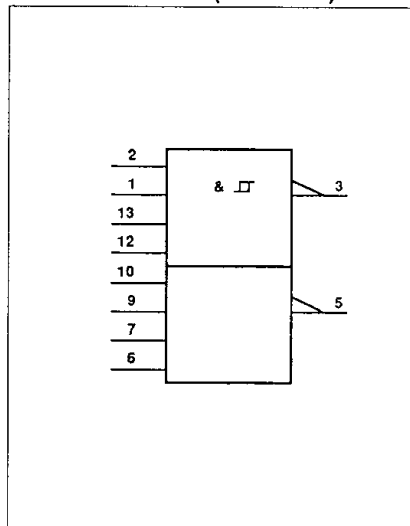

## Dual 4-input NAND Schmitt-trigger

74AC/ACT11013

## PIN DESCRIPTION

PIN NUMBER	SYMBOL	NAME AND FUNCTION
2, 10	1A - 2A	Data inputs
1, 9	1B - 2B	Data inputs
13, 7	1C - 2C	Data inputs
12, 6	1D - 2D	Data inputs
3, 5	1 $\bar{Y}$ - 2 $\bar{Y}$	Data outputs
4	GND	Ground (0V)
11	V <sub>CC</sub>	Positive supply voltage

## FUNCTION TABLE

INPUTS				OUTPUT
nA	nB	nC	nD	n $\bar{Y}$
H	H	H	H	L
L	X	X	X	H
X	L	X	X	H
X	X	L	X	H
X	X	X	L	H

## RECOMMENDED OPERATING CONDITIONS

SYMBOL	PARAMETER	74AC11013			74ACT11013			UNIT
		Min	Nom	Max	Min	Nom	Max	
V <sub>CC</sub>	DC supply voltage	3.0 <sup>1</sup>	5.0	5.5	4.5	5.0	5.5	V
V <sub>I</sub>	Input voltage	0		V <sub>CC</sub>	0		V <sub>CC</sub>	V
V <sub>O</sub>	Output voltage	0		V <sub>CC</sub>	0		V <sub>CC</sub>	V
$\Delta V/\Delta t$	Input transition rise or fall rate	0		100	0		100	ns/V
T <sub>amb</sub>	Operating free-air temperature range	-40		+85	-40		+85	°C

## NOTE:

1. No electrical or switching characteristics are specified at V<sub>CC</sub> < 3V. Operation between 2V and 3V is not recommended, but within that range, a device output will maintain a previously established logic state.

ABSOLUTE MAXIMUM RATINGS<sup>1</sup>

SYMBOL	PARAMETER	TEST CONDITIONS	RATING	UNIT
V <sub>CC</sub>	DC supply voltage		-0.5 TO +7.0	V
I <sub>IK</sub> or V <sub>I</sub>	DC input diode current <sup>2</sup>	V <sub>I</sub> < 0	-20	mA
		V <sub>I</sub> > V <sub>CC</sub>	20	
	DC input voltage		-0.5 to V <sub>CC</sub> +0.5	V
I <sub>OK</sub> or V <sub>O</sub>	DC output diode current <sup>2</sup>	V <sub>O</sub> < 0	-50	mA
		V <sub>O</sub> > V <sub>CC</sub>	50	
	DC output voltage		-0.5 to V <sub>CC</sub> +0.5	V
I <sub>O</sub>	DC output source or sink current per output pin	V <sub>O</sub> = 0 to V <sub>CC</sub>	±50	mA
I <sub>CC</sub> or I <sub>GND</sub>	DC V <sub>CC</sub> current		±100	mA
	DC ground current		±100	
T <sub>STG</sub>	Storage temperature		-65 to 150	°C
P <sub>TOT</sub>	Power dissipation per package	Above 70°C; derate linearly by 8mW/K	500	mW
	Power dissipation per package Plastic surface mount (SO)	Above 70°C; derate linearly by 8mW/K	400	

## NOTES:

1. Stresses beyond those listed may cause permanent damage to the device. These are stress ratings only and functional operation of the device at these or any other conditions beyond those indicated under "recommended operating conditions" is not implied. Exposure to absolute-maximum-rated conditions for extended periods may affect device reliability.

2. The input and output voltage ratings may be exceeded if the input and output current ratings are observed.

## Dual 4-input NAND Schmitt-trigger

74AC/ACT11013

## DC ELECTRICAL CHARACTERISTICS

SYMBOL	PARAMETER	TEST CONDITIONS	V <sub>CC</sub>	74AC11013				74ACT11013				UNIT	
				T <sub>amb</sub> = +25°C		T <sub>amb</sub> = -40°C to +85°C		T <sub>amb</sub> = +25°C		T <sub>amb</sub> = -40°C to +85°C			
				Min	Max	Min	Max	Min	Max	Min	Max		
V <sub>T+</sub>	Positive-going threshold		3.0		2.2		2.2					V	
			4.5		3.2		3.2		2.0		2.0		
			5.5		3.9		3.9		2.0		2.0		
V <sub>T-</sub>	Negative-going threshold		3.0	0.5		0.5						V	
			4.5	0.9		0.9			0.8		0.8		
			5.5	1.1		1.1			0.8		0.8		
ΔV <sub>T</sub>	Hysteresis (V <sub>T+</sub> - V <sub>T-</sub> )		3.0	0.3	1.2	0.3	1.2					V	
			4.5	0.4	1.4	0.4	1.4	0.4	1.2	0.4	1.2		
			5.5	0.5	1.6	0.5	1.6	0.4	1.2	0.4	1.2		
V <sub>IH</sub>	High-level input voltage		3.0	2.10		2.10						V	
			4.5	3.15		3.15			2.0		2.0		
			5.5	3.85		3.85			2.0		2.0		
V <sub>IL</sub>	Low-level input voltage		3.0		0.90		0.90					V	
			4.5		1.35		1.35			0.8	0.8		
			5.5		1.65		1.65			0.8	0.8		
V <sub>OH</sub>	High-level output voltage	V <sub>I</sub> = V <sub>IL</sub> or V <sub>IH</sub>	I <sub>OH</sub> = -50μA	3.0	2.9		2.9					V	
				4.5	4.4		4.4			4.4	4.4		
				5.5	5.4		5.4			5.4	5.4		
				I <sub>OH</sub> = -4mA	3.0	2.58		2.48					
					4.5	3.94		3.8			3.94		3.8
					5.5	4.94		4.8			4.94		4.8
I <sub>OH</sub> = -75mA <sup>1</sup>	5.5			3.85				3.85					
V <sub>OL</sub>	Low-level output voltage	V <sub>I</sub> = V <sub>IL</sub> or V <sub>IH</sub>	I <sub>OL</sub> = 50μA	3.0		0.1		0.1				V	
				4.5		0.1		0.1		0.1	0.1		
				5.5		0.1		0.1		0.1	0.1		
				I <sub>OL</sub> = 12mA	3.0		3.6		0.44				
					4.5		3.6		0.44		3.6		0.44
					5.5		3.6		0.44		3.6		0.44
I <sub>OL</sub> = 75mA <sup>1</sup>	5.5				1.65			1.65					
I <sub>I</sub>	Input leakage current	V <sub>I</sub> = V <sub>CC</sub> or GND	5.5		±0.1		±0.1		±0.1	±0.1	μA		
I <sub>CC</sub>	Quiescent supply current	V <sub>I</sub> = V <sub>CC</sub> or GND, I <sub>O</sub> = 0mA	5.5		4.0		4.0		4.0	4.0	μA		
ΔI <sub>CC</sub>	Supply current, TTL inputs High <sup>2</sup>	One input at 3.4V, other inputs at V <sub>CC</sub> or GND	5.5						0.9	1.0	mA		

## NOTES:

- Not more than one output should be tested at a time, and the duration of the test should not exceed 10ms.
- This is the increase in supply current for each input that is at one of the specified TTL voltage levels rather than 0V or V<sub>CC</sub>.

## Dual 4-input NAND Schmitt-trigger

## 74AC/ACT11013

### AC ELECTRICAL CHARACTERISTICS AT 3.3V ±0.3V

SYMBOL	PARAMETER	WAVEFORM	74AC11013					UNIT
			T <sub>amb</sub> = +25°C			T <sub>amb</sub> = -40°C to +85°C		
			Min	Typ	Max	Min	Max	
t <sub>PLH</sub> t <sub>PHL</sub>	Propagation delay nA, nB, nC, nD to n $\bar{Y}$	1	2.5 2.3	6.4 6.5	8.7 8.7	2.5 2.3	9.7 9.9	ns

### AC ELECTRICAL CHARACTERISTICS AT 5.0V ±0.5V

SYMBOL	PARAMETER	WAVEFORM	74AC11013					UNIT
			T <sub>amb</sub> = +25°C			T <sub>amb</sub> = -40°C to +85°C		
			Min	Typ	Max	Min	Max	
t <sub>PLH</sub> t <sub>PHL</sub>	Propagation delay nA, nB, nC, nD to n $\bar{Y}$	1	2.0 2.0	4.2 4.4	6.4 6.9	2.0 2.0	7.1 7.8	ns

### AC ELECTRICAL CHARACTERISTICS AT 5.0V ±0.5V

SYMBOL	PARAMETER	WAVEFORM	74ACT11013					UNIT
			T <sub>amb</sub> = +25°C			T <sub>amb</sub> = -40°C to +85°C		
			Min	Typ	Max	Min	Max	
t <sub>PLH</sub> t <sub>PHL</sub>	Propagation delay nA, nB, nC, nD to n $\bar{Y}$	1	1.5 1.5			1.5 1.5		ns

### AC WAVEFORMS

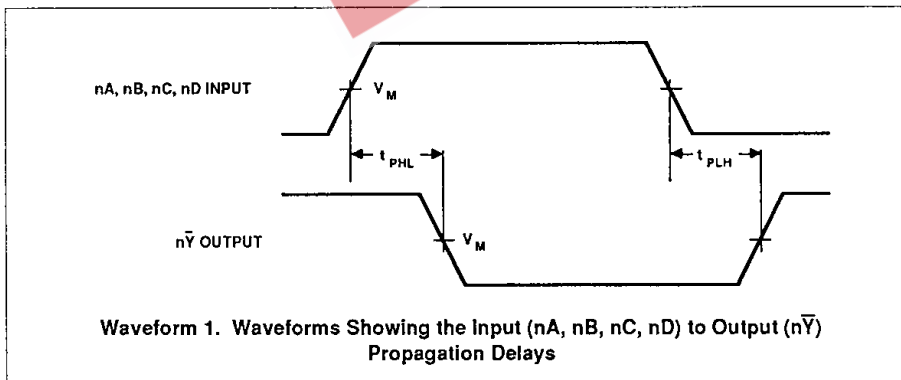

### WAVEFORM CONDITIONS

	INPUTS	OUTPUTS
AC	V <sub>IN</sub> = GND to V <sub>CC</sub> , V <sub>M</sub> = 50% V <sub>CC</sub>	V <sub>OUT</sub> = V <sub>OL</sub> to V <sub>OH</sub>
ACT	V <sub>IN</sub> = GND to 3.0V, V <sub>M</sub> = 1.5V	V <sub>M</sub> = 50% V <sub>CC</sub>

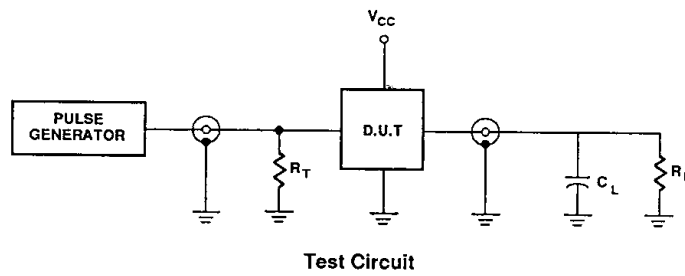
**Dual 4-input NAND Schmitt-trigger****74AC/ACT11013****TEST CIRCUIT**

Test Circuit

**DEFINITIONS**

$C_L$  = Load capacitance, 50pF; includes jig and probe capacitance

$R_L$  = Load resistor, 500 $\Omega$

$R_T$  = Termination resistance should be equal to  $Z_{OUT}$  of pulse generators

Input pulses: PRR  $\leq$  10MHz

$t_r = t_f = 3$ ns