

## ADC0833 8-Bit Serial I/O A/D Converter with 4-Channel Multiplexer

### General Description

The ADC0833 series is an 8-bit successive approximation A/D converter with a serial I/O and configurable input multiplexer with 4 channels. The serial I/O is configured to comply with the NSC MICROWIRE™ serial data exchange standard for easy interface to the COPST™ family of processors, as well as with standard shift registers or  $\mu$ Ps.

The 4-channel multiplexer is software configured for single-ended or differential inputs when channel assigned by a 4-bit serial word.

The differential analog voltage input allows increasing the common-mode rejection and offsetting the analog zero input voltage value. In addition, the voltage reference input can be adjusted to allow encoding any smaller analog voltage span to the full 8 bits of resolution.

### Key Specifications

■ Resolution	8 Bits
■ Total Unadjusted Error	$\pm 1/2$ LSB and $\pm 1$ LSB
■ Single Supply	5 V <sub>DC</sub>
■ Low Power	23 mW
■ Conversion Time	32 $\mu$ s

### Features

- NSC MICROWIRE compatible—direct interface to COPST family processors
- Easy interface to all microprocessors, or operates “stand alone”
- Works with 2.5V (LM336) voltage reference
- No full-scale or zero adjust required
- Differential analog voltage inputs
- 4-channel analog multiplexer
- Shunt regulator allows operation with high voltage supplies
- 0V to 5V input range with single 5V power supply
- Remote operation with serial digital data link
- TTL/MOS input/output compatible
- 0.3” standard width 14-pin DIP package

### Connection and Functional Diagrams

Dual-In-Line Package (J and N)

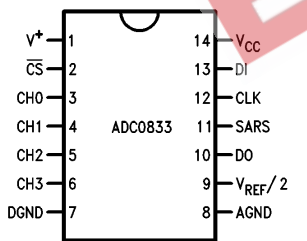

Top View

Order Number ADC0833CCJ,  
ADC0833BCN or ADC0833CCN  
See NS Package Number  
J14A or N14A

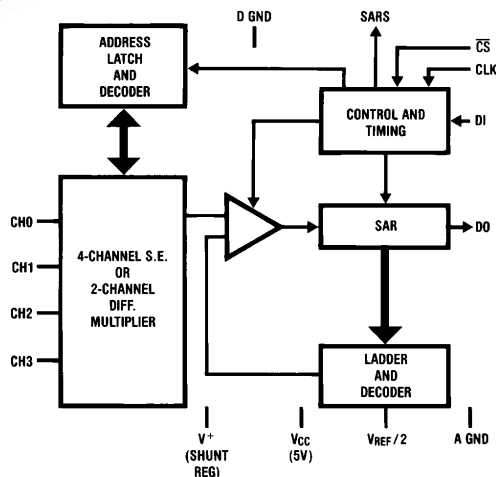

TL/H/5607-1

COPST™ and MICROWIRE™ are trademarks of National Semiconductor Corporation.  
TRI-STATE® is a registered trademark of National Semiconductor Corporation.

## Absolute Maximum Ratings (Notes 1 & 2)

If Military/Aerospace specified devices are required, please contact the National Semiconductor Sales Office/Distributors for availability and specifications.

Current into V <sup>+</sup> (Note 3)	15 mA
Supply Voltage, V <sub>CC</sub> (Note 3)	6.5V
Voltage	
Logic Inputs	−0.3V to V <sub>CC</sub> + 0.3V
Analog Inputs	−0.3V to V <sub>CC</sub> + 0.3V
Input Current per Pin (Note 4)	±5 mA
Package Input Current (Note 4)	±20 mA
Storage Temperature	−65°C to + 150°C

Package Dissipation at T <sub>A</sub> = 25°C (Board Mount)	0.8W
Lead Temperature (Soldering, 10 sec.)	
Dual-In-Line Package (Plastic)	260°C
Dual-In-Line Package (Ceramic)	300°C
ESD Susceptibility (Note 5)	2000V

## Operating Conditions (Notes 1 & 2)

Supply Voltage, V <sub>CC</sub>	4.5 V <sub>DC</sub> to 6.3 V <sub>DC</sub>
Temperature Range	T <sub>MIN</sub> ≤ T <sub>A</sub> ≤ T <sub>MAX</sub>
ADC0833CCJ	−40°C ≤ T <sub>A</sub> ≤ 85°C
ADC0833BCN, ADC0833CCN	0°C ≤ T <sub>A</sub> ≤ 70°C

**Electrical Characteristics** The following specifications apply for V<sub>CC</sub> = V<sup>+</sup> = 5V, f<sub>CLK</sub> = 250 kHz and V<sub>REF/2</sub> ≤ (V<sub>CC</sub> + 0.1V) unless otherwise specified. **Boldface limits apply from T<sub>MIN</sub> to T<sub>MAX</sub>**; all other limits T<sub>A</sub> = T<sub>J</sub> = 25°C.

Parameter	Conditions	Typ (Note 6)	Tested Limit (Note 7)	Design Limit (Note 8)	Units
<b>CONVERTER AND MULTIPLEXER CHARACTERISTICS</b>					
Total Unadjusted Error ADC0833BCN ADC0833CCN ADC0833CCJ	V <sub>REF/2</sub> Forced to 2.500 V <sub>DC</sub>		± 1/2 ± 1 ± 1	± 1/2 ± 1	LSB LSB LSB
Minimum Total Ladder Resistance (Note 9) ADC0833CCJ ADC0833BCN/CCN		7.0 7.0	<b>2.6</b> 2.6	<b>2.6</b>	kΩ kΩ
Maximum Total Ladder Resistance (Note 9) ADC0833CCJ ADC0833BCN/CCN		7.0 7.0	<b>11.8</b> 10.8	<b>11.8</b>	kΩ kΩ
Minimum Common-Mode Input Range (Note 10) ADC0833CCJ ADC0833BCN/CCN	All MUX Inputs and COM Input		<b>GND − 0.05</b> GND − 0.05	<b>GND − 0.05</b>	V V
Maximum Common-Mode Input Range (Note 10) ADC0833CCJ ADC0833BCN/CCN	All MUX Inputs and COM Input		<b>V<sub>CC</sub> + 0.05</b> V <sub>CC</sub> + 0.05	<b>V<sub>CC</sub> + 0.05</b>	V V
DC Common-Mode Error ADC0833CCJ ADC0833BCN/CCN		± 1/16 ± 1/16	± 1/4 ± 1/4	± 1/4	LSB LSB
Change In Zero Error From V <sub>CC</sub> = 5V To Internal Zener Operation (Note 3) ADC0833CCJ ADC0833BCN/CCN	15mA Into V <sup>+</sup> V <sub>CC</sub> = N.C. V <sub>REF/2</sub> = 2.500V		<b>1</b> 1	<b>1</b>	LSB LSB

**Electrical Characteristics** The following specifications apply for  $V_{CC} = V^+ = 5V$ ,  $f_{CLK} = 250\text{ kHz}$  and  $V_{REF}/2 \leq (V_{CC} + 0.1V)$  unless otherwise specified. **Boldface limits apply from  $t_{MIN}$  to  $t_{MAX}$** ; all other limits  $T_A = T_j = 25^\circ C$ . (Continued)

Parameter	Conditions	Typ (Note 6)	Tested Limit (Note 7)	Design Limit (Note 8)	Units
<b>CONVERTER AND MULTIPLEXER CHARACTERISTICS</b> (Continued)					
$V_Z$ , Minimum Internal Diode Breakdown (At $V^+$ ) (Note 3) ADC0833CCJ ADC0833BCN/CCN	15mA Into $V^+$		<b>6.3</b> 6.3	<b>6.3</b>	V V
$V_Z$ , Maximum Internal Diode Breakdown (At $V^+$ ) (Note 3) ADC0833CCJ ADC0833BCN/CCN	15mA Into $V^+$		<b>8.5</b> 8.5	<b>8.5</b>	V V
Power Supply Sensitivity ADC0833CCJ ADC0833BCN/CCN	$V_{CC} = 5V \pm 5\%$	$\pm 1/16$ $\pm 1/16$	$\pm 1/4$ $\pm 1/4$	$\pm 1/4$	LSB LSB
$I_{OFF}$ , Off Channel Leakage Current (Note 11) ADC0833CCJ ADC0833BCN/CCN	On Channel = 5V, Off Channel = 0V		-1 -200 -200	-1	$\mu A$ nA $\mu A$ nA
	On Channel = 0V, Off Channel = 5V		1 200 200	1	$\mu A$ nA $\mu A$ nA
$I_{ON}$ , On Channel Leakage Current (Note 11) ADC0833CCJ ADC0833BCN/CCN	On Channel = 5V, Off Channel = 0V		1 200 200	1	$\mu A$ nA $\mu A$ nA
	On Channel = 0V, Off Channel = 5V		-1 -200 -200	-1	$\mu A$ nA $\mu A$ nA
<b>DIGITAL AND DC CHARACTERISTICS</b>					
$V_{IN(1)}$ , Logical "1" Input Voltage ADC0833CCJ ADC0833BCN/CCN	$V_{CC} = 5.25V$		<b>2.0</b> 2.0	<b>2.0</b>	V V
$V_{IN(0)}$ , Logical "0" Input Voltage ADC0833CCJ ADC0833BCN/CCN	$V_{CC} = 4.75V$		<b>0.8</b> 0.8	<b>0.8</b>	V V
$I_{IN(1)}$ , Logical "1" Input Current ADC0833CCJ ADC0833BCN/CCN	$V_{IN} = V_{CC}$	0.005 0.005	1 1	1	$\mu A$ $\mu A$

**Electrical Characteristics** The following specifications apply for  $V_{CC} = V^+ = 5V$ ,  $f_{CLK} = 250\text{ kHz}$  and  $V_{REF}/2 \leq (V_{CC} + 0.1V)$  unless otherwise specified. **Boldface limits apply from  $t_{MIN}$  to  $t_{MAX}$** ; all other limits  $T_A = T_j = 25^\circ\text{C}$ . (Continued)

Parameter	Conditions	Typ (Note 6)	Tested Limit (Note 7)	Design Limit (Note 8)	Units
<b>DIGITAL AND DC CHARACTERISTICS</b> (Continued)					
$I_{IN(0)}$ , Logical "0" Input Current ADC0833CCJ ADC0833BCN/CCN	$V_{IN} = 0V$	-0.005 -0.005	-1 -1	-1	$\mu\text{A}$ $\mu\text{A}$
$V_{OUT(1)}$ , Logical "1" Output Voltage ADC0833CCJ ADC0833BCN/CCN ADC0833CCJ ADC0833BCN/CCN	$V_{CC} = 4.75V$ $I_{OUT} = -360\mu\text{A}$ $I_{OUT} = -10\mu\text{A}$		2.4 2.4 4.5 4.5	2.4 2.4 4.5 4.5	V V V V
$V_{OUT(0)}$ , Logical "0" Output Voltage ADC0833CCJ ADC0833BCN/CCN	$I_{OUT} = 1.6\text{mA}$ , $V_{CC} = 4.75V$		0.4 0.4	0.4 0.4	V V
$I_{OUT}$ , TRI-STATE Output Current (DO, SARS) ADC0833CCJ ADC0833BCN/CCN ADC0833CCJ ADC0833BCN/CCN	$V_{OUT} = 0.4V$ $V_{OUT} = 5V$	-0.1 -0.1 0.1 0.1	-3 -3 3 3	-3 -3 3 3	$\mu\text{A}$ $\mu\text{A}$ $\mu\text{A}$ $\mu\text{A}$
$I_{SOURCE}$ ADC0833CCJ ADC0833BCN/CCN	$V_{OUT}$ Short to GND	-14 -14	-6.5 -7.5	-6.5	mA mA
$I_{SINK}$ ADC0833CCJ ADC0833BCN/CCN	$V_{OUT}$ Short to $V_{CC}$	16 16	8.0 9.0	8.0	mA mA
$I_{CC}$ , Supply Current (Note 3) ADC0833CCJ ADC0833BCN/CCN	$V_{REF}/2$ Open Circuit	0.9 0.9	4.5 4.5	4.5	mA mA

**AC Electrical Characteristics** The following specifications apply for  $V_{CC} = V^+ = 5V$  and  $t_r = t_f = 20\text{ ns}$  unless otherwise specified. These limits apply for  $T_A = T_j = 25^\circ\text{C}$ .

Parameter	Conditions	Typ (Note 6)	Tested Limit (Note 7)	Design Limit (Note 8)	Units
$f_{CLK}$ , Clock Frequency	Min Max		10	400	kHz kHz
$T_C$ , Conversion Time	Not including MUX Addressing Time		8		$1/f_{CLK}$
Clock Duty Cycle (Note 12)	Min Max			40 60	% %
$t_{SET-UP, \overline{CS}}$ Falling Edge or Data Input Valid to CLK Rising Edge				250	ns
$t_{HOLD}$ , Data Input Valid after CLK Rising Edge				90	ns
$t_{pd1}$ , $t_{pd0}$ —CLK Falling Edge to Output Data Valid (Note 13)	$C_L = 100\text{ pF}$ Data MSB First Data LSB First	650 250		1500 600	ns ns
$t_{1H}$ , $t_{OH}$ —Rising Edge of $\overline{CS}$ to Data Output and SARS Hi-Z	$C_L = 10\text{ pF}$ , $R_L = 10k$ $C_L = 100\text{ pF}$ , $R_L = 2k$ (see TRI-STATE Test Circuits)	125	500	250	ns ns
$C_{IN}$ , Capacitance of Logic Input		5			pF
$C_{OUT}$ , Capacitance of Logic Outputs		5			pF

**Note 1:** Absolute Maximum Ratings indicate limits beyond which damage to the device may occur. DC and AC electrical specifications do not apply when operating the device beyond its specified operating conditions.

**Note 2:** All voltages are measured with respect to the ground pins.

**Note 3:** Internal zener diodes (approx. 7V) are connected from  $V^+$  to GND and  $V_{CC}$  to GND. The zener at  $V^+$  can operate as a shunt regulator and is connected to  $V_{CC}$  via a conventional diode. Since the zener voltage equals the A/D's breakdown voltage, the diode insures that  $V_{CC}$  will be below breakdown when the device is powered from  $V^+$ . Functionality is therefore guaranteed for  $V^+$  operation even though the resultant voltage at  $V_{CC}$  may exceed the specified Absolute Max. of 6.5V. It is recommended that a resistor be used to limit the max. current into  $V^+$ .

**Note 4:** When the input voltage ( $V_{IN}$ ) at any pin exceeds the power supply rails ( $V_{IN} < V^-$  or  $V_{IN} > V^+$ ) the absolute value of current at that pin should be limited to 5 mA or less. The 20 mA package input current limits the number of pins that can exceed the power supply boundaries with a 5 mA current limit to four.

**Note 5:** Human body model, 100 pF discharged through a 1.5 k $\Omega$  resistor.

**Note 6:** Typicals are at 25°C and represent most likely parametric norm.

**Note 7:** Tested limits are guaranteed to National's AOQL (Average Outgoing Quality Level).

**Note 8:** Design limits are guaranteed but not 100% tested. These limits are not used to calculate outgoing quality levels.

**Note 9:** See Applications, section 3.0.

**Note 10:** For  $V_{IN}(-) \geq V_{IN}(+)$  the digital output code will be 0000 0000. Two on-chip diodes are tied to each analog input (see Block Diagram) which will forward conduct for analog input voltages one diode drop below ground or one diode drop greater than the  $V_{CC}$  supply. Be careful, during testing at low  $V_{CC}$  levels (4.5V), as high level analog inputs (5V) can cause this input diode to conduct—especially at elevated temperatures, and cause errors for analog inputs near full-scale. The spec allows 50 mV forward bias of either diode. This means that as long as the analog  $V_{IN}$  or  $V_{REF}$  does not exceed the supply voltage by more than 50 mV, the output code will be correct. To achieve an absolute 0  $V_{DC}$  to 5  $V_{DC}$  input voltage range will therefore require a minimum supply voltage of 4.950  $V_{DC}$  over temperature variations, initial tolerance and loading.

**Note 11:** Leakage current is measured with the clock not switching.

**Note 12:** A 40% to 60% clock duty cycle range insures proper operation at all clock frequencies. In the case that an available clock has a duty cycle outside of these limits, the minimum time the clock is high or the minimum time the clock is low must be at least 1  $\mu\text{s}$ . The maximum time the clock can be high is 60  $\mu\text{s}$ . The clocked can be stopped when low so long as the analog input voltage remains stable.

**Note 13:** Since data, MSB first, is the output of the comparator used in the successive approximation loop, an additional delay is built in (see Block Diagram) to allow for comparator response time.

## Timing Diagrams

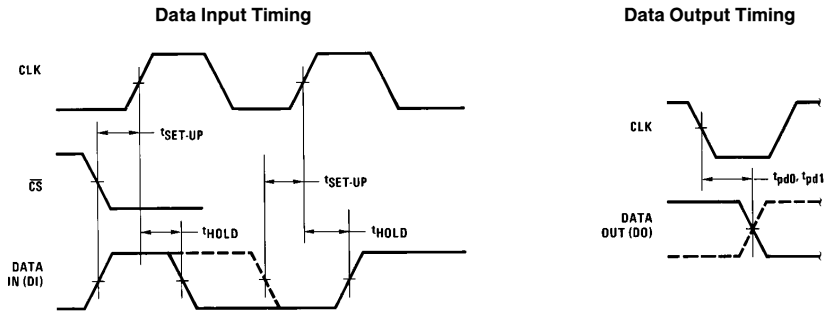

## TRI-STATE Test Circuits and Waveforms

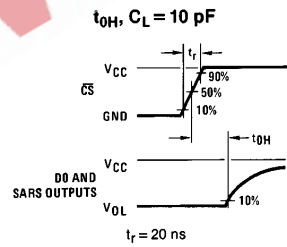
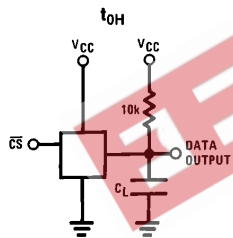
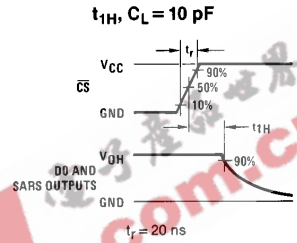
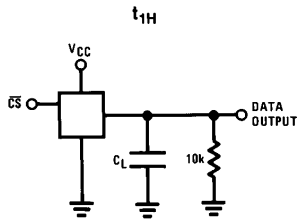

## Leakage Current Test Circuit

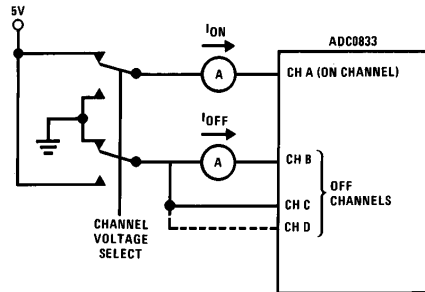

TL/H/5607-2

## Typical Performance Characteristics

**Effect of Unadjusted Offset Error vs  $V_{REF}/2$  Voltage**

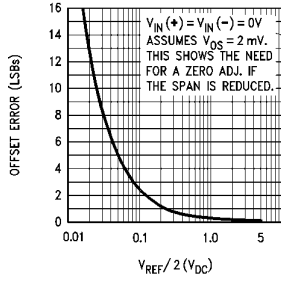

**Linearity Error vs  $V_{REF}$  Voltage**

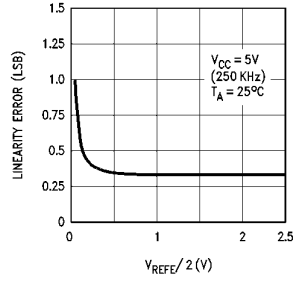

**Linearity Error vs Temperature**

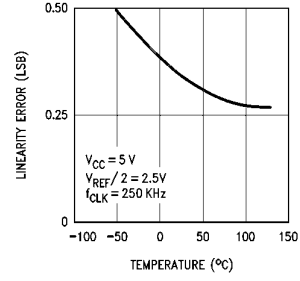

**Linearity Error vs  $f_{CLK}$**

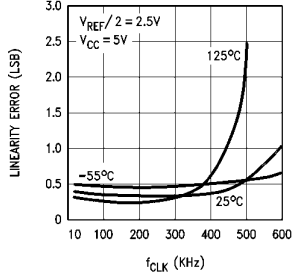

**Power Supply Current vs Temperature**

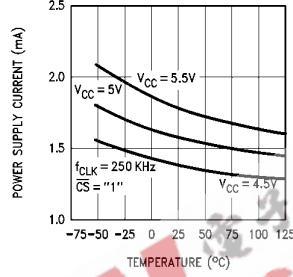

**Output Current vs Temperature**

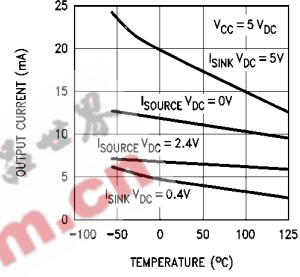

**Power Supply Current vs  $f_{CLK}$**

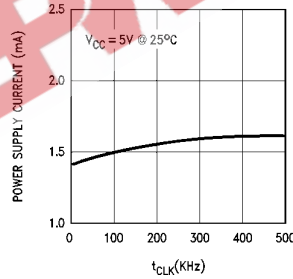

TL/H/5607-3

# ADC0833 Functional Block Diagram

TL/H/6607-4

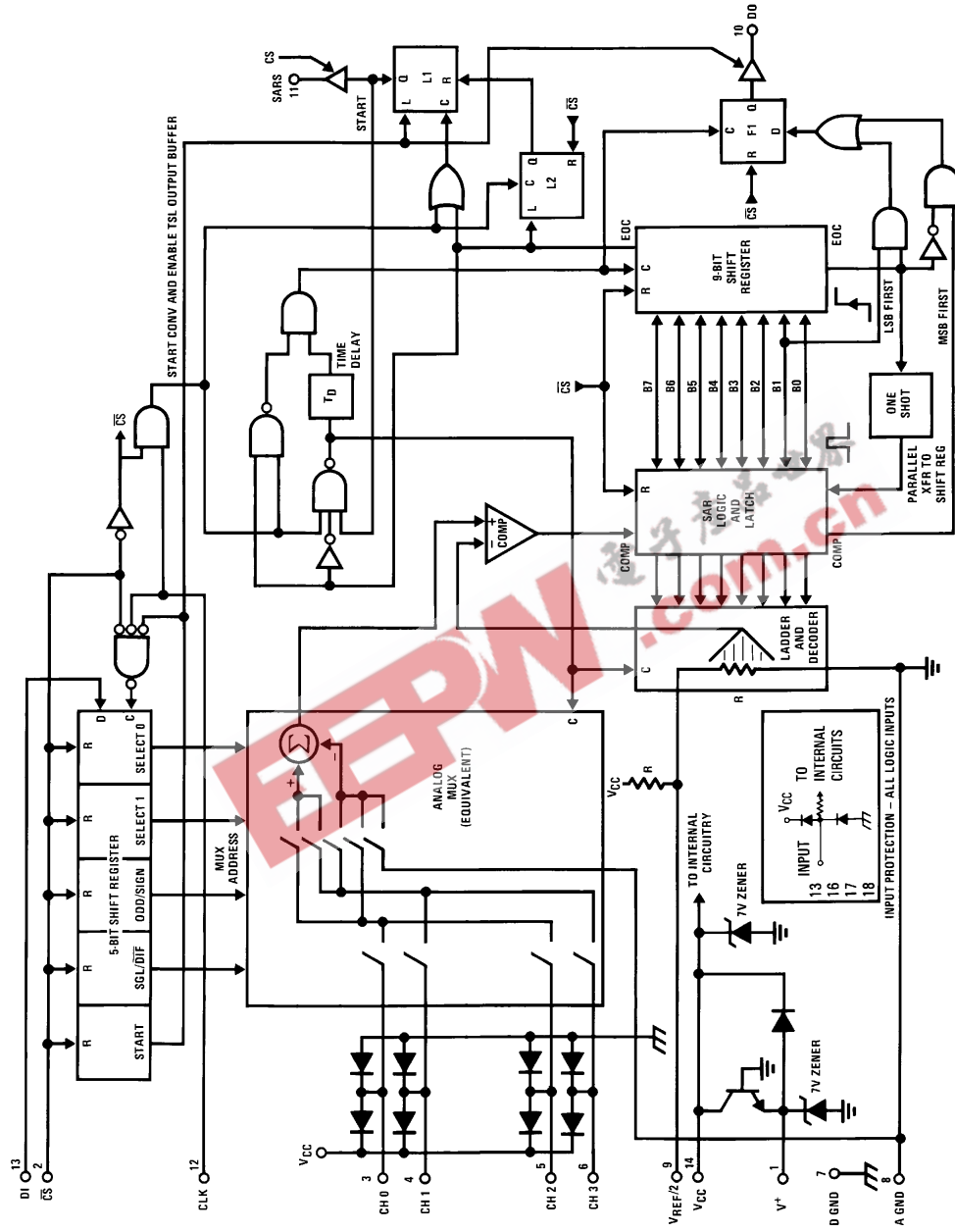



## Timing Diagram

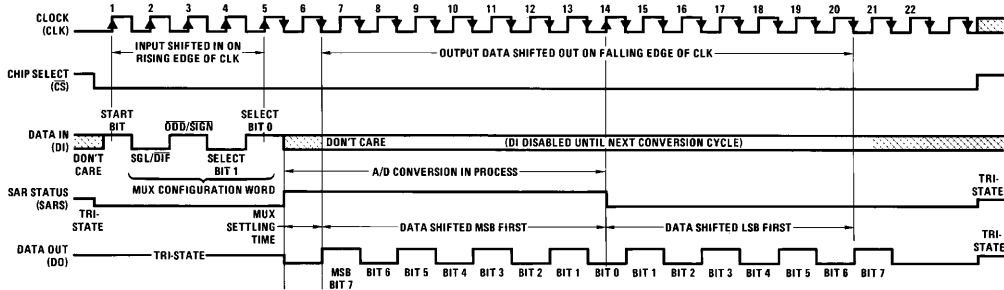

TL/H/5607-5

## Functional Description

### 1.0 MULTIPLEXER ADDRESSING

The design of the ADC0833 utilizes a sample-data comparator structure which provides for a differential analog input to be converted by a successive approximation routine.

The actual voltage converted is always the difference between an assigned "+" input terminal and a "-" input terminal. The polarity of each input terminal of the pair being converted indicates which line the converter expects to be the most positive. If the assigned "+" input is less than the "-" input the converter responds with an all zeros output code.

A unique input multiplexing scheme has been utilized to provide multiple analog channels with software-configurable single-ended (ground referred) or differential inputs. The analog signal conditioning required in transducer-based data

acquisition systems is significantly simplified with this type of input flexibility. One converter package can now handle ground referenced inputs and true differential inputs.

A particular input configuration is assigned during the MUX addressing sequence, prior to the start of a conversion. The MUX address selects which of the analog inputs are to be enabled and whether this input is single-ended or differential. In the differential case, it also assigns the polarity of the channels. Differential inputs are restricted to adjacent channel pairs. For example channel 0 and channel 1 may be selected as a differential pair. Channel 0 or 1 cannot act differentially with any other channel. In addition to selecting differential mode the sign may also be selected. Channel 0 may be selected as the positive input and channel 1 as the negative input or vice versa. This programmability is best illustrated by the MUX addressing codes shown in the following table. The MUX address is shifted into the converter through the DI line.

TABLE I. MUX Addressing

#### Single-Ended MUX Mode

Address		Channel #					
SGL/ DIF	ODD/ SIGN	SELECT		0	1	2	3
		1	0				
1	0	0	1	+			
1	0	1	1			+	
1	1	0	1		+		
1	1	1	1				+

COM is internally ties to a GND

#### Differential MUX Mode

Address		Channel #					
SGL/ DIF	ODD/ SIGN	SELECT		0	1	2	3
		1	0				
0	0	0	1	+	-		
0	0	1	1			+	-
0	1	0	1	-	+		
0	1	1	1			-	+

## Functional Description (Continued)

Since the input configuration is under software control, it can be modified, as required, at each conversion. A channel can be treated as a single-ended, ground referenced input for one conversion; then it can be reconfigured as part of a differential channel for another conversion. *Figure 1* illustrates the input flexibility which can be achieved.

The analog input voltages for each channel can range from 50 mV below ground to 50mV above  $V_{CC}$ (typically 5V) without degrading conversion accuracy.

### 2.0 THE DIGITAL INTERFACE

A most important characteristic of these converters is their serial data link with the controlling processor. Using a serial communication format offers two very significant system improvements; it allows more function to be included in the converter package with no increase in package size and it can eliminate the transmission of low level analog signals by locating the converter right at the analog sensor; transmit-

ting highly noise immune digital data back to the host processor.

To understand the operation of these converters it is best to refer to the Timing Diagram and Functional Block Diagram and to follow a complete conversion sequence.

1. A conversion is initiated by first pulling the  $\overline{CS}$  (chip select) line low. This line must be held low for the entire conversion. The converter is now waiting for a start bit and its MUX assignment word.

2. A clock is then generated by the processor (if not provided continuously) and output to the A/D clock input.

3. On each rising edge of the clock the status of the data in (DI) line is clocked into the MUX address shift register. The start bit is the first logic "1" that appears on this line (all leading zeros are ignored). Following the start bit the converter expects the next 4 bits to be the MUX assignment word.

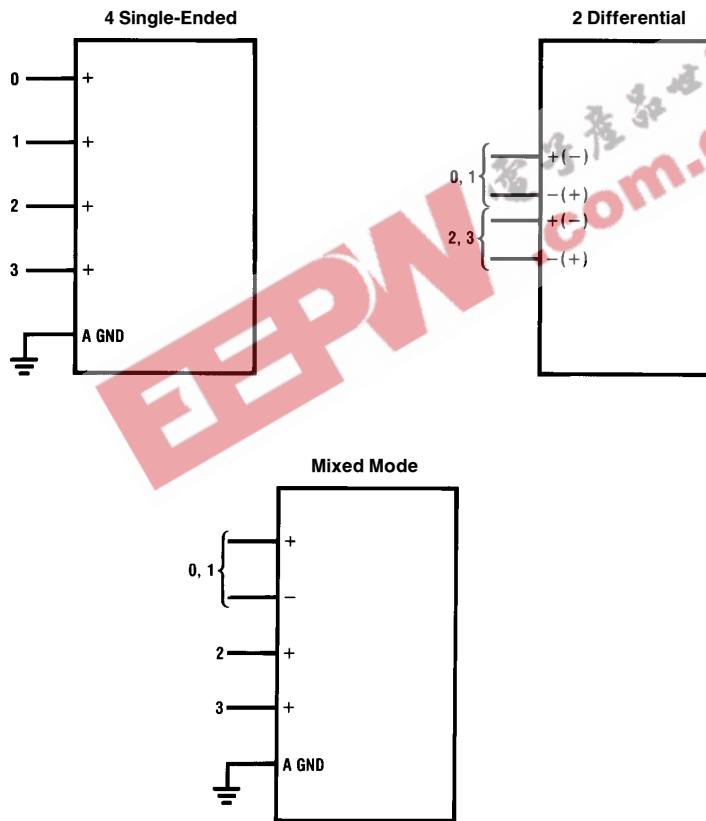

TL/H/5607-6

FIGURE 1. Analog Input Multiplexer Options for the ADC0833

## Functional Description (Continued)

4. When the start bit has been shifted into the start location of the MUX register, the input channel has been assigned and a conversion is about to begin. An interval of  $1/2$  clock period (where nothing happens) is automatically inserted to allow the selected MUX channel to settle. The SAR status line goes high at this time to signal that a conversion is now in progress and the DI line is disabled (it no longer accepts data).

5. The data out (DO) line now comes out of TRI-STATE and provides a leading zero for this one clock period of MUX settling time.

6. When the conversion begins, the output of the SAR comparator, which indicates whether the analog input is greater than (high) or less than (low) each successive voltage from the internal resistor ladder, appears at the DO line on each falling edge of the clock. This data is the result of the conversion being shifted out (with the MSB coming first) and can be read by the processor immediately.

7. After 8 clock periods the conversion is completed. The SAR status line returns low to indicate this  $1/2$  clock cycle later.

8. If the programmer prefers, the data can be read in an LSB first format. All 8 bits of the result are stored in an output shift register. The conversion result, LSB first, is automatically shifted out the DO line, after the MSB first data stream. The DO line then goes low and stays low until  $\overline{CS}$  is returned high.

9. All internal registers are cleared when the  $\overline{CS}$  line is high. If another conversion is desired,  $\overline{CS}$  must make a high to low transition followed by address information.

The DI and DO lines can be tied together and controlled through a bidirectional processor I/O bit with one wire. This is possible because the DI input is only "looked-at" during the MUX addressing interval while the DO line is still in a high impedance state.

### 3.0 REFERENCE CONSIDERATIONS

The ADC0833 is intended primarily for use in circuits requiring absolute accuracy. In this type of system, the analog

inputs vary between very specific voltage limits and the reference voltage for the A/D converter must remain stable with time and temperature. For ratiometric applications, an ADC0834 is a pin-for-pin compatible alternative since it has a  $V_{REF}$  input (note the ADC0834 needs one less bit of mux addressing information).

The voltage applied to the  $V_{REF}/2$  pin defines the voltage span of the analog input [the difference between  $V_{IN}(+)$  and  $V_{IN}(-)$ ] over which the 256 possible output codes apply. A full-scale conversion (an all 1s output code) will result when the voltage difference between a selected "+" input and "-" input is approximately *twice* the voltage at the  $V_{REF}/2$  pin. This internal gain of 2 from the applied reference to the full-scale input voltage allows biasing a low voltage reference diode from the  $5V_{DC}$  converter supply. To accommodate a 5V input span, only a 2.5V reference is required. The LM385 and LM336 reference diodes are good low current devices to use with these converters. The output code changes in accordance with the following equation:

$$\text{Output Code} = 256 \left( \frac{V_{IN}(+) - V_{IN}(-)}{2(V_{REF}/2)} \right)$$

where the output code is the decimal equivalent of the 8-bit binary output (ranging from 0 to 255) and the term  $V_{REF}/2$  is the voltage from pin 9 to ground.

The  $V_{REF}/2$  pin is the center point of a two resistor divider (each resistor is  $3.5 \text{ k}\Omega$ ) connected from  $V_{CC}$  to ground. Total ladder input resistance is the sum of these two equal resistors. As shown in Figure 2, a reference diode with a voltage less than  $V_{CC}/2$  can be connected without requiring an external biasing resistor if its current requirements meet the indicated level.

The minimum value of  $V_{REF}/2$  can be quite small (see Typical Performance Characteristics) to allow direct conversions of transducer outputs providing less than a 5V output span. Particular care must be taken with regard to noise pickup, circuit layout and system error voltage sources when operating with a reduced span due to the increased sensitivity of the converter (1 LSB equals  $V_{REF}/256$ ).

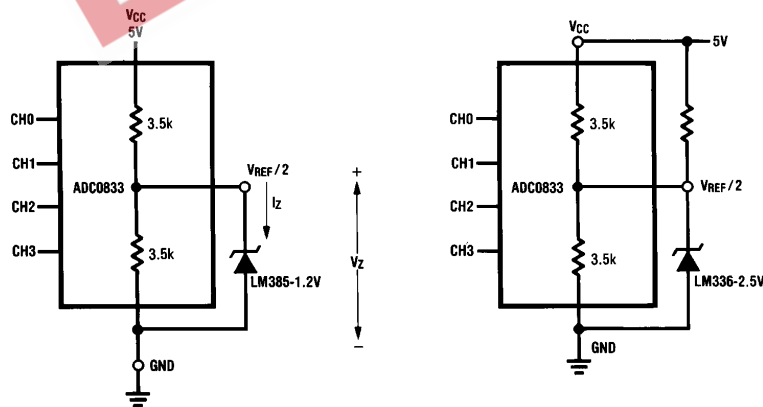

$V_{FULL-SCALE} \approx 2.4V$

$V_{FULL-SCALE} \approx 5.0V$

Note: No external biasing resistor needed if  $V_Z < \frac{V_{CC}}{2}$  and  $I_Z \text{ min} < \frac{V_{CC}/2 - V_Z}{1.75 \text{ k}\Omega}$

FIGURE 2. Reference Biasing Examples

TL/H/5607-7

## Functional Description (Continued)

### 4.0 THE ANALOG INPUTS

The most important feature of these converters is that they can be located right at the analog signal source and through just a few wires can communicate with a controlling processor with a highly noise immune serial bit stream. This in itself greatly minimizes circuitry to maintain analog signal accuracy which otherwise is most susceptible to noise pickup. However, a few words are in order with regard to the analog inputs should the inputs be noisy to begin with or possibly riding on a large common-mode voltage.

The differential input of these converters actually reduces the effects of common-mode input noise, a signal common to both selected “+” and “-” inputs for a conversion (60 Hz is most typical). The time interval between sampling the “+” input and then the “-” input is  $\frac{1}{2}$  of a clock period. The change in the common-mode voltage during this short time interval can cause conversion errors. For a sinusoidal common-mode signal this error is:

$$V_{\text{error(max)}} = V_{\text{PEAK}}(2\pi f_{\text{CM}}) \left( \frac{0.5}{f_{\text{CLK}}} \right)$$

where  $f_{\text{CM}}$  is the frequency of the common-mode signal,

$V_{\text{PEAK}}$  is its peak voltage value

and  $f_{\text{CLK}}$  is the A/D clock frequency.

For a 60 Hz common-mode signal to generate a  $\frac{1}{4}$  LSB error ( $\approx 5$  mV) with the converter running at 250 kHz, its peak value would have to be 6.63V which would be larger than allowed as it exceeds the maximum analog input limits.

Due to the sampling nature of the analog inputs short spikes of current enter the “+” input and exit the “-” input at the clock edges during the actual conversion. These currents decay rapidly and do not cause errors as the internal comparator is strobed at the end of a clock period. Bypass capacitors at the inputs will average these currents and cause an effective DC current to flow through the output resistance of the analog signal source. Bypass capacitors should not be used if the source resistance is greater than 1 k $\Omega$ .

This source resistance limitation is important with regard to the DC leakage currents of input multiplexer as well. The worst-case leakage current of  $\pm 1$   $\mu$ A over temperature will create a 1 mV input error with a 1 k $\Omega$  source resistance. An op amp RC active low pass filter can provide both impedance buffering and noise filtering should a high impedance signal source be required.

### 5.0 OPTIONAL ADJUSTMENTS

#### 5.1 Zero Error

The zero of the A/D does not require adjustment. If the minimum analog input voltage value,  $V_{\text{IN(MIN)}}$ , is not ground a zero offset can be done. The converter can be made to output 0000 0000 digital code for this minimum input voltage by biasing any  $V_{\text{IN}}(-)$  input at this  $V_{\text{IN(MIN)}}$  value. This utilizes the differential mode operation of the A/D.

The zero error of the A/D converter relates to the location of the first riser of the transfer function and can be measured by grounding the  $V_{\text{IN}}(-)$  input and applying a small magnitude positive voltage to the  $V_{\text{IN}}(+)$  input. Zero error is the difference between the actual DC input voltage which

is necessary to just cause an output digital code transition from 0000 0000 to 0000 0001 and the ideal  $\frac{1}{2}$  LSB value ( $\frac{1}{2}$  LSB = 9.8 mV for  $V_{\text{REF}}/2 = 2.500$  V<sub>DC</sub>).

#### 5.2 Full-Scale

The full-scale adjustment can be made by applying a differential input voltage which is 1  $\frac{1}{2}$  LSB down from the desired analog full-scale voltage range and then adjusting the magnitude of the  $V_{\text{REF}}$  input or  $V_{\text{CC}}$  for a digital output code which is just changing from 1111 1110 to 1111 1111.

#### 5.3 Adjusting for an Arbitrary Analog Input Voltage Range

If the analog zero voltage of the A/D is shifted away from ground (for example, to accommodate an analog input signal which does not go to ground), this new zero reference should be properly adjusted first. A  $V_{\text{IN}}(+)$  voltage which equals this desired zero reference plus  $\frac{1}{2}$  LSB (where the LSB is calculated for the desired analog span, using 1 LSB = analog span/256) is applied to selected “+” input and the zero reference voltage at the corresponding “-” input should then be adjusted to just obtain the 00<sub>HEX</sub> to 01<sub>HEX</sub> code transition.

The full-scale adjustment should be made [with the proper  $V_{\text{IN}}(-)$  voltage applied] by forcing a voltage to the  $V_{\text{IN}}(+)$  input which is given by:

$$V_{\text{IN}}(+)\text{ fs adj} = V_{\text{MAX}} - 1.5 \left[ \frac{(V_{\text{MAX}} - V_{\text{MIN}})}{256} \right]$$

where:

$V_{\text{MAX}}$  = the high end of the analog input range

and

$V_{\text{MIN}}$  = the low end (the offset zero) of the analog range.

(Both are ground referenced.)

The  $V_{\text{REF}}/2$  voltage is then adjusted to provide a code change from FE<sub>HEX</sub> to FF<sub>HEX</sub>. This completes the adjustment procedure.

### 6.0 POWER SUPPLY

A unique feature of the ADC0833 is the inclusion of a 7V zener diode connected from the  $V^+$  terminal to ground which also connects to the  $V_{\text{CC}}$  terminal (which is the actual converter supply) through a silicon diode, as shown in Figure 3.

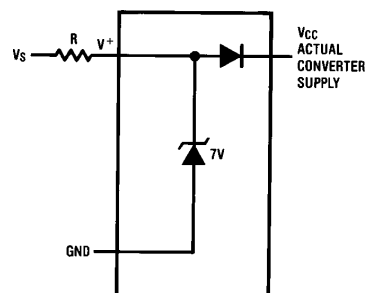

TL/H/5607-8

FIGURE 3. An On-Chip Shunt Regulator Diode

## Functional Description (Continued)

This zener is intended for use as a shunt voltage regulator to eliminate the need for any additional regulating components. This is most desirable if the converter is to be remotely located from the system power source. *Figures 4 and 5* illustrate two useful applications of this on-board zener when an external transistor can be afforded.

An important use of the interconnecting diode between  $V^+$  and  $V_{CC}$  is shown in *Figures 6 and 7*. Here, this diode is used as a rectifier to allow the  $V_{CC}$  supply for the converter

to be derived from the clock. The low current requirements of the A/D ( $\sim 3$  mA) and the relatively high clock frequencies used (typically in the range of 10k-400 kHz) allows using the small value filter capacitor shown to keep the ripple on the  $V_{CC}$  line to well under  $1/4$  of an LSB. The shunt zener regulator can also be used in this mode. This requires a clock voltage swing which is in excess of  $V_Z$ . A current limit for the zener is needed, either built into the clock generator or a resistor can be used from the CLK pin to the  $V^+$  pin.

## Applications

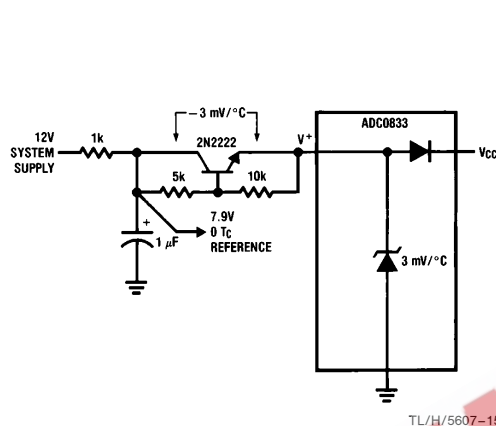

FIGURE 4. Operating with a Temperature Compensated Reference

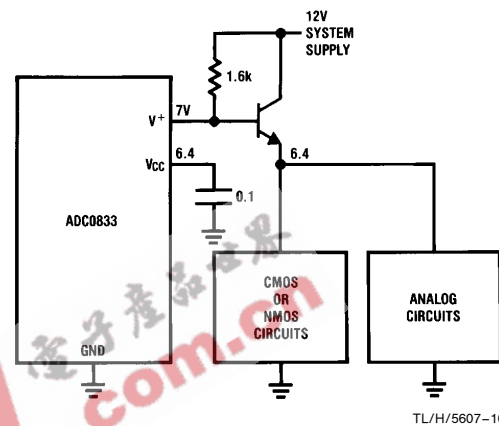

FIGURE 5. Using the A/D as the System Supply Regulator

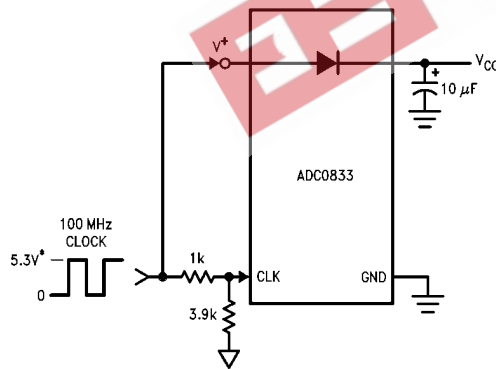

FIGURE 6. Generally  $V_{CC}$  from the Converter Clock  
\*Note  $4.5V \leq V_{CC} \leq 6.3V$

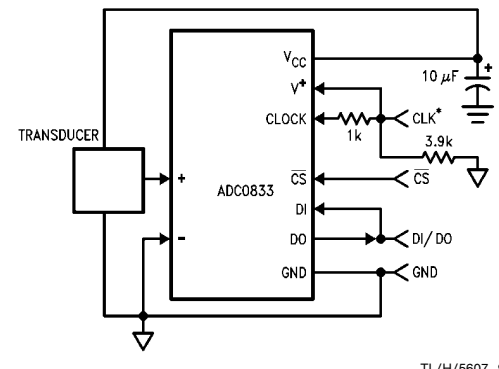
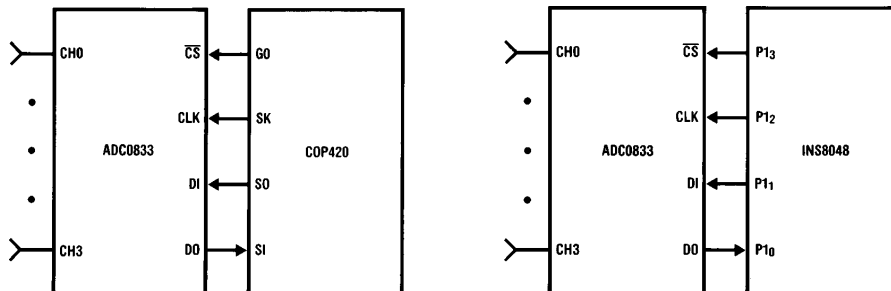

FIGURE 7. Remote Sensing—Clock and Power on 1 Wire

## Applications (Continued)

### Digital Link and Sample Controlling Software for the Serially Oriented COP420 and the Bit Programmable I/O INS8048



TL/H/5607-10

#### COP CODING EXAMPLE

Mnemonic	Instruction
LEI	ENABLES SIO's INPUT AND OUTPUT
SC	C = 1
OGI	G0 = 0 ( $\overline{CS}$ = 0)
CLR A	CLEARs ACCUMULATOR
AISC 1	LOADS ACCUMULATOR WITH 1
XAS	EXCHANGES SIO WITH ACCUMULATOR AND STARTS SK CLOCK
LDD	LOADS MUX ADDRESS FROM RAM INTO ACCUMULATOR
NOP	—
XAS	LOADS MUX ADDRESS FROM ACCUMULATOR TO SIO REGISTER
↑ 8 INSTRUCTIONS ↓	
XAS	READS HIGH ORDER NIBBLE (4 BITS) INTO ACCUMULATOR
XIS	PUTS HIGH ORDER NIBBLE INTO RAM
CLR A	CLEARs ACCUMULATOR
RC	C = 0
XAS	READS LOW ORDER NIBBLE INTO ACCUMULATOR AND STOPS SK
XIS	PUTS LOW ORDER NIBBLE INTO RAM
OGI	G0 = 1 ( $\overline{CS}$ = 1)
LEI	DISABLES SIO's INPUT AND OUTPUT

#### 8048 CODING EXAMPLE

Mnemonic	Instruction
START:	ANL P1, #0F7H ;SELECT A/D ( $\overline{CS}$ = 0)
	MOV B, #5 ;BIT COUNTER ← 5
	MOV A, #ADDR ;A ← MUX ADDRESS
LOOP 1:	RRC A ;CY ← ADDRESS BIT
	JC ONE ;TEST BIT
	;BIT = 0
ZERO:	ANL P1, #0FEH ;DI ← 0
	JMP CONT ;CONTINUE
	;BIT = 1
ONE:	ORL P1, #1 ;DI ← 1
CONT:	CALL PULSE ;PULSE SK 0 → 1 → 0
	DJNZ B, LOOP 1 ;CONTINUE UNTIL DONE
	CALL PULSE ;EXTRA CLOCK FOR SYNC
	MOV B, #8 ;BIT COUNTER ← 8
LOOP 2:	CALL PULSE ;PULSE SK 0 → 1 → 0
	IN A, P1 ;CY ← DO
	RRC A
	RRC A
	MOV A, C ;A ← RESULT
	RLC A ;A(0) ← BIT AND SHIFT
	MOV C, A ;C ← RESULT
	DJNZ B, LOOP 2 ;CONTINUE UNTIL DONE
RETR	;PULSE SUBROUTINE
PULSE:	ORL P1, #04 ;SK ← 1
	NOP ;DELAY
	ANL P1, #0FBH ;SK ← 0
	RET

## Applications (Continued)

### A "Stand-Alone" Hook-Up for ADC0833 Evaluation

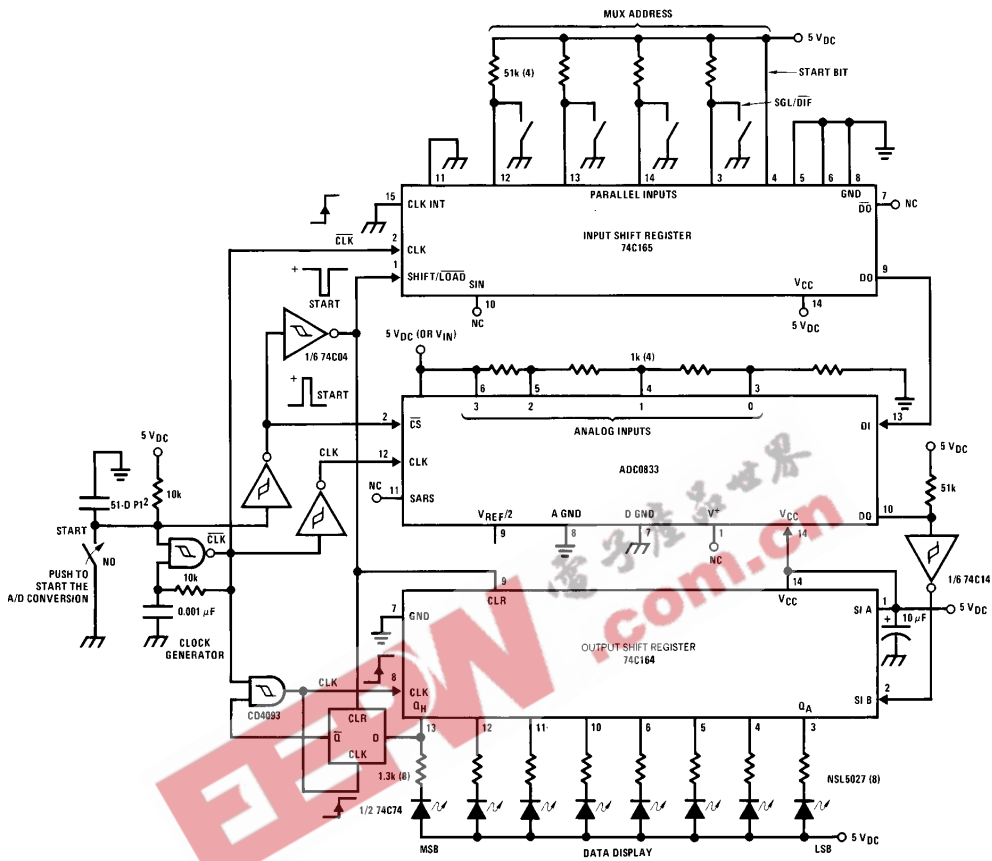

### Low Cost Remote Temperature Sensor

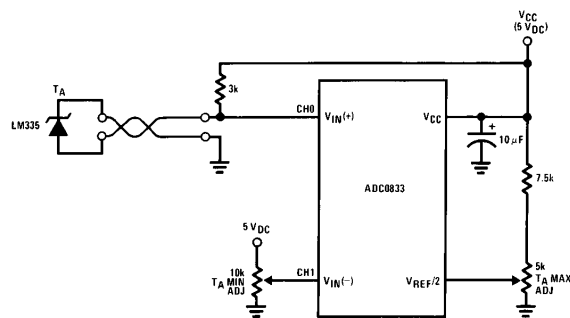

TL/H/5607-11

## Applications (Continued)

### Digitizing a Current Flow

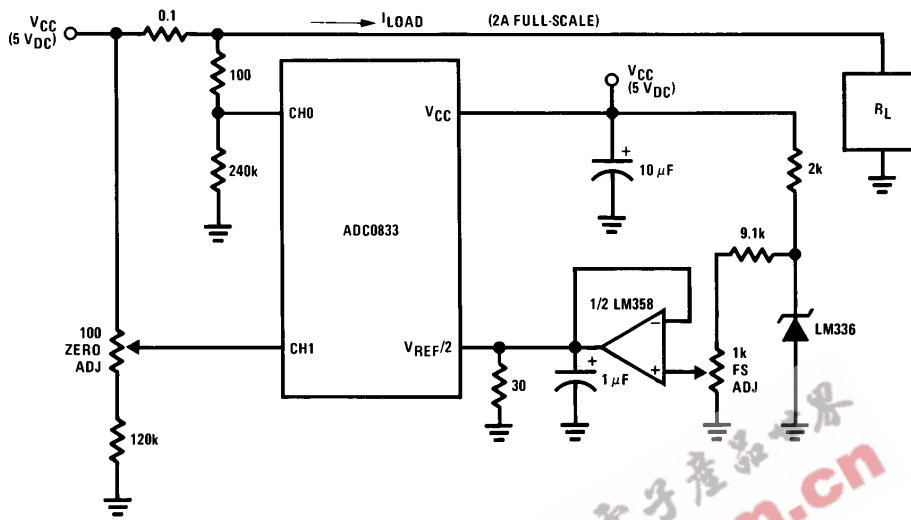

### Operating with Automotive Ratiometric Transducers

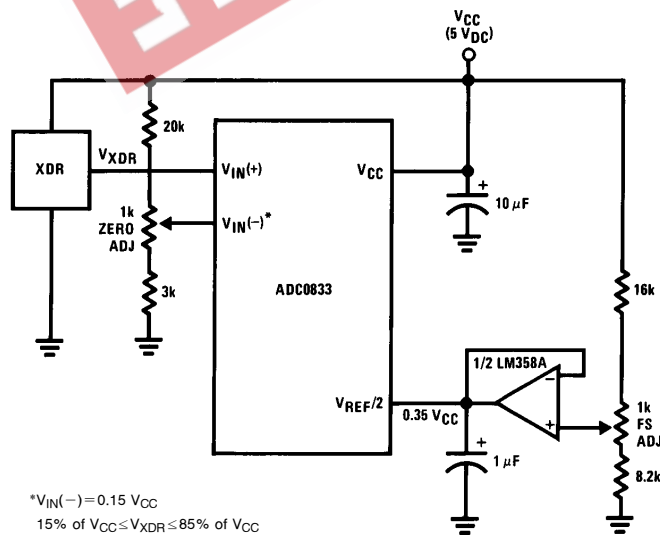

\* $V_{IN(-)} = 0.15 V_{CC}$   
 $15\% \text{ of } V_{CC} \leq V_{XDR} \leq 85\% \text{ of } V_{CC}$

TL/H/5607-12



## Applications (Continued)

Span Adjust:  $0V \leq V_{IN} \leq 3V$

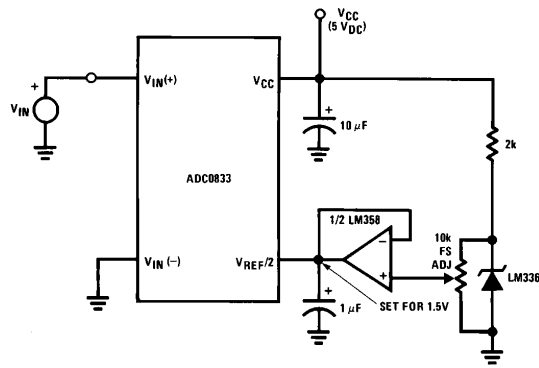

TL/H/5607-18

Zero-Shift and Span Adjust:  $2V \leq V_{IN} \leq 5V$

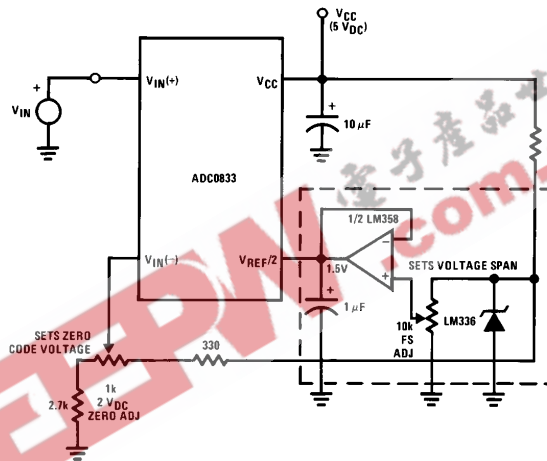

TL/H/5607-19

Protecting the Input

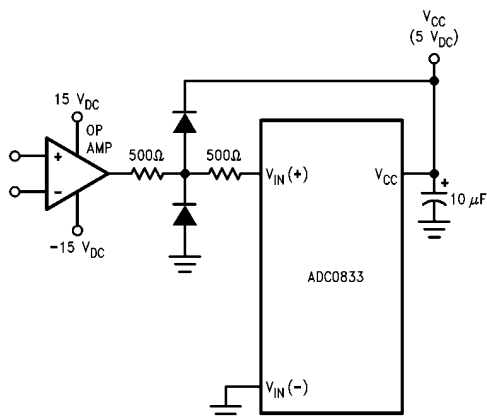

Diodes are 1N914

TL/H/5607-20

For additional application ideas, refer to the data sheet for the ADC0831 family of serial data converters.

High Accuracy Comparators

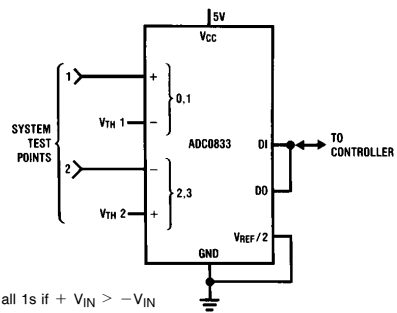

DO = all 1s if  $V_{IN} > -V_{IN}$   
DO = all 0s if  $V_{IN} < -V_{IN}$

TL/H/5607-13

## Ordering Information

Part Number	Temperature Range	Total Unadjusted Error
ADC0833BCN	0°C to +70°C	$\pm 1/2$ LSB
ADC0833CCJ	-40°C to +85°C	$\pm 1$ LSB
ADC0833CCN	0°C to +70°C	

EEPW 电子产品世界  
.com.cn

**Physical Dimensions** inches (millimeters)

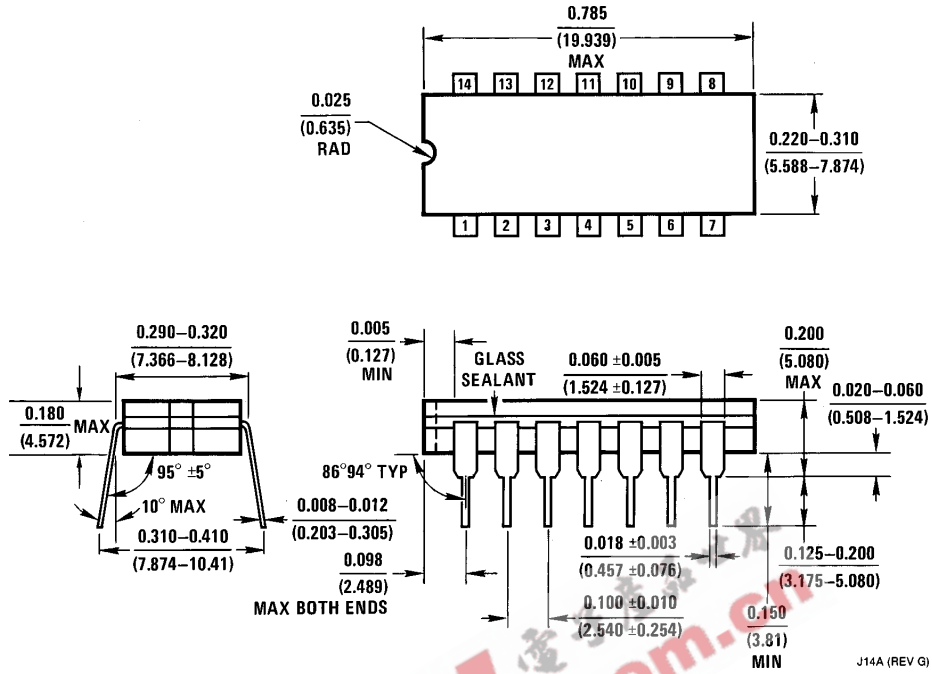

Ceramic Dual-In-Line Package (J)  
Order Number ADC0833CCJ  
NS Package Number J14A

J14A (REV G)

**Physical Dimensions** inches (millimeters) (Continued)

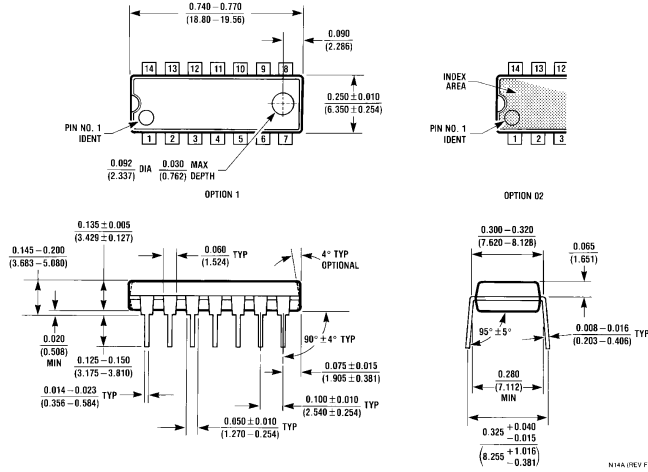

**Molded Dual-In-Line Package (N)**  
**Order Number ADC0833BCN or ADC0833CCN**  
**NS Package Number N14A**

**LIFE SUPPORT POLICY**

NATIONAL'S PRODUCTS ARE NOT AUTHORIZED FOR USE AS CRITICAL COMPONENTS IN LIFE SUPPORT DEVICES OR SYSTEMS WITHOUT THE EXPRESS WRITTEN APPROVAL OF THE PRESIDENT OF NATIONAL SEMICONDUCTOR CORPORATION. As used herein:

1. Life support devices or systems are devices or systems which, (a) are intended for surgical implant into the body, or (b) support or sustain life, and whose failure to perform, when properly used in accordance with instructions for use provided in the labeling, can be reasonably expected to result in a significant injury to the user.
2. A critical component is any component of a life support device or system whose failure to perform can be reasonably expected to cause the failure of the life support device or system, or to affect its safety or effectiveness.



**National Semiconductor Corporation**  
 1111 West Bardin Road  
 Arlington, TX 76017  
 Tel: 1(800) 272-9959  
 Fax: 1(800) 737-7018

**National Semiconductor Europe**  
 Fax: (+49) 0-180-530 85 86  
 Email: cnjwge@levm2.nsc.com  
 Deutsch Tel: (+49) 0-180-530 85 85  
 English Tel: (+49) 0-180-532 78 32  
 Français Tel: (+49) 0-180-532 93 58  
 Italiano Tel: (+49) 0-180-534 16 80

**National Semiconductor Hong Kong Ltd.**  
 13th Floor, Straight Block,  
 Ocean Centre, 5 Canton Rd.  
 Tsimshatsui, Kowloon  
 Hong Kong  
 Tel: (852) 2737-1600  
 Fax: (852) 2736-9960

**National Semiconductor Japan Ltd.**  
 Tel: 81-043-299-2309  
 Fax: 81-043-299-2408

National does not assume any responsibility for use of any circuitry described, no circuit patent licenses are implied and National reserves the right at any time without notice to change said circuitry and specifications.