

DATA SHEET

For a complete data sheet, please also download:

- The IC06 74HC/HCT/HCU/HCMOS Logic Family Specifications
- The IC06 74HC/HCT/HCU/HCMOS Logic Package Information
- The IC06 74HC/HCT/HCU/HCMOS Logic Package Outlines

EEPW 电子产品世界
.com.cn

74HC/HCT191

Presettable synchronous 4-bit
binary up/down counter

Product specification
File under Integrated Circuits, IC06

December 1990

Presettable synchronous 4-bit binary up/down counter

74HC/HCT191

FEATURES

- Synchronous reversible counting
- Asynchronous parallel load
- Count enable control for synchronous expansion
- Single up/down control input
- Output capability: standard
- I_{CC} category: MSI

GENERAL DESCRIPTION

The 74HC/HCT191 are high-speed Si-gate CMOS devices and are pin compatible with low power Schottky TTL (LSTTL). They are specified in compliance with JEDEC standard no. 7A.

The 74HC/HCT191 are asynchronously presettable 4-bit binary up/down counters. They contain four master/slave flip-flops with internal gating and steering logic to provide asynchronous preset and synchronous count-up and count-down operation.

Asynchronous parallel load capability permits the counter to be preset to any desired number. Information present on the parallel data inputs (D_0 to D_3) is loaded into the counter and appears on the outputs when the parallel load (\overline{PL}) input is LOW. As indicated in the function table, this operation overrides the counting function.

Counting is inhibited by a HIGH level on the count enable (\overline{CE}) input. When \overline{CE} is LOW internal state changes are initiated synchronously by the LOW-to-HIGH transition of the clock input. The up/down ($\overline{U/D}$) input signal determines the direction of counting as indicated in the function table. The \overline{CE} input may go LOW when the clock is in either state, however, the LOW-to-HIGH \overline{CE} transition must occur only when the clock is HIGH. Also, the $\overline{U/D}$ input should be changed only when either \overline{CE} or CP is HIGH.

Overflow/underflow indications are provided by two types of outputs, the terminal count (TC) and ripple clock (\overline{RC}). The TC output is normally LOW and goes HIGH when a circuit reaches zero in the count-down mode or reaches "15" in the count-up-mode. The TC output will remain HIGH until a state change occurs, either by counting or presetting, or until $\overline{U/D}$ is changed. Do not use the TC output as a clock signal because it is subject to decoding spikes. The TC signal is used internally to enable the \overline{RC} output. When TC is HIGH and \overline{CE} is LOW, the \overline{RC} output follows the clock pulse (CP). This feature simplifies the design of multistage counters as shown in Figs 5 and 6.

In Fig.5, each \overline{RC} output is used as the clock input to the next higher stage. It is only necessary to inhibit the first stage to prevent counting in all stages, since a HIGH on \overline{CE} inhibits the \overline{RC} output pulse as indicated in the function table. The timing skew between state changes in the first and last stages is represented by the cumulative delay of the clock as it ripples through the preceding stages. This can be a disadvantage of this configuration in some applications.

Fig.6 shows a method of causing state changes to occur simultaneously in all stages. The \overline{RC} outputs propagate the carry/borrow signals in ripple fashion and all clock inputs are driven in parallel. In this configuration the duration of the clock LOW state must be long enough to allow the negative-going edge of the carry/borrow signal to ripple through to the last stage before the clock goes HIGH. Since the \overline{RC} output of any package goes HIGH shortly after its CP input goes HIGH there is no such restriction on the HIGH-state duration of the clock.

In Fig.7, the configuration shown avoids ripple delays and their associated restrictions. Combining the TC signals from all the preceding stages forms the \overline{CE} input for a given stage. An enable must be included in each carry gate in order to inhibit counting. The TC output of a given stage is not affected by its own \overline{CE} signal therefore the simple inhibit scheme of Figs 5 and 6 does not apply.

Pre-settable synchronous 4-bit binary up/down counter

74HC/HCT191

QUICK REFERENCE DATAGND = 0 V; $T_{amb} = 25\text{ }^{\circ}\text{C}$; $t_r = t_f = 6\text{ ns}$

SYMBOL	PARAMETER	CONDITIONS	TYPICAL		UNIT
			HC	HCT	
t_{PHL}/t_{PLH}	propagation delay CP to Q_n	$C_L = 15\text{ pF}$; $V_{CC} = 5\text{ V}$	22	22	ns
f_{max}	maximum clock frequency		36	36	MHz
C_I	input capacitance		3.5	3.5	pF
C_{PD}	power dissipation capacitance per package	notes 1 and 2	31	33	pF

Notes

- C_{PD} is used to determine the dynamic power dissipation (P_D in μW):

$$P_D = C_{PD} \times V_{CC}^2 \times f_i + \sum (C_L \times V_{CC}^2 \times f_o) \text{ where:}$$

f_i = input frequency in MHz

f_o = output frequency in MHz

$\sum (C_L \times V_{CC}^2 \times f_o)$ = sum of outputs

C_L = output load capacitance in pF

V_{CC} = supply voltage in V

- For HC the condition is $V_I = \text{GND to } V_{CC}$
For HCT the condition is $V_I = \text{GND to } V_{CC} - 1.5\text{ V}$

ORDERING INFORMATION

See "74HC/HCT/HCU/HCMOS Logic Package Information".

Pre-settable synchronous 4-bit binary up/down counter

74HC/HCT191

PIN DESCRIPTION

PIN NO.	SYMBOL	NAME AND FUNCTION
3, 2, 6, 7	Q ₀ to Q ₃	flip-flop outputs
4	\overline{CE}	count enable input (active LOW)
5	$\overline{U/D}$	up/down input
8	GND	ground (0 V)
11	\overline{PL}	parallel load input (active LOW)
12	TC	terminal count output
13	\overline{RC}	ripple clock output (active LOW)
14	CP	clock input (LOW-to-HIGH, edge triggered)
15, 1, 10, 9	D ₀ to D ₃	data inputs
16	V _{CC}	positive supply voltage

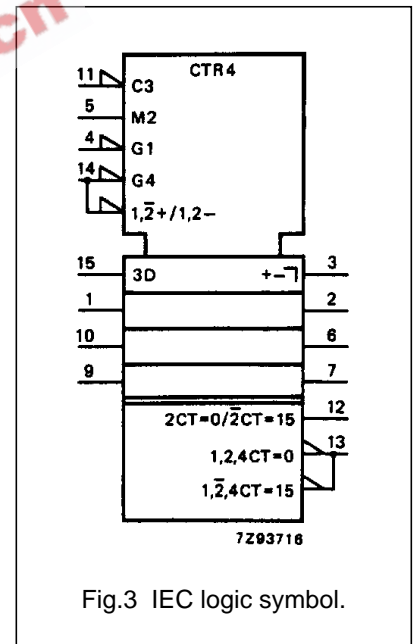
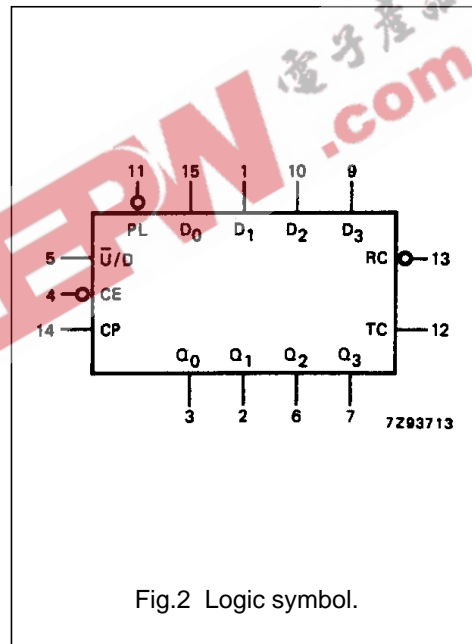
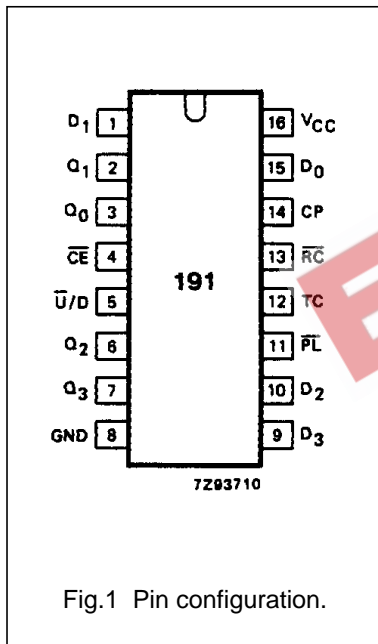

Pre-settable synchronous 4-bit binary up/down counter

74HC/HCT191

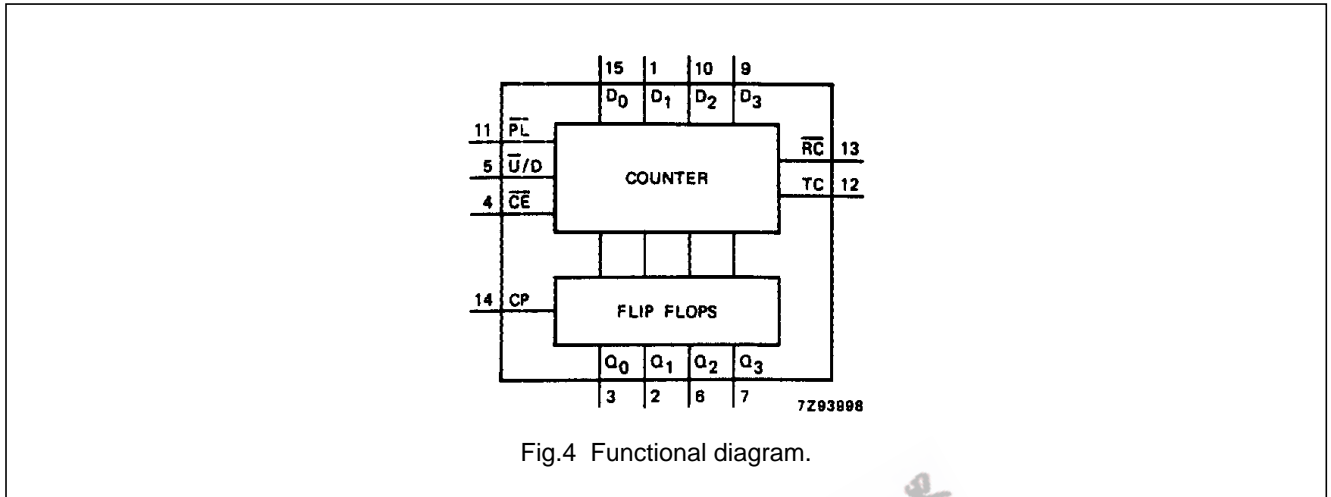

Fig.4 Functional diagram.

FUNCTION TABLE

OPERATING MODE	INPUTS					D _n	Q _n
	PL	U/D	CE	CP	D _n		
parallel load	L	X	X	X	L	L	
	L	X	X	X	H	H	
count up	H	L	I	↑	X	count up	
count down	H	H	I	↑	X	count down	
hold (do nothing)	H	X	H	X	X	no change	

TC AND RC FUNCTION TABLE

INPUTS			TERMINAL COUNT STATE				OUTPUTS	
U/D	CE	CP	Q ₀	Q ₁	Q ₂	Q ₃	TC	RC
H	H	X	H	H	H	H	L	H
L	H	X	H	H	H	H	H	H
L	L	⌊	H	H	H	H	⌋	⌊
L	H	X	L	L	L	L	L	H
H	H	X	L	L	L	L	H	H
H	L	⌊	L	L	L	L	⌋	⌊

Notes

- H = HIGH voltage level
 L = LOW voltage level
 I = LOW voltage level one set-up time prior to the LOW-to-HIGH CP transition
 X = don't care
 ↑ = LOW-to-HIGH CP transition
 ⌊ = one LOW level pulse
 ⌋ = TC goes LOW on a LOW-to-HIGH CP transition

Presettable synchronous 4-bit binary up/down counter

74HC/HCT191

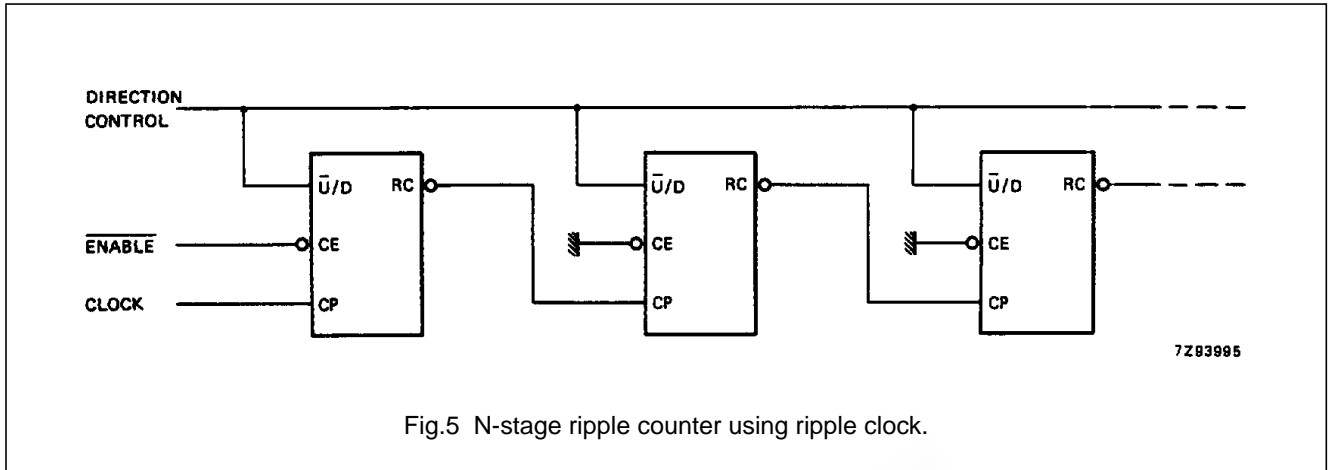

Fig.5 N-stage ripple counter using ripple clock.

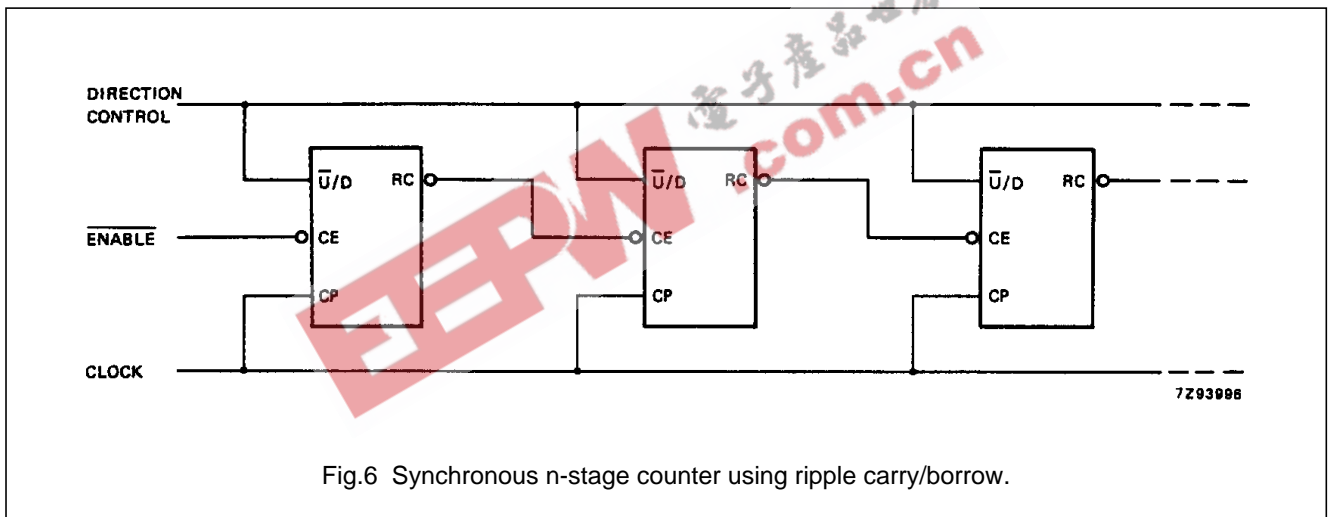

Fig.6 Synchronous n-stage counter using ripple carry/borrow.

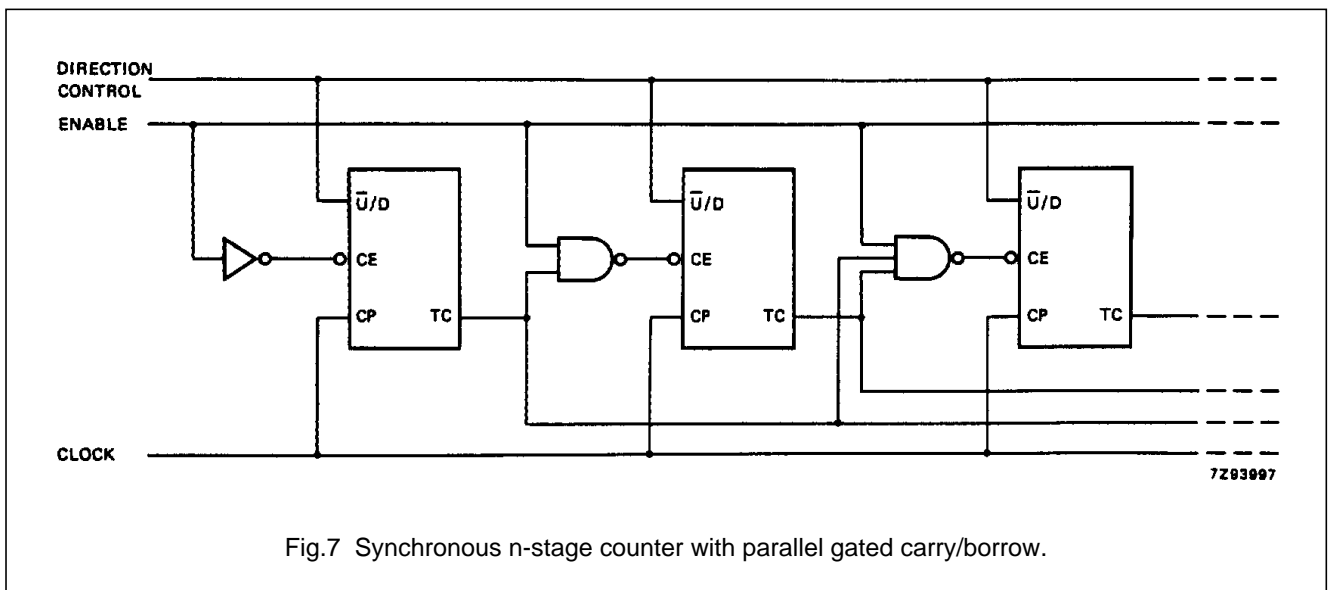

Fig.7 Synchronous n-stage counter with parallel gated carry/borrow.

Pre-settable synchronous 4-bit binary up/down counter

74HC/HCT191

Sequence

Load (preset) to binary thirteen;
 count up to fourteen, fifteen,
 zero, one and two;
 inhibit;
 count down to one, zero, fifteen,
 fourteen and thirteen.

Fig.8 Typical load, count and inhibit sequence.

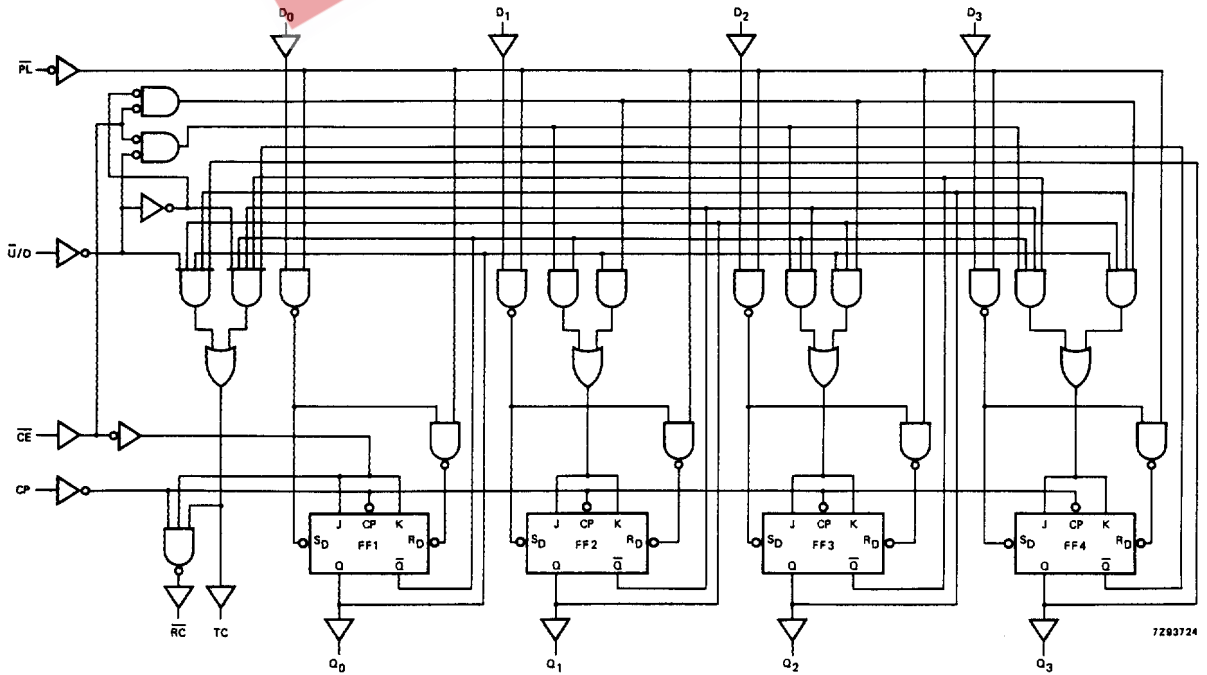
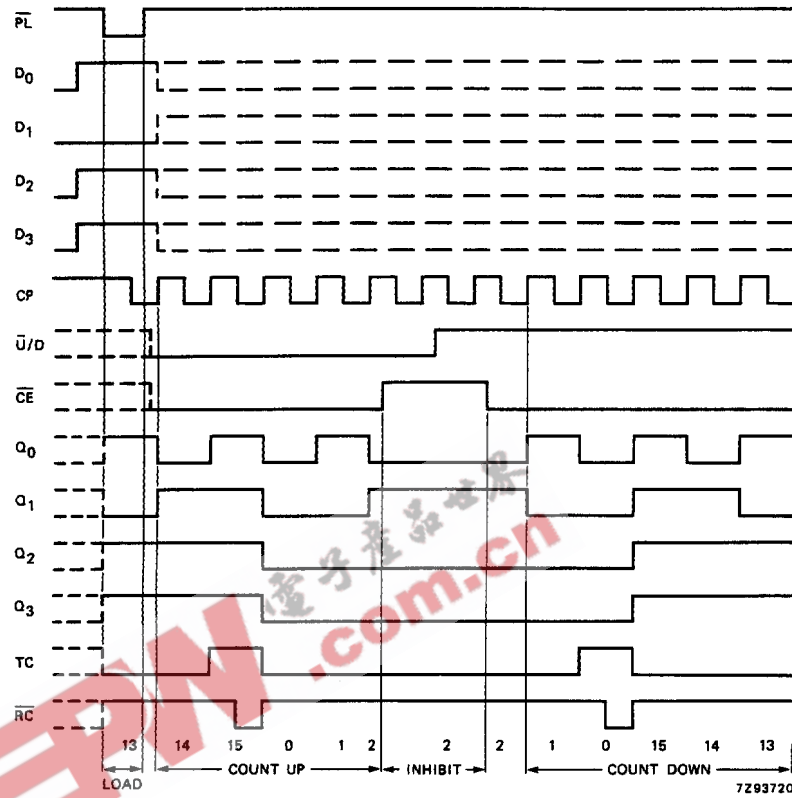

Fig.9 Logic diagram.

Presetable synchronous 4-bit binary up/down counter

74HC/HCT191

DC CHARACTERISTICS FOR 74HC

For the DC characteristics see *"74HC/HCT/HCU/HCMOS Logic Family Specifications"*.

Output capability: standard

I_{CC} category: MSI

AC CHARACTERISTICS FOR 74HC

GND = 0 V; t_r = t_f = 6 ns; C_L = 50 pF

SYMBOL	PARAMETER	T _{amb} (°C)						UNIT	TEST CONDITIONS	
		74HC							V _{CC} (V)	WAVEFORMS
		+25			-40 to +85		-40 to +125			
		min.	typ.	max.	min.	max.	min.			
t _{PHL} / t _{PLH}	propagation delay CP to Q _n		72 26 21	220 44 37		275 55 47	330 66 56	ns	2.0 4.5 6.0	Fig.10
t _{PHL} / t _{PLH}	propagation delay CP to TC		83 30 24	255 51 43		320 64 54	395 77 65	ns	2.0 4.5 6.0	Fig.10
t _{PHL} / t _{PLH}	propagation delay CP to \overline{RC}		47 17 14	150 30 26		190 38 33	225 45 38	ns	2.0 4.5 6.0	Fig.11
t _{PHL} / t _{PLH}	propagation delay CE to RC		33 12 10	130 26 22		165 33 28	195 39 33	ns	2.0 4.5 6.0	Fig.11
t _{PHL} / t _{PLH}	propagation delay D _n to Q _n		61 22 18	220 44 37		275 55 47	330 66 56	ns	2.0 4.5 6.0	Fig.12
t _{PHL} / t _{PLH}	propagation delay \overline{PL} to Q _n		61 22 18	220 44 37		275 55 47	330 66 56	ns	2.0 4.5 6.0	Fig.13
t _{PHL} / t _{PLH}	propagation delay U/D to TC		44 16 13	190 38 32		240 48 41	285 57 48	ns	2.0 4.5 6.0	Fig.14
t _{PHL} / t _{PLH}	propagation delay $\overline{U/D}$ to \overline{RC}		50 18 14	210 42 36		265 53 45	315 63 54	ns	2.0 4.5 6.0	Fig.14
t _{THL} / t _{TLH}	output transition time		19 7 6	75 15 13		95 19 16	110 22 19	ns	2.0 4.5 6.0	Fig.15
t _w	clock pulse width HIGH or LOW	125 25 21	28 10 8		155 31 26		195 39 33	ns	2.0 4.5 6.0	Fig.10
t _w	parallel load pulse width LOW	100 20 17	22 8 6		125 25 21		150 30 26	ns	2.0 4.5 6.0	Fig.15

Pre-settable synchronous 4-bit binary up/down counter

74HC/HCT191

SYMBOL	PARAMETER	T _{amb} (°C)							UNIT	TEST CONDITIONS	
		74HC								V _{CC} (V)	WAVEFORMS
		+25			-40 to +85		-40 to +125				
		min.	typ.	max.	min.	max.	min.	max.			
t _{rem}	removal time \overline{PL} to CP	35 7 6	8 3 2		45 9 8		55 11 9		ns	2.0 4.5 6.0	Fig.15
t _{su}	set-up time $\overline{U/D}$ to CP	205 41 35	50 18 14		255 51 43		310 62 53		ns	2.0 4.5 6.0	Fig.17
t _{su}	set-up time D _n to \overline{PL}	100 20 17	19 7 6		125 25 21		150 30 26		ns	2.0 4.5 6.0	Fig.16
t _{su}	set-up time \overline{CE} to CP	140 28 24	44 16 13		175 35 30		210 42 36		ns	2.0 4.5 6.0	Fig.17
t _h	hold time $\overline{U/D}$ to CP	0 0 0	-39 -14 -11		0 0 0		0 0 0		ns	2.0 4.5 6.0	Fig.17
t _h	hold time D _n to \overline{PL}	0 0 0	-11 -4 -3		0 0 0		0 0 0		ns	2.0 4.5 6.0	Fig.16
t _h	hold time \overline{CE} to CP	0 0 0	-28 -10 -8		0 0 0		0 0 0		ns	2.0 4.5 6.0	Fig.17
f _{max}	maximum clock pulse frequency	4.0 20 24	11 33 39		3.2 16 19		2.6 13 15		MHz	2.0 4.5 6.0	Fig.10

**Pre-settable synchronous 4-bit binary
up/down counter**

74HC/HCT191**DC CHARACTERISTICS FOR 74HCT**

For the DC characteristics see *"74HC/HCT/HCU/HCMOS Logic Family Specifications"*.

Output capability: standard

I_{CC} category: MSI

Note to HCT types

The value of additional quiescent supply current (ΔI_{CC}) for a unit load of 1 is given in the family specifications. To determine ΔI_{CC} per input, multiply this value by the unit load coefficient shown in the table below.

INPUT	UNIT LOAD COEFFICIENT
D _n	0.5
CP	0.65
$\overline{U/D}$	1.15
$\overline{CE}, \overline{PL}$	1.5

EEPW 电子产品世界
.com.cn

Presettable synchronous 4-bit binary up/down counter

74HC/HCT191

AC CHARACTERISTICS FOR 74HCTGND = 0 V; $t_r = t_f = 6$ ns; $C_L = 50$ pF

SYMBOL	PARAMETER	T_{amb} (°C)						UNIT	TEST CONDITIONS		
		74HC							V_{CC} (V)	WAVEFORMS	
		+25			-40 to +85		-40 to +125				
		min.	typ.	max.	min.	max.	min.				max.
t_{PHL}/t_{PLH}	propagation delay CP to Q_n		26	48		60		72	ns	4.5	Fig.10
t_{PHL}/t_{PLH}	propagation delay CP to TC		32	51		64		77	ns	4.5	Fig.10
t_{PHL}/t_{PLH}	propagation delay CP to \overline{RC}		19	35		44		53	ns	4.5	Fig.11
t_{PHL}/t_{PLH}	propagation delay CE to \overline{RC}		19	33		41		50	ns	4.5	Fig.11
t_{PHL}/t_{PLH}	propagation delay D_n to Q_n		22	44		55		66	ns	4.5	Fig.12
t_{PHL}/t_{PLH}	propagation delay PL to Q_n		27	46		58		69	ns	4.5	Fig.13
t_{PHL}/t_{PLH}	propagation delay $\overline{U/D}$ to TC		23	45		56		68	ns	4.5	Fig.14
t_{PHL}/t_{PLH}	propagation delay $\overline{U/D}$ to \overline{RC}		24	45		56		68	ns	4.5	Fig.14
t_{THL}/t_{TLH}	output transition time		7	15		19		22	ns	4.5	Fig.15
t_W	clock pulse width HIGH or LOW	16	9		20		24		ns	4.5	Fig.10
t_W	parallel load pulse width LOW	22	11		28		33		ns	4.5	Fig.15
t_{rem}	removal time \overline{PL} to CP	7	1		9		11		ns	4.5	Fig.15
t_{su}	set-up time $\overline{U/D}$ to CP	41	20		51		62		ns	4.5	Fig.17
t_{su}	set-up time D_n to \overline{PL}	20	9		25		30		ns	4.5	Fig.16
t_{su}	set-up time \overline{CE} to CP	30	18		38		45		ns	4.5	Fig.17
t_h	hold time $\overline{U/D}$ to CP	0	-18		0		0		ns	4.5	Fig.17
t_h	hold time D_n to \overline{PL}	0	-5		0		0		ns	4.5	Fig.16
t_h	hold time CE to CP	0	-10		0		0		ns	4.5	Fig.17
f_{max}	maximum clock pulse frequency	20	33		16		13		MHz	4.5	Fig.10

Pre-settable synchronous 4-bit binary up/down counter

74HC/HCT191

AC WAVEFORMS

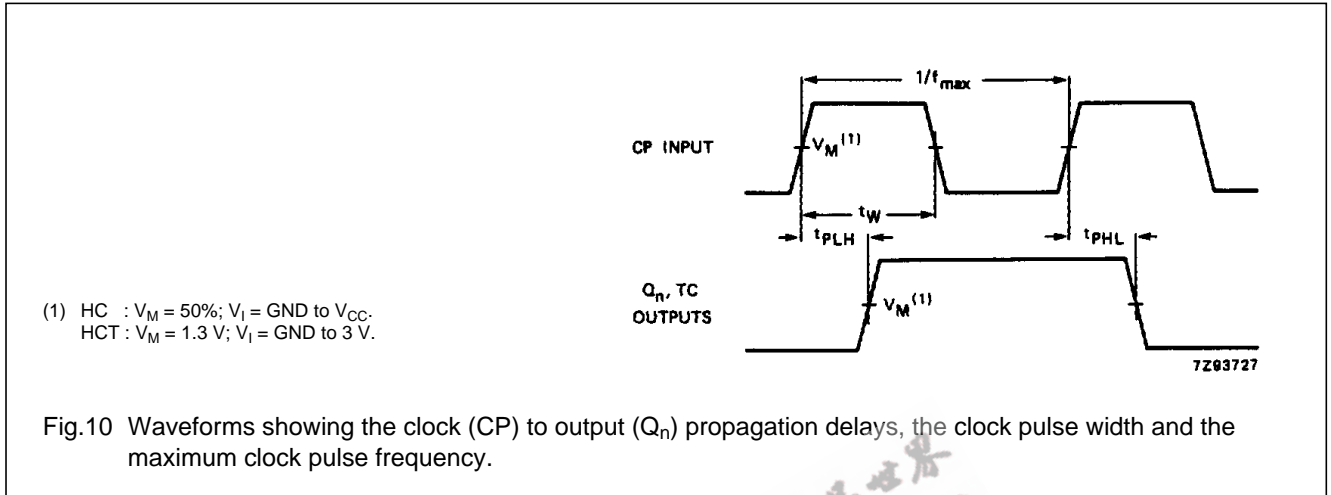

Fig.10 Waveforms showing the clock (CP) to output (Q_n) propagation delays, the clock pulse width and the maximum clock pulse frequency.

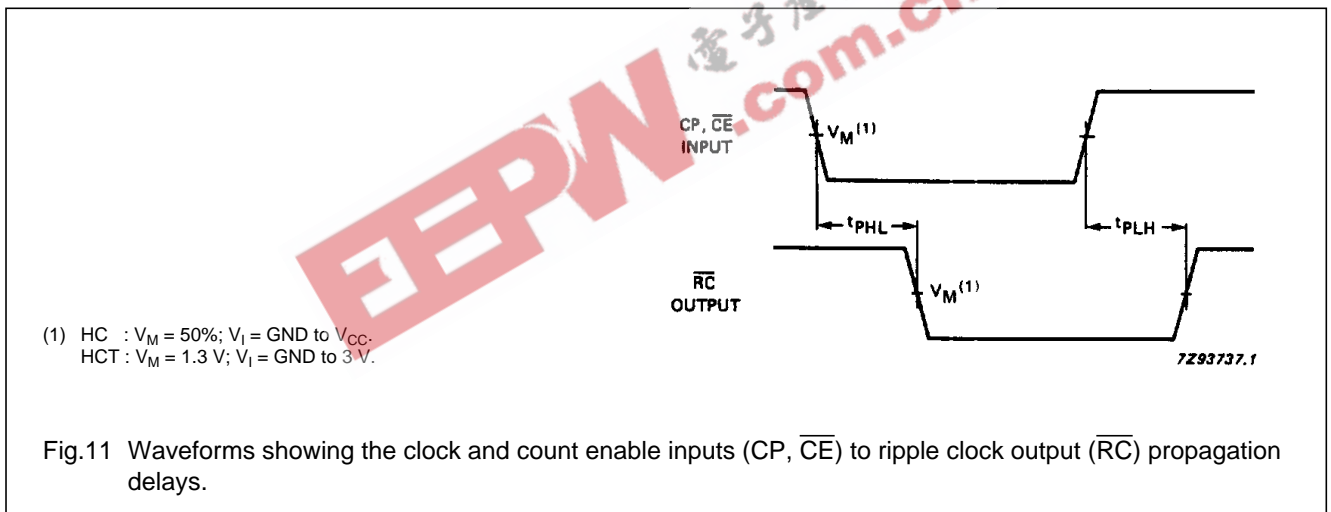

Fig.11 Waveforms showing the clock and count enable inputs (CP, \overline{CE}) to ripple clock output (\overline{RC}) propagation delays.

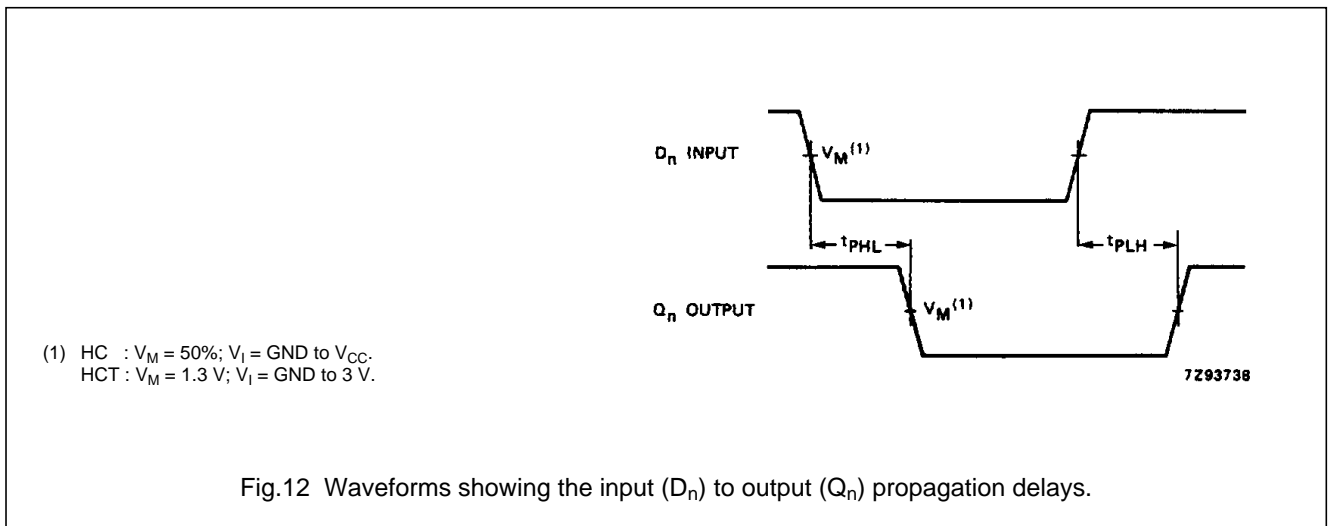

Fig.12 Waveforms showing the input (D_n) to output (Q_n) propagation delays.

Pre-settable synchronous 4-bit binary up/down counter

74HC/HCT191

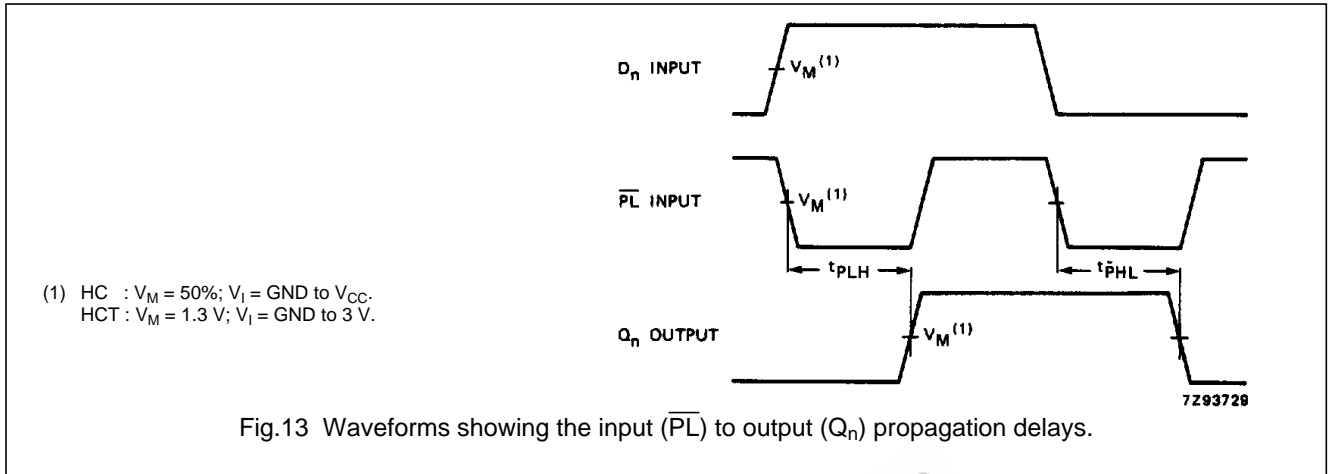

Fig.13 Waveforms showing the input (\overline{PL}) to output (Q_n) propagation delays.

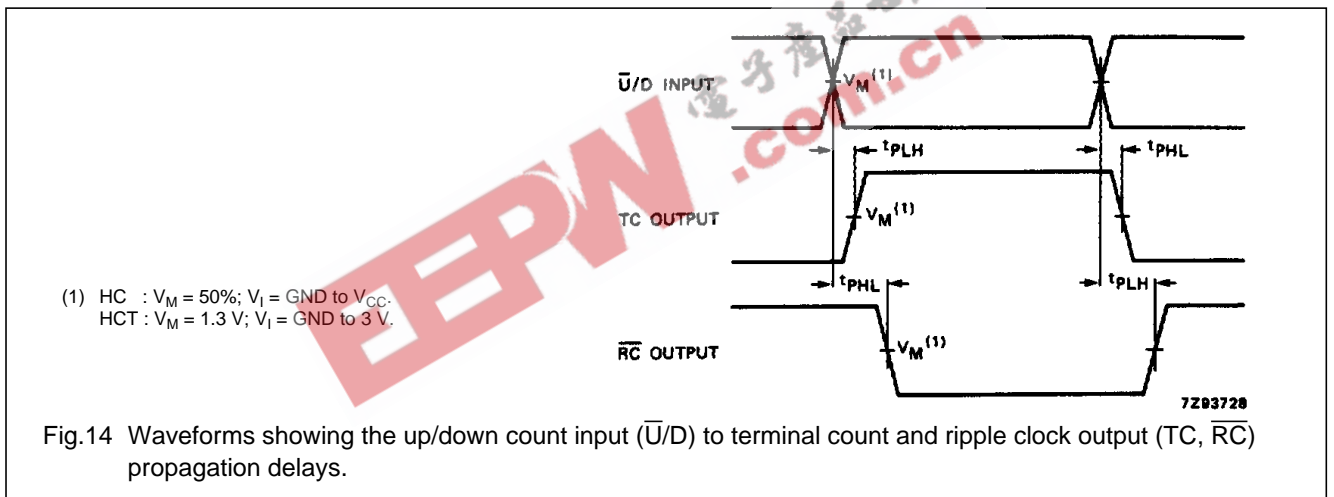

Fig.14 Waveforms showing the up/down count input ($\overline{U/D}$) to terminal count and ripple clock output (TC , \overline{RC}) propagation delays.

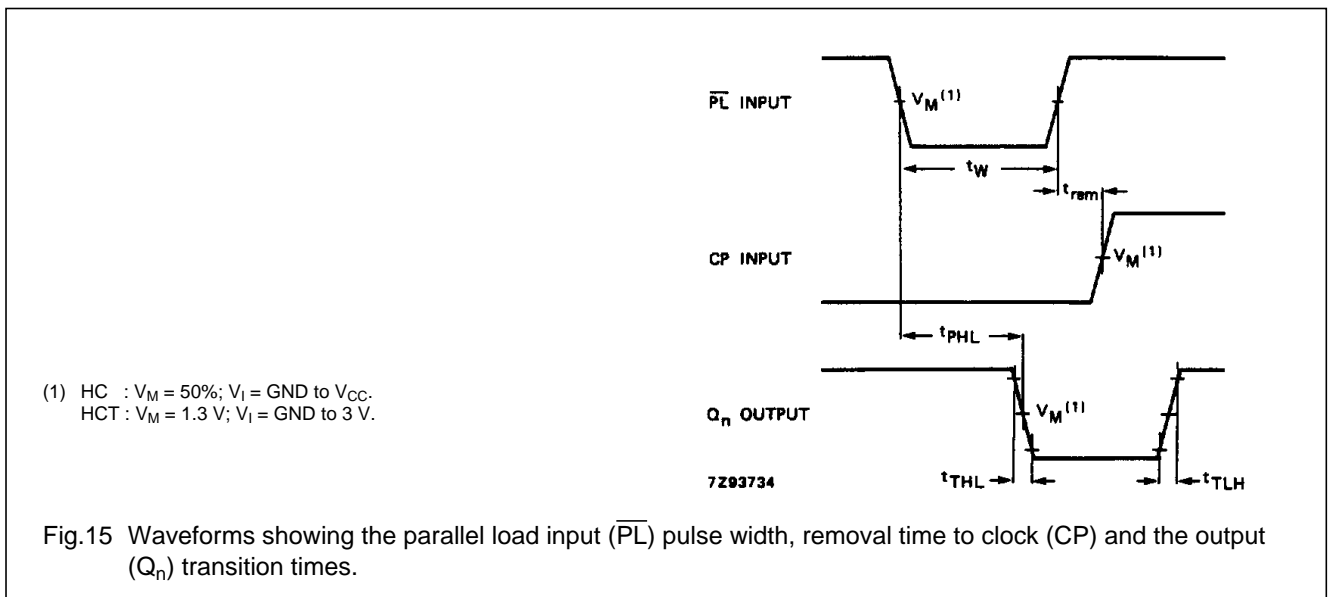

Fig.15 Waveforms showing the parallel load input (\overline{PL}) pulse width, removal time to clock (CP) and the output (Q_n) transition times.

Pre-settable synchronous 4-bit binary up/down counter

74HC/HCT191

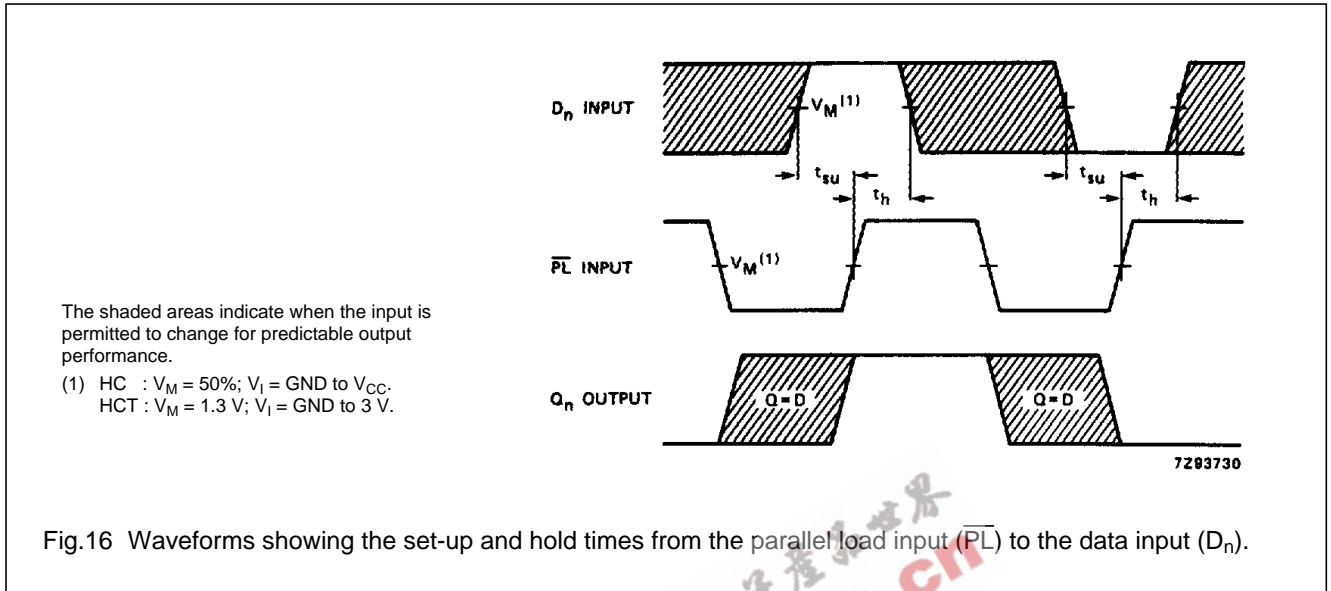

Fig.16 Waveforms showing the set-up and hold times from the parallel load input ($\overline{\text{PL}}$) to the data input (D_n).

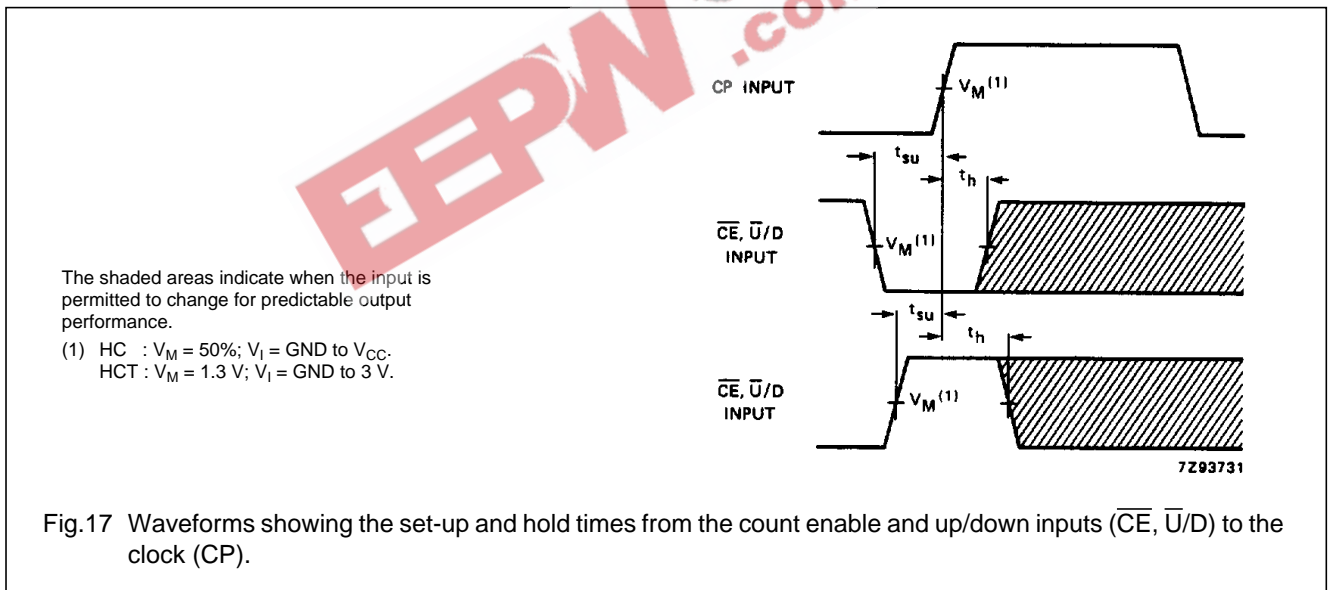

Fig.17 Waveforms showing the set-up and hold times from the count enable and up/down inputs ($\overline{\text{CE}}$, $\overline{\text{U/D}}$) to the clock (CP).

PACKAGE OUTLINES

See "74HC/HCT/HCU/HCMOS Logic Package Outlines".