

# DATA SHEET

EEPW 电子產品世界  
.com.cn

**74F786**

4-bit asynchronous bus arbiter

Product specification

1991 Feb 14

IC15 Data Handbook

# 4-bit asynchronous bus arbiter

# 74F786

## FEATURES

- Arbitrates between 4 asynchronous inputs
- Separate grant output for each input
- Common output enable
- On board 4 input AND gate
- Metastable-free outputs
- Industrial temperature range available (-40°C to +85°C)

## DESCRIPTION

The 74F786 is an asynchronous 4-bit arbiter designed for high speed real-time applications. The priority of arbitration is determined on a first-come first-served basis. Separate bus grant ( $\overline{BG}_n$ ) outputs are available to indicate which one of the request inputs is served by the arbitration logic. All  $\overline{BG}_n$  outputs are enabled by a common enable ( $\overline{EN}$ ) pin. In order to generate a bus request signal a separate 4 input AND gate is provided which may also be used as an independent AND gate. Unused bus request ( $\overline{BR}$ ) inputs may be disabled by tying them high.

The 74F786 is designed so that contention between two or more request signals will not glitch or display a metastable condition. In this situation an increase in the  $\overline{BR}_n$  to  $\overline{BG}_n$   $t_{PHL}$  may be observed. A typical 74F786 has an  $h = 6.6ns$ ,  $t = 0.41ns$  and  $T_o = 5\mu sec$ .

Where:

$h$  = Typical propagation delay through the device and  $t$  and  $T_o$  are device parameters derived from test results and can most nearly be defined as:

$t$  = A function of the rate at which a latch in a metastable state resolves that condition.

$T_o$  = A function of the measurement of the propensity of a latch to enter a metastable state.  $T_o$  is also a very strong function of the normal propagation delay of the device.

For further information, please refer to the 74F786 application notes.

TYPE	TYPICAL PROPAGATION DELAY	TYPICAL SUPPLY CURRENT (TOTAL)
74F786	6.6ns	55mA

## ORDERING INFORMATION

DESCRIPTION	ORDER CODE		PKG DWG #
	COMMERCIAL RANGE $V_{CC} = 5V \pm 10\%$ , $T_{amb} = 0^\circ C$ to $+70^\circ C$	INDUSTRIAL RANGE $V_{CC} = 5V \pm 10\%$ , $T_{amb} = -40^\circ C$ to $+85^\circ C$	
16-pin plastic DIP	N74F786N	I74F786N	SOT 38-4
16-pin plastic SO	N74F786D	I74F786D	SOT109-1

## INPUT AND OUTPUT LOADING AND FAN OUT TABLE

PINS	DESCRIPTION	74F (U.L.) HIGH/LOW	LOAD VALUE HIGH/LOW
$\overline{BR}_0 - \overline{BR}_3$	Bus request inputs (active low)	1.0/3.0	20 $\mu$ A/1.8mA
A, B, C, D	AND gate inputs	1.0/1.0	20 $\mu$ A/0.6mA
$\overline{EN}$	Common bus grant output enable input (active low)	1.0/1.0	20 $\mu$ A/0.6mA
YOUT	AND gate output	150/40	3.0mA/24mA
$\overline{BG}_0 - \overline{BG}_3$	Bus grant outputs (active low)	150/40	3.0mA/24mA

### NOTE:

One (1.0) FAST unit load is defined as: 20 $\mu$ A in the high state and 0.6mA in the low state.

## LOGIC SYMBOL

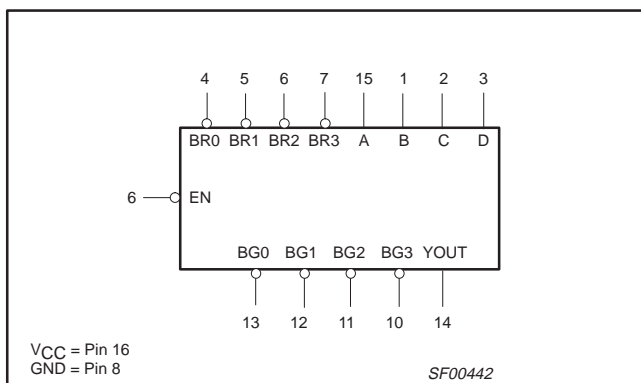

## IEC/IEEE SYMBOL

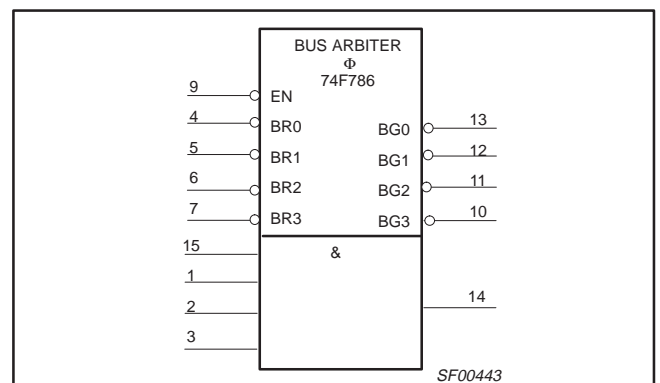

## 4-bit asynchronous bus arbiter

74F786

## FUNCTIONAL DESCRIPTION

The  $\overline{BR}_n$  inputs have no inherent priority. The arbiter assigns priority to the incoming requests as they are received, therefore, the first  $\overline{BR}$  asserted will have the highest priority. When a bus request is received its corresponding bus grant becomes active, provided that  $\overline{EN}$  is low. If additional bus requests are made during this time they are queued. When the first request is removed, the arbiter services the bus request with the next highest priority. Removing a request while a previous request is being serviced can cause a grant to be changed when arbitrating between three or four requests. For that reason, the user should not remove ungranted requests when arbitrating between three or four requests. This does not apply to arbitration between two requests.

If two or more  $\overline{BR}_n$  inputs are asserted at precisely the same time, one of them will be selected at random, and all  $\overline{BG}_n$  outputs will be held in the high state until the selection is made. This guarantees that an erroneous  $\overline{BG}_n$  will not be generated even though a metastable condition may occur internal to the device. When the  $\overline{EN}$  is in the high state the  $\overline{BG}_n$  outputs are forced high.

## PIN CONFIGURATION

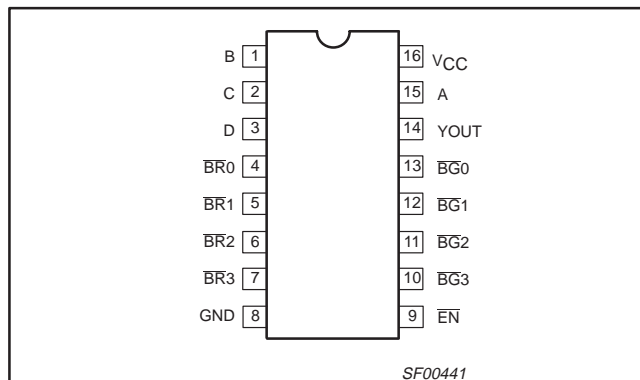

## PIN DESCRIPTION

SYMBOL	PINS	TYPE	NAME	FUNCTION
$\overline{BR}_0 - \overline{BR}_3$	4, 5, 6, 7	Input	Bus request inputs (active low)	The logic of this device arbitrates between these four inputs. Unused inputs should be tied high.
A, B, C, D	15, 1, 2, 3	Input	Inputs of the 4-input AND gate	
$\overline{EN}$	9	Input	Enable input	When low it enables the $\overline{BG}_0 - \overline{BG}_3$ outputs.
$\overline{BG}_0 - \overline{BG}_3$	13, 12, 11, 10	Output	Bus grant outputs (active low)	These outputs indicate the selected bus request. $\overline{BG}_0$ corresponds to $\overline{BR}_0$ , $\overline{BG}_1$ to $\overline{BR}_1$ , etc.
YOUT	14	Output	Output of the 4-input AND gate	
GND	8	Ground	ground (0V)	
$V_{CC}$	16	Power	Positive supply voltages	

## 4-bit asynchronous bus arbiter

74F786

## ARBITER FUNCTION TABLE

INPUTS					OUTPUTS			
EN	BR0	BR1	BR2	BR3	BG0	BG1	BG2	BG3
L	1	X	X	X	L	H	H	H
L	X	1	X	X	H	L	H	H
L	X	X	1	X	H	H	L	H
L	X	X	X	1	H	H	H	L
H	X	X	X	X	H	H	H	H

## Notes to mode selection function table

- H = High-voltage level  
 L = Low-voltage level  
 X = Don't care  
 1 = First of inputs to go low

## ARBITER FUNCTION TABLE

INPUTS				OUTPUT
A	B	C	D	YOUT
L	L	L	L	L
L	L	L	H	L
L	L	H	L	L
L	L	H	H	L
L	H	L	L	L
L	H	L	H	L
L	H	H	L	L
L	H	H	H	L
H	L	L	L	L
H	L	L	H	L
H	L	H	L	L
H	L	H	H	L
H	H	L	L	L
H	H	L	H	L
H	H	H	L	L
H	H	H	H	H

## Notes to AND function table

- H = High-voltage level  
 L = Low-voltage level

# 4-bit asynchronous bus arbiter

74F786

## LOGIC DIAGRAM

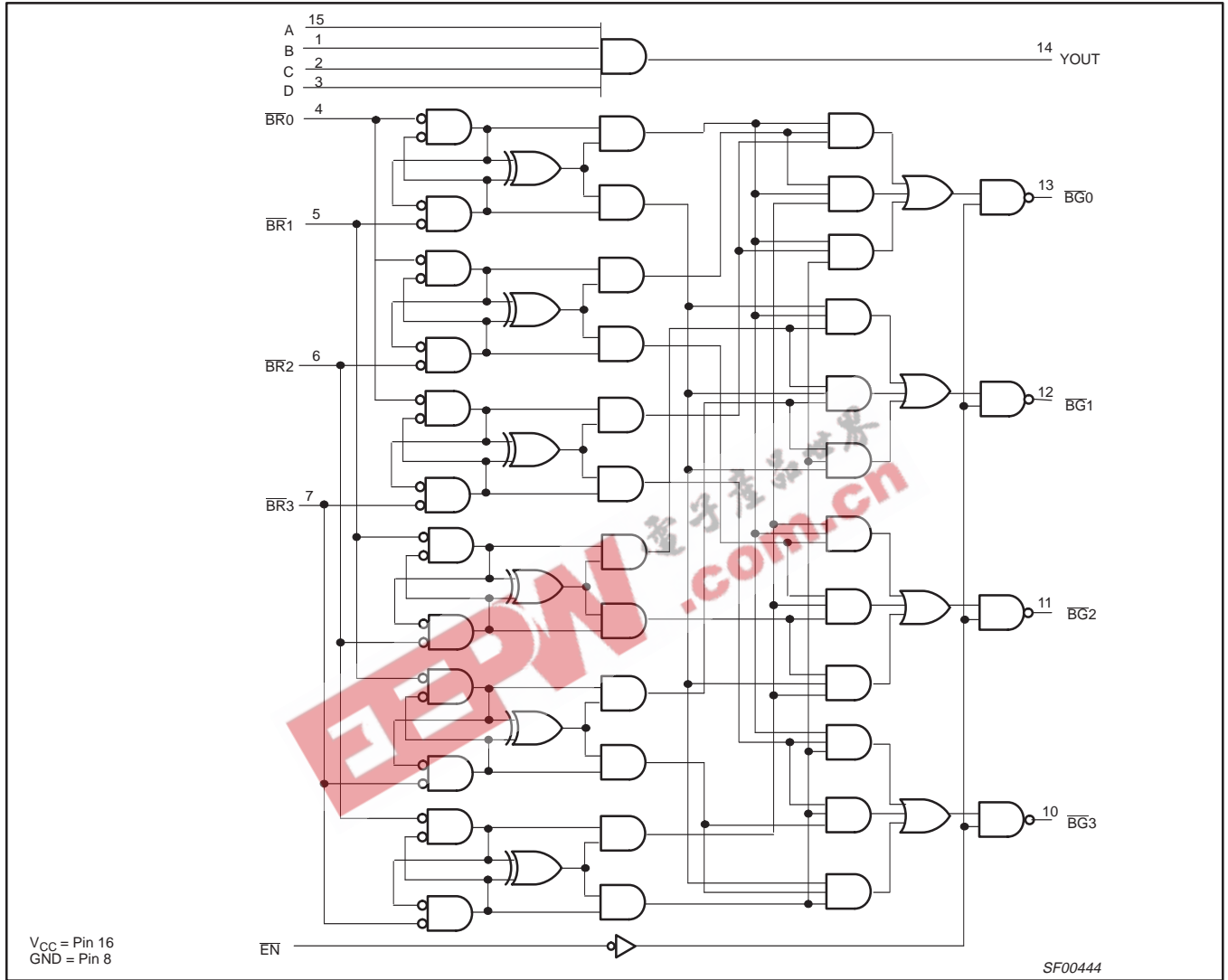

## ABSOLUTE MAXIMUM RATINGS

(Operation beyond the limit set forth in this table may impair the useful life of the device. Unless otherwise noted these limits are over the operating free air temperature range.)

SYMBOL	PARAMETER	RATING	UNIT
V <sub>CC</sub>	Supply voltage	-0.5 to +7.0	V
V <sub>IN</sub>	Input voltage	-0.5 to +7.0	V
I <sub>IN</sub>	Input current	-30 to +5	mA
V <sub>OUT</sub>	Voltage applied to output in high output state	-0.5 to V <sub>CC</sub>	V
I <sub>OUT</sub>	Current applied to output in low output state	48	mA
T <sub>amb</sub>	Operating free air temperature range	Commercial range	0 to +70 °C
		Industrial range	-40 to +85 °C
T <sub>stg</sub>	Storage temperature range	-65 to +150	°C

## 4-bit asynchronous bus arbiter

74F786

## RECOMMENDED OPERATING CONDITIONS

SYMBOL UNIT	PARAMETER	LIMITS			$T_A =$ -40 to +85°C
		MIN	NOM	MAX	
$V_{CC}$	Supply voltage	4.5	5.0	5.5	V
$V_{IN}$	High-level input voltage	2.0			V
$V_{IL}$	Low-level input voltage			0.8	V
$I_{IK}$	Input clamp current			-18	mA
$I_{OH}$	High-level output current			-1	mA
$I_{OL}$	Low-level output current			24	mA
$T_{amb}$	Operating free air temperature range	Commercial range	0	+70	°C
		Industrial range	-40	+85	°C

## DC ELECTRICAL CHARACTERISTICS

(Over recommended operating free-air temperature range unless otherwise noted.)

SYMBOL	PARAMETER	TEST CONDITIONS <sup>1</sup>	LIMITS			UNIT		
			MIN	TYP <sup>2</sup>	MAX			
$V_{OH}$	High-level output voltage	$V_{CC} = \text{MIN}, V_{IL} = \text{MAX}, V_{IH} = \text{MIN}$	$I_{OH} = \text{MAX}$	$\pm 10\%V_{CC}$	2.4		V	
				$\pm 5\%V_{CC}$	2.7	3.3	V	
$V_{OL}$	Low-level output voltage	$V_{CC} = \text{MIN}, V_{IL} = \text{MAX}, V_{IH} = \text{MIN}$	$I_{OL} = \text{MAX}$	$\pm 10\%V_{CC}$		0.30	0.50	V
				$\pm 5\%V_{CC}$		0.30	0.50	V
$V_{IK}$	Input clamp voltage	$V_{CC} = \text{MIN}, I_I = I_{IK}$			-0.73	-1.2	V	
$I_I$	Input current at maximum input voltage	$V_{CC} = 0.0V, V_I = 7.0V$				100	$\mu\text{A}$	
$I_{IH}$	High-level input current	$V_{CC} = \text{MAX}, V_I = 2.7V$				20	$\mu\text{A}$	
$I_{IL}$	Low-level input current	A – D, EN	$V_{CC} = \text{MAX}, V_I = 0.5V$			-0.6	mA	
		$\overline{\text{BR}}_n$				-1.8	mA	
$I_{OS}$	Short-circuit output current <sup>3</sup>	$V_{CC} = \text{MAX}$			-60	-150	mA	
$I_{CC}$	Supply current (total)	$V_{CC} = \text{MAX}$			55	80	mA	

## Notes to DC electrical characteristics

- For conditions shown as MIN or MAX, use the appropriate value specified under recommended operating conditions for the applicable type.
- All typical values are at  $V_{CC} = 5V, T_{amb} = 25^\circ\text{C}$ .
- Not more than one output should be shorted at a time. For testing  $I_{OS}$ , the use of high-speed test apparatus and/or sample-and-hold techniques are preferable in order to minimize internal heating and more accurately reflect operational values. Otherwise, prolonged shorting of a high output may raise the chip temperature well above normal and thereby cause invalid readings in other parameter tests. In any sequence of parameter tests,  $I_{OS}$  tests should be performed last.

4-bit asynchronous bus arbiter

74F786

AC ELECTRICAL CHARACTERISTICS

SYM-BOL	PARAMETER	TEST CONDITION	LIMITS								UNIT
			$T_{amb} = +25^{\circ}C$			$T_{amb} = 0^{\circ}C \text{ to } +70^{\circ}C$		$T_{amb} = -40^{\circ}C \text{ to } +85^{\circ}C$			
			$V_{CC} = +5.0V$ $C_L = 50pF$ , $R_L = 500\Omega$			$V_{CC} = +5.0V \pm 10\%$ $C_L = 50pF$ , $R_L = 500\Omega$		$V_{CC} = +5.0V \pm 10\%$ $C_L = 50pF$ , $R_L = 500\Omega$			
			MIN	TYP	MAX	MIN	MAX	MIN	MAX		
$t_{PLH}$ $t_{PHL}$	Propagation delay, A, B, C, D to YOUT	Waveform 1	2.5	4.5	7.5	2.0	8.5	2.0	8.5	ns	
$t_{PLH}$ $t_{PHL}$	Propagation delay, $\overline{BR}_n$ to $\overline{BG}_n$	Waveform 2	5.0	7.0	10.0	4.5	10.5	4.5	10.5	ns	
$t_{PLH}$ $t_{PHL}$	Propagation delay, EN to $\overline{BG}_n$	Waveform 2	3.0	5.0	8.0	2.5	8.5	2.5	8.5	ns	
$t_{PHL}$	Propagation delay, $\overline{BR}_a$ to $\overline{BG}_b$	Waveform 2	5.0	7.0	10.0	4.5	10.5	4.5	10.5	ns	

AC WAVEFORMS

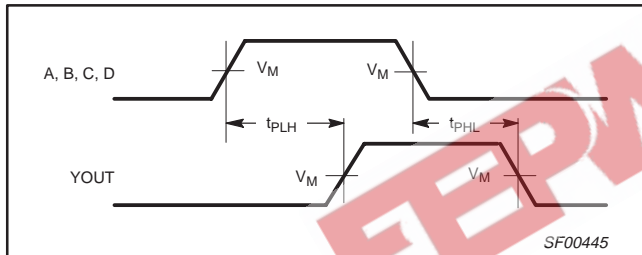

Waveform 1. Propagation delay for AND gate to output

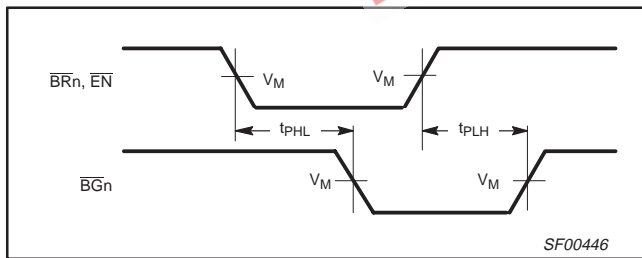

Waveform 2. Propagation delay for bus request or enable to bus grant output

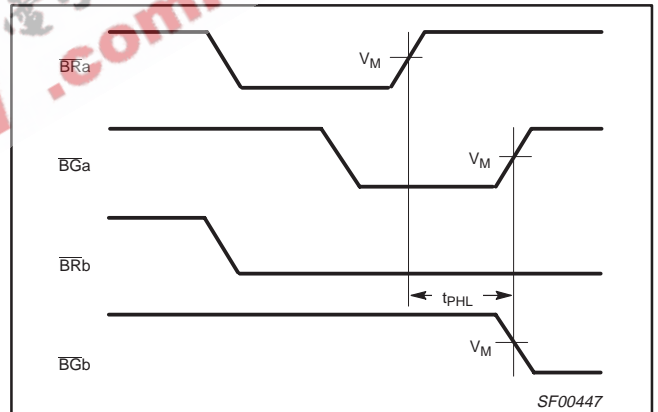

Waveform 3. Propagation delay for bus request to bus grant output

Notes to AC waveforms

1. For all waveforms,  $V_M = 1.5V$ .
2. a and b represents any of the bus requests or grants.  $\overline{BG}_a$  low-to-high transition and the  $\overline{BG}_b$  high-to-low transition occur simultaneously.

4-bit asynchronous bus arbiter

74F786

TEST CIRCUIT AND WAVEFORMS

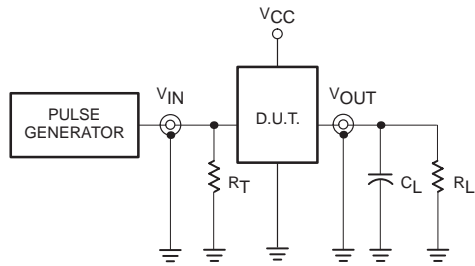

Test Circuit for Totem-Pole Outputs

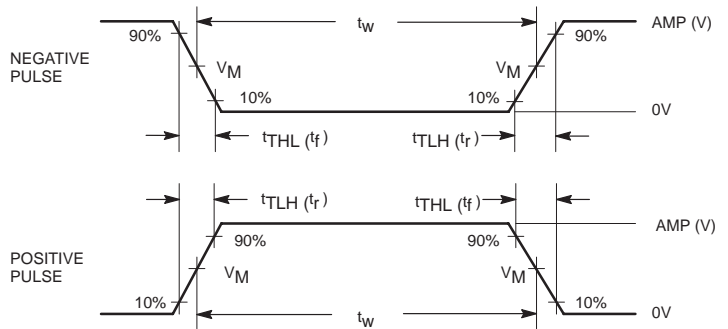

DEFINITIONS:

- $R_L$  = Load resistor; see AC ELECTRICAL CHARACTERISTICS for value.
- $C_L$  = Load capacitance includes jig and probe capacitance; see AC ELECTRICAL CHARACTERISTICS for value.
- $R_T$  = Termination resistance should be equal to  $Z_{OUT}$  of pulse generators.

Input Pulse Definition

family	INPUT PULSE REQUIREMENTS					
	amplitude	$V_M$	rep. rate	$t_w$	$t_{TLH}$	$t_{THL}$
74F	3.0V	1.5V	1MHz	500ns	2.5ns	2.5ns

SF00006



4-bit asynchronous bus arbiter

74F786

DIP16: plastic dual in-line package; 16 leads (300 mil)

SOT38-4

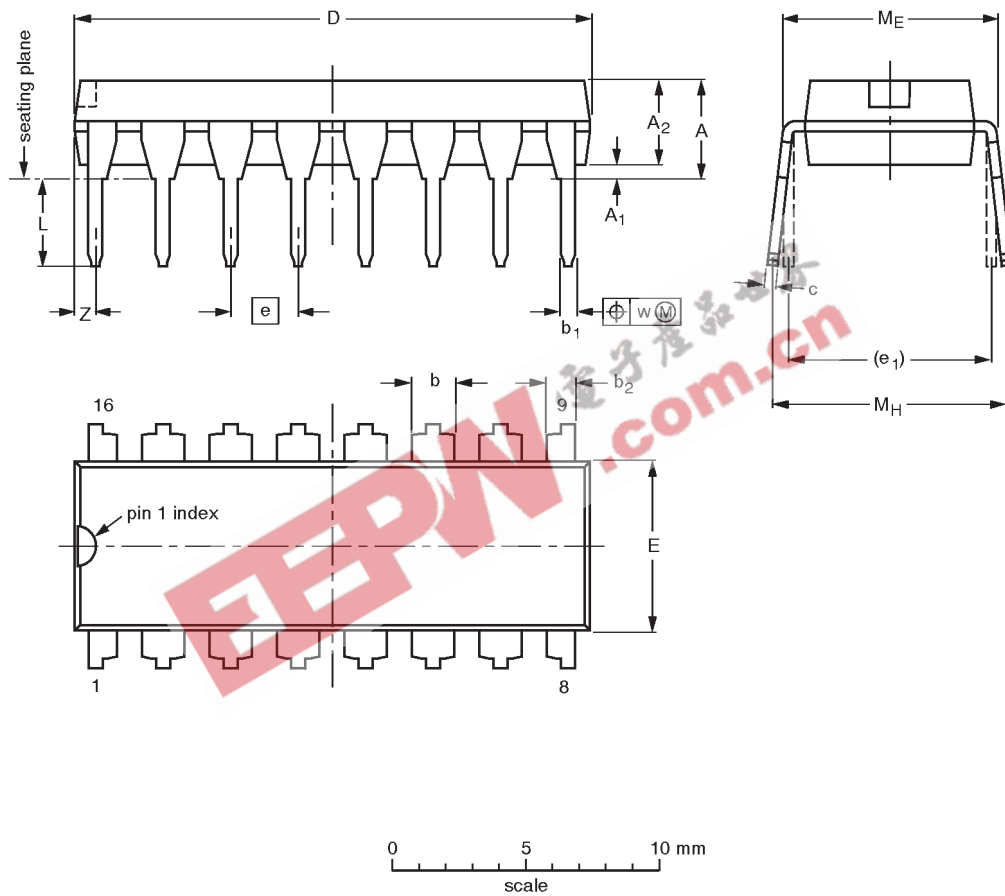

DIMENSIONS (inch dimensions are derived from the original mm dimensions)

UNIT	A max.	A <sub>1</sub> min.	A <sub>2</sub> max.	b	b <sub>1</sub>	b <sub>2</sub>	c	D <sup>(1)</sup>	E <sup>(1)</sup>	e	e <sub>1</sub>	L	M <sub>E</sub>	M <sub>H</sub>	w	z <sup>(1)</sup> max.
mm	4.2	0.51	3.2	1.73 1.30	0.53 0.38	1.25 0.85	0.36 0.23	19.50 18.55	6.48 6.20	2.54	7.62	3.60 3.05	8.25 7.80	10.0 8.3	0.254	0.76
inches	0.17	0.020	0.13	0.068 0.051	0.021 0.015	0.049 0.033	0.014 0.009	0.77 0.73	0.26 0.24	0.10	0.30	0.14 0.12	0.32 0.31	0.39 0.33	0.01	0.030

Note

1. Plastic or metal protrusions of 0.25 mm maximum per side are not included.

OUTLINE VERSION	REFERENCES				EUROPEAN PROJECTION	ISSUE DATE
	IEC	JEDEC	EIAJ			
SOT38-4						92-11-17 95-01-14

4-bit asynchronous bus arbiter

74F786

SO16: plastic small outline package; 16 leads; body width 3.9 mm

SOT109-1

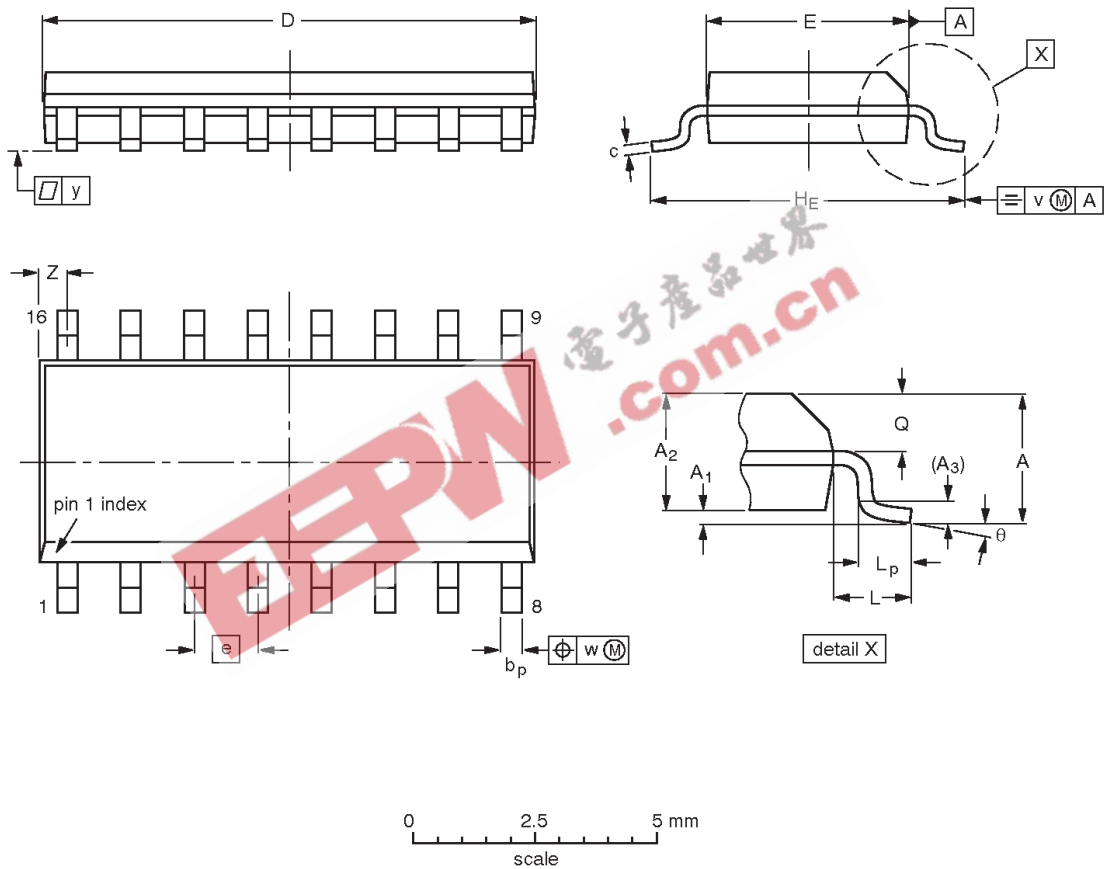

DIMENSIONS (inch dimensions are derived from the original mm dimensions)

UNIT	A max.	A <sub>1</sub>	A <sub>2</sub>	A <sub>3</sub>	b <sub>p</sub>	c	D <sup>(1)</sup>	E <sup>(1)</sup>	e	H <sub>E</sub>	L	L <sub>p</sub>	Q	v	w	y	Z <sup>(1)</sup>	$\theta$
mm	1.75	0.25 0.10	1.45 1.25	0.25	0.49 0.36	0.25 0.19	10.0 9.8	4.0 3.8	1.27	6.2 5.8	1.05	1.0 0.4	0.7 0.6	0.25	0.25	0.1	0.7 0.3	8° 0°
inches	0.069	0.010 0.004	0.057 0.049	0.01	0.019 0.014	0.0100 0.0075	0.39 0.38	0.16 0.15	0.050	0.244 0.228	0.041	0.039 0.016	0.028 0.020	0.01	0.01	0.004	0.028 0.012	

Note

1. Plastic or metal protrusions of 0.15 mm maximum per side are not included.

OUTLINE VERSION	REFERENCES				EUROPEAN PROJECTION	ISSUE DATE
	IEC	JEDEC	EIAJ			
SOT109-1	076E07S	MS-012AC				95-01-23 97-05-22

---

4-bit asynchronous bus arbiter

74F786

---

NOTES



## 4-bit asynchronous bus arbiter

74F786

## Data sheet status

Data sheet status	Product status	Definition [1]
Objective specification	Development	This data sheet contains the design target or goal specifications for product development. Specification may change in any manner without notice.
Preliminary specification	Qualification	This data sheet contains preliminary data, and supplementary data will be published at a later date. Philips Semiconductors reserves the right to make changes at any time without notice in order to improve design and supply the best possible product.
Product specification	Production	This data sheet contains final specifications. Philips Semiconductors reserves the right to make changes at any time without notice in order to improve design and supply the best possible product.

[1] Please consult the most recently issued datasheet before initiating or completing a design.

## Definitions

**Short-form specification** — The data in a short-form specification is extracted from a full data sheet with the same type number and title. For detailed information see the relevant data sheet or data handbook.

**Limiting values definition** — Limiting values given are in accordance with the Absolute Maximum Rating System (IEC 134). Stress above one or more of the limiting values may cause permanent damage to the device. These are stress ratings only and operation of the device at these or at any other conditions above those given in the Characteristics sections of the specification is not implied. Exposure to limiting values for extended periods may affect device reliability.

**Application information** — Applications that are described herein for any of these products are for illustrative purposes only. Philips Semiconductors make no representation or warranty that such applications will be suitable for the specified use without further testing or modification.

## Disclaimers

**Life support** — These products are not designed for use in life support appliances, devices or systems where malfunction of these products can reasonably be expected to result in personal injury. Philips Semiconductors customers using or selling these products for use in such applications do so at their own risk and agree to fully indemnify Philips Semiconductors for any damages resulting from such application.

**Right to make changes** — Philips Semiconductors reserves the right to make changes, without notice, in the products, including circuits, standard cells, and/or software, described or contained herein in order to improve design and/or performance. Philips Semiconductors assumes no responsibility or liability for the use of any of these products, conveys no license or title under any patent, copyright, or mask work right to these products, and makes no representations or warranties that these products are free from patent, copyright, or mask work right infringement, unless otherwise specified.

Philips Semiconductors  
811 East Arques Avenue  
P.O. Box 3409  
Sunnyvale, California 94088-3409  
Telephone 800-234-7381

© Copyright Philips Electronics North America Corporation 1998  
All rights reserved. Printed in U.S.A.

print code

Date of release: 10-98

Document order number:

9397-750-05181

*Let's make things better.*