

DATA SHEET

For a complete data sheet, please also download:

- The IC06 74HC/HCT/HCU/HCMOS Logic Family Specifications
- The IC06 74HC/HCT/HCU/HCMOS Logic Package Information
- The IC06 74HC/HCT/HCU/HCMOS Logic Package Outlines

EEPW 电子产品世界
.com.cn

74HC/HCT147 10-to-4 line priority encoder

Product specification
File under Integrated Circuits, IC06

December 1990

10-to-4 line priority encoder

74HC/HCT147

FEATURES

- Encodes 10-line decimal to 4-line BCD
- Useful for 10-position switch encoding
- Used in code converters and generators
- Output capability: standard
- I_{CC} category: MSI

GENERAL DESCRIPTION

The 74HC/HCT147 are high-speed Si-gate CMOS devices and are pin compatible with low power Schottky TTL (LSTTL). They are specified in compliance with JEDEC standard no. 7A.

The 74HC/HCT147 9-input priority encoders accept data from nine active LOW inputs (\bar{A}_0 to \bar{A}_8) and provide a binary representation on the four active LOW outputs (\bar{Y}_0 to \bar{Y}_3). A priority is assigned to each input so that when two or more inputs are simultaneously active, the input with the highest priority is represented on the output, with input line \bar{A}_8 having the highest priority.

The devices provide the 10-line to 4-line priority encoding function by use of the implied decimal "zero". The "zero" is encoded when all nine data inputs are HIGH, forcing all four outputs HIGH.

QUICK REFERENCE DATA

GND = 0 V; $T_{amb} = 25\text{ }^\circ\text{C}$; $t_r = t_f = 6\text{ ns}$

SYMBOL	PARAMETER	CONDITIONS	TYPICAL		UNIT
			HC	HCT	
t_{PHL}/t_{PLH}	propagation delay \bar{A}_n to \bar{Y}_n	$C_L = 15\text{ pF}$; $V_{CC} = 5\text{ V}$	15	17	ns
C_I	input capacitance		3.5	3.5	pF
C_{PD}	power dissipation capacitance per package	notes 1 and 2	30	33	pF

Notes

1. C_{PD} is used to determine the dynamic power dissipation (P_D in μW):

$$P_D = C_{PD} \times V_{CC}^2 \times f_i + \sum (C_L \times V_{CC}^2 \times f_o) \text{ where:}$$

f_i = input frequency in MHz

f_o = output frequency in MHz

$\sum (C_L \times V_{CC}^2 \times f_o)$ = sum of outputs

C_L = output load capacitance in pF

V_{CC} = supply voltage in V

2. For HC the condition is $V_I = \text{GND to } V_{CC}$
For HCT the condition is $V_I = \text{GND to } V_{CC} - 1.5\text{ V}$

ORDERING INFORMATION

See "74HC/HCT/HCU/HCMOS Logic Package Information".

10-to-4 line priority encoder

74HC/HCT147

PIN DESCRIPTION

PIN NO.	SYMBOL	NAME AND FUNCTION
8	GND	ground (0 V)
9, 7, 6, 14	\bar{Y}_0 to \bar{Y}_3	BCD address outputs (active LOW)
11, 12, 13, 1, 2, 3, 4, 5, 10	\bar{A}_0 to \bar{A}_8	decimal data inputs (active LOW)
15	n.c.	not connected
16	V _{CC}	positive supply voltage

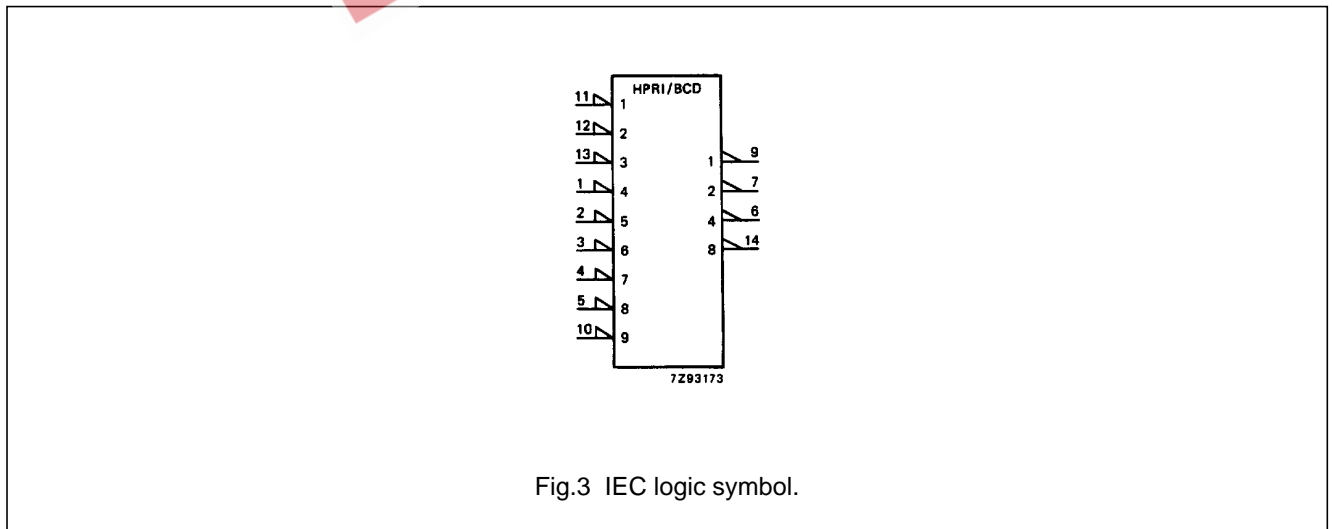
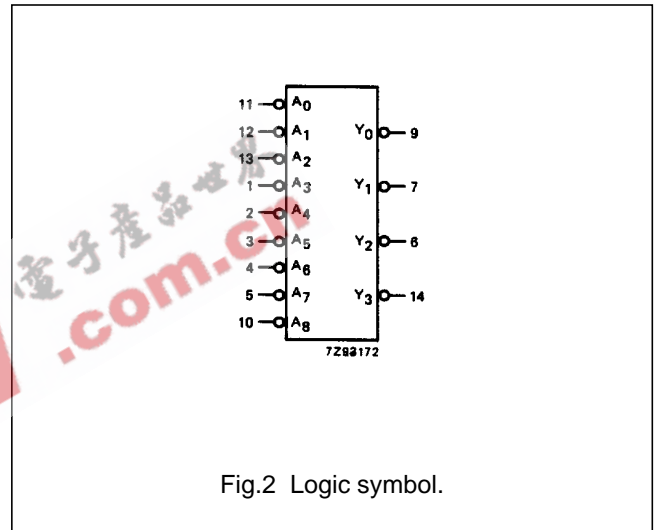
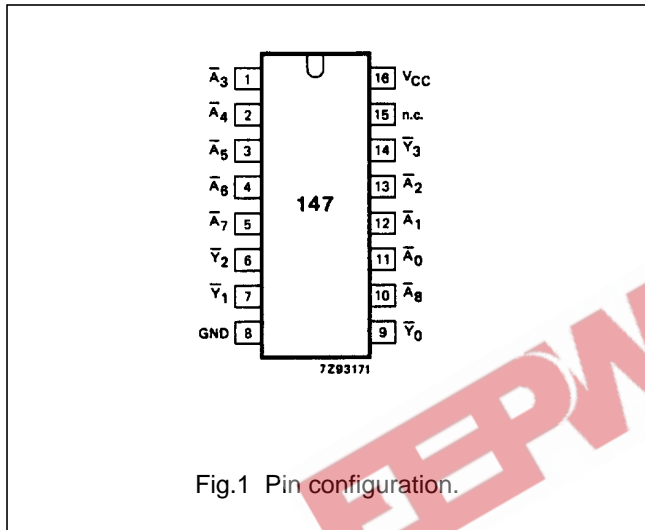

10-to-4 line priority encoder

74HC/HCT147

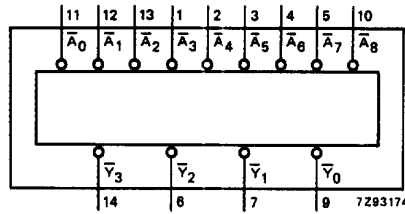

Fig.4 Functional diagram.

FUNCTION TABLE

INPUTS									OUTPUTS			
\bar{A}_0	\bar{A}_1	\bar{A}_2	\bar{A}_3	\bar{A}_4	\bar{A}_5	\bar{A}_6	\bar{A}_7	\bar{A}_8	\bar{Y}_3	\bar{Y}_2	\bar{Y}_1	\bar{Y}_0
H	H	H	H	H	H	H	H	H	H	H	H	H
X	X	X	X	X	X	X	X	L	L	H	H	L
X	X	X	X	X	X	X	L	H	L	H	H	H
X	X	X	X	X	X	L	H	H	H	L	L	L
X	X	X	X	X	L	H	H	H	H	L	L	H
X	X	X	L	H	H	H	H	H	H	L	H	L
X	X	X	L	H	H	H	H	H	H	L	H	H
X	X	L	H	H	H	H	H	H	H	H	L	L
X	L	H	H	H	H	H	H	H	H	H	L	H
L	H	H	H	H	H	H	H	H	H	H	H	L

Notes

1. H = HIGH voltage level
 L = LOW voltage level
 X = don't care

10-to-4 line priority encoder

74HC/HCT147

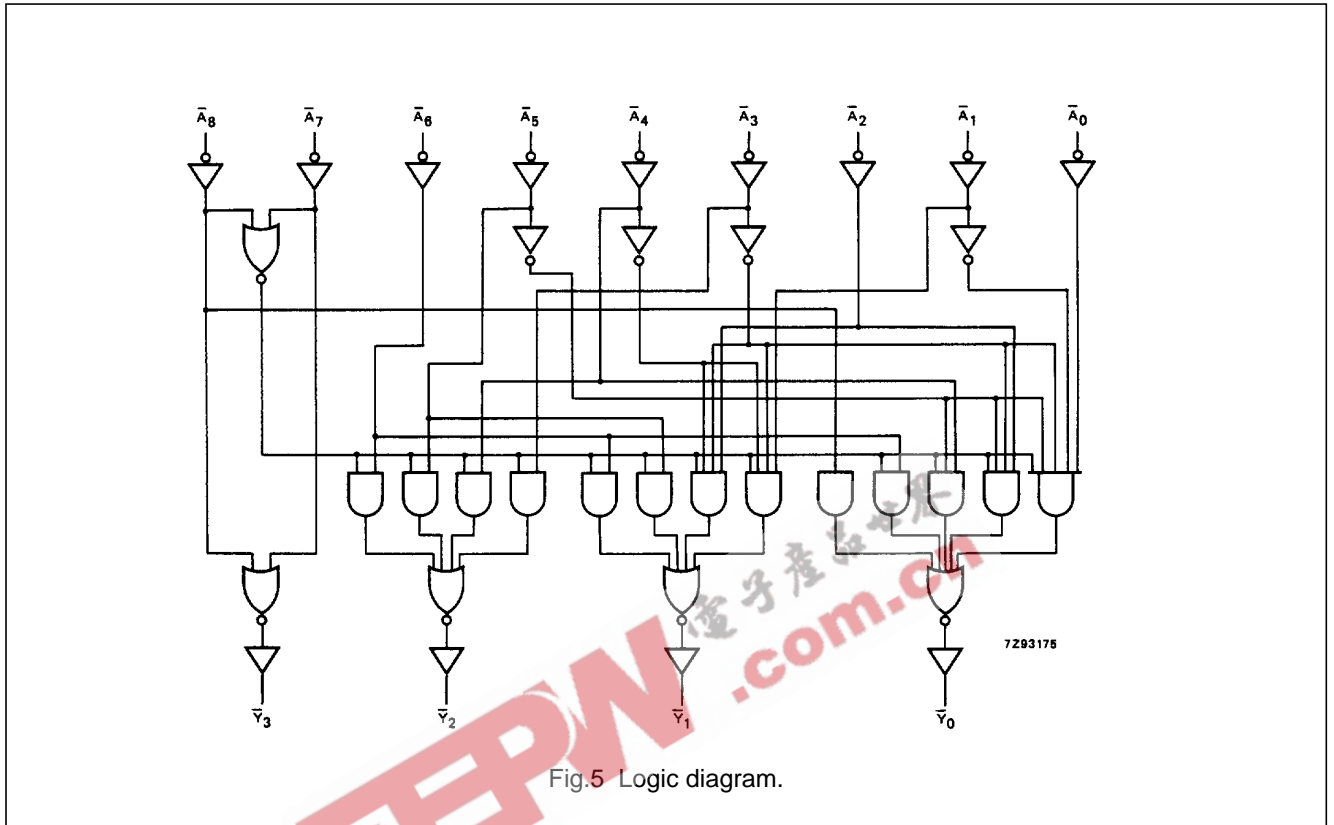

Fig.5 Logic diagram.

10-to-4 line priority encoder

74HC/HCT147

DC CHARACTERISTICS FOR 74HC

For the DC characteristics see *"74HC/HCT/HCU/HCMOS Logic Family Specifications"*.

Output capability: standard

I_{CC} category: MSI

AC CHARACTERISTICS FOR 74HC

GND = 0 V; t_r = t_f = 6 ns; C_L = 50 pF

SYMBOL	PARAMETER	T _{amb} (°C)						UNIT	TEST CONDITIONS		
		74HC							V _{CC} (V)	WAVEFORMS	
		+25			-40 to +85		-40 to +125				
		min.	typ.	max.	min.	max.	min.				max.
t _{PHL} / t _{PLH}	propagation delay \bar{A}_n to \bar{Y}_n		50 18 14	160 32 27		200 40 34		240 48 41	ns	2.0 4.5 6.0	Fig.6
t _{THL} / t _{TLH}	output transition time		19 7 6	75 15 6		95 19 16		110 22 19	ns	2.0 4.5 6.0	Fig.6

10-to-4 line priority encoder

74HC/HCT147

DC CHARACTERISTICS FOR 74HCT

For the DC characteristics see *"74HC/HCT/HCU/HCMOS Logic Family Specifications"*.

Output capability: standard

I_{CC} category: MSI

Note to HCT types

The value of additional quiescent supply current (ΔI_{CC}) for a unit load of 1 is given in the family specifications. To determine ΔI_{CC} per input, multiply this value by the unit load coefficient shown in the table below.

INPUT	UNIT LOAD COEFFICIENT
$\bar{A}_3, \bar{A}_4, \bar{A}_7, \bar{A}_8$	1.50
$\bar{A}_5, \bar{A}_6, \bar{A}_0, \bar{A}_1, \bar{A}_2$	1.10

AC CHARACTERISTICS FOR 74HCT

GND = 0 V; $t_r = t_f = 6$ ns; $C_L = 50$ pF

SYMBOL	PARAMETER	T _{amb} (°C)						UNIT	TEST CONDITIONS		
		74HCT							V _{CC} (V)	WAVEFORMS	
		+25			-40 to +85		-40 to +125				
		min.	typ.	max.	min.	max.	min.				max.
t _{PHL} /t _{PLH}	propagation delay \bar{A}_n to \bar{Y}_n		20	35		44		53	ns	4.5	Fig.6
t _{THL} /t _{TLH}	output transition time		7	15		19		22	ns	4.5	Fig.6

AC WAVEFORMS

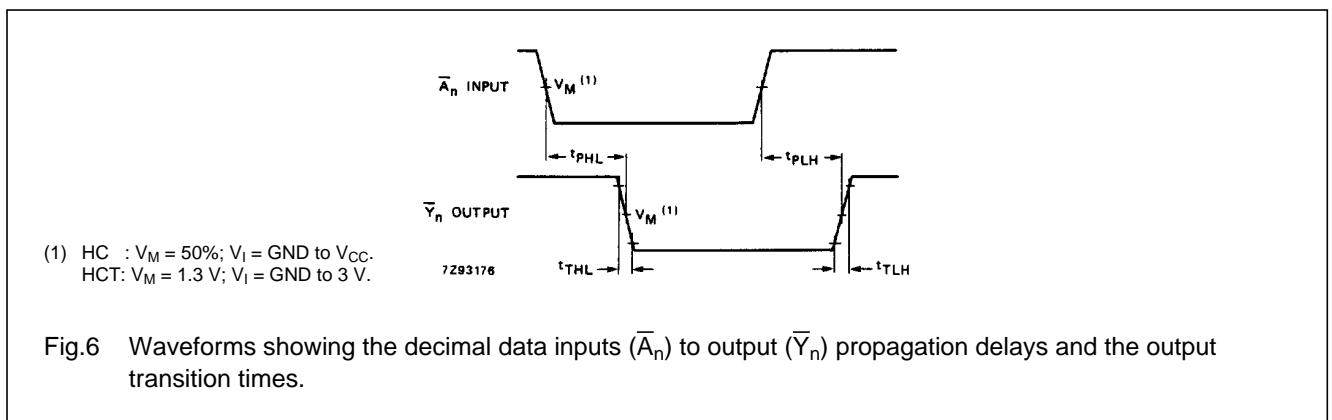

PACKAGE OUTLINES

See *"74HC/HCT/HCU/HCMOS Logic Package Outlines"*.