

# DATA SHEET

For a complete data sheet, please also download:

- The IC06 74HC/HCT/HCU/HCMOS Logic Family Specifications
- The IC06 74HC/HCT/HCU/HCMOS Logic Package Information
- The IC06 74HC/HCT/HCU/HCMOS Logic Package Outlines

EEPW 电子产品世界  
.com.cn

## 74HC/HCT163

Presettable synchronous 4-bit  
binary counter; synchronous reset

Product specification  
File under Integrated Circuits, IC06

December 1990

# Presettable synchronous 4-bit binary counter; synchronous reset

## 74HC/HCT163

### FEATURES

- Synchronous counting and loading
- Two count enable inputs for n-bit cascading
- Positive-edge triggered clock
- Synchronous reset
- Output capability: standard
- I<sub>CC</sub> category: MSI

### GENERAL DESCRIPTION

The 74HC/HCT163 are high-speed Si-gate CMOS devices and are pin compatible with low power Schottky TTL (LSTTL). They are specified in compliance with JEDEC standard no. 7A.

The 74HC/HCT163 are synchronous presettable binary counters which feature an internal look-ahead carry and can be used for high-speed counting.

Synchronous operation is provided by having all flip-flops clocked simultaneously on the positive-going edge of the clock (CP).

The outputs (Q<sub>0</sub> to Q<sub>3</sub>) of the counters may be preset to a HIGH or LOW level. A LOW level at the parallel enable input (PE) disables the counting action and causes the data at the data inputs (D<sub>0</sub> to D<sub>3</sub>) to be loaded into the counter on the positive-going edge of the clock (providing that the set-up and hold time requirements for PE are met).

Preset takes place regardless of the levels at count enable inputs (CEP and CET).

For the "163" the clear function is synchronous.

A LOW level at the master reset input ( $\overline{MR}$ ) sets all four outputs of the flip-flops (Q<sub>0</sub> to Q<sub>3</sub>) to LOW level after the next positive-going transition on the clock (CP) input (provided that the set-up and hold time requirements for  $\overline{MR}$  are met). This action occurs regardless of the levels at  $\overline{PE}$ , CET and CEP inputs.

This synchronous reset feature enables the designer to modify the maximum count with only one external NAND gate.

The look-ahead carry simplifies serial cascading of the counters. Both count enable inputs (CEP and CET) must be HIGH to count. The CET input is fed forward to enable the terminal count output (TC). The TC output thus enabled will produce a HIGH output pulse of a duration approximately equal to a HIGH level output of Q<sub>0</sub>. This pulse can be used to enable the next cascaded stage.

The maximum clock frequency for the cascaded counters is determined by the CP to TC propagation delay and CEP to CP set-up time, according to the following formula:

$$f_{max} = \frac{1}{t_{P(max)}(CP\ to\ TC) + t_{SU}(CEP\ to\ CP)}$$

### QUICK REFERENCE DATA

GND = 0 V; T<sub>amb</sub> = 25 °C; t<sub>r</sub> = t<sub>f</sub> = 6 ns

SYMBOL	PARAMETER	CONDITIONS	TYPICAL		UNIT
			HC	HCT	
t <sub>PHL</sub> / t <sub>PLH</sub>	propagation delay CP to Q <sub>n</sub> CP to TC CET to TC	C <sub>L</sub> = 15 pF; V <sub>CC</sub> = 5 V	17	20	ns
			21	25	ns
			11	14	ns
f <sub>max</sub>	maximum clock frequency		51	50	MHz
C <sub>I</sub>	input capacitance		3.5	3.5	pF
C <sub>PD</sub>	power dissipation capacitance per package	notes 1 and 2	33	35	pF

### Notes

1. C<sub>PD</sub> is used to determine the dynamic power dissipation (P<sub>D</sub> in μW):

$$P_D = C_{PD} \times V_{CC}^2 \times f_i + \sum (C_L \times V_{CC}^2 \times f_o)$$

where:

f<sub>i</sub> = input frequency in MHz

f<sub>o</sub> = output frequency in MHz

∑ (C<sub>L</sub> × V<sub>CC</sub><sup>2</sup> × f<sub>o</sub>) = sum of outputs

C<sub>L</sub> = output load capacitance in pF

V<sub>CC</sub> = supply voltage in V

2. For HC the condition is

$$V_I = GND\ to\ V_{CC}$$

For HCT the condition is

$$V_I = GND\ to\ V_{CC} - 1.5\ V$$

Presettable synchronous 4-bit binary counter; synchronous reset

74HC/HCT163

ORDERING INFORMATION

See "74HC/HCT/HCU/HCMOS Logic Package Information".

PIN DESCRIPTION

PIN NO.	SYMBOL	NAME AND FUNCTION
1	$\overline{MR}$	synchronous master reset (active LOW)
2	CP	clock input (LOW-to-HIGH, edge-triggered)
3, 4, 5, 6	D <sub>0</sub> to D <sub>3</sub>	data inputs
7	CEP	count enable input
8	GND	ground (0 V)
9	$\overline{PE}$	parallel enable input (active LOW)
10	CET	count enable carry input
14, 13, 12, 11	Q <sub>0</sub> to Q <sub>3</sub>	flip-flop outputs
15	TC	terminal count output
16	V <sub>CC</sub>	positive supply voltage

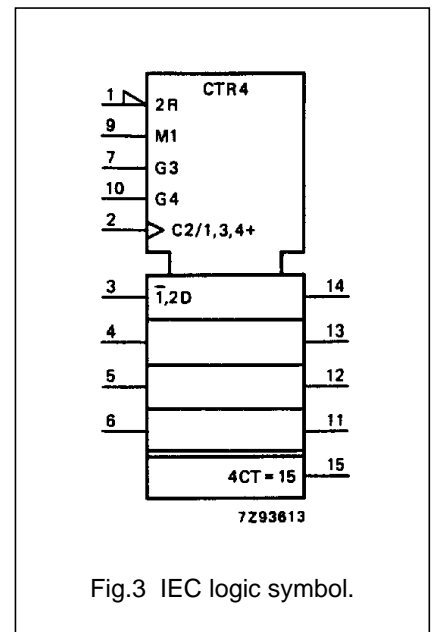
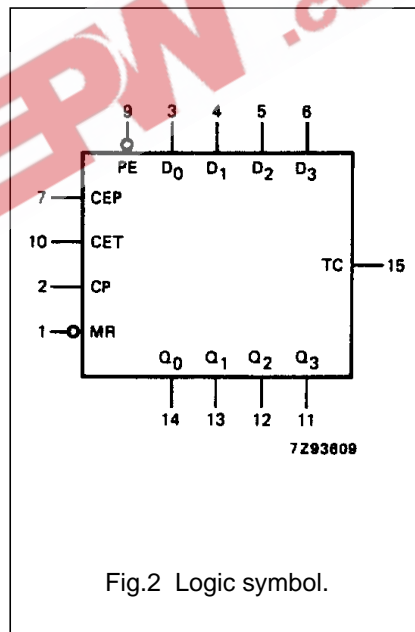
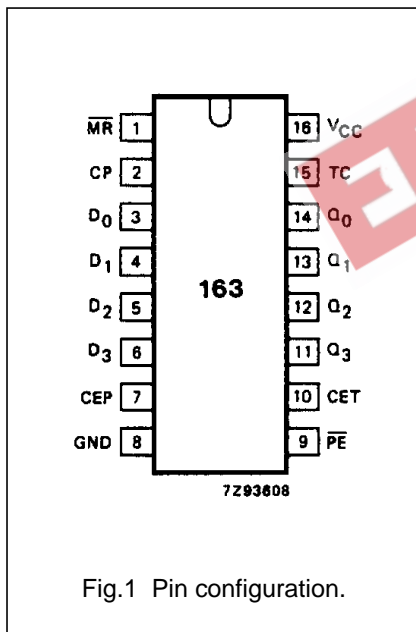

Presettable synchronous 4-bit binary counter; synchronous reset

74HC/HCT163

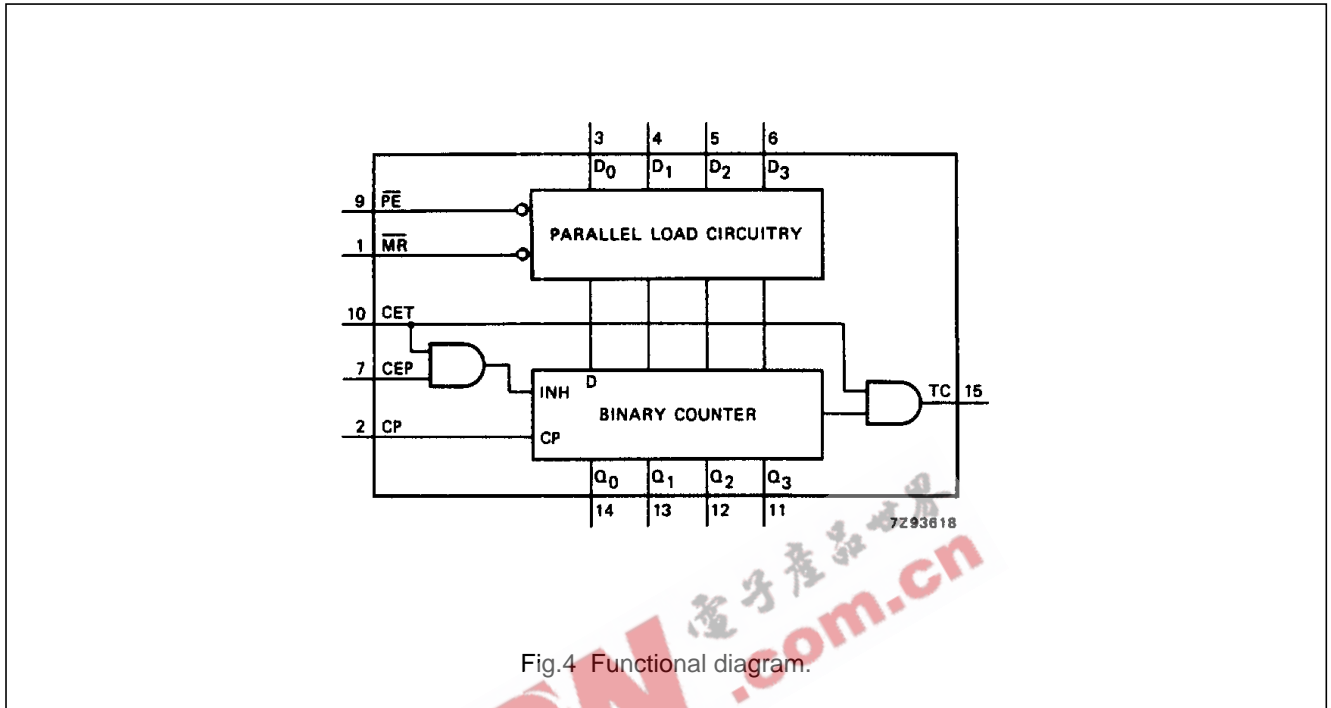

Fig.4 Functional diagram.

FUNCTION TABLE

OPERATING MODE	INPUTS						OUTPUTS	
	$\overline{MR}$	CP	CEP	CET	$\overline{PE}$	$D_n$	$Q_n$	TC
reset (clear)	l	$\uparrow$	X	X	X	X	L	L
parallel load	h	$\uparrow$	X	X	l	l	L	L
	h	$\uparrow$	X	X	l	h	H	(1)
count	h	$\uparrow$	h	h	h	X	count	(1)
hold (do nothing)	h	X	l	X	h	X	$q_n$	(1)
	h	X	X	l	h	X	$q_n$	L

Notes

- The TC output is HIGH when CET is HIGH and the counter is at terminal count (HHHH).  
 H = HIGH voltage level  
 h = HIGH voltage level one set-up time prior to the LOW-to-HIGH CP transition  
 L = LOW voltage level  
 l = LOW voltage level one set-up time prior to the LOW-to-HIGH CP transition  
 q = lower case letters indicate the state of the referenced output one set-up time prior to the LOW-to-HIGH CP transition  
 X = don't care  
 $\uparrow$  = LOW-to-HIGH CP transition

# Presetable synchronous 4-bit binary counter; synchronous reset

74HC/HCT163

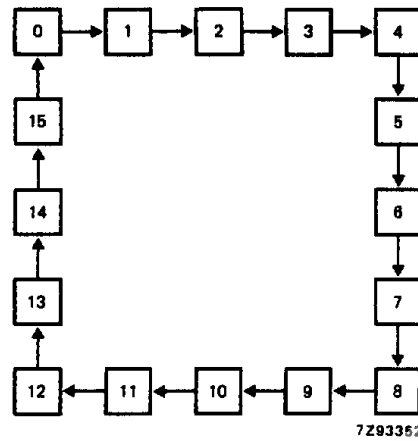

Fig.5 State diagram.

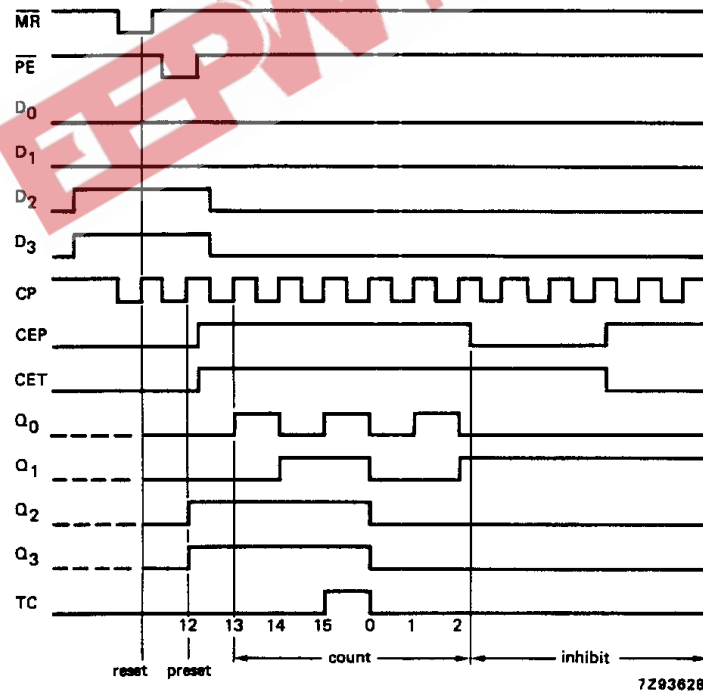
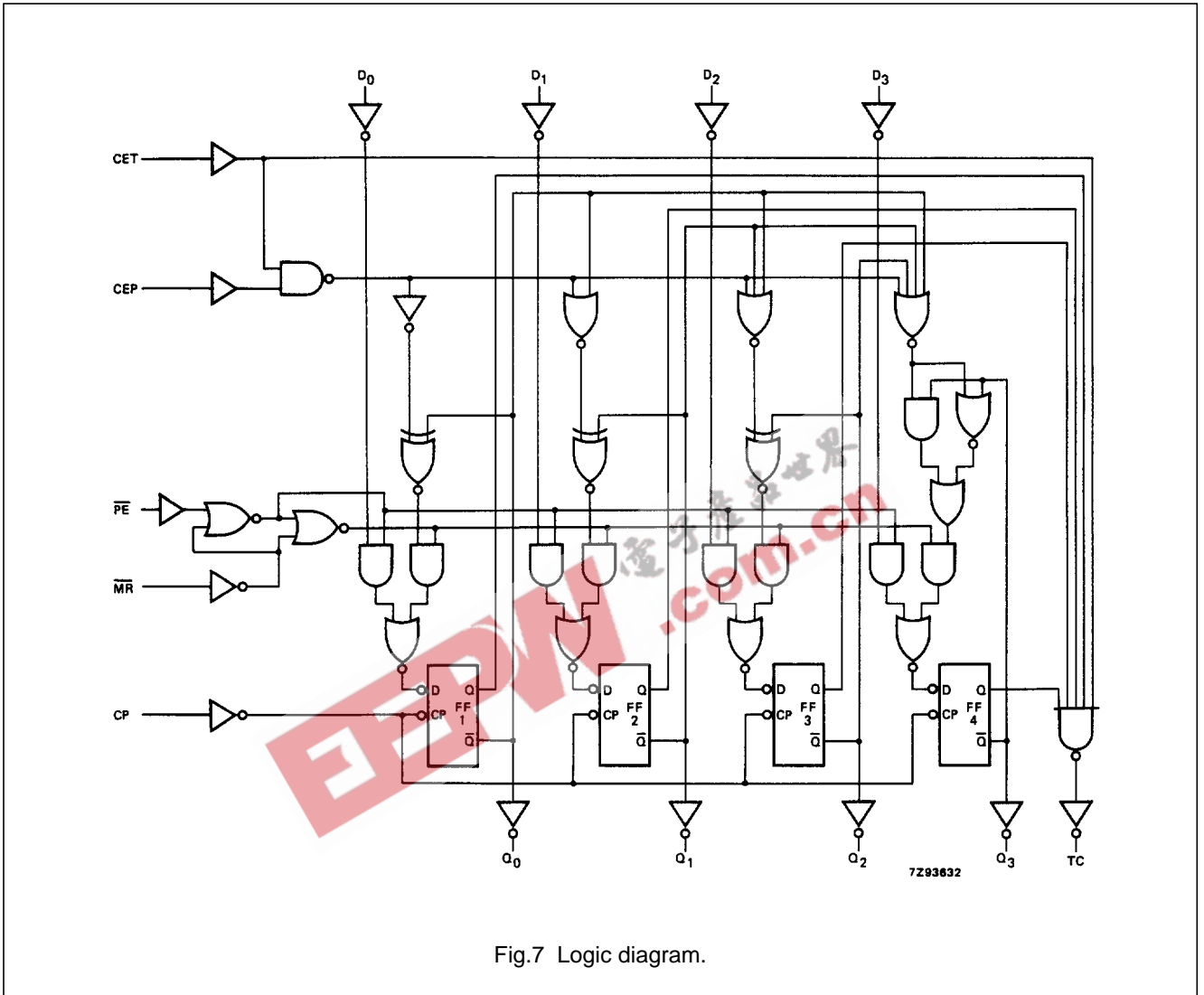

Fig.6 Typical timing sequence: reset outputs to zero; preset to binary twelve; count to thirteen, fourteen, fifteen, zero, one and two; inhibit.

Presetable synchronous 4-bit binary counter; synchronous reset

74HC/HCT163



# Presetable synchronous 4-bit binary counter; synchronous reset

74HC/HCT163

## DC CHARACTERISTICS FOR 74HC

For the DC characteristics see "74HC/HCT/HCU/HCMOS Logic Family Specifications".

Output capability: standard

I<sub>CC</sub> category: MSI

## AC CHARACTERISTICS FOR 74HC

GND = 0 V; t<sub>r</sub> = t<sub>f</sub> = 6 ns; C<sub>L</sub> = 50 pF

SYMBOL	PARAMETER	T <sub>amb</sub> (°C)						UNIT	TEST CONDITIONS		
		74HC							V <sub>CC</sub> (V)	WAVEFORMS	
		+25			-40 to +85		-40 to +125				
		min.	typ.	max.	min.	max.	min.				max.
t <sub>PHL</sub> / t <sub>PLH</sub>	propagation delay CP to Q <sub>n</sub>		55 20 16	185 37 31		230 46 39		280 56 48	ns	2.0 4.5 6.0	Fig.8
t <sub>PHL</sub> / t <sub>PLH</sub>	propagation delay CP to TC		69 25 20	215 43 37		270 54 46		320 65 55	ns	2.0 4.5 6.0	Fig.8
t <sub>PHL</sub> / t <sub>PLH</sub>	propagation delay CET to TC		36 13 10	120 24 20		150 30 26		180 36 31	ns	2.0 4.5 6.0	Fig.9
t <sub>THL</sub> / t <sub>TLH</sub>	output transition time		19 7 6	75 15 13		95 19 16		110 22 19	ns	2.0 4.5 6.0	Figs 8 and 9
t <sub>W</sub>	clock pulse width HIGH or LOW	80 16 14	17 6 5		100 20 17		120 24 20		ns	2.0 4.5 6.0	Fig.8
t <sub>su</sub>	set-up time MR, D <sub>n</sub> to CP	80 16 14	17 6 5		100 20 17		120 24 20		ns	2.0 4.5 6.0	Figs 10 and 11
t <sub>su</sub>	set-up time PE to CP	80 16 14	22 8 6		100 20 17		120 24 20		ns	2.0 4.5 6.0	Fig.10
t <sub>su</sub>	set-up time CEP, CET to CP	175 35 30	58 21 17		220 44 37		265 53 45		ns	2.0 4.5 6.0	Fig.12
t <sub>h</sub>	hold time D <sub>n</sub> , PE, CEP, CET, MR to CP	0 0 0	-14 -5 -4		0 0 0		0 0 0		ns	2.0 4.5 6.0	Figs 10, 11 and 12
f <sub>max</sub>	maximum clock pulse frequency	5 27 32	15 46 55		4 22 26		4 18 21		MHz	2.0 4.5 6.0	Fig.8

---

**Presettable synchronous 4-bit binary counter; synchronous reset**

---

**74HC/HCT163****DC CHARACTERISTICS FOR 74HCT**

For the DC characteristics see *"74HC/HCT/HCU/HCMOS Logic Family Specifications"*.

Output capability: standard

I<sub>CC</sub> category: MSI

**Note to HCT types**

The value of additional quiescent supply current ( $\Delta I_{CC}$ ) for a unit load of 1 is given in the family specifications. To determine  $\Delta I_{CC}$  per input, multiply this value by the unit load coefficient shown in the table below.

INPUT	UNIT LOAD COEFFICIENT
$\overline{MR}$	0.95
CP	1.10
CEP	0.25
D <sub>n</sub>	0.25
CET	0.75
$\overline{PE}$	0.30

EEPW.com.cn 电子产品世界



# Presettable synchronous 4-bit binary counter; synchronous reset

74HC/HCT163

**AC CHARACTERISTICS FOR 74HCT**GND = 0 V;  $t_r = t_f = 6$  ns;  $C_L = 50$  pF

SYMBOL	PARAMETER	$T_{amb}$ (°C)						UNIT	TEST CONDITIONS		
		74HCT							$V_{CC}$ (V)	WAVEFORMS	
		+25			-40 to +85		-40 to +125				
		min.	typ.	max.	min.	max.	min.				max.
$t_{PHL}/t_{PLH}$	propagation delay CP to $Q_n$		23	39		49		59	ns	4.5	Fig.8
$t_{PHL}/t_{PLH}$	propagation delay CP to TC		29	49		61		74	ns	4.5	Fig.8
$t_{PHL}/t_{PLH}$	propagation delay CET to TC		17	32		44		48	ns	4.5	Fig.9
$t_{THL}/t_{TLH}$	output transition time		7	15		19		22	ns	4.5	Figs 8 and 9
$t_W$	clock pulse width HIGH or LOW	20	6		25		30		ns	4.5	Fig.8
$t_{su}$	set-up time $\overline{MR}$ , $D_n$ to CP	20	9		25		30		ns	4.5	Figs 10 and 11
$t_{su}$	set-up time $\overline{PE}$ to CP	20	11		25		30		ns	4.5	Fig.10
$t_{su}$	set-up time CEP, CET to CP	40	24		50		60		ns	4.5	Fig.12
$t_h$	hold time $D_n$ , $\overline{PE}$ , CEP, CET, MR to CP	0	-5		0		0		ns	4.5	Figs 10, 11 and 12
$f_{max}$	maximum clock pulse frequency	26	45		21		17		MHz	4.5	Fig.8

Presettable synchronous 4-bit binary counter; synchronous reset

74HC/HCT163

AC WAVEFORMS

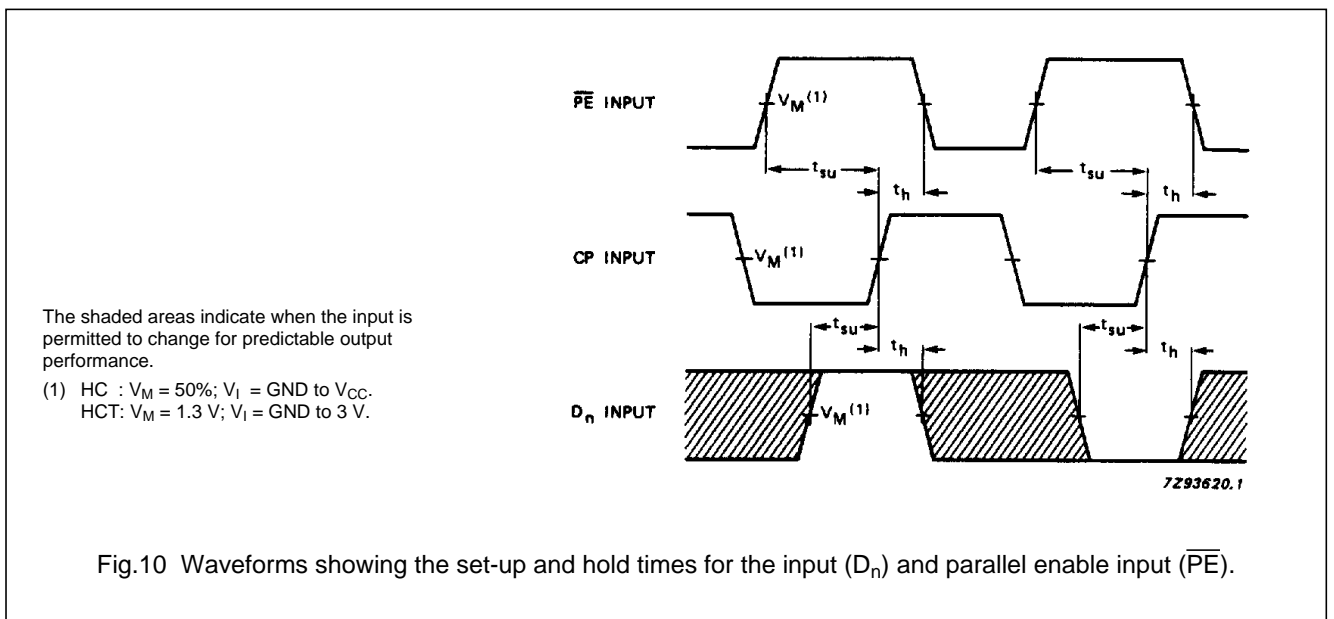
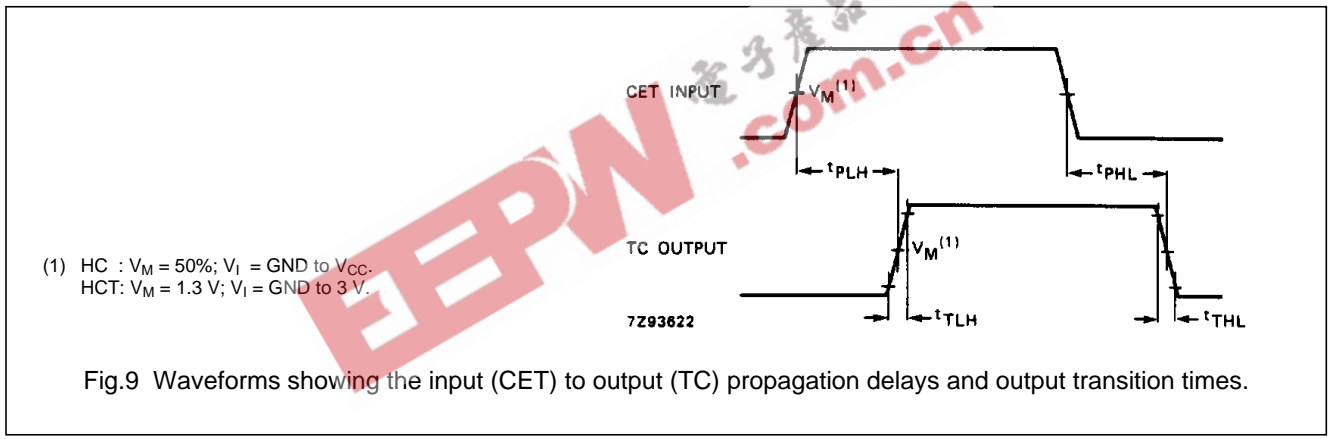
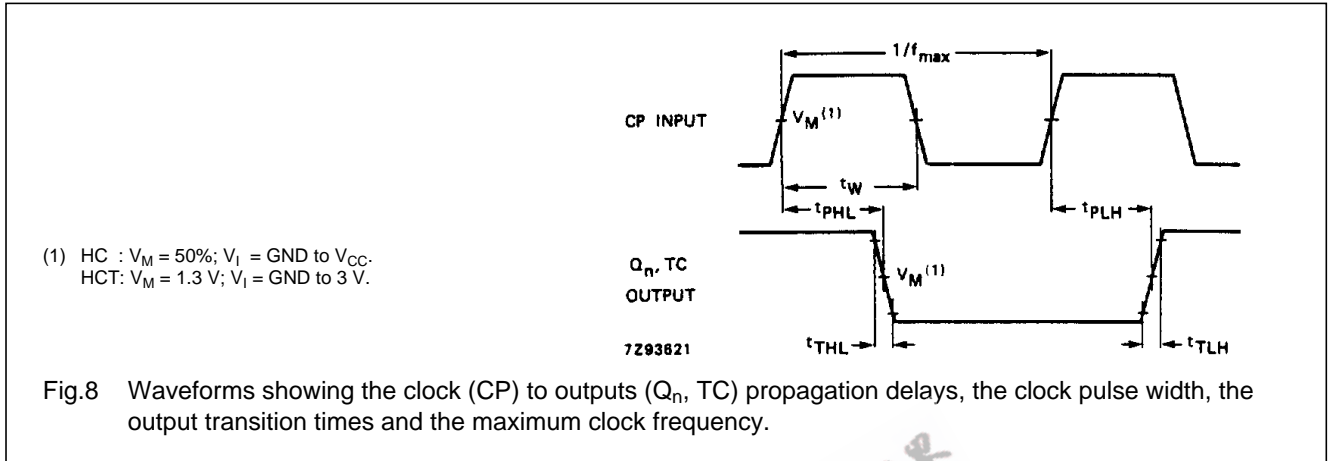

Pre-settable synchronous 4-bit binary counter; synchronous reset

74HC/HCT163

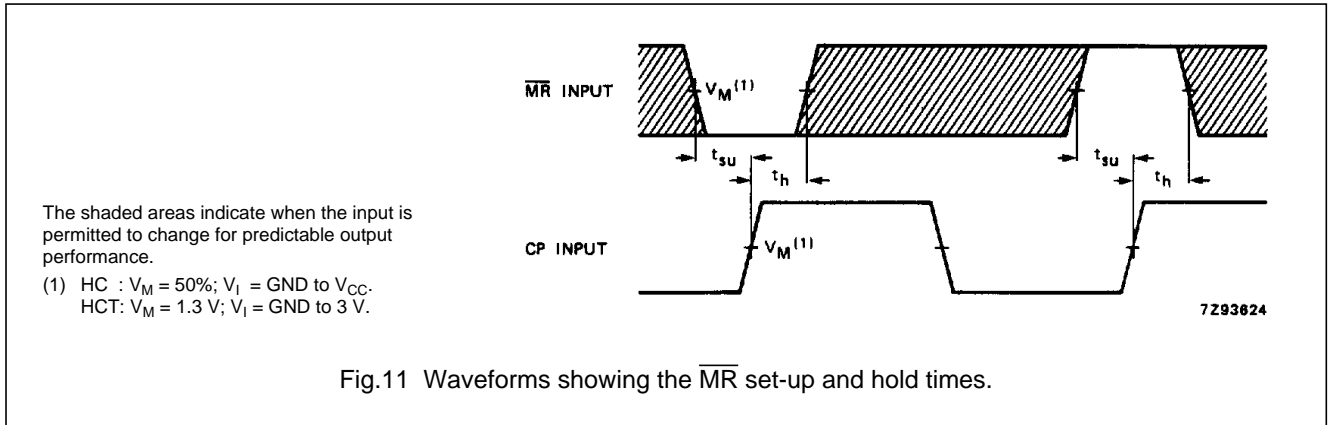

Fig.11 Waveforms showing the  $\overline{\text{MR}}$  set-up and hold times.

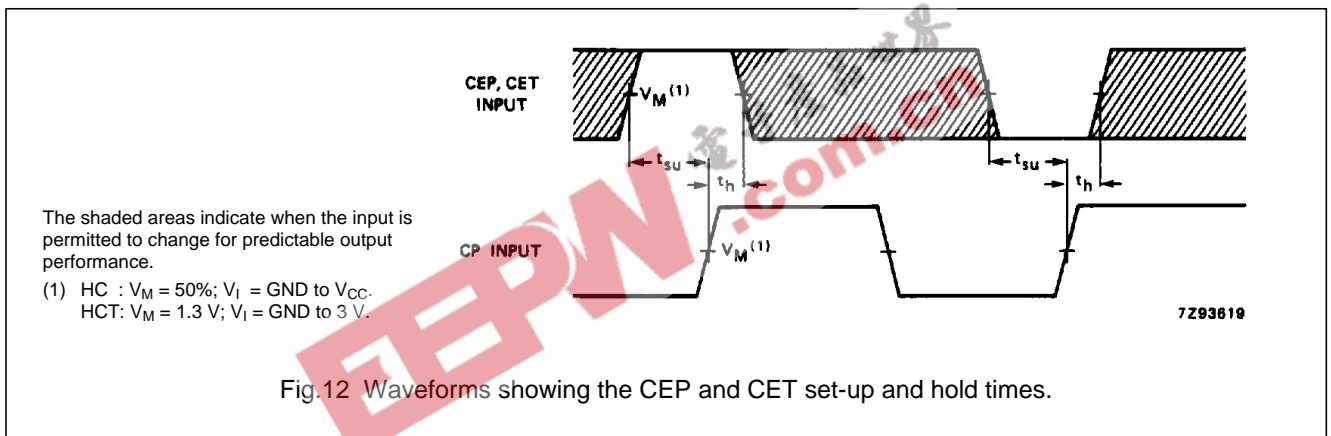

Fig.12 Waveforms showing the CEP and CET set-up and hold times.

APPLICATION INFORMATION

The HC/HCT163 facilitate designing counters of any modulus with minimal external logic. The output is glitch-free due to the synchronous reset.

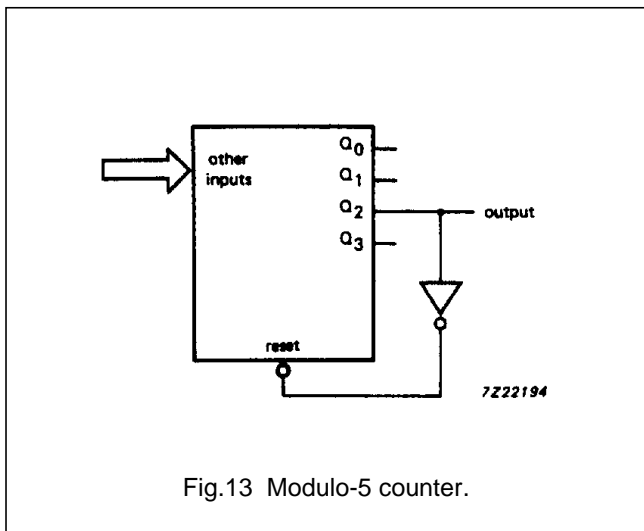

Fig.13 Modulo-5 counter.

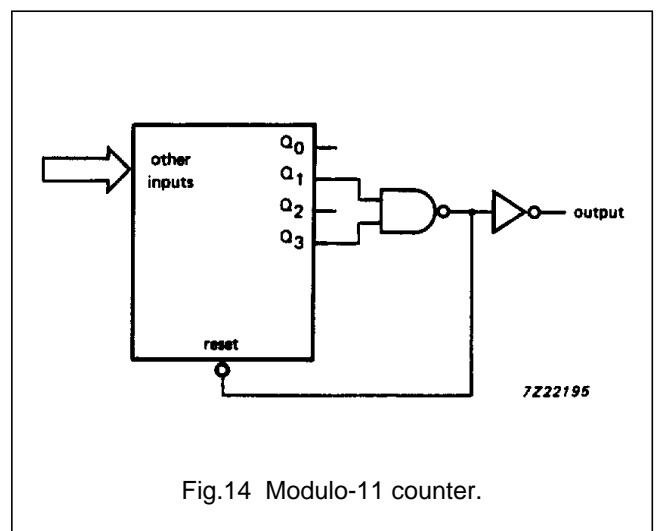

Fig.14 Modulo-11 counter.

PACKAGE OUTLINES

See "74HC/HCT/HCU/HCMOS Logic Package Outlines".