

DATA SHEET

EEPW 电子產品世界
.com.cn

74F195A

4-bit parallel-access shift register

Product specification

1996 Mar 12

IC15 Data Handbook

4-bit parallel-access shift register

74F195A

FEATURES

- Shift right and parallel load capability
- J – \bar{K} (D) inputs to first stage
- Complement output from last stage
- Asynchronous Master Reset
- Diode inputs

DESCRIPTION

The 74F195A is a 4-Bit Parallel Access Shift Register and its functional characteristics are indicated in the Logic Diagram and Function Table. This device is useful in a variety of shifting, counting and storage applications. It performs serial, parallel, serial to parallel, or parallel to serial data transfers at very high speeds.

The 74F195A operates in two primary modes: shift right ($Q_0 \rightarrow Q_1$) and parallel load, which are controlled by the state of the Parallel Enable (\overline{PE}) input. Serial data enters the first flip-flop (Q_0) via the J and K inputs when the \overline{PE} input is High, and is shifted one bit in the direction $Q_0 \rightarrow Q_1 \rightarrow Q_2 \rightarrow Q_3$ following each Low-to-High clock transition.

The J and \bar{K} inputs provide the flexibility of the J- \bar{K} type input for special applications, and by tying the two together the simple D-type input is made for general applications.

The device appears as four common clocked D flip-flops when the \overline{PE} input is Low. After the Low-to-High clock transition, data on the parallel inputs (D0–D3) is transferred to the respective Q_0 – Q_3 outputs. Shift left operation ($Q_3 \rightarrow Q_2$) can be achieved by tying the Q_n outputs to the D_{n-1} inputs and holding the \overline{PE} input Low.

All parallel and serial data transfers are synchronous, occurring after each Low-to-High clock transition. The 74F195A utilizes edge-triggering, therefore there is no restriction on the activity of the

J, \bar{K} , D_n , and \overline{PE} inputs for logic operation, other than the set-up and hold time requirements.

A Low on the asynchronous Master Reset (\overline{MR}) input sets all Q outputs Low, independent of any other input condition.

PIN CONFIGURATION

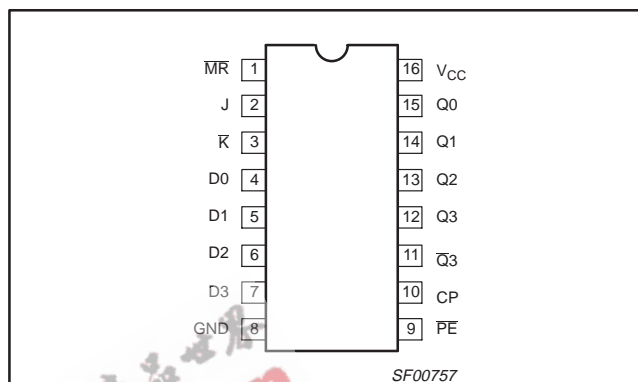

TYPE	TYPICAL f_{MAX}	TYPICAL SUPPLY CURRENT (TOTAL)
74F195A	180MHz	40mA

ORDERING INFORMATION

DESCRIPTION	COMMERCIAL RANGE $V_{CC} = 5V \pm 10\%$, $T_{amb} = 0^\circ C$ to $+70^\circ C$	PKG. DWG. #
16-pin plastic DIP	N74F195AN	SOT 38-4
16-pin plastic SO	N74F195AD	SOT 109-1

INPUT AND OUTPUT LOADING AND FAN-OUT TABLE

PINS	DESCRIPTION	74F (U.L.) HIGH/LOW	LOAD VALUE HIGH/LOW
D0–D3	Data inputs	74F195	1.0/0.033
		74F195A	1.0/1.0
J, \bar{K}	J-K or D type serial inputs	74F195	1.0/0.033
		74F195A	1.0/1.0
CP	Clock Pulse input (active rising edge)	74F195	1.0/0.033
		74F195A	1.0/1.0
\overline{MR}	Master Reset input (active Low)	74F195	2.0/0.066
		74F195A	1.0/1.0
Q_0 – Q_3 , \bar{Q}_3	Data outputs	50/33	1.0mA/20mA

NOTE:

One (1.0) FAST unit load is defined as: 20 μ A in the High state and 0.6mA in the Low state.

4-bit parallel-access shift register

74F195A

LOGIC SYMBOL

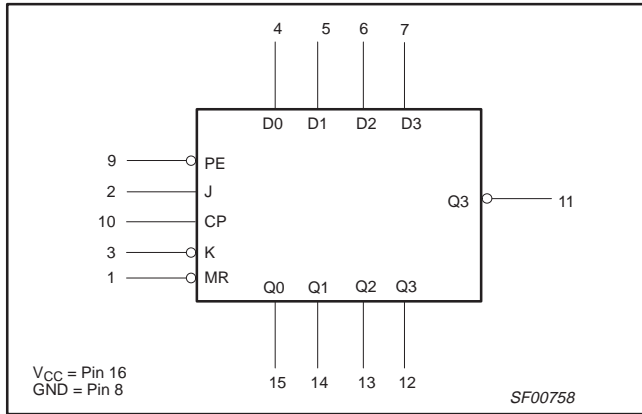

IEC/IEEE SYMBOL

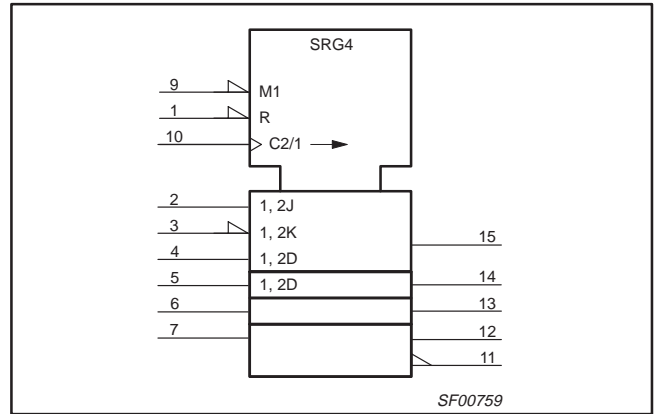

LOGIC DIAGRAM

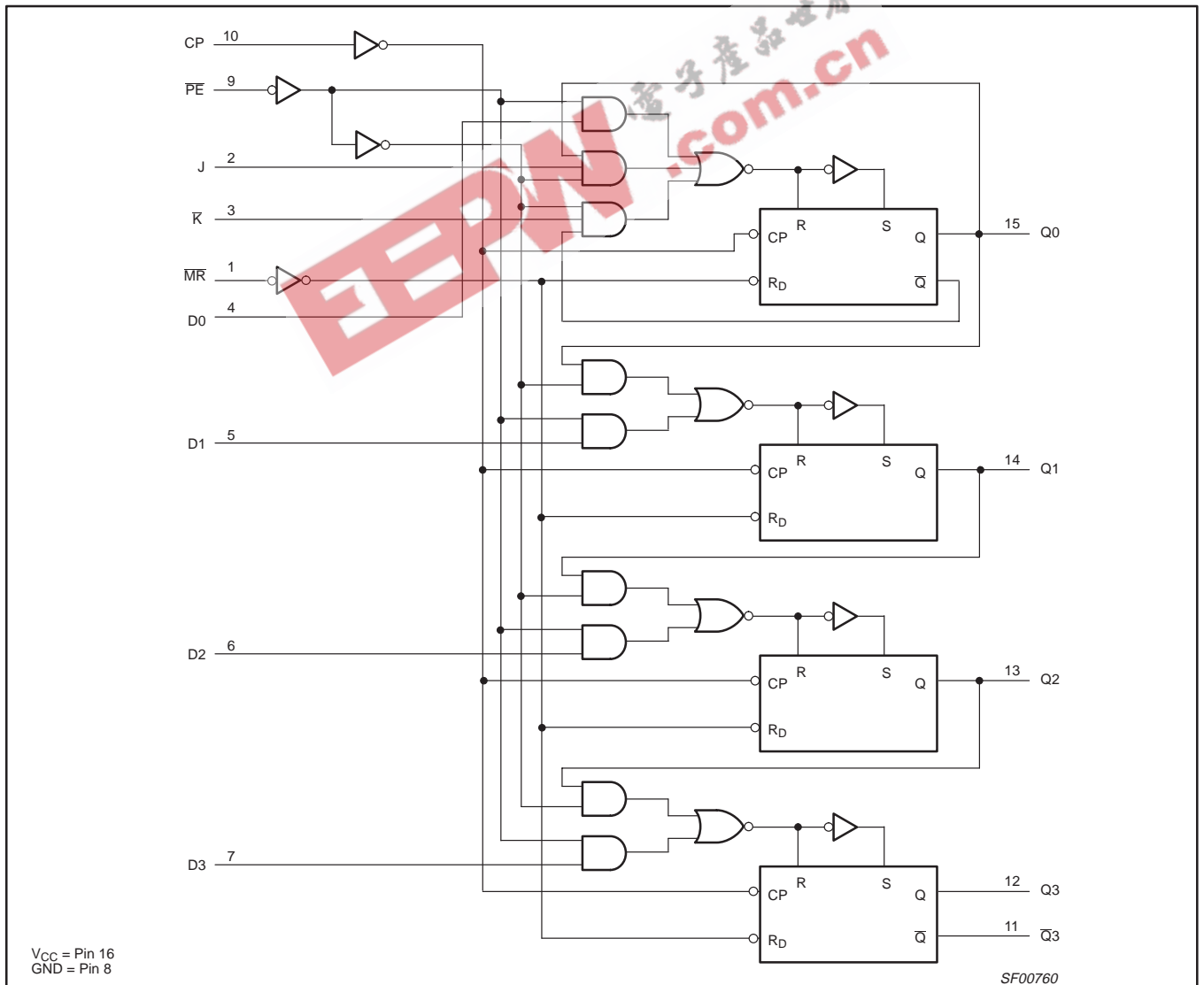

4-bit parallel-access shift register

74F195A

FUNCTION TABLE

INPUTS						OUTPUTS					OPERATING MODES
\overline{MR}	CP	\overline{PE}	J	\overline{K}	Dn	Q0	Q1	Q2	Q3	$\overline{Q3}$	
L	X	X	X	X	X	L	L	L	L	H	Reset (clear)
H	↑	h	h	h	X	H	q0	q1	q2	$\overline{q2}$	Shift, set First stage
H	↑	h	l	l	X	L	q0	q1	q2	$\overline{q2}$	Shift, reset First stage
H	↑	h	h	l	X	$\overline{q0}$	q0	q1	q2	$\overline{q2}$	Shift, toggle First stage
H	↑	h	l	h	X	q0	q0	q1	q2	$\overline{q2}$	Shift, retain First stage

H = High voltage level

h = High voltage level one setup time prior to Low-to-High clock transition

L = Low voltage level

l = Low voltage level one setup time prior to Low-to-High clock transition

X = Don't care

↑ = Low-to-High clock transition

dn(qn) = Lower case letters indicate the state of the referenced input (or output) one setup time prior to the Low-to-High clock transition.

ABSOLUTE MAXIMUM RATINGS

(Operation beyond the limits set forth in this table may impair the useful life of the device.)

Unless otherwise noted these limits are over the operating free-air temperature range.)

SYMBOL	PARAMETER	RATING	UNIT
V _{CC}	Supply voltage	-0.5 to +7.0	V
V _{IN}	Input voltage	-0.5 to +7.0	V
I _{IN}	Input current	-30 to +5	mA
V _{OUT}	Voltage applied to output in High output state	-0.5 to +V _{CC}	V
I _{OUT}	Current applied to output in Low output state	40	mA
T _{amb}	Operating free-air temperature range	0 to +70	°C
T _{stg}	Storage temperature	-65 to +150	°C

RECOMMENDED OPERATING CONDITIONS

SYMBOL	PARAMETER	LIMITS			UNIT
		MIN	NOM	MAX	
V _{CC}	Supply voltage	4.5	5.0	5.5	V
V _{IH}	High-level input voltage	2.0			V
V _{IL}	Low-level input voltage			0.8	V
I _{IK}	Input clamp current			-18	mA
I _{OH}	High-level output current			-1	mA
I _{OL}	Low-level output current			20	mA
T _{amb}	Operating free-air temperature range	0		70	°C

4-bit parallel-access shift register

74F195A

DC ELECTRICAL CHARACTERISTICS

(Over recommended operating free-air temperature range unless otherwise noted.)

SYMBOL	PARAMETER	TEST CONDITIONS ^{NO TAG}		LIMITS			UNIT
				MIN	TYP NO TAG	MAX	
V _{OH}	High-level output voltage	V _{CC} = MIN, V _{IL} = MAX V _{IH} = MIN, I _{OH} = MAX	±10%V _{CC}	2.5			V
			±5%V _{CC}	2.7	3.4		V
V _{OL}	Low-level output voltage	V _{CC} = MIN, V _{IL} = MAX V _{IH} = MIN, I _{OL} = MAX	±10%V _{CC}		0.35	0.50	V
			±5%V _{CC}		0.35	0.50	
V _{IK}	Input clamp voltage	V _{CC} = MIN, I _I = I _{IK}			-0.73	-1.2	V
I _I	Input current at maximum input voltage	V _{CC} = MAX, V _I = 7.0V	74F195A			100	μA
I _{IH}	High-level input current	V _{CC} = MAX, V _I = 2.7V	all others			20	μA
I _{IL}	Low-level input current	V _{CC} = MAX, V _I = 0.5V	74F195A			-600	mA
I _{OS}	Short-circuit output current ³	V _{CC} = MAX		-60		-150	mA
I _{CC}	Supply current (total)	V _{CC} = MAX	74F195A		40	58	mA

NOTES:

- For conditions shown as MIN or MAX, use the appropriate value specified under recommended operating conditions for the applicable type.
- All typical values are at V_{CC} = 5V, T_{amb} = 25°C.
- Not more than one output should be shorted at a time. For testing I_{OS}, the use of high-speed test apparatus and/or sample-and-hold techniques are preferable in order to minimize internal heating and more accurately reflect operational values. Otherwise, prolonged shorting of a High output may raise the chip temperature well above normal and thereby cause invalid readings in other parameter tests. In any sequence of parameter tests, I_{OS} tests should be performed last.

AC ELECTRICAL CHARACTERISTICS

SYMBOL	PARAMETER		TEST CONDITION	LIMITS					UNIT
				V _{CC} = +5V T _{amb} = +25°C C _L = 50pF, R _L = 500Ω			V _{CC} = +5V ± 10% T _{amb} = 0°C to +70°C C _L = 50pF, R _L = 500Ω		
				MIN	TYP	MAX	MIN	MAX	
f _{MAX}	Maximum clock frequency	Load mode	Waveform NO TAG	165	180		150		MHz
		Shift mode		180	190		170		
t _{PLH} t _{PHL}	Propagation delay CP to Q _n		Waveform NO TAG	3.0 2.5	5.0 4.0	9.5 7.0	2.5 2.0	10.0 7.5	ns
t _{PLH} t _{PHL}	Propagation delay CP to Q ₃		Waveform NO TAG	2.0 2.0	5.5 4.0	9.5 6.5	2.5 2.0	9.5 7.0	ns
t _{PHL}	Propagation delay MR to Q _n		Waveform 2	2.0	4.0	7.0	2.0	7.0	ns
t _{PLH}	Propagation delay MR to Q ₃		Waveform 2	2.5	4.5	8.0	2.0	10.0	ns

4-bit parallel-access shift register

74F195A

AC SETUP REQUIREMENTS

SYMBOL	PARAMETER	TEST CONDITION	LIMITS					UNIT
			V _{CC} = +5V T _{amb} = +25°C C _L = 50pF, R _L = 500Ω			V _{CC} = +5V ± 10% T _{amb} = 0°C to +70°C C _L = 50pF, R _L = 500Ω		
			MIN	TYP	MAX	MIN	MAX	
t _S (H) t _S (L)	Setup time, High or Low J, K and Dn to CP	Waveform 3	2.5 2.5			2.5 2.5		ns
t _H (H) t _H (L)	Hold time, High or Low J, K and Dn to CP	Waveform 3	0.0 1.0			0.0 1.0		ns
t _S (H) t _S (L)	Setup time, High or Low PE to CP	Waveform 4	2.0 2.5			2.0 2.5		ns
t _H (H) t _H (L)	Hold time, High or Low PE to CP	Waveform 4	0.0 0.0			0.0 0.0		ns
t _W (H)	CP Pulse width High	Waveform NO TAG	4.5			4.5		ns
t _W (L)	MR Pulse width Low	Waveform 2	4.5			4.5		ns
t _{REC}	Recovery time MR to CP	Waveform 2	2.5			3.0		ns

AC WAVEFORMS

For all waveforms, V_M = 1.5V.

The shaded areas indicate when the input is permitted to change for predictable output performance.

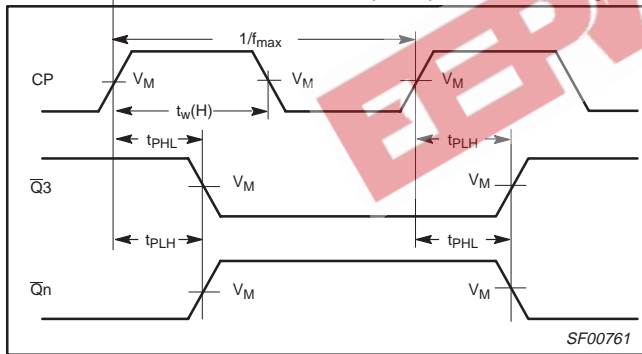

Waveform 1. Propagation Delay, Clock Input to Output, Clock Pulse Width, and Maximum Clock Frequency

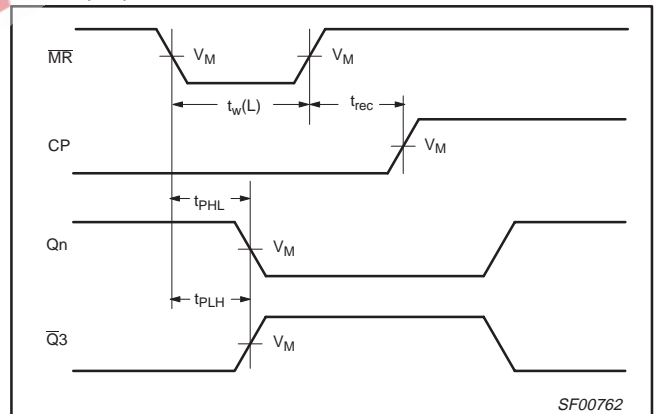

Waveform 3. Master Reset Pulse Width, Master Reset to Output Delay, and Master Reset to Clock Recovery Time

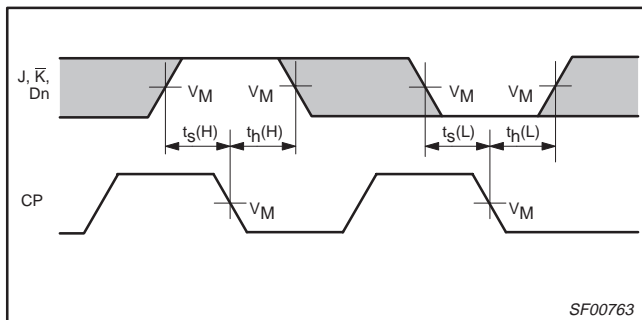

Waveform 2. Data Setup and Hold Times

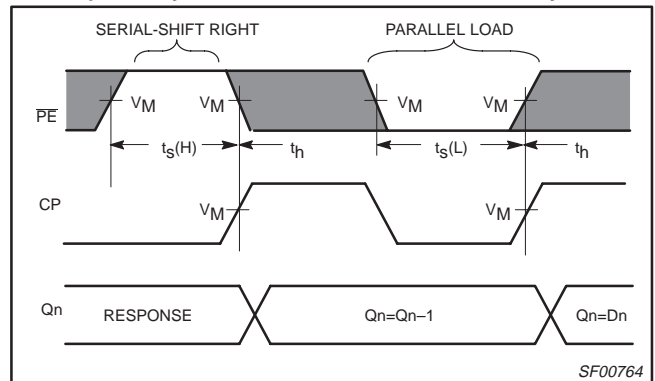

Waveform 4. Setup and Hold Times, Parallel Enable to Clock

4-bit parallel-access shift register

74F195A

TEST CIRCUIT AND WAVEFORMS

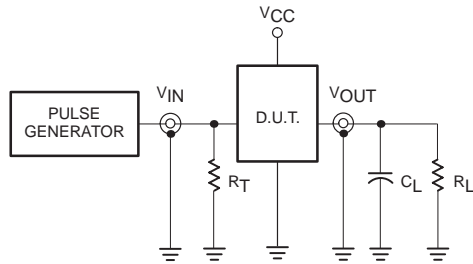

Test Circuit for Totem-Pole Outputs

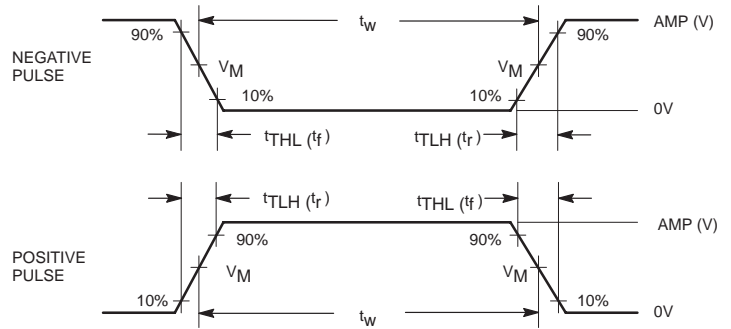

Input Pulse Definition

DEFINITIONS:

- R_L = Load resistor; see AC ELECTRICAL CHARACTERISTICS for value.
- C_L = Load capacitance includes jig and probe capacitance; see AC ELECTRICAL CHARACTERISTICS for value.
- R_T = Termination resistance should be equal to Z_{OUT} of pulse generators.

family	INPUT PULSE REQUIREMENTS					
	amplitude	V_M	rep. rate	t_w	t_{TLH}	t_{THL}
74F	3.0V	1.5V	1MHz	500ns	2.5ns	2.5ns

SF00006

4-bit parallel-access shift register

74F195A

DIP16: plastic dual in-line package; 16 leads (300 mil)

SOT38-4

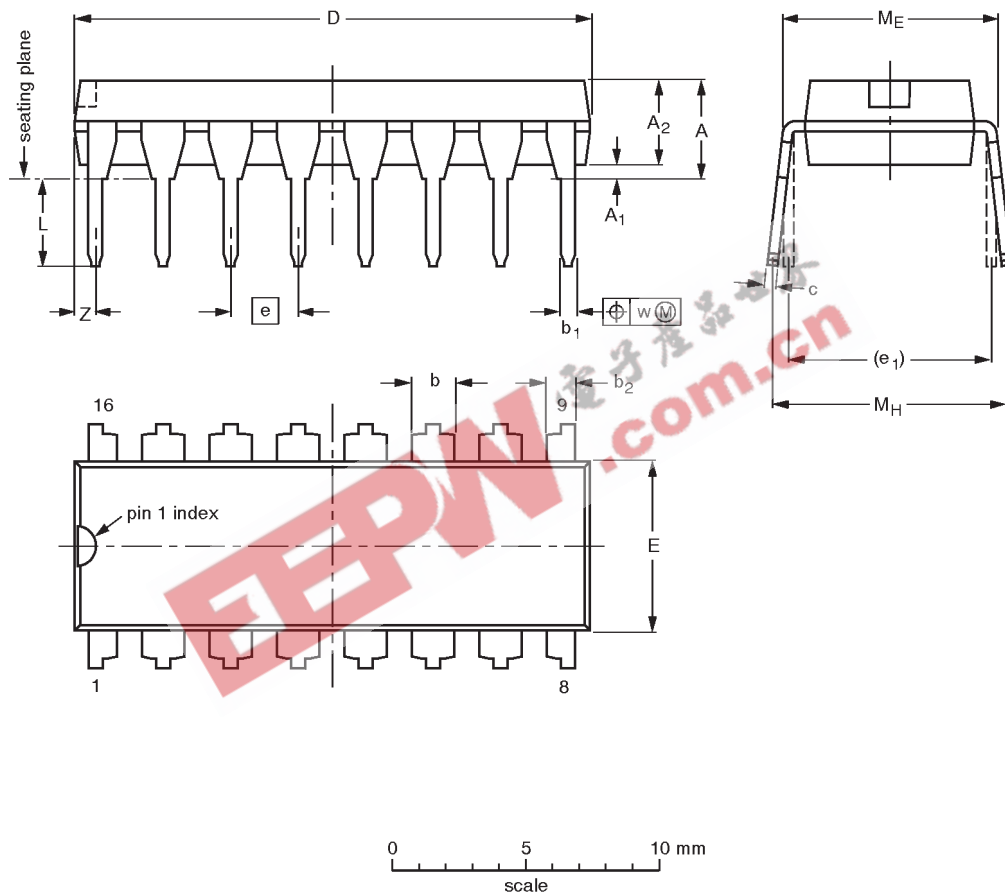

DIMENSIONS (inch dimensions are derived from the original mm dimensions)

UNIT	A max.	A ₁ min.	A ₂ max.	b	b ₁	b ₂	c	D ⁽¹⁾	E ⁽¹⁾	e	e ₁	L	M _E	M _H	w	z ⁽¹⁾ max.
mm	4.2	0.51	3.2	1.73 1.30	0.53 0.38	1.25 0.85	0.36 0.23	19.50 18.55	6.48 6.20	2.54	7.62	3.60 3.05	8.25 7.80	10.0 8.3	0.254	0.76
inches	0.17	0.020	0.13	0.068 0.051	0.021 0.015	0.049 0.033	0.014 0.009	0.77 0.73	0.26 0.24	0.10	0.30	0.14 0.12	0.32 0.31	0.39 0.33	0.01	0.030

Note

1. Plastic or metal protrusions of 0.25 mm maximum per side are not included.

OUTLINE VERSION	REFERENCES				EUROPEAN PROJECTION	ISSUE DATE
	IEC	JEDEC	EIAJ			
SOT38-4						92-11-17 95-01-14

4-bit parallel-access shift register

74F195A

NOTES



4-bit parallel-access shift register

74F195A

Data sheet status

Data sheet status	Product status	Definition [1]
Objective specification	Development	This data sheet contains the design target or goal specifications for product development. Specification may change in any manner without notice.
Preliminary specification	Qualification	This data sheet contains preliminary data, and supplementary data will be published at a later date. Philips Semiconductors reserves the right to make changes at any time without notice in order to improve design and supply the best possible product.
Product specification	Production	This data sheet contains final specifications. Philips Semiconductors reserves the right to make changes at any time without notice in order to improve design and supply the best possible product.

[1] Please consult the most recently issued datasheet before initiating or completing a design.

Definitions

Short-form specification — The data in a short-form specification is extracted from a full data sheet with the same type number and title. For detailed information see the relevant data sheet or data handbook.

Limiting values definition — Limiting values given are in accordance with the Absolute Maximum Rating System (IEC 134). Stress above one or more of the limiting values may cause permanent damage to the device. These are stress ratings only and operation of the device at these or at any other conditions above those given in the Characteristics sections of the specification is not implied. Exposure to limiting values for extended periods may affect device reliability.

Application information — Applications that are described herein for any of these products are for illustrative purposes only. Philips Semiconductors make no representation or warranty that such applications will be suitable for the specified use without further testing or modification.

Disclaimers

Life support — These products are not designed for use in life support appliances, devices or systems where malfunction of these products can reasonably be expected to result in personal injury. Philips Semiconductors customers using or selling these products for use in such applications do so at their own risk and agree to fully indemnify Philips Semiconductors for any damages resulting from such application.

Right to make changes — Philips Semiconductors reserves the right to make changes, without notice, in the products, including circuits, standard cells, and/or software, described or contained herein in order to improve design and/or performance. Philips Semiconductors assumes no responsibility or liability for the use of any of these products, conveys no license or title under any patent, copyright, or mask work right to these products, and makes no representations or warranties that these products are free from patent, copyright, or mask work right infringement, unless otherwise specified.

Philips Semiconductors
811 East Arques Avenue
P.O. Box 3409
Sunnyvale, California 94088-3409
Telephone 800-234-7381

© Copyright Philips Electronics North America Corporation 1998
All rights reserved. Printed in U.S.A.

print code

Date of release: 10-98

Document order number:

9397-750-05096

Let's make things better.