

CD40160B, CD40161B, CD40162B, CD40163B Types

CMOS Synchronous Programmable 4-Bit Counters

High-Voltage Types (20-Volt Rating)

- CD40160B – Decade with Asynchronous Clear
- CD40161B – Binary with Asynchronous Clear
- CD40162B – Decade with Synchronous Clear
- CD40163B – Binary with Synchronous Clear

■ CD40160B, CD40161B, CD40162B, and CD40163B are 4-bit synchronous programmable counters. The CLEAR function of the CD40162B and CD40163B is synchronous and a low level at the CLEAR input sets all four outputs low on the next positive CLOCK edge. The CLEAR function of the CD40160B and CD40161B is asynchronous and a low level at the CLEAR input sets all four outputs low regardless of the state of the CLOCK, LOAD, or ENABLE inputs. A low level at the LOAD input disables the counter and causes the output to agree with the setup data after the next CLOCK pulse regardless of the conditions of the ENABLE inputs.

The carry look-ahead circuitry provides for cascading counters for n-bit synchronous applications without additional gating. Instrumental in accomplishing this function are two count-enable inputs and a carry output (C_{OUT}). Counting is enabled when both PE and TE inputs are high. The TE input is fed forward to enable C_{OUT}. This enabled output produces a positive output pulse with a

Features:

- Internal look-ahead for fast counting
- Carry output for cascading
- Synchronously programmable
- Clear asynchronous input (CD40160B, CD40161B)
- Clear synchronous input (CD40162B, CD40163B)
- Synchronous load control input
- Low-power TTL compatibility
- Standardized, symmetrical output characteristics
- 100% tested for quiescent current at 20 V
- Maximum input current of 1 μA at 18 V over full package-temperature range; 100 nA at 18 V and 25°C
- Noise margin (over full package-temperature range): 1 V at V_{DD} = 5 V
2 V at V_{DD} = 10 V 2.5 V at V_{DD} = 15 V
- 5-V, 10-V, and 15-V parametric ratings
- Meets all requirements of JEDEC Tentative Standard No. 13B, "Standard Specifications for Description of 'B' Series CMOS Devices"

duration approximately equal to the positive portion of the Q1 output. This positive overflow carry pulse can be used to enable successive cascaded stages. Logic transitions at the PE or TE inputs may occur when the clock is either high or low.

The CD40160B, CD40161B, CD40162B, and CD40163B types are supplied in 16-lead hermetic dual-in-line ceramic packages (D and F suffixes), 16-lead dual-in-line plastic packages (E suffix), and in chip form (H suffix).

The CD40160B through CD40163B types are functionally equivalent to and pin-compatible with the TTL counter series 74LS160 through 74LS163 respectively.

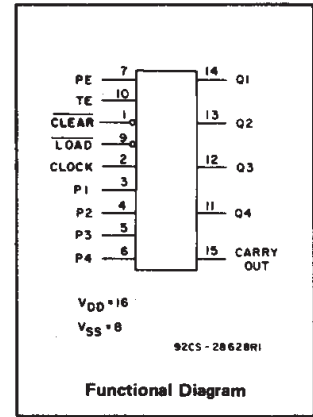

Applications:

- Programmable binary and decade counting
- Counter control/timers
- Frequency dividing

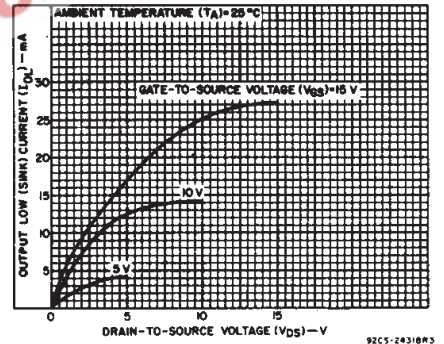

Fig. 1— Typical output low (sink) current characteristics.

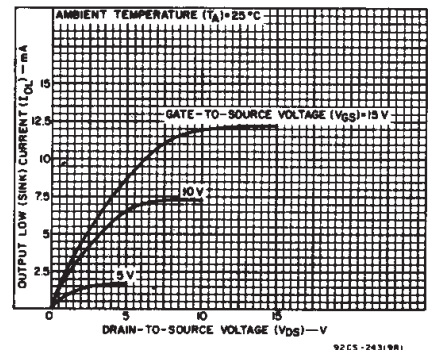

Fig. 2— Minimum output low (sink) current characteristics.

MAXIMUM RATINGS, Absolute-Maximum Values:

DC SUPPLY-VOLTAGE RANGE, (V _{DD})	
Voltages referenced to V _{SS} Terminal	–0.5V to +20V
INPUT VOLTAGE RANGE, ALL INPUTS	–0.5V to V _{DD} +0.5V
DC INPUT CURRENT, ANY ONE INPUT	±10mA
POWER DISSIPATION PER PACKAGE (P _D):	
For T _A = –55°C to +100°C	500mW
For T _A = +100°C to +125°C	Derate Linearly at 12mW/°C to 200mW
DEVICE DISSIPATION PER OUTPUT TRANSISTOR	
FOR T _A = FULL PACKAGE-TEMPERATURE RANGE (All Package Types)	100mW
OPERATING-TEMPERATURE RANGE (T _A)	–55°C to +125°C
STORAGE TEMPERATURE RANGE (T _{stg})	–65°C to +150°C
LEAD TEMPERATURE (DURING SOLDERING):	
At distance 1/16 ± 1/32 inch (1.59 ± 0.79mm) from case for 10s max	+265°C

3
COMMERCIAL CMOS
HIGH VOLTAGE ICs

CD40160B, CD40161B, CD40162B, CD40163B Types

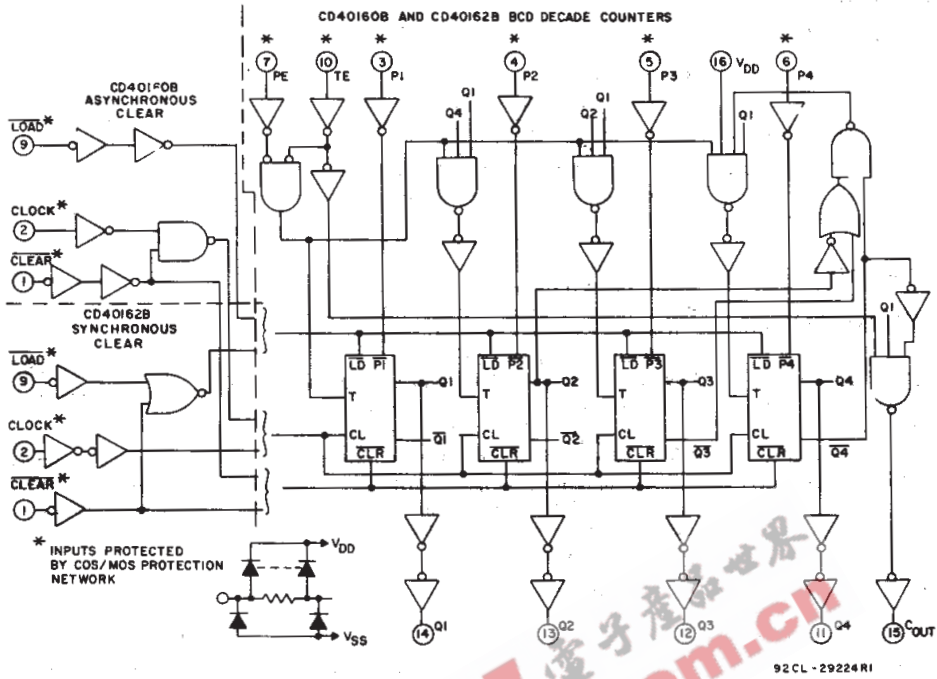

Fig. 3— Logic diagrams for CD40160B and CD40162B BCD decade counters.

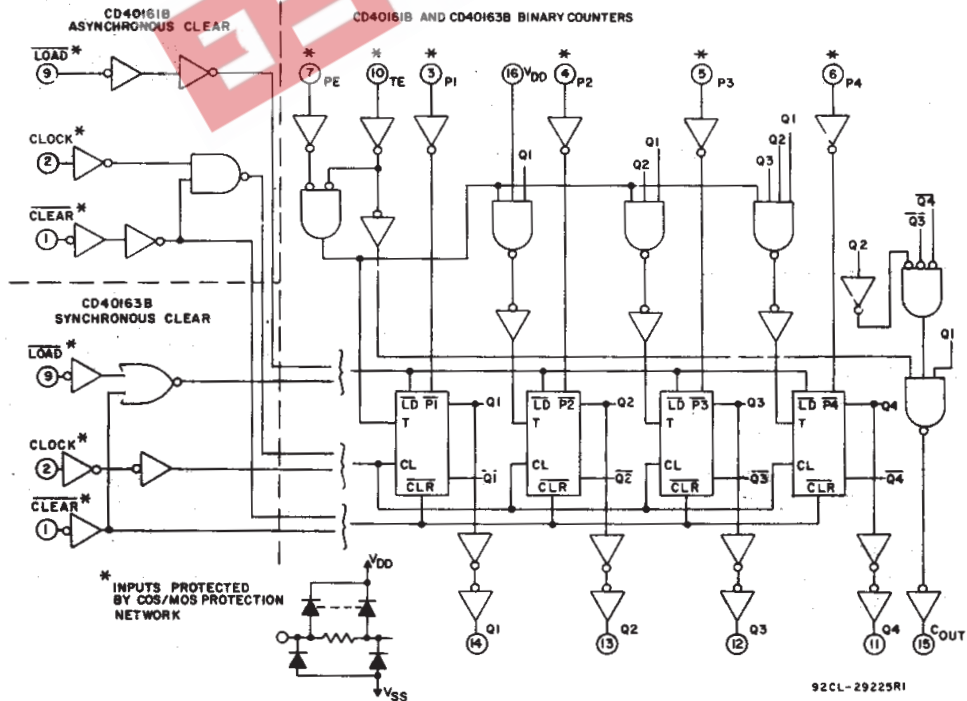

Fig. 4— Logic diagrams for CD40161B and CD40163B binary counters.

CD40160B, CD40161B, CD40162B, CD40163B Types

RECOMMENDED OPERATING CONDITIONS at $T_A = 25^\circ\text{C}$, Except as Noted
 For maximum reliability, nominal operating conditions should be selected so that operation is always within the following ranges:

CHARACTERISTIC	V _{DD} (V)	LIMITS		UNITS
		MIN.	MAX.	
Supply Voltage Range (Full T _A = Full Package-Temperature Range)	—	3	18	V
Setup Time: t _{SU} Data to Clock	5	240	—	ns
	10	90	—	
	15	60	—	
Load to Clock	5	240	—	ns
	10	90	—	
	15	60	—	
PE or TE to Clock	5	340	—	ns
	10	140	—	
	15	100	—	
Clear to Clock (CD40162B, CD40163B)	5	340	—	ns
	10	140	—	
	15	100	—	
All Hold Times, t _H	5	0	—	ns
	10	0	—	
	15	0	—	
Clear Removal Time, t _{rem} (CD40160B, CD40161B)	5	200	—	ns
	10	100	—	
	15	70	—	
Clear Pulse Width, t _{WL} (CD40160B, CD40161B)	5	170	—	ns
	10	70	—	
	15	50	—	
Clock Input Frequency, f _{CL}	5	—	2	MHz
	10	—	5.5	
	15	—	8	
Clock Pulse Width, t _W	5	170	—	ns
	10	70	—	
	15	50	—	
Clock Rise or Fall Time, t _r CL or t _f CL	5	—	200	μs
	10	—	70	
	15	—	15	

TRUTH TABLE

CLOCK	CLR	LOAD	PE	TE	OPERATION
	1	0	X	X	PRESET
	1	1	0	X	NC
	1	1	X	0	NC
	1	1	1	1	COUNT
X	0	X	X	X	RESET (CD40160B, CD40161B)
	0	X	X	X	RESET (CD40162B, CD40163B)
	1	X	X	X	NC (CD40162B, CD40163B)

1 = HIGH LEVEL 0 = LOW LEVEL X = DON'T CARE NC = NO CHANGE

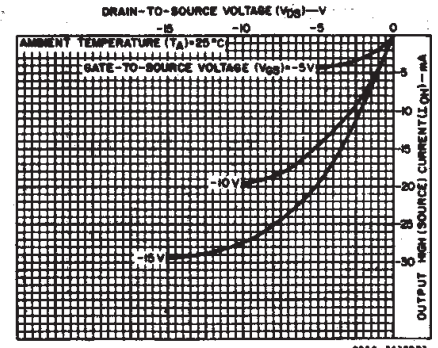

Fig. 5—Typical output high (source) current characteristics.

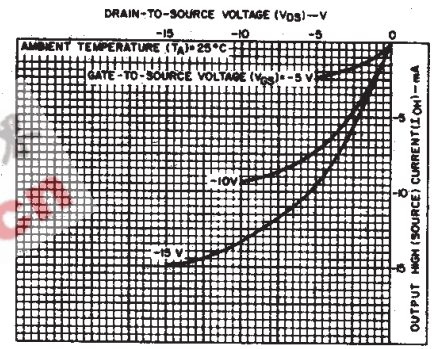

Fig. 6—Minimum output high (source) current characteristics.

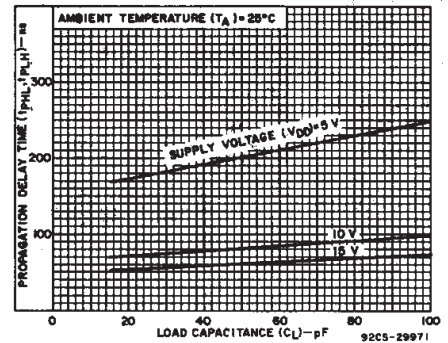

Fig. 7—Typical propagation delay time as a function of load capacitance (CLOCK to Q).

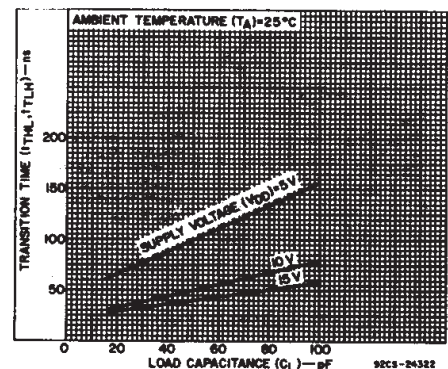

Fig. 8—Typical transition time as a function of load capacitance.

CD40160B, CD40161B, CD40162B, CD40163B Types

STATIC ELECTRICAL CHARACTERISTICS

CHARACTERISTIC	CONDITIONS			LIMITS AT INDICATED TEMPERATURES (°C)							UNITS
	V _O (V)	V _{IN} (V)	V _{DD} (V)	-55	-40	+85	+125	+25			
								Min.	Typ.	Max.	
Quiescent Device Current, I _{DD} Max.	—	0.5	5	5	5	150	150	—	0.04	5	μA
	—	0.10	10	10	10	300	300	—	0.04	10	
	—	0.15	15	20	20	600	600	—	0.04	20	
	—	0.20	20	100	100	3000	3000	—	0.08	100	
Output Low (Sink) Current I _{OL} Min.	0.4	0.5	5	0.64	0.61	0.42	0.36	0.51	1	—	mA
	0.5	0.10	10	1.6	1.5	1.1	0.9	1.3	2.6	—	
	1.5	0.15	15	4.2	4	2.8	2.4	3.4	6.8	—	
Output High (Source) Current, I _{OH} Min.	4.6	0.5	5	-0.64	-0.61	-0.42	-0.36	-0.51	-1	—	mA
	2.5	0.5	5	-2	-1.8	-1.3	-1.15	-1.6	-3.2	—	
	9.5	0.10	10	-1.6	-1.5	-1.1	-0.9	-1.3	-2.6	—	
	13.5	0.15	15	-4.2	-4	-2.8	-2.4	-3.4	-6.8	—	
Output Voltage: Low-Level, V _{OL} Max.	—	0.5	5	0.05				—	0	0.05	V
	—	0.10	10	0.05				—	0	0.05	
	—	0.15	15	0.05				—	0	0.05	
Output Voltage: High-Level, V _{OH} Min.	—	0.5	5	4.95				4.95	5	—	V
	—	0.10	10	9.95				9.95	10	—	
	—	0.15	15	14.95				14.95	15	—	
Input Low Voltage V _{IL} Max.	0.5, 4.5	—	5	1.5				—	—	1.5	V
	1.9	—	10	3				—	—	3	
	1.5, 13.5	—	15	4				—	—	4	
Input High Voltage, V _{IH} Min.	0.5, 4.5	—	5	3.5				3.5	—	—	V
	1.9	—	10	7				7	—	—	
	1.5, 13.5	—	15	11				11	—	—	
Input Current I _{IN} Max.	—	0.18	18	±0.1	±0.1	±1	±1	—	±10 ⁻⁵	±0.1	μA

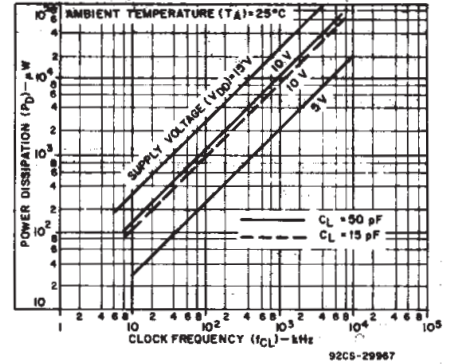

Fig. 9— Typical power dissipation as a function of CLOCK frequency.

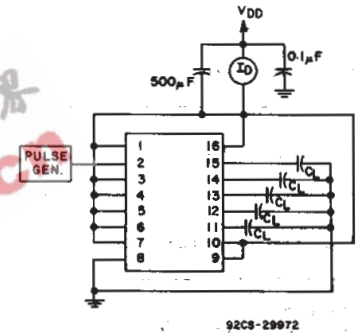

Fig. 10— Dynamic power dissipation test circuit.

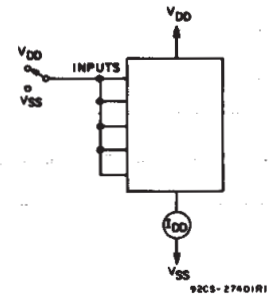

Fig. 11— Quiescent device current test circuit.

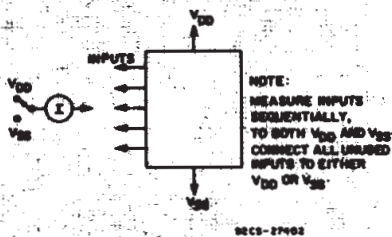

Fig. 12— Input current test circuit.

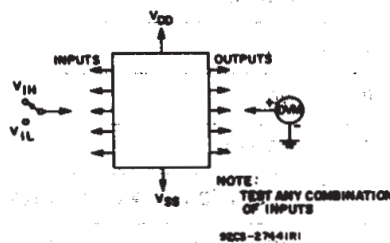

Fig. 13— Input voltage test circuit.

TERMINAL ASSIGNMENT

CLEAR	1	16	V _{DD}
CLOCK	2	15	CARRY OUT
P1	3	14	Q1
PE	4	13	Q2
P0	5	12	Q3
P4	6	11	Q4
PE	7	10	TE
VSS	8	9	LOAD

92CS-29459

CD40160B, CD40161B, CD40162B, CD40163B Types

DYNAMIC ELECTRICAL CHARACTERISTICS at $T_A = 25^\circ\text{C}$;
 Input $t_r, t_f = 20 \text{ ns}$, $C_L = 50 \text{ pF}$, $R_L = 200 \text{ k}\Omega$

CHARACTERISTIC	TEST CONDITIONS V_{DD} (V)	LIMITS ALL TYPES*			UNITS
		Min.	Typ.	Max.	
CLOCK OPERATION					
Propagation Delay Time, t_{PHL}, t_{PLH} Clock to Q	5	—	200	400	ns
	10	—	80	160	
	15	—	60	120	
Clock to C_{OUT}	5	—	225	450	ns
	10	—	95	190	
	15	—	70	140	
TE to C_{OUT}	5	—	125	250	ns
	10	—	55	110	
	15	—	40	80	
Minimum Setup Time, t_{SU} Data to Clock	5	—	120	240	ns
	10	—	45	90	
	15	—	30	60	
Load to Clock	5	—	120	240	ns
	10	—	45	90	
	15	—	30	60	
PE to TE to Clock	5	—	170	340	ns
	10	—	70	140	
	15	—	50	100	
Minimum Hold Time, t_H	5	—	—	0	ns
	10	—	—	0	
	15	—	—	0	
Transition Time, t_{THL}, t_{TLH}	5	—	100	200	ns
	10	—	50	100	
	15	—	40	80	
Minimum Clock Pulse Width, t_W	5	—	85	170	ns
	10	—	35	70	
	15	—	25	50	
Maximum Clock Frequency, f_{CL}	5	2	3	—	MHz
	10	5.5	8.5	—	
	15	8	12	—	
Maximum Clock Rise or Fall Time,† t_{rCL}, t_{fCL}	5	200	—	—	μs
	10	70	—	—	
	15	15	—	—	
CLEAR OPERATION					
Propagation Delay Time, t_{PHL} (CD40160B, CD40161B) Clear to Q	5	—	250	500	ns
	10	—	110	220	
	15	—	80	160	
Minimum Setup Time, t_{SU} (CD40162B, CD40163B) Clear to Clock	5	—	170	340	ns
	10	—	70	140	
	15	—	50	100	
Minimum Hold Time, t_H (CD40162B, CD40163B) Clear to Clock	5	—	—	0	ns
	10	—	—	0	
	15	—	—	0	
Minimum Clear Removal Time, t_{rem} (CD40160B, CD40161B)	5	—	100	200	ns
	10	—	50	100	
	15	—	35	70	
Minimum Clear Pulse Width, t_{WL} (CD40160B, CD40161B)	5	—	85	170	ns
	10	—	35	70	
	15	—	25	50	

* Except as noted.

† If more than one unit is cascaded in the parallel clocked application, t_{rCL} should be made less than or equal to the sum of the fixed propagation delay at 50 pF and the transition time of the carry output driving stage for the estimated capacitive load.

3
COMMERCIAL CMOS
HIGH VOLTAGE ICs

CD40160B, CD40161B, CD40162B, CD40163B Types

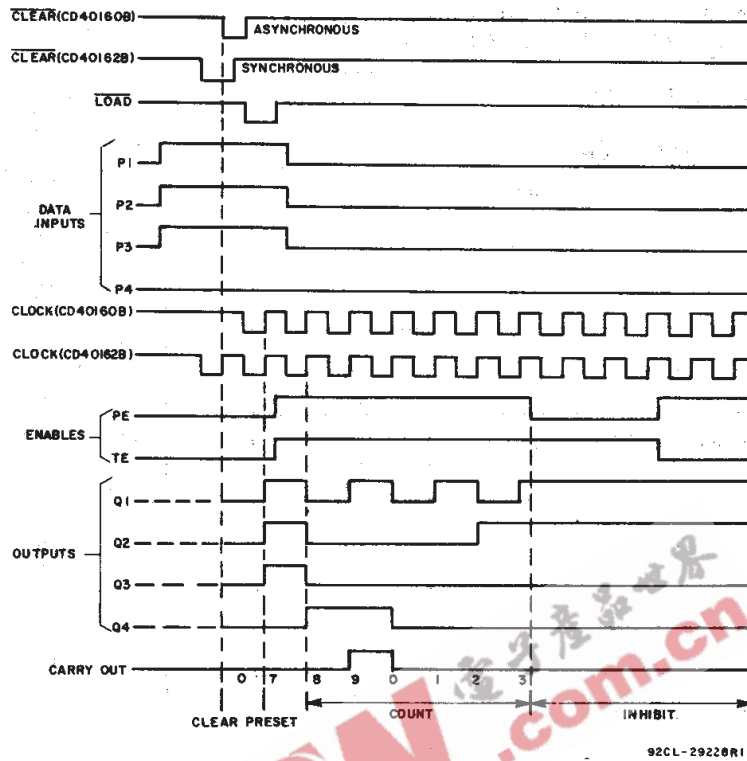

Fig. 14—Timing diagram for CD40160B, CD40162B.

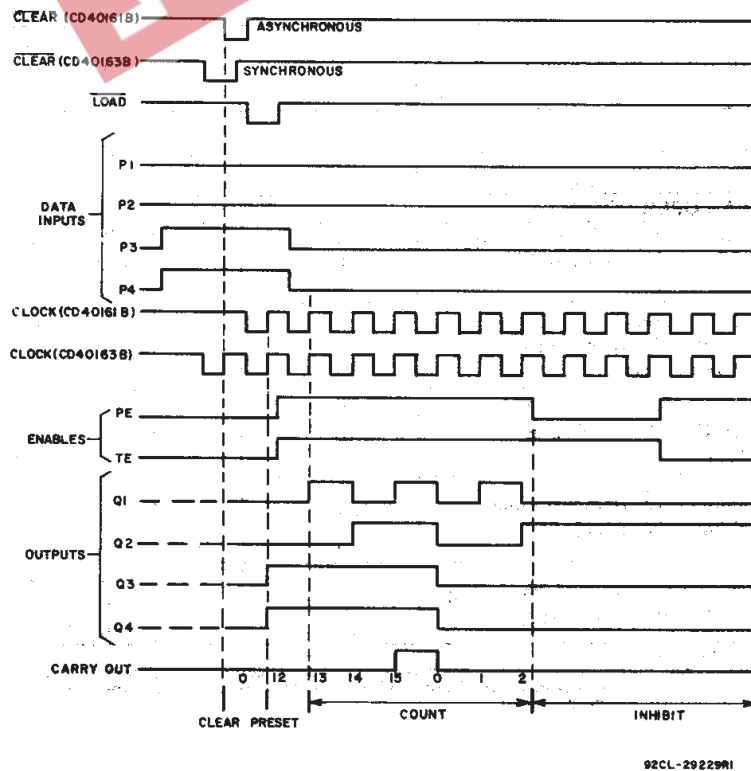

Fig. 15—Timing diagram for CD40161B, CD40163B.

CD40160B, CD40161B, CD40162B, CD40163B Types

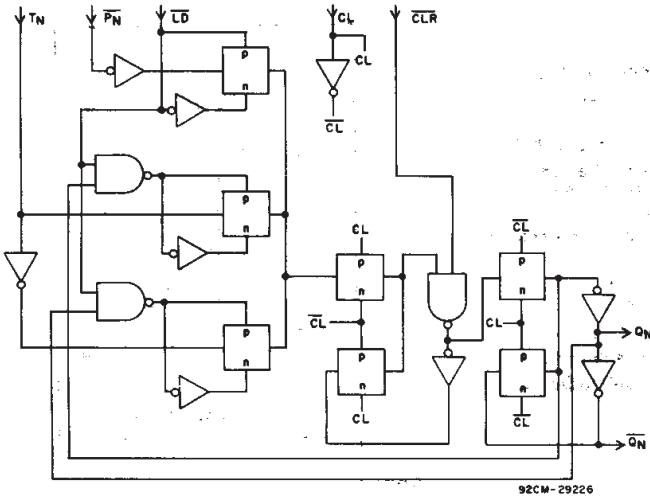

Fig. 16— Detail of flip-flops of CD40160B and CD40161B (asynchronous clear).

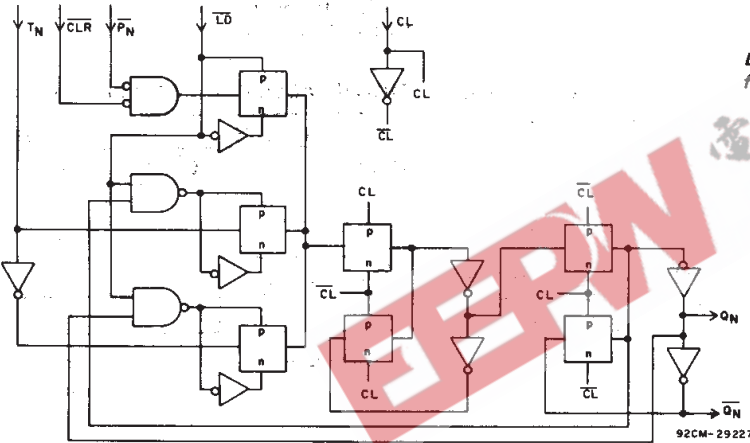
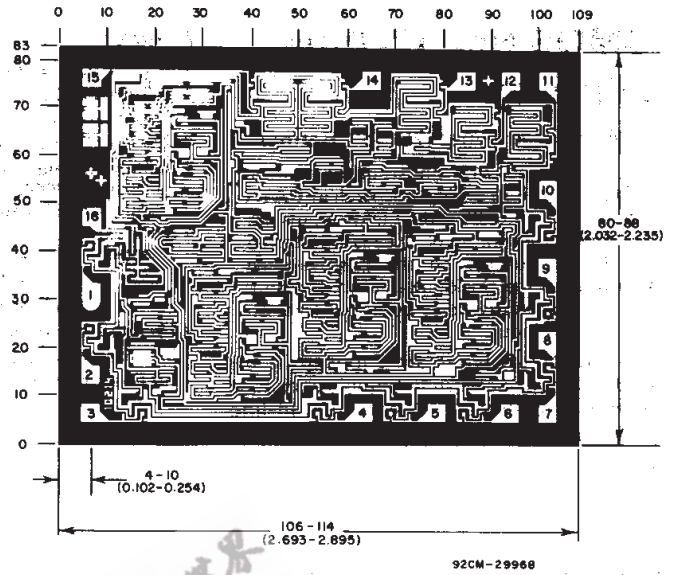

Fig. 17— Detail of flip-flops for CD40162B and CD40163B (synchronous clear).



Dimensions and pad layout for CD40160BH. Dimensions and pad layout for CD40161BH, CD40162BH, and CD40163BH are identical.

Dimensions in parentheses are in millimeters and are derived from the basic inch dimensions as indicated. Grid graduations are in mils (10^{-3} inch).

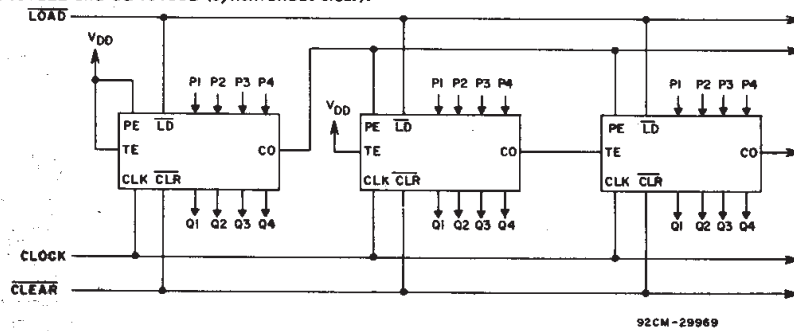

Fig. 18— Cascaded counter packages in the parallel-clocked mode.

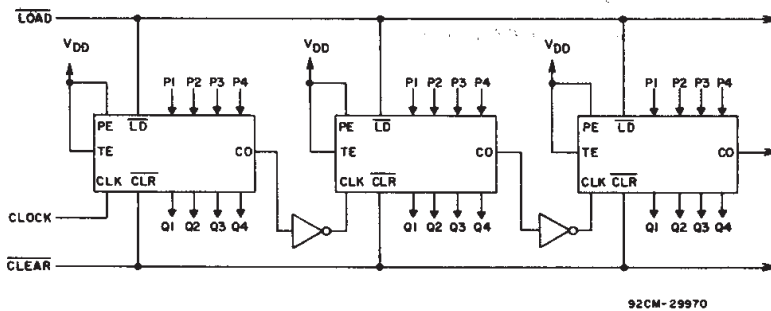

Fig. 19— Cascaded counter packages in the ripple-clocked mode.

3
COMMERCIAL CMOS

IMPORTANT NOTICE

Texas Instruments and its subsidiaries (TI) reserve the right to make changes to their products or to discontinue any product or service without notice, and advise customers to obtain the latest version of relevant information to verify, before placing orders, that information being relied on is current and complete. All products are sold subject to the terms and conditions of sale supplied at the time of order acknowledgement, including those pertaining to warranty, patent infringement, and limitation of liability.

TI warrants performance of its semiconductor products to the specifications applicable at the time of sale in accordance with TI's standard warranty. Testing and other quality control techniques are utilized to the extent TI deems necessary to support this warranty. Specific testing of all parameters of each device is not necessarily performed, except those mandated by government requirements.

CERTAIN APPLICATIONS USING SEMICONDUCTOR PRODUCTS MAY INVOLVE POTENTIAL RISKS OF DEATH, PERSONAL INJURY, OR SEVERE PROPERTY OR ENVIRONMENTAL DAMAGE ("CRITICAL APPLICATIONS"). TI SEMICONDUCTOR PRODUCTS ARE NOT DESIGNED, AUTHORIZED, OR WARRANTED TO BE SUITABLE FOR USE IN LIFE-SUPPORT DEVICES OR SYSTEMS OR OTHER CRITICAL APPLICATIONS. INCLUSION OF TI PRODUCTS IN SUCH APPLICATIONS IS UNDERSTOOD TO BE FULLY AT THE CUSTOMER'S RISK.

In order to minimize risks associated with the customer's applications, adequate design and operating safeguards must be provided by the customer to minimize inherent or procedural hazards.

TI assumes no liability for applications assistance or customer product design. TI does not warrant or represent that any license, either express or implied, is granted under any patent right, copyright, mask work right, or other intellectual property right of TI covering or relating to any combination, machine, or process in which such semiconductor products or services might be or are used. TI's publication of information regarding any third party's products or services does not constitute TI's approval, warranty or endorsement thereof.