

## 4-BIT MAGNITUDE COMPARATOR

- QUIESCENT CURRENT SPECIFIED TO 20V FOR HCC DEVICE
- STANDARD B-SERIES OUTPUT DRIVE
- EXPANSION TO 8-16V...4 N BITS BY CASCADING UNITS
- MEDIUM SPEED OPERATION : COMPARES TWO 4-BIT WORDS IN 250ns (typ.) AT 10V
- INPUT CURRENT OF 100nA AT 18V AND 25°C FOR HCC DEVICE
- 100% TESTED FOR QUIESCENT CURRENT
- MEETS ALL REQUIREMENTS OF JEDEC TENTATIVE STANDARD N° 13A, "STANDARD SPECIFICATIONS FOR DESCRIPTION OF "B" SERIES CMOS DEVICES"

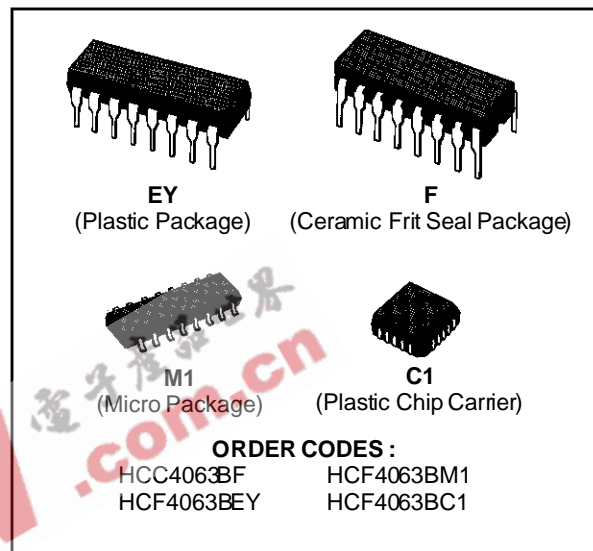

### DESCRIPTION

The **HCC4063B** (extended temperature range) and **HCF4063B** (intermediate temperature range) are available in 16-lead dual in-line plastic or ceramic package and plastic micro package. The **HCC/HCF4063B** is a low-power 4-bit magnitude comparator designed for use in computer and logic applications that require the comparison of two 4-bit words. This logic circuit determines whether one 4-bit word (Binary or BCD) is "less than", "equal to" or "greater than" a second 4-bit word. The **HCC/HCF4063B** has eight comparing inputs (A3, B3, through A0, B0), three outputs (A < B, A = B, A > B) and three cascading inputs (A < B, A = B, A > B) that permit systems designers to expand the comparator function to 8, 12, 16...4 N bits. When a single **HCC/HCF4063B** is used, the cascading inputs are connected as follows :

(A < B) = low, (A = B) = high, (A > B) = low.

For words longer than 4 bits, **HCC/HCF4063B** devices may be cascaded by connecting the outputs of the less-significant comparator to the corresponding cascading inputs of the more-significant comparator. Cascading inputs (A < B, A = B, and A > B) on the least significant comparator are connected to a low, a high, and a low level, respectively.

### PIN CONNECTIONS

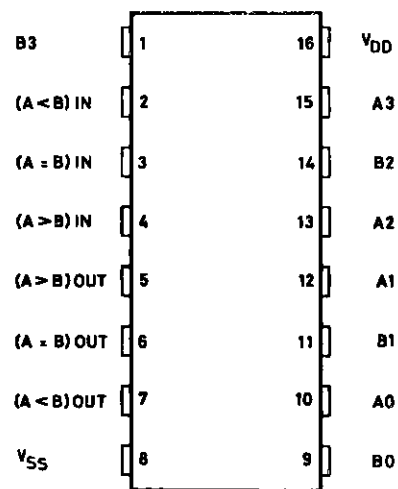

S-1488/1

## HCC/HCF4063B

### FUNCTIONAL DIAGRAM

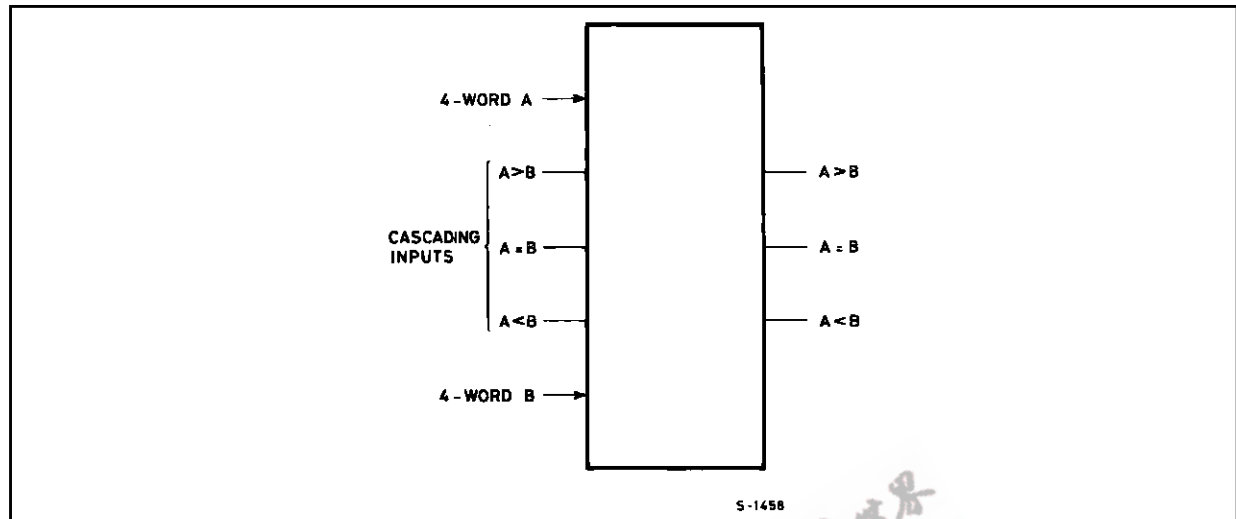

### ABSOLUTE MAXIMUM RATINGS

Symbol	Parameter	Value	Unit
$V_{DD}^*$	Supply Voltage : <b>HCC</b> Types <b>HCF</b> Types	- 0.5 to + 20	V
		- 0.5 to + 18	V
$V_i$	Input Voltage	- 0.5 to $V_{DD} + 0.5$	V
$I_I$	DC Input Current (any one input)	$\pm 10$	mA
$P_{tot}$	Total Power Dissipation (per package) Dissipation per Output Transistor for $T_{op}$ = Full Package-temperature Range	200	mW
		100	mW
$T_{op}$	Operating Temperature : <b>HCC</b> Types <b>HCF</b> Types	- 55 to + 125	°C
		- 40 to + 85	°C
$T_{stg}$	Storage Temperature	- 65 to + 150	°C

Stresses above those listed under "Absolute Maximum Ratings" may cause permanent damage to the device. This is a stress rating only and functional operation of the device at these or any other conditions above those indicated in the operational sections of this specification is not implied. Exposure to absolute maximum rating conditions for external periods may affect device reliability.  
\* All voltage values are referred to  $V_{SS}$  pin voltage.

### RECOMMENDED OPERATING CONDITIONS

Symbol	Parameter	Value	Unit
$V_{DD}$	Supply Voltage : <b>HCC</b> Types <b>HCF</b> Types	3 to 18	V
		3 to 15	V
$V_I$	Input Voltage	0 to $V_{DD}$	V
$T_{op}$	Operating Temperature : <b>HCC</b> Types <b>HCF</b> Types	- 55 to + 125	°C
		- 40 to + 85	°C

LOGIC DIAGRAM

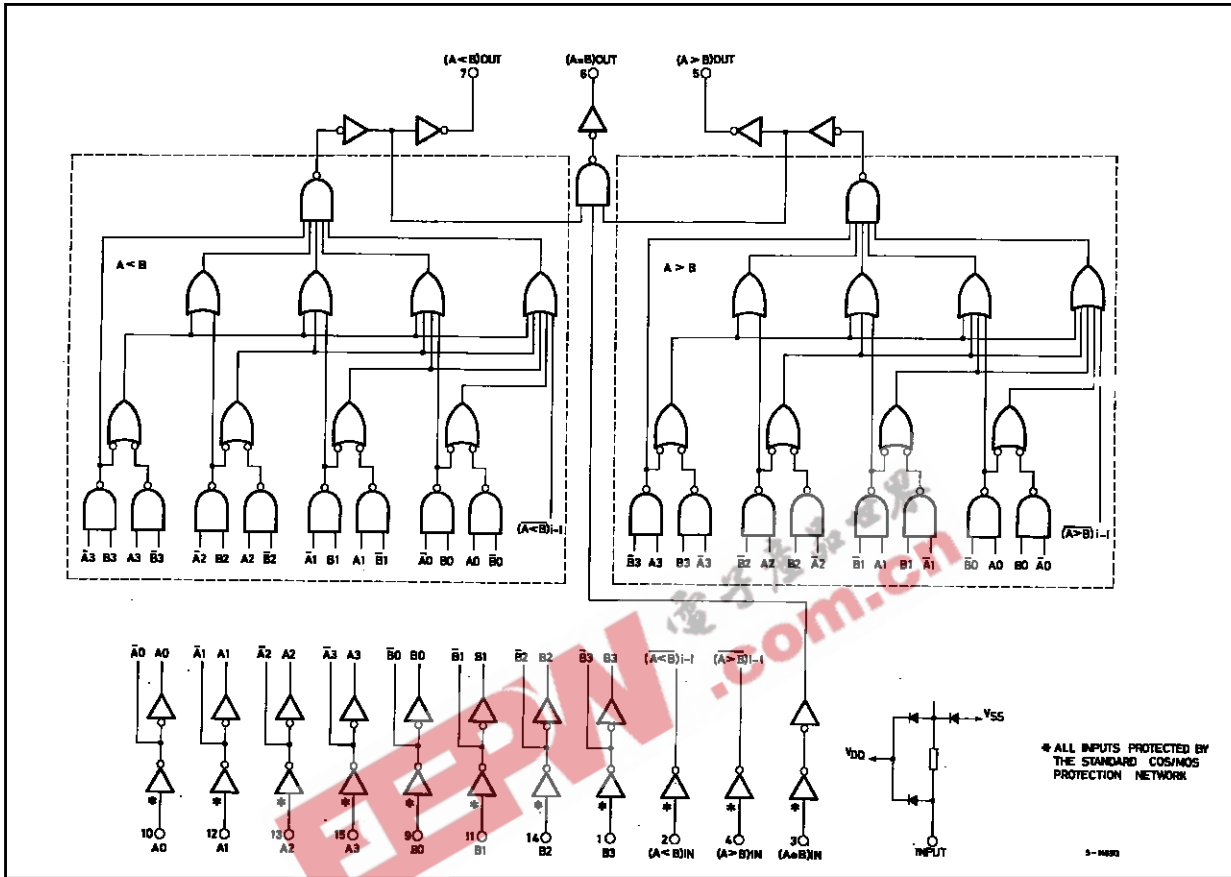

TRUTH TABLE

Inputs				Outputs					
Comparing				Cascading			A < B	A = B	A > B
A3, B3	A2, B2	A1, B1	A0, B0	A < B	A = B	A > B	A < B	A = B	A > B
A3 > B3	X	X	X	X	X	X	0	0	1
A3 = B3	A2 > B2	X	X	X	X	X	0	0	1
A3 = B3	A2 = B2	A1 > B1	X	X	X	X	0	0	1
A3 = B3	A2 = B2	A1 = B1	A0 > B0	X	X	X	0	0	1
A3 = B3	A2 = B2	A1 = B1	A0 = B0	0	0	1	0	0	1
A3 = B3	A2 = B2	A1 = B1	A0 = B0	0	1	0	0	1	0
A3 = B3	A2 = B2	A1 = B1	A0 = B0	1	0	0	1	0	0
A3 = B3	A2 = B2	A1 = B1	A0 < B0	X	X	X	1	0	0
A3 = B3	A2 = B2	A1 < B1	X	X	X	X	1	0	0
A3 = B3	A2 < B2	X	X	X	X	X	1	0	0
A3 < B3	X	X	X	X	X	X	1	0	0

X = Don't care

1 = High state

0 = Low state.

## HCC/HCF4063B

### STATIC ELECTRICAL CHARACTERISTICS (over recommended operating conditions)

Symbol	Parameter		Test Conditions				Value						Unit	
			V <sub>I</sub> (V)	V <sub>O</sub> (V)	I <sub>O</sub>   ( $\mu$ A)	V <sub>DD</sub> (V)	T <sub>Low</sub> *		25°C			T <sub>High</sub> *		
							Min.	Max.	Min.	Typ.	Max.	Min.		Max.
I <sub>L</sub>	Quiescent Current	HCC Types	0/5			5		5		0.04	5		150	$\mu$ A
			0/10			10		10		0.04	10		300	
			0/15			15		20		0.04	20		600	
			0/20			20		100		0.08	100		3000	
		HCF Types	0/5			5		20		0.04	20		150	
			0/10			10		40		0.04	40		300	
			0/15			15		80		0.04	80		600	
V <sub>OH</sub>	Output High Voltage	0/5		< 1	5	4.95		4.95			4.95		V	
		0/10		< 1	10	9.95		9.95			9.95			
		0/15		< 1	15	14.95		14.95			14.95			
V <sub>OL</sub>	Output Low Voltage	5/0		< 1	5		0.05			0.05		0.05	V	
		10/0		< 1	10		0.05			0.05		0.05		
		15/0		< 1	15		0.05			0.05		0.05		
V <sub>IH</sub>	Input High Voltage		0.5/4.5	< 1	5	3.5		3.5			3.5		V	
			1/9	< 1	10	7		7			7			
			1.5/13.5	< 1	15	11		11			11			
V <sub>IL</sub>	Input Low Voltage		4.5/0.5	< 1	5		1.5			1.5		1.5	V	
			9/1	< 1	10		3			3		3		
			13.5/1.5	< 1	15		4			4		4		
I <sub>OH</sub>	Output Drive Current	HCC Types	0/5	2.5		5	-2		-1.6	-3.2		-1.15	mA	
			0/5	4.6		5	-0.64		-0.51	-1		-0.36		
			0/10	9.5		10	-1.6		-1.3	-2.6		-0.9		
			0/15	13.5		15	-4.2		-3.4	-6.8		-2.4		
		HCF Types	0/5	2.5		5	-1.53		-1.36	-3.2		-1.1		
			0/5	4.6		5	-0.52		-0.44	-1		-0.36		
			0/10	9.5		10	-1.3		-1.1	-2.6		-0.9		
			0/15	13.5		15	-3.6		-3.0	-6.8		-2.4		
I <sub>OL</sub>	Output Sink Current	HCC Types	0/5	0.4		5	0.64		0.51	1		0.36	mA	
			0/10	0.5		10	1.6		1.3	2.6		0.9		
			0/15	1.5		15	4.2		3.4	6.8		2.4		
		HCF Types	0/5	0.4		5	0.52		0.44	1		0.36		
			0/10	0.5		10	1.3		1.1	2.6		0.9		
			0/15	1.5		15	3.6		3.0	6.8		2.4		
I <sub>IH</sub> , I <sub>IL</sub>	Input leakage Current	HCC Types	0/18	Any Input	18		$\pm 0.1$		$\pm 10^{-5}$	$\pm 0.1$		$\pm 1$	$\mu$ A	
		HCF Types	0/15		15		$\pm 0.3$		$\pm 10^{-5}$	$\pm 0.3$		$\pm 1$		
C <sub>I</sub>	Input Capacitance		Any Input						5	7.5			pF	

\* T<sub>Low</sub> = -55°C for HCC device : -40°C for HCF device.

\* T<sub>High</sub> = +125°C for HCC device : +85°C for HCF device.

The Noise Margin for both "1" and "0" level is : 1V min. with V<sub>DD</sub> = 5V, 2V min. with V<sub>DD</sub> = 10V, 2.5V min. with V<sub>DD</sub> = 15V.

**DYNAMIC ELECTRICAL CHARACTERISTICS** ( $T_{amb} = 25^{\circ}\text{C}$ ,  $C_L = 50\text{pF}$ ,  $R_L = 200\text{k}\Omega$ , typical temperature coefficient for all  $V_{DD}$  values is  $0.3\%/^{\circ}\text{C}$ , all input rise and fall times = 20ns)

Symbol	Parameter	Test Conditions		Value			Unit
			$V_{DD}$ (V)	Min.	Typ.	Max.	
$t_{PLH}$ , $t_{PHL}$	Propagation Delay Time	Comparing Inputs to Outputs	5		625	1250	ns
			10		250	500	
			15		175	350	
		Cascading Inputs to Outputs	5		500	1000	
			10		200	400	
			15		140	280	
$t_{TLH}$ , $t_{THL}$	Transition Time		5		100	200	ns
			10		50	100	
			15		40	80	

Minimum Output High (source) Current Characteristics.

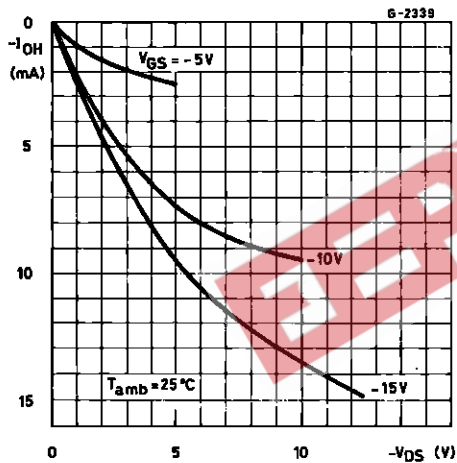

Minimum Output Low (sink) Current Characteristics.

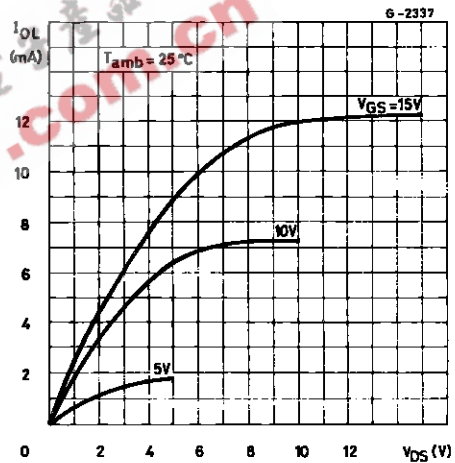

Typical Output High (source) Current Characteristics.

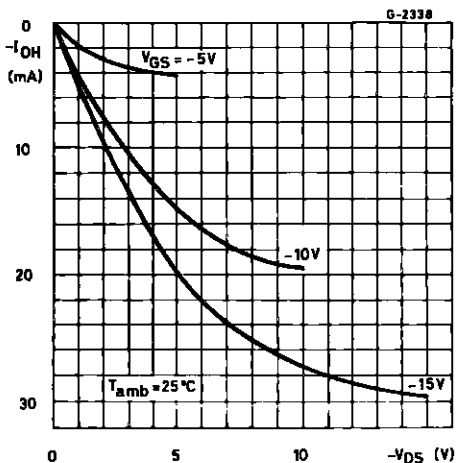

Typical Output Low (sink) Current Characteristics.

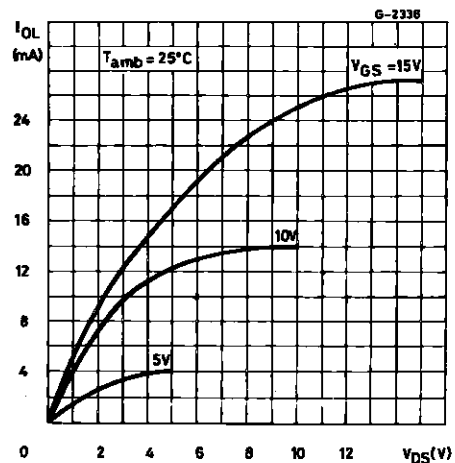

# HCC/HCF4063B

Typical Propagation Delay Time vs.  $V_{DD}$ .

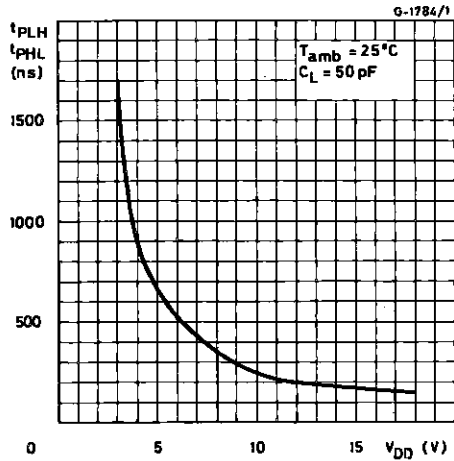

Typical Propagation Delay Time vs.  $C_L$ .

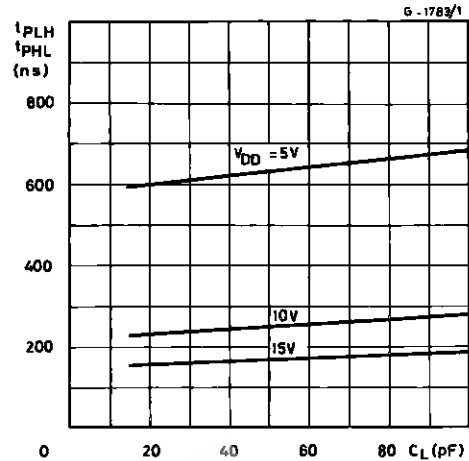

Typical Transition Time vs. Load Capacitance.

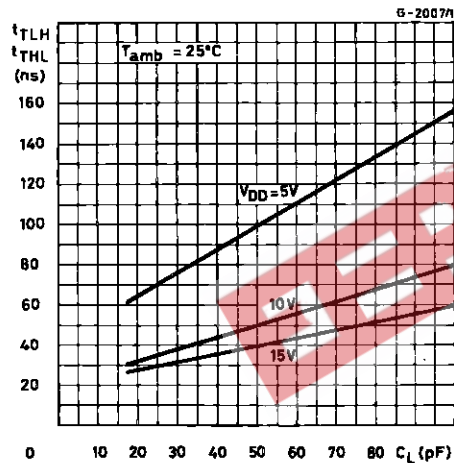

Typical Power Dissipation Characteristics.

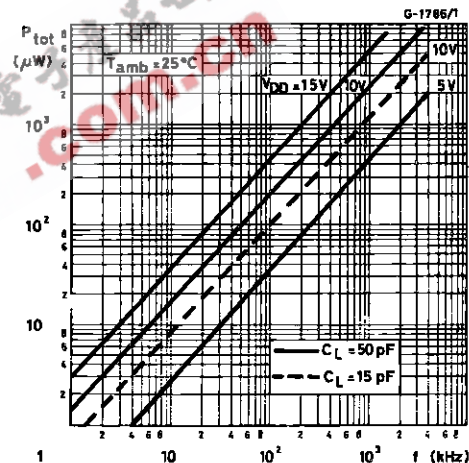

Dynamic Power Dissipation.

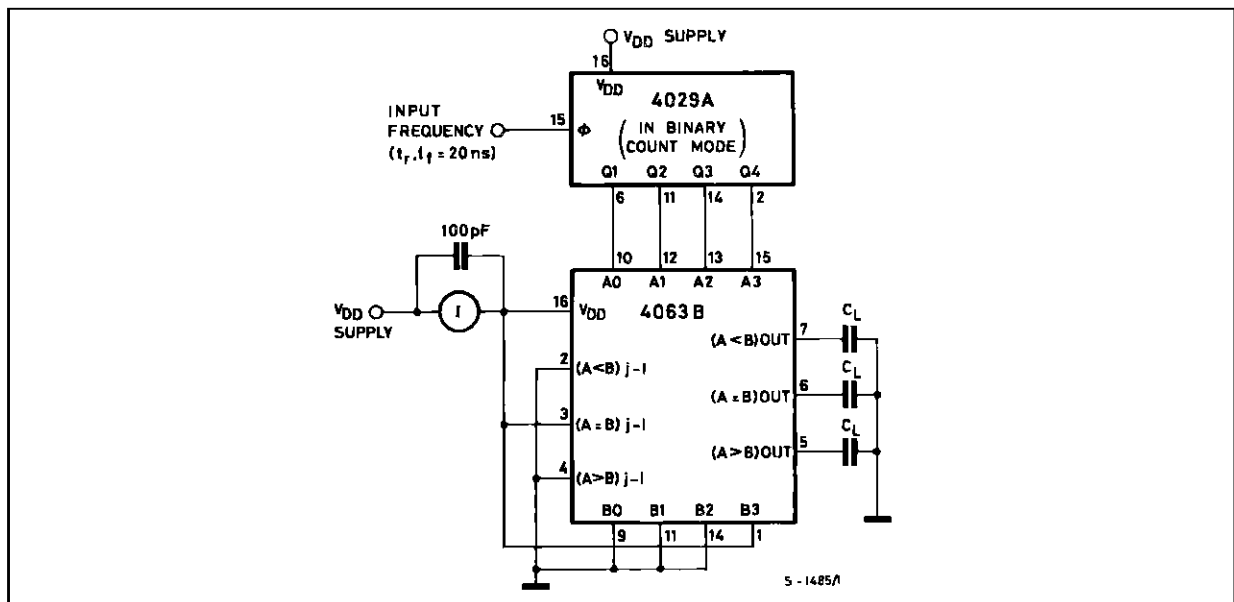

**TYPICAL APPLICATION**

**TYPICAL SPEED CHARACTERISTICS OF A 12-BIT COMPARATOR**

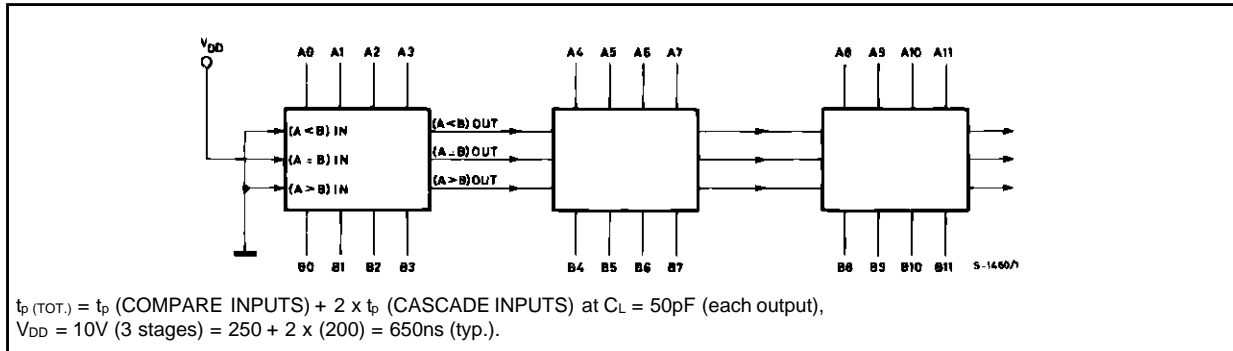

**TEST CIRCUITS**

**Quiescent Device Current.**

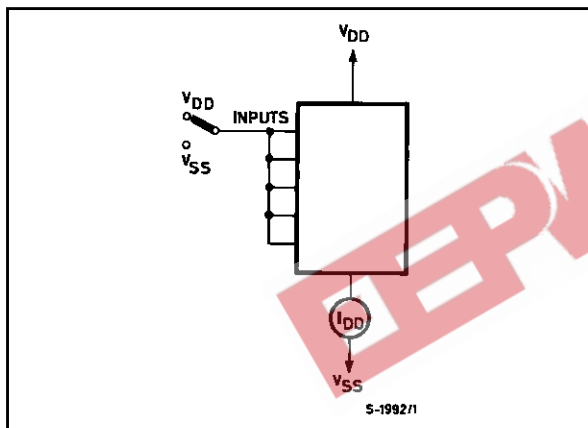

**Noise Immunity.**

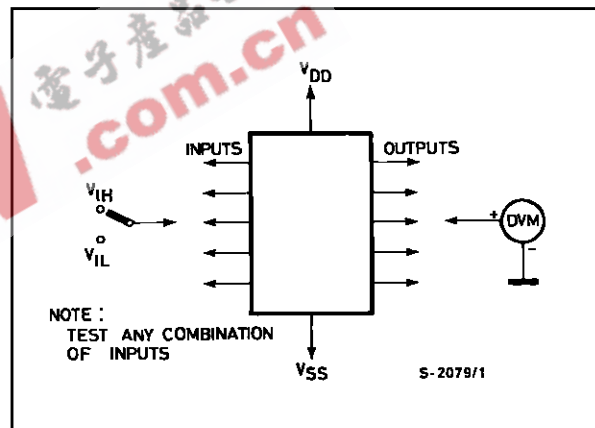

**Input Leakage Current.**

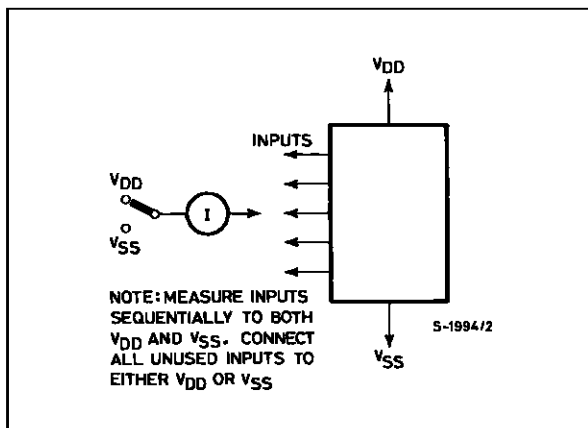

HCC/HCF4063B

**Plastic DIP16 (0.25) MECHANICAL DATA**

DIM.	mm			inch		
	MIN.	TYP.	MAX.	MIN.	TYP.	MAX.
a1	0.51			0.020		
B	0.77		1.65	0.030		0.065
b		0.5			0.020	
b1		0.25			0.010	
D			20			0.787
E		8.5			0.335	
e		2.54			0.100	
e3		17.78			0.700	
F			7.1			0.280
I			5.1			0.201
L		3.3			0.130	
Z			1.27			0.050

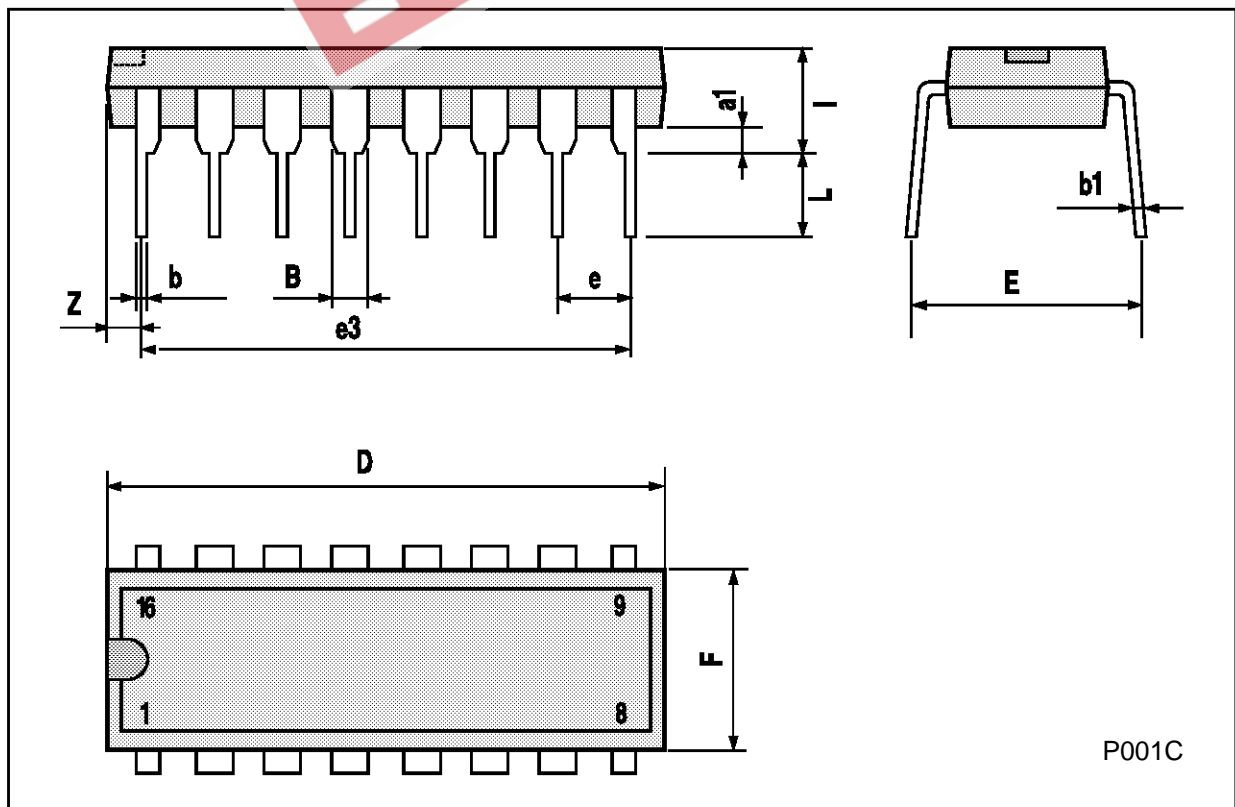

P001C



## Ceramic DIP16/1 MECHANICAL DATA

DIM.	mm			inch		
	MIN.	TYP.	MAX.	MIN.	TYP.	MAX.
A			20			0.787
B			7			0.276
D		3.3			0.130	
E	0.38			0.015		
e3		17.78			0.700	
F	2.29		2.79	0.090		0.110
G	0.4		0.55	0.016		0.022
H	1.17		1.52	0.046		0.060
L	0.22		0.31	0.009		0.012
M	0.51		1.27	0.020		0.050
N			10.3			0.406
P	7.8		8.05	0.307		0.317
Q			5.08			0.200

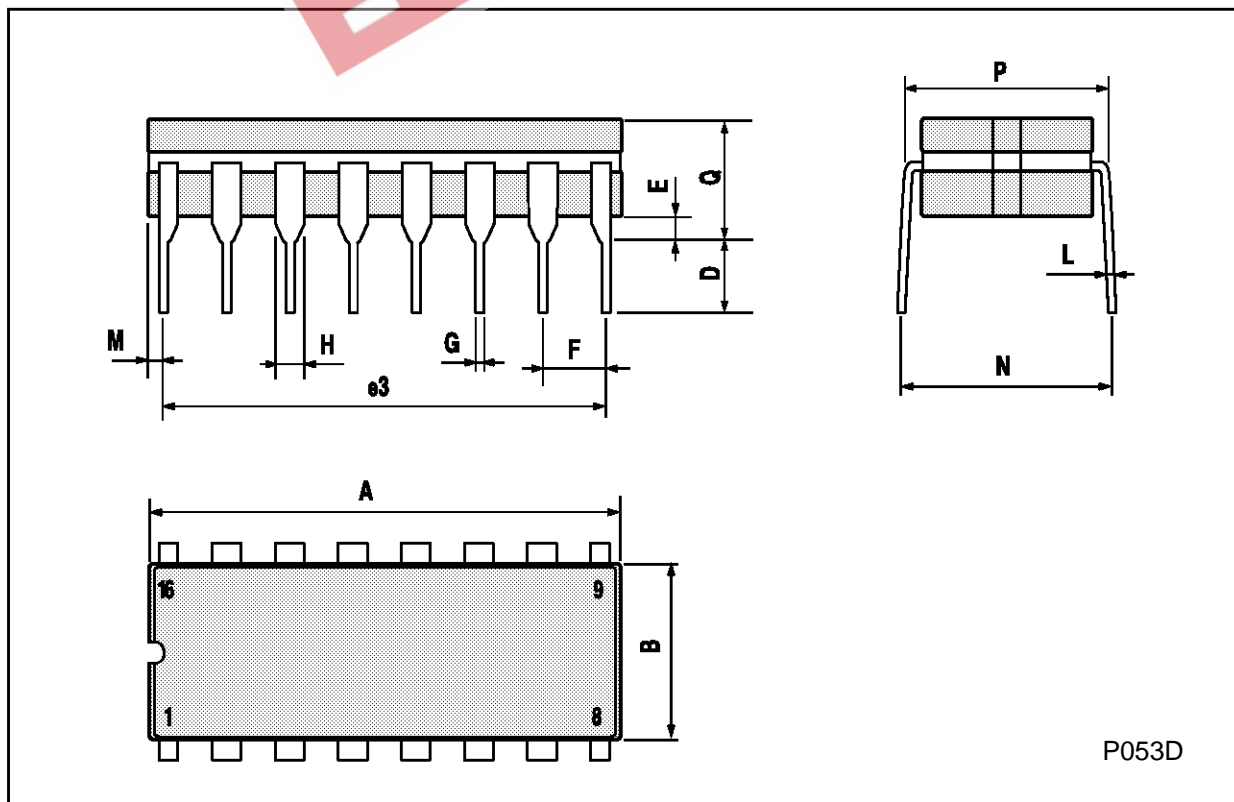

**SO16 (Narrow) MECHANICAL DATA**

DIM.	mm			inch		
	MIN.	TYP.	MAX.	MIN.	TYP.	MAX.
A			1.75			0.068
a1	0.1		0.2	0.004		0.007
a2			1.65			0.064
b	0.35		0.46	0.013		0.018
b1	0.19		0.25	0.007		0.010
C		0.5			0.019	
c1	45° (typ.)					
D	9.8		10	0.385		0.393
E	5.8		6.2	0.228		0.244
e		1.27			0.050	
e3		8.89			0.350	
F	3.8		4.0	0.149		0.157
G	4.6		5.3	0.181		0.208
L	0.5		1.27	0.019		0.050
M			0.62			0.024
S	8° (max.)					

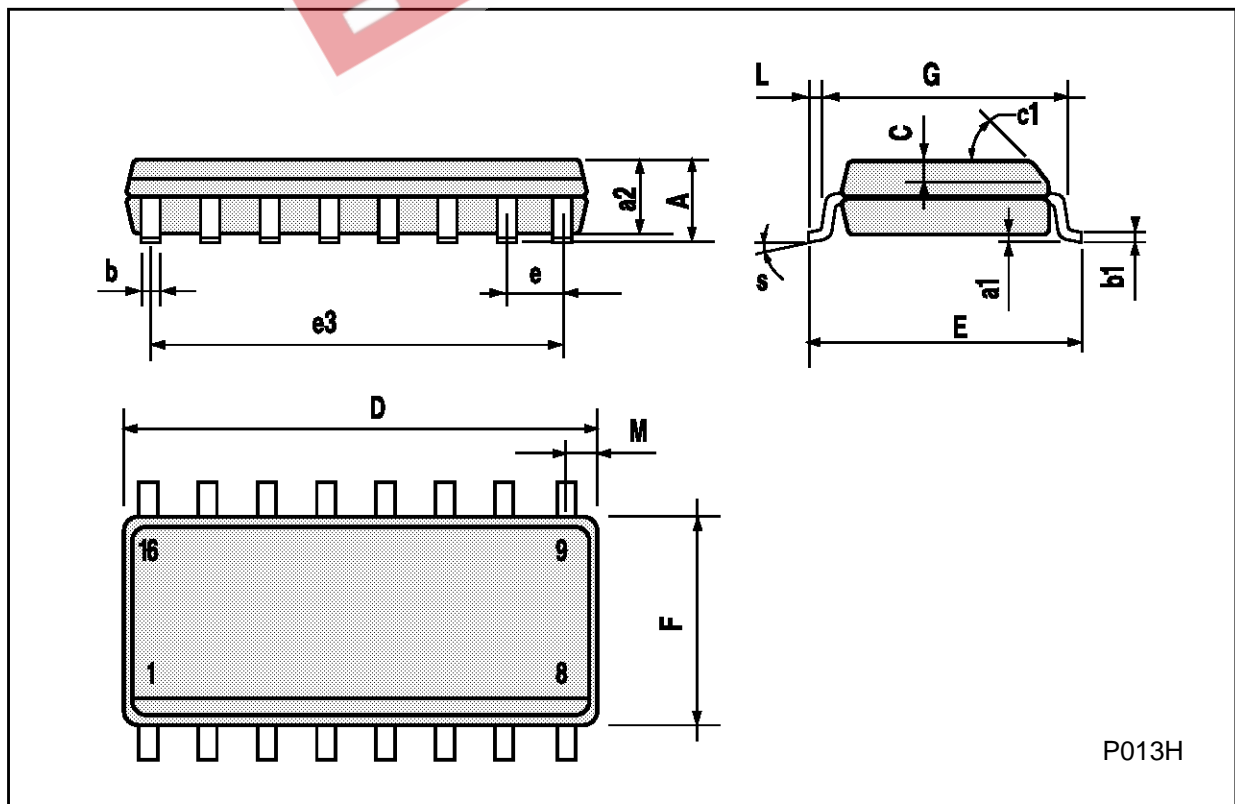

## PLCC20 MECHANICAL DATA

DIM.	mm			inch		
	MIN.	TYP.	MAX.	MIN.	TYP.	MAX.
A	9.78		10.03	0.385		0.395
B	8.89		9.04	0.350		0.356
D	4.2		4.57	0.165		0.180
d1		2.54			0.100	
d2		0.56			0.022	
E	7.37		8.38	0.290		0.330
e		1.27			0.050	
e3		5.08			0.200	
F		0.38			0.015	
G			0.101			0.004
M		1.27			0.050	
M1		1.14			0.045	

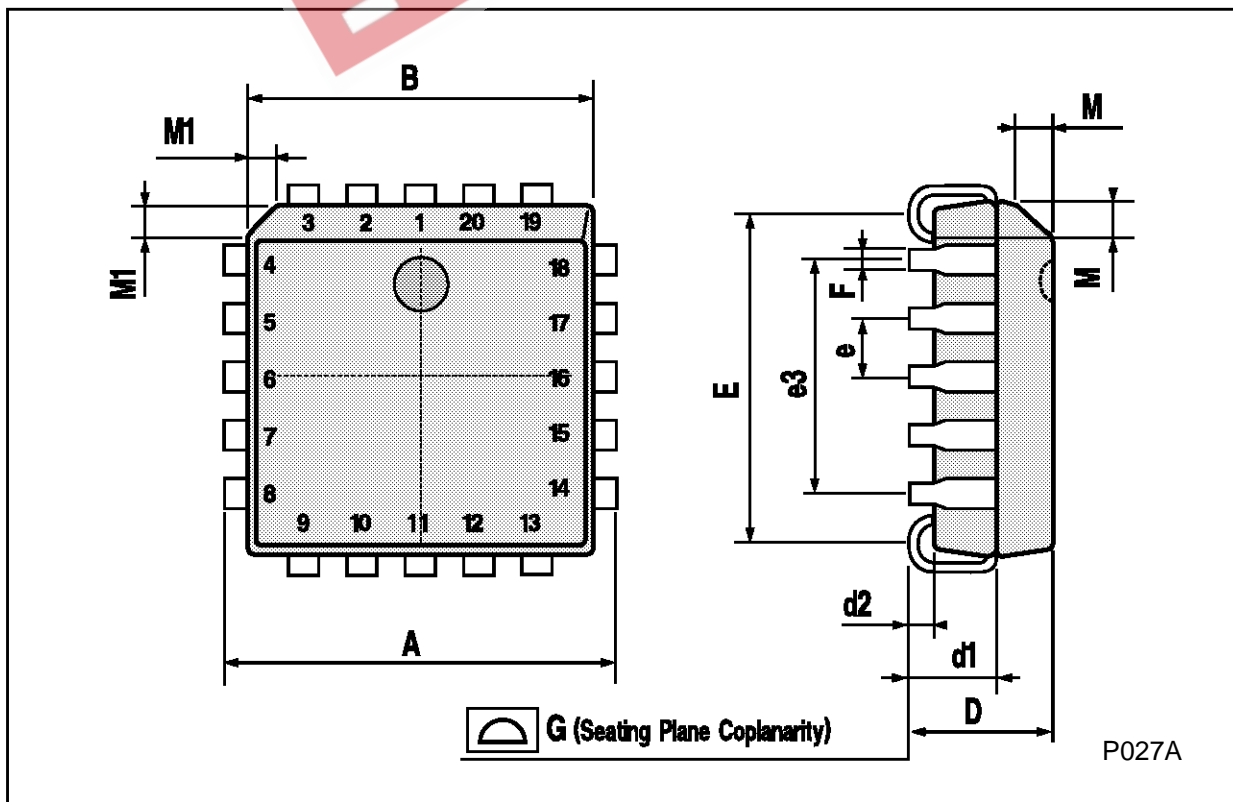

EEPW 电子產品世界  
.com.cn

Information furnished is believed to be accurate and reliable. However, SGS-THOMSON Microelectronics assumes no responsibility for the consequences of use of such information nor for any infringement of patents or other rights of third parties which may result from its use. No license is granted by implication or otherwise under any patent or patent rights of SGS-THOMSON Microelectronics. Specifications mentioned in this publication are subject to change without notice. This publication supersedes and replaces all information previously supplied. SGS-THOMSON Microelectronics products are not authorized for use as critical components in life support devices or systems without express written approval of SGS-THOMSON Microelectronics.

© 1994 SGS-THOMSON Microelectronics - All Rights Reserved

SGS-THOMSON Microelectronics GROUP OF COMPANIES  
Australia - Brazil - France - Germany - Hong Kong - Italy - Japan - Korea - Malaysia - Malta - Morocco - The Netherlands -  
Singapore - Spain - Sweden - Switzerland - Taiwan - Thailand - United Kingdom - U.S.A