

# F100136

## 4-Stage Counter/Shift Register

### General Description

The F100136 operates as either a modulo-16 up/down counter or as a 4-bit bidirectional shift register. Three Select ( $S_n$ ) inputs determine the mode of operation, as shown in the Function Select table. Two Count Enable ( $\overline{CEP}$ ,  $\overline{CET}$ ) inputs are provided for ease of cascading in multistage counters. One Count Enable ( $\overline{CET}$ ) input also doubles as a Serial Data ( $D_0$ ) Input for shift-up operation. For shift-down operation,  $D_3$  is the Serial Data input. In counting operations the Terminal Count ( $\overline{TC}$ ) output goes LOW when the counter reaches 15 in the count/up mode or 0 (zero) in the count/down mode. In the shift modes, the  $\overline{TC}$  output repeats the  $Q_3$  output. The dual nature of this  $\overline{TC}/Q_3$  output and the  $D_0/\overline{CET}$  input means that one interconnection from one stage to the next higher stage serves as the link for

multistage counting or shift-up operation. The individual Preset ( $P_n$ ) inputs are used to enter data in parallel or to preset the counter in programmable counter applications. A HIGH signal on the Master Reset ( $\overline{MR}$ ) input overrides all other inputs and asynchronously clears the flip-flops. In addition, a synchronous clear is provided, as well as a complement function which synchronously inverts the contents of the flip-flops. All inputs have 50 k $\Omega$  pull-down resistors.

Refer to the F100336 datasheet for:

- PCC packaging
- Lower power
- Military versions
- Extended voltage specs (-4.2V to -5.7V)

**Ordering Code:** See Section 8

### Logic Symbol

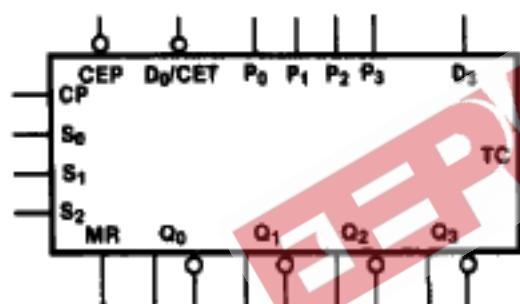

TL/F/9855-3

Pin Names	Description
CP	Clock Pulse Input
$\overline{CEP}$	Count Enable Parallel Input (Active LOW)
$D_0/\overline{CET}$	Serial Data Input/Count Enable
$P_0-P_3$	Trickle Input (Active LOW)
$S_0-S_2$	Select Inputs
$\overline{MR}$	Master Reset Input
$P_0-P_3$	Preset Inputs
$D_3$	Serial Data Input
$\overline{TC}$	Terminal Count Output
$Q_0-Q_3$	Data Outputs
$\overline{Q_0}-\overline{Q_3}$	Complementary Data Outputs

### Connection Diagrams

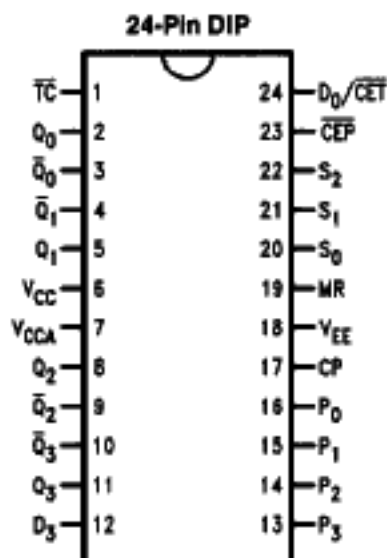

TL/F/9855-1

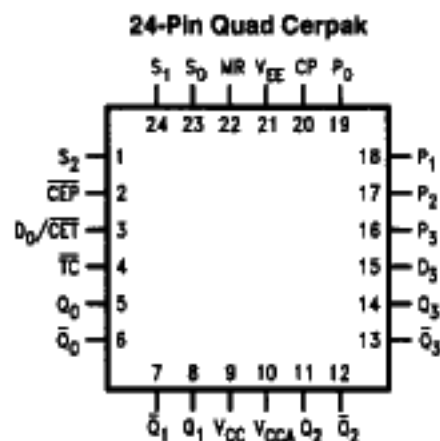

TL/F/9855-2

# Logic Diagram

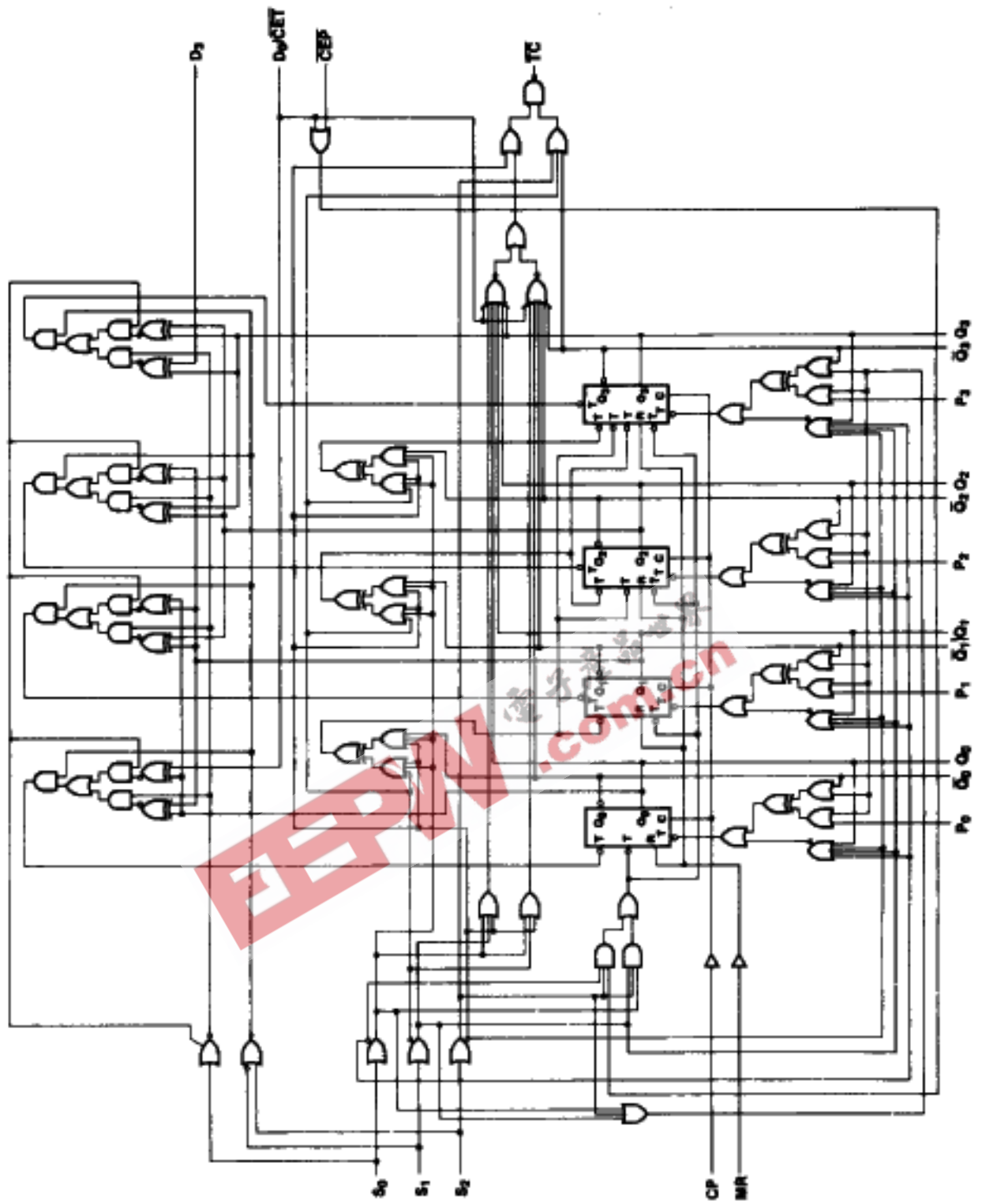

Function Select Table

S <sub>2</sub>	S <sub>1</sub>	S <sub>0</sub>	Function
L	L	L	Parallel Load
L	L	H	Complement
L	H	L	Shift Left
L	H	H	Shift Right
H	L	L	Count Down
H	L	H	Clear
H	H	L	Count Up
H	H	H	Hold

Truth Table

Q<sub>0</sub> = LSB

Inputs								Outputs					Mode
MR	S <sub>2</sub>	S <sub>1</sub>	S <sub>0</sub>	CEP	D <sub>0</sub> /CET	D <sub>3</sub>	CP	Q <sub>3</sub>	Q <sub>2</sub>	Q <sub>1</sub>	Q <sub>0</sub>	TC	Mode
L	L	L	L	X	X	X	↗	P <sub>3</sub>	P <sub>2</sub>	P <sub>1</sub>	P <sub>0</sub>	L	Preset (Parallel Load)
L	L	L	H	X	X	X	↗	$\bar{Q}_3$	$\bar{Q}_2$	$\bar{Q}_1$	$\bar{Q}_0$	L	Invert
L	L	H	L	X	X	X	↗	D <sub>3</sub>	Q <sub>3</sub>	Q <sub>2</sub>	D <sub>1</sub>	D <sub>3</sub>	Shift Left
L	L	H	H	X	X	X	↗	Q <sub>2</sub>	Q <sub>1</sub>	Q <sub>0</sub>	D <sub>0</sub>	Q <sub>3</sub> *	Shift Right
L	H	L	L	L	L	X	↗	(Q <sub>0-3</sub> ) minus 1				⊖	Count Down
L	H	L	L	H	L	X	X	Q <sub>3</sub>	Q <sub>2</sub>	Q <sub>1</sub>	Q <sub>0</sub>	⊖	Count Down with CEP not active
L	H	L	L	X	H	X	X	Q <sub>3</sub>	Q <sub>2</sub>	Q <sub>1</sub>	Q <sub>0</sub>	H	Count Down with CET not active
L	H	L	H	X	X	X	↗	L	L	L	L	H	Clear
L	H	H	L	L	L	X	↗	(Q <sub>0-3</sub> ) plus 1				⊕	Count Up
L	H	H	L	H	L	X	X	Q <sub>3</sub>	Q <sub>2</sub>	Q <sub>1</sub>	Q <sub>0</sub>	⊕	Count Up with CEP not active
L	H	H	L	X	H	X	X	Q <sub>3</sub>	Q <sub>2</sub>	Q <sub>1</sub>	Q <sub>0</sub>	H	Count Up with CET not active
L	H	H	H	X	X	X	X	Q <sub>3</sub>	Q <sub>2</sub>	Q <sub>1</sub>	Q <sub>0</sub>	H	Hold
H	L	L	L	X	X	X	X	L	L	L	L	L	Asynchronous Master Reset
H	L	L	H	X	X	X	X	L	L	L	L	L	
H	L	H	L	X	X	X	X	L	L	L	L	L	
H	L	H	H	X	X	X	X	L	L	L	L	L	
H	H	L	L	X	L	X	X	L	L	L	L	L	
H	H	L	L	X	H	X	X	L	L	L	L	L	
H	H	L	H	X	X	X	X	L	L	L	L	L	
H	H	H	L	X	X	X	X	L	L	L	L	L	
H	H	H	H	X	X	X	X	L	L	L	L	L	
H	H	H	H	X	X	X	X	L	L	L	L	L	

- ⊖ = L if Q<sub>0</sub>-Q<sub>3</sub> = LLLL  
 H if Q<sub>0</sub>-Q<sub>3</sub> ≠ LLLL
- ⊕ = L if Q<sub>0</sub>-Q<sub>3</sub> = HHHH  
 H if Q<sub>0</sub>-Q<sub>3</sub> ≠ HHHH
- H = HIGH Voltage Level  
 L = LOW Voltage Level  
 X = Don't Care  
 ↗ = LOW-to-HIGH Transition

\*Before the clock, TC is Q<sub>3</sub>  
 After the clock, TC is Q<sub>2</sub>

**Absolute Maximum Ratings**

Above which the useful life may be impaired. (Note 1)

If Military/Aerospace specified devices are required, please contact the National Semiconductor Sales Office/Distributors for availability and specifications.

Storage Temperature                    -65°C to +150°C  
Maximum Junction Temperature (T<sub>j</sub>)       +150°C

Case Temperature under Bias (T<sub>C</sub>)           0°C to +85°C  
V<sub>EE</sub> Pin Potential to Ground Pin           -7.0V to +0.5V  
Input Voltage (DC)                            V<sub>EE</sub> to +0.5V  
Output Current (DC Output HIGH)         -50 mA  
Operating Range (Note 2)                   -5.7V to -4.2V

**DC Electrical Characteristics**V<sub>EE</sub> = -4.5V, V<sub>CC</sub> = V<sub>CCA</sub> = GND, T<sub>C</sub> = 0°C to +85°C (Note 3)

Symbol	Parameter	Min	Typ	Max	Units	Conditions (Note 4)	
V <sub>OH</sub>	Output HIGH Voltage	-1025	-955	-880	mV	V <sub>IN</sub> = V <sub>IH</sub> (Max) or V <sub>IL</sub> (Min)	Loading with 50Ω to -2.0V
V <sub>OL</sub>	Output LOW Voltage	-1810	-1705	-1620			
V <sub>OHC</sub>	Output HIGH Voltage	-1035			mV	V <sub>IN</sub> = V <sub>IH</sub> (Min) or V <sub>IL</sub> (Max)	Loading with 50Ω to -2.0V
V <sub>OLC</sub>	Output LOW Voltage			-1610			
V <sub>IH</sub>	Input HIGH Voltage	-1165		-880	mV	Guaranteed HIGH Signal for All Inputs	
V <sub>IL</sub>	Input LOW Voltage	-1810		-1475	mV	Guaranteed LOW Signal for All Inputs	
I <sub>IL</sub>	Input LOW Current	0.50			μA	V <sub>IN</sub> = V <sub>IL</sub> (Min)	

**DC Electrical Characteristics**V<sub>EE</sub> = -4.2V, V<sub>CC</sub> = V<sub>CCA</sub> = GND, T<sub>C</sub> = 0°C to +85°C (Note 3)

Symbol	Parameter	Min	Typ	Max	Units	Conditions (Note 4)	
V <sub>OH</sub>	Output HIGH Voltage	-1020		-870	mV	V <sub>IN</sub> = V <sub>IH</sub> (Max) or V <sub>IL</sub> (Min)	Loading with 50Ω to -2.0V
V <sub>OL</sub>	Output LOW Voltage	-1810		-1605			
V <sub>OHC</sub>	Output HIGH Voltage	-1030			mV	V <sub>IN</sub> = V <sub>IH</sub> (Min) or V <sub>IL</sub> (Max)	Loading with 50Ω to -2.0V
V <sub>OLC</sub>	Output LOW Voltage			-1595			
V <sub>IH</sub>	Input HIGH Voltage	-1150		-870	mV	Guaranteed HIGH Signal for All Inputs	
V <sub>IL</sub>	Input LOW Voltage	-1810		-1475	mV	Guaranteed LOW Signal for All Inputs	
I <sub>IL</sub>	Input LOW Current	0.50			μA	V <sub>IN</sub> = V <sub>IL</sub> (Min)	

**DC Electrical Characteristics**V<sub>EE</sub> = -4.8V, V<sub>CC</sub> = V<sub>CCA</sub> = GND, T<sub>C</sub> = 0°C to +85°C (Note 3)

Symbol	Parameter	Min	Typ	Max	Units	Conditions (Note 4)	
V <sub>OH</sub>	Output HIGH Voltage	-1035		-880	mV	V <sub>IN</sub> = V <sub>IH</sub> (Max) or V <sub>IL</sub> (Min)	Loading with 50Ω to -2.0V
V <sub>OL</sub>	Output LOW Voltage	-1830		-1620			
V <sub>OHC</sub>	Output HIGH Voltage	-1045			mV	V <sub>IN</sub> = V <sub>IH</sub> (Min) or V <sub>IL</sub> (Max)	Loading with 50Ω to -2.0V
V <sub>OLC</sub>	Output LOW Voltage			-1610			
V <sub>IH</sub>	Input HIGH Voltage	-1165		-880	mV	Guaranteed HIGH Signal for All Inputs	
V <sub>IL</sub>	Input LOW Voltage	-1830		-1490	mV	Guaranteed LOW Signal for All Inputs	
I <sub>IL</sub>	Input LOW Current	0.50			μA	V <sub>IN</sub> = V <sub>IL</sub> (Min)	

**Note 1:** Absolute maximum ratings are those values beyond which the device may be damaged or have its useful life impaired. Functional operation under these conditions is not implied.

**Note 2:** Parametric values specified at -4.2V to -4.8V.

**Note 3:** The specified limits represent the "worst case" value for the parameter. Since these "worst case" values normally occur at the temperature extremes, additional noise immunity and guard banding can be achieved by decreasing the allowable system operating ranges.

**Note 4:** Conditions for testing shown in the tables are chosen to guarantee operation under "worst case" conditions.

**DC Electrical Characteristics** $V_{EE} = -4.2V$  to  $-4.8V$  unless otherwise specified,  $V_{CC} = V_{CCA} = GND$ ,  $T_C = 0^\circ C$  to  $+85^\circ C$ 

Symbol	Parameter	Min	Typ	Max	Units	Conditions
$I_{IH}$	Input HIGH Current					$V_{IN} = V_{IH}(\text{Max})$
	$P_n, S_n$			180	$\mu A$	
	$\overline{CEP}$			200		
	MR			240		
	$D_3$			280		
	CP			390		
$D_0/\overline{CET}$			530			
$I_{EE}$	Power Supply Current	-283	-195	-136	mA	Inputs Open

**Ceramic Dual-In-Line Package AC Characteristics** $V_{EE} = -4.2V$  to  $-4.8V$ ,  $V_{CC} = V_{CCA} = GND$ 

Symbol	Parameter	$T_C = 0^\circ C$		$T_C = +25^\circ C$		$T_C = +85^\circ C$		Units	Conditions
		Min	Max	Min	Max	Min	Max		
$f_{\text{shift}}$	Shift Frequency	250		250		250		MHz	Figures 2 and 3
$t_{PLH}$ $t_{PHL}$	Propagation Delay CP to $Q_n, \overline{Q}_n$	0.85	2.10	0.85	2.10	0.85	2.25	ns	Figures 1 and 3
$t_{PLH}$ $t_{PHL}$	Propagation Delay CP to $\overline{TC}$	1.90	4.80	1.90	4.60	1.90	5.20	ns	
$t_{PLH}$ $t_{PHL}$	Propagation Delay MR to $Q_n, \overline{Q}_n$	1.20	2.95	1.35	2.95	1.20	3.10	ns	Figures 1 and 4
$t_{PLH}$ $t_{PHL}$	Propagation Delay MR to $\overline{TC}$	2.20	4.80	2.20	4.80	2.20	5.30	ns	
$t_{PLH}$ $t_{PHL}$	Propagation Delay $D_0/\overline{CET}$ to $\overline{TC}$	1.40	3.20	1.40	3.20	1.40	3.50	ns	Figures 1 and 5
$t_{PLH}$ $t_{PHL}$	Propagation Delay $S_n$ to $\overline{TC}$	0.90	3.80	1.00	3.80	1.00	4.30	ns	
$t_{TLH}$ $t_{THL}$	Transition Time 20% to 80%, 80% to 20%	0.45	1.80	0.45	1.80	0.45	1.80	ns	Figures 1 and 3
$t_s$	Setup Time							ns	Figure 6
	$D_3$	1.20		1.20		1.20			
	$P_n$	1.70		1.70		1.70			
	$D_0/\overline{CET}, \overline{CEP}$	1.45		1.45		1.45			
	$S_n$	3.30		3.30		3.30			
$t_h$	Hold Time							ns	Figure 6
	$D_3$	0.20		0.20		0.20			
	$P_n$	0.10		0.10		0.10			
	$D_0/\overline{CET}, \overline{CEP}$	0.20		0.20		0.20			
	$S_n$	-0.90		-0.90		-0.90			
$t_{pw(H)}$	Pulse Width HIGH CP, MR	2.00		2.00		2.00		ns	Figures 3 and 4

**Cerpak AC Electrical Characteristics**  $V_{EE} = -4.2V$  to  $-4.8V$ ,  $V_{CC} = V_{CCA} = GND$ 

Symbol	Parameter	$T_C = 0^\circ C$		$T_C = +25^\circ C$		$T_C = +85^\circ C$		Units	Conditions
		Min	Max	Min	Max	Min	Max		
$f_{shift}$	Shift Frequency	250		250		250		MHz	Figures 2 and 3
$t_{PLH}$ $t_{PHL}$	Propagation Delay CP to $Q_n, \bar{Q}_n$	0.85	1.90	0.85	1.90	0.85	2.05	ns	Figures 1 and 3
$t_{PLH}$ $t_{PHL}$	Propagation Delay CP to TC	1.90	4.60	1.90	4.40	1.90	5.00	ns	
$t_{PLH}$ $t_{PHL}$	Propagation Delay MR to $Q_n, \bar{Q}_n$	1.20	2.75	1.35	2.75	1.20	2.90	ns	Figures 1 and 4
$t_{PLH}$ $t_{PHL}$	Propagation Delay MR to TC	2.20	4.60	2.20	4.60	2.20	5.10	ns	
$t_{PLH}$ $t_{PHL}$	Propagation Delay $D_0/CET$ to TC	1.40	3.00	1.40	3.00	1.40	3.30	ns	Figures 1 and 5
$t_{PLH}$ $t_{PHL}$	Propagation Delay $S_n$ to TC	0.90	3.60	1.00	3.60	1.00	4.10	ns	
$t_{TLH}$ $t_{THL}$	Transition Time 20% to 80%, 80% to 20%	0.45	1.70	0.45	1.70	0.45	1.70	ns	Figures 1 and 3
$t_s$	Setup Time $D_3$ $P_n$ $D_0/CET, CEP$ $S_n$ MR (Release Time)	1.10 1.60 1.35 3.20 2.50		1.10 1.60 1.35 3.20 2.50		1.10 1.60 1.35 3.20 2.50		ns	Figure 6
$t_h$	Hold Time $D_3$ $P_n$ $D_0/CET, CEP$ $S_n$	0.10 0 0.10 -1.00		0.10 0 0.10 -1.00		0.10 0 0.10 -1.00		ns	Figure 6
$t_{pw(H)}$	Pulse Width HIGH CP, MR	2.00		2.00		2.00		ns	Figures 3 and 4

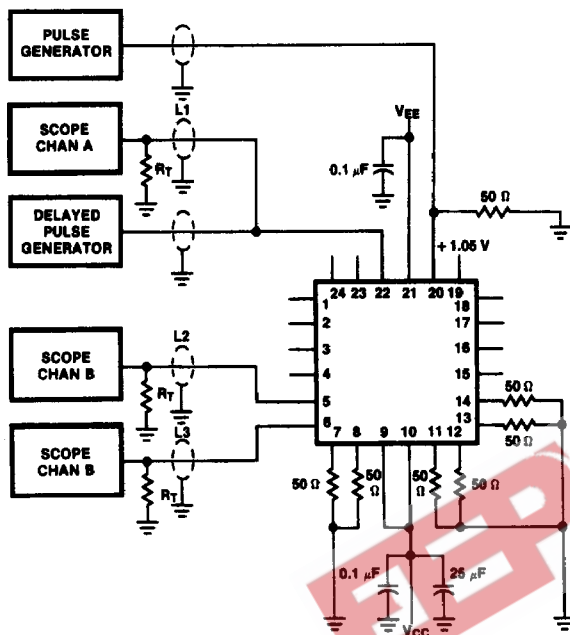

**Notes:**  
 $V_{CC}, V_{CCA} = +2V, V_{EE} = -2.5V$   
 $L1, L2$  and  $L3 =$  equal length  $50\Omega$  impedance lines  
 $R_T = 50\Omega$  terminator internal to scope  
 Decoupling  $0.1 \mu F$  from GND to  $V_{CC}$  and  $V_{EE}$   
 All unused outputs are loaded with  $50\Omega$  to GND  
 $C_L =$  Fixture and stray capacitance  $\leq 3 pF$   
 Pin numbers shown are for flatpak;  
 for DIP see logic symbol

FIGURE 1. AC Test Circuit

TL/F/9855-6

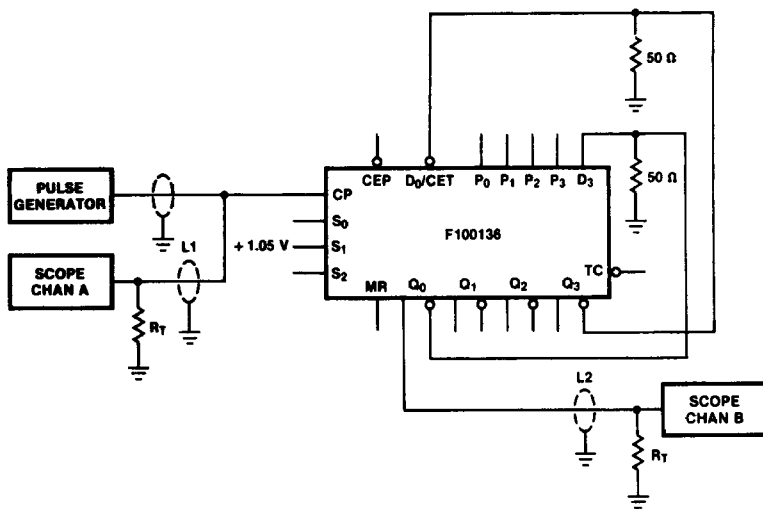

FIGURE 2. Shift Frequency Test Circuit (Shift Left)

TL/F/9855-7

**Notes:**  
 For shift right mode,  $+1.05V$  is applied at  $S_0$ .  
 The feedback path from output to input should be as short as possible.

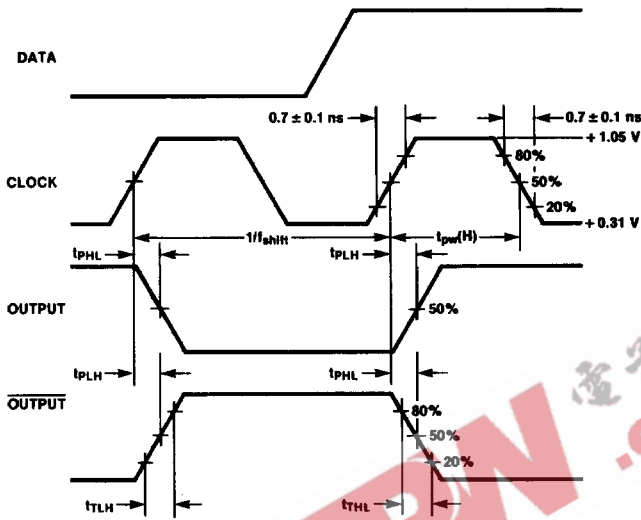

FIGURE 3. Propagation Delay (Clock) and Transition Times

TL/F/9855-8

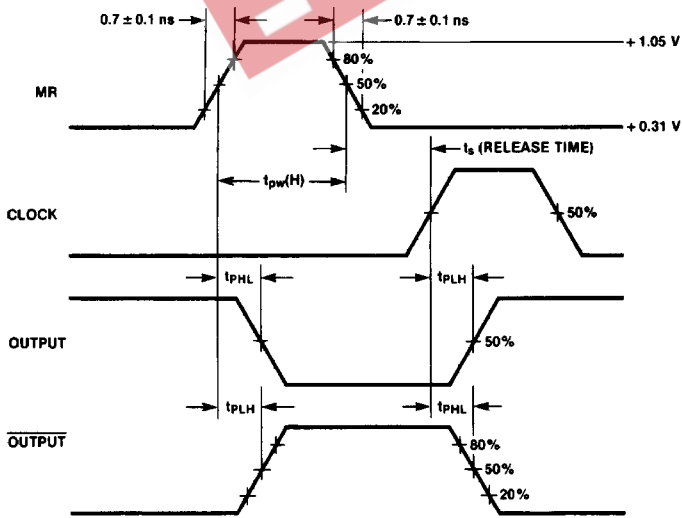

FIGURE 4. Propagation Delay (Reset)

TL/F/9855-9



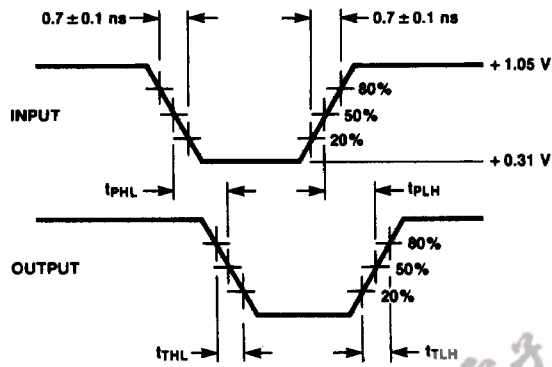
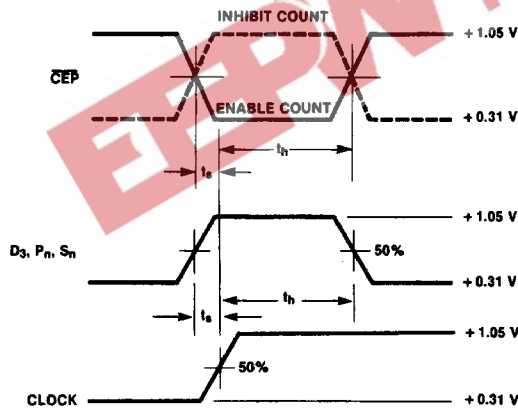

FIGURE 5. Propagation Delay (Serial Data, Selects)

TL/F/9855-10



TL/F/9855-11

**Notes:**

$t_s$  is the minimum time before the transition of the clock that information must be present at the data input.  
 $t_h$  is the minimum time after the transition of the clock that information must remain unchanged at the data input.

FIGURE 6. Setup and Hold Time

Applications

3-Stage Divider, Preset Count Down Mode  
PRESET N

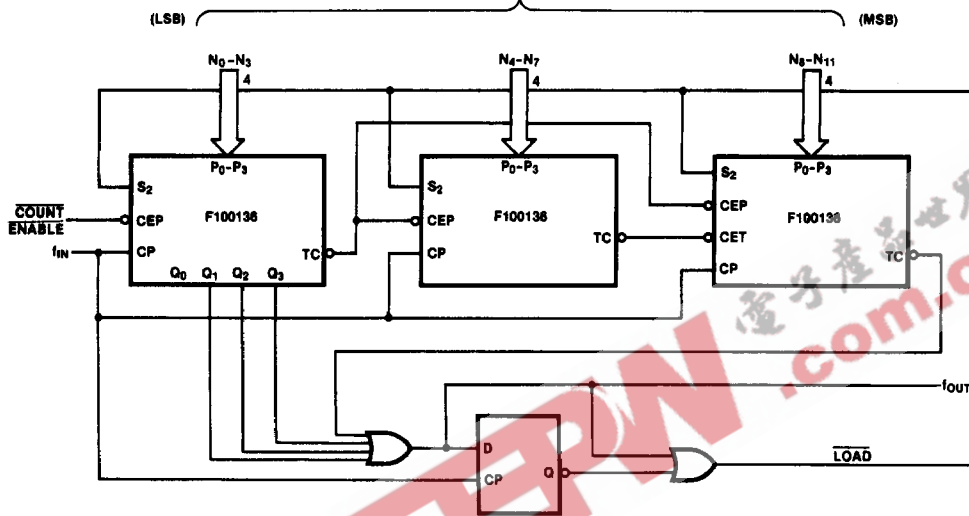

Note: If  $S_0 = S_1 = S_2 = \text{LOW}$ , then  $T_C = \text{LOW}$

TL/F/9855-12

Slow Expansion Scheme

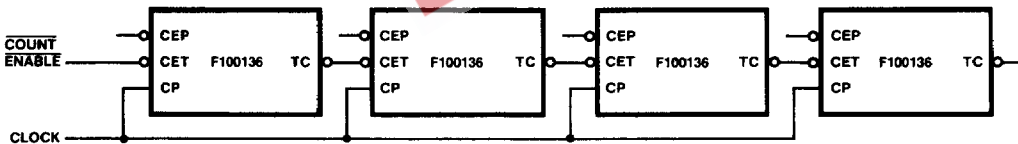

TL/F/9855-13

Fast Expansion Scheme

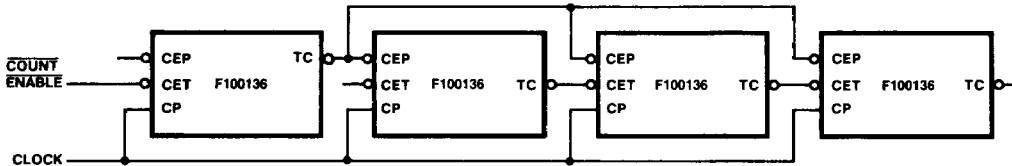

TL/F/9855-15