

4 BIT D TYPE REGISTERS

- THREE STATE OUTPUTS
- INPUT DISABLE WITHOUT GATING THE CLOCK
- GATED OUTPUT CONTROL LINES FOR ENABLING OR DISABLING THE OUTPUTS
- QUIESCENT CURRENT SPECIFIED TO 20V FOR HCC DEVICE
- 5V, 10V AND 15V PARAMETRIC RATINGS
- INPUT CURRENT OF 100nA AT 18V AND 25°C FOR HCC DEVICE
- 100% TESTED FOR QUIESCENT CURRENT
- MEETS ALL REQUIREMENTS OF JEDEC TENTATIVE STANDARD N. 13A, "STANDARD SPECIFICATIONS FOR DESCRIPTION OF B SERIES CMOS DEVICES"

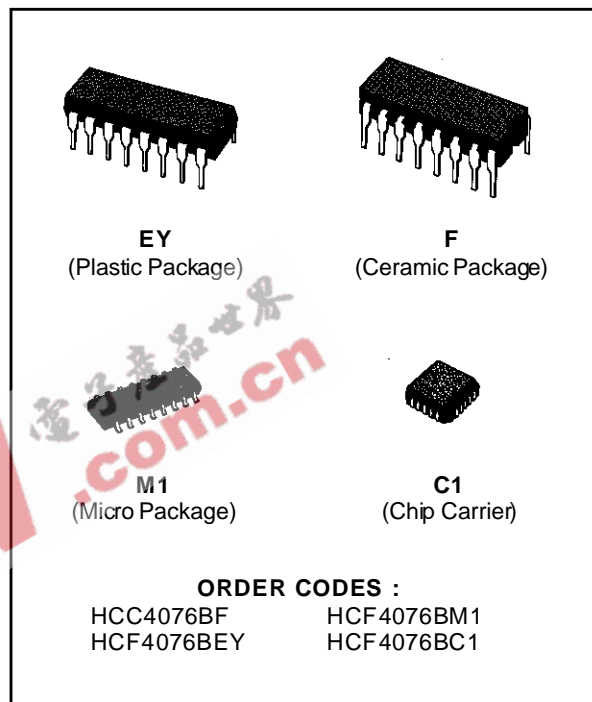

DESCRIPTION

The **HCC4076B** (extended temperature range) and **HCF4076B** (intermediate temperature range) are monolithic integrated circuit, available in 16 lead dual in line plastic or ceramic package and plastic micropackage.

The **HCC/HCF4076B** types are four-bit registers consisting of D-type flip-flops that feature three-state outputs. Data Disable inputs are provided to control the entry of data into the flip-flops. When both Data Disable inputs are low, data at the D inputs are loaded into their respective flip-flops on the next positive transition of the clock input. Output Disable inputs are also provided. When the Output Disable inputs are both low, the normal logic states of the four outputs are available to the load. The outputs are disabled independently of the clock by a high logic level at either Output Disable input, and present a high impedance.

PIN CONNECTIONS

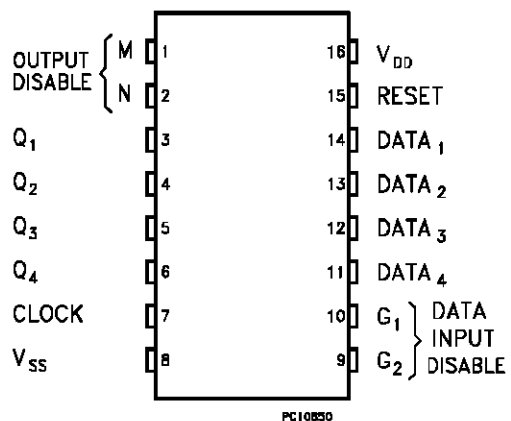

HCC/HCF4076B

FUNCTIONAL DIAGRAM

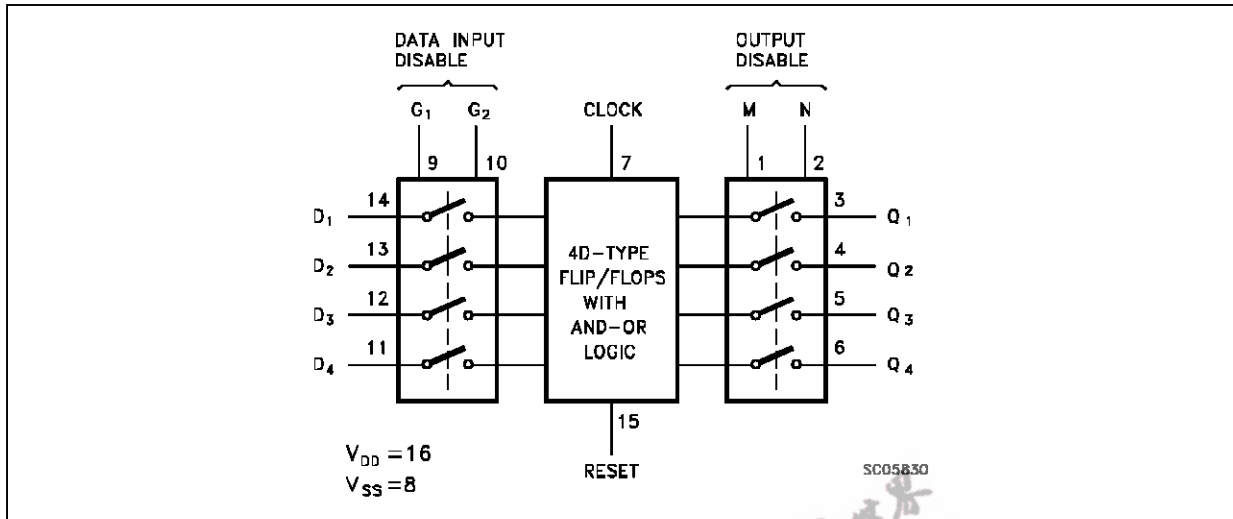

ABSOLUTE MAXIMUM RATING

Symbol	Parameter	Value	Unit
V _{DD} *	Supply Voltage: HCC Types HCF Types	-0.5 to +20 -0.5 to +18	V V
V _i	Input Voltage	-0.5 to V _{DD} + 0.5	V
I _i	DC Input Current (any one input)	± 10	mA
P _{tot}	Total Power Dissipation (per package) Dissipation per Output Transistor for T _{op} = Full Package Temperature Range	200 100	mW mW
T _{op}	Operating Temperature: HCC Types HCF Types	-55 to +125 -40 to +85	°C °C
T _{stg}	Storage Temperature	-65 to +150	°C

Stresses above those listed under "Absolute Maximum Ratings" may cause permanent damage to the device. This is a stress rating only and functional operation of the device at these or any other conditions above those indicated in the operational sections of this specification is not implied. Exposure to absolute maximum rating conditions for external periods may affect device reliability.

* All voltage values are referred to V_{SS} pin voltage.

RECOMMENDED OPERATING CONDITIONS

Symbol	Parameter	Value	Unit
V _{DD}	Supply Voltage: HCC Types HCF Types	3 to 18 3 to 15	V V
V _i	Input Voltage	0 to V _{DD}	V
T _{op}	Operating Temperature: HCC Types HCF Types	-55 to +125 -40 to +85	°C °C

LOGIC DIAGRAM

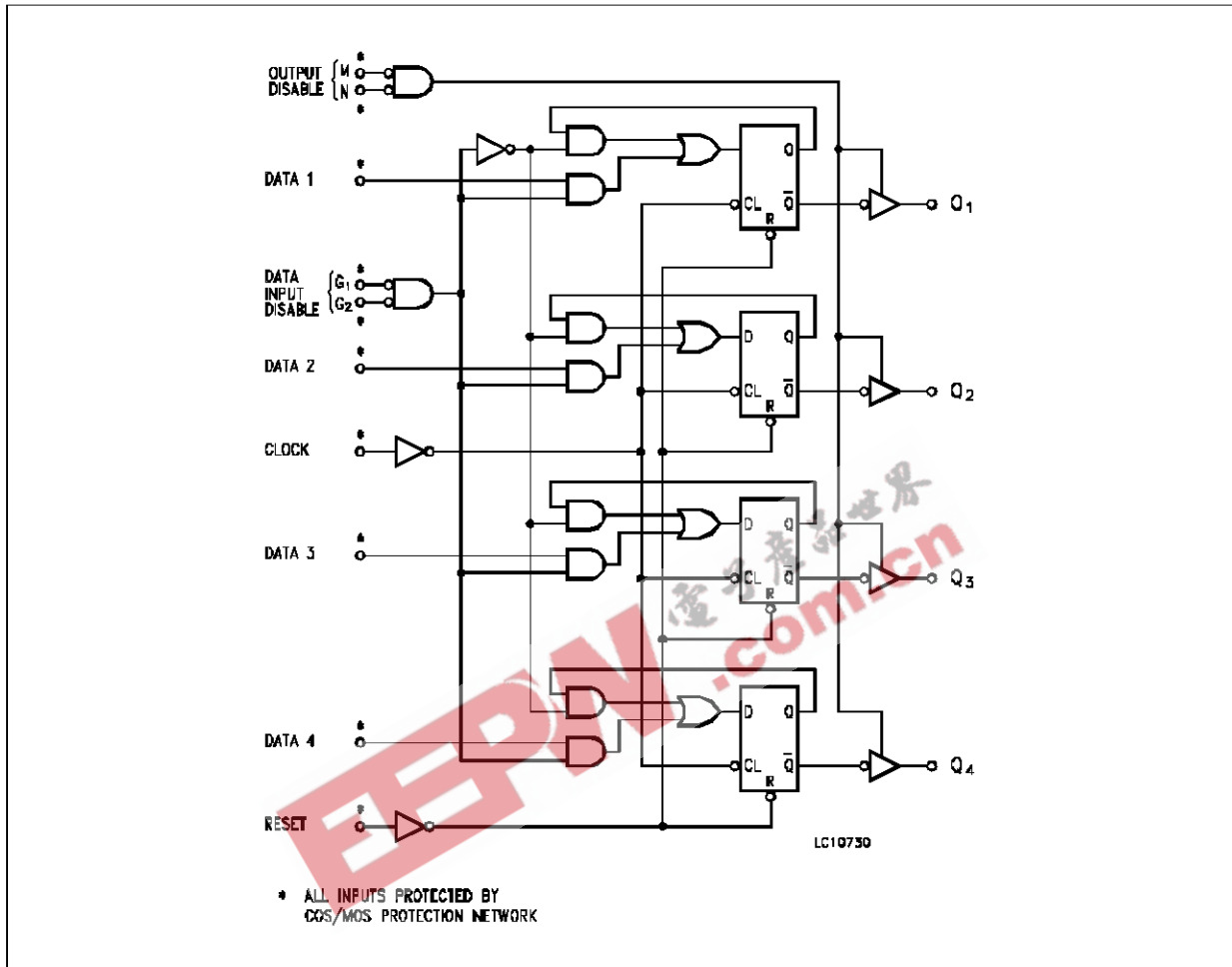

TRUTH TABLE

RESET	CLOCK	DATA INPUT DISABLE		DATA D	NEXT STATE OUTPUT G	
		G1	G2			
1	X	X	X	X	0	
0	0	X	X	X	Q	NC
0		1	X	X	Q	NC
0		X	1	X	Q	NC
0		0	0	1	1	
0		0	0	0	0	
0	1	X	X	X	Q	NC
0		X	X	X	Q	NC

When either Output Disable M or N is high, the outputs are disabled (high impedance state): however sequential operation of the flip-flop is not affected. 1 = High Level, 0 = Low Level, X = Don't Care, NC = No Change

HCC/HCF4076B

STATIC ELECTRICAL CHARACTERISTICS (over recommended operating conditions)

Symbol	Parameter		Test Conditions				Value						Unit	
			V _I (V)	V _O (V)	I _{oI} (μ A)	V _{DD} (V)	T _{LOW} *		25 °C			T _{HIGH} *		
							Min.	Max.	Min.	Typ.	Max.	Min.		Max.
I _L	Quiescent Current	HCC Types	0/5			5		5		0.04	5		150	μ A
			0/10			10		10		0.04	10		300	
			0/15			15		20		0.04	20		600	
			0/20			20		100		0.08	100		3000	
		HCF Types	0/5			5		20		0.04	20		150	
			0/10			10		40		0.04	40		300	
V _{OH}	Output High Voltage	0/5		< 1	5	4.95		4.95			4.95		V	
		0/10		< 1	10	9.95		9.95			9.95			
		0/15		< 1	15	14.95		14.95			14.95			
V _{OL}	Output Low Voltage	5/0		< 1	5		0.05			0.05		0.05	V	
		10/0		< 1	10		0.05			0.05		0.05		
		15/0		< 1	15		0.05			0.05		0.05		
V _{IH}	Input High Voltage		0.5/4.5	< 1	5	3.5		3.5			3.5		V	
			1/9	< 1	10	7		7			7			
V _{IL}	Input Low Voltage		1.5/13.5	< 1	15	11		11			11		V	
			4.5/0.5	< 1	5	1.5				1.5		1.5		
			9/1	< 1	10	3				3		3		
I _{OH}	Output Drive Current	HCC Types	0/5	2.5		5	-2		-1.6	-3.2		-1.15	mA	
			0/5	4.6		5	-0.64		-0.51	-1		-0.36		
			0/10	9.5		10	-1.6		-1.3	-2.6		-0.9		
			0/15	13.5		15	-4.2		-3.4	-6.8		-2.4		
		HCF Types	0/5	2.5		5	-1.53		-1.36	-3.2		-1.1		
			0/5	4.6		5	-0.52		-0.44	-1		-0.36		
I _{OL}	Output Sink Current	HCC Types	0/5	0.4		5	0.64		0.51	1		0.36	mA	
			0/10	0.5		10	1.6		1.3	2.6		0.9		
			0/15	1.5		15	4.2		3.4	6.8		2.4		
		HCF Types	0/5	0.4		5	0.61		0.44	1		0.36		
			0/10	0.5		10	1.		1.1	2.6		0.9		
			0/15	1.5		15	3.6		3.0	6.8		2.4		
I _{IH} , I _{IL}	Input Leakage Current	0/18	Any Input		18		± 0.1		$\pm 10^{-5}$	± 0.1		± 1	μ A	
		0/15			15		± 0.3		$\pm 10^{-5}$	± 0.3		± 1	μ A	
I _{OH} , I _{OL}	Input Leakage Current	HCC Types	0/18	0/18		18		± 0.4		$\pm 10^{-4}$	± 0.4		± 12	μ A
		HCF Types	0/15	0/15		15		± 1.0		$\pm 10^{-4}$	± 1.0		± 7.5	μ A
C _I	Input Capacitance		Any Input						5	7.5			pF	

* T_{LOW} = -55 °C for HCC device; -40 °C for HCF device.

* T_{HIGH} = +125 °C for HCC device; +85 °C for HCF device.

The Noise Margin for both "1" and "0" level is: 1V min. with V_{DD} = 5 V, 2 V min. with V_{DD} = 10 V, 2.5 V min. with V_{DD} = 15 V

DYNAMIC ELECTRICAL CHARACTERISTICS ($T_{amb} = 25\text{ }^{\circ}\text{C}$, $C_L = 50\text{ pF}$, $R_L = 200\text{ K}\Omega$, typical temperature coefficient for all V_{DD} values is $03\text{ }^{\circ}\text{C}$, all input rise and fall times = 20 ns)

Symbol	Parameter	Test Conditions	Value			Unit	
			V_{DD} (V)	Min.	Typ.		Max.
t_{PLH} t_{PHL}	Propagation Delay Time (Clock to Q Output)		5		300	600	ns
			10		125	250	
			15		90	180	
$t_{PHL(R)}$	Propagation Delay Time (Reset)		5		230	460	ns
			10		100	200	
			15		75	150	
$t_{P(1-H)}$ $t_{P(0-H)}$	3-State Output 1 or 0 to High Impedance	$R_L = 1\text{ K}\Omega$	5		150	300	ns
			10		75	150	
			15		60	120	
$t_{P(H-1)}$ $t_{P(L-1)}$	3-State High Impedance to 1 or 0 Output	$R_L = 1\text{ K}\Omega$	5		150	300	ns
			10		75	150	
			15		60	120	
t_w	Clock Pulse Width		5	200	100		ns
			10	100	50		
			15	80	40		
t_w	Reset Pulse Width		5	120	60		ns
			10	50	25		
			15	40	20		
t_{setup}	Data Setup Time		5	200	100		ns
			10	80	40		
			15	60	30		
t_{setup}	Data Input Disable Setup Time		5	180	90		ns
			10	100	50		
			15	70	35		
f_{max}	Maximum Clock Frequency		5	3	6		MHz
			10	6	12		
			15	8	16		
t_r, t_f	Clock Input Rise or Fall Time		5	15			μs
			10	5			
			15	5			

HCC/HCF4076B

Typical Output Low (sink) Current Characteristics

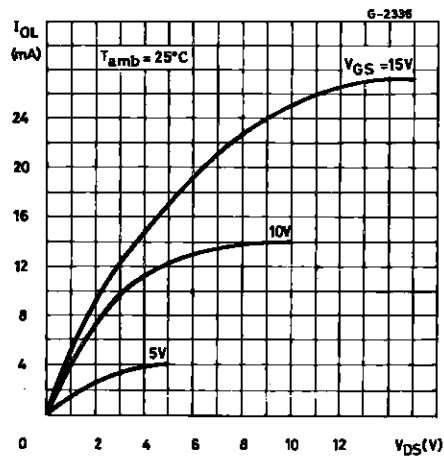

Minimum Output Low (sink) Current Characteristics

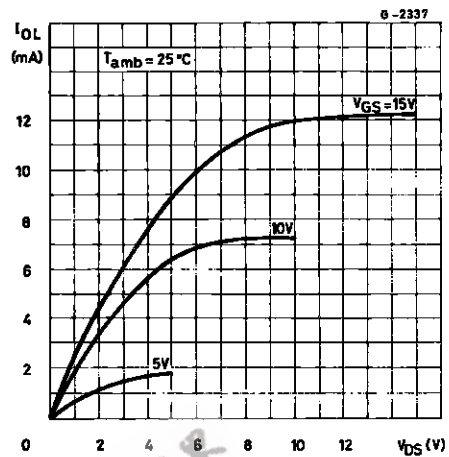

Typical Output High (source) Current Characteristics

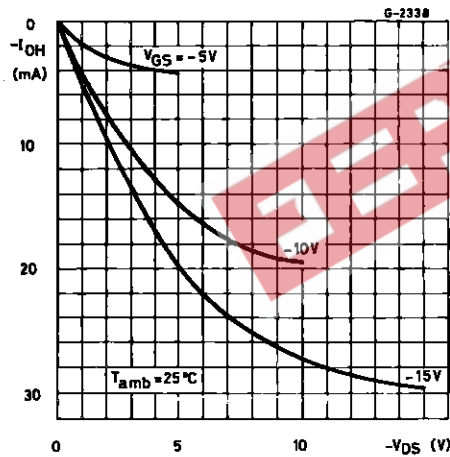

Minimum Output High (source) Current Characteristics

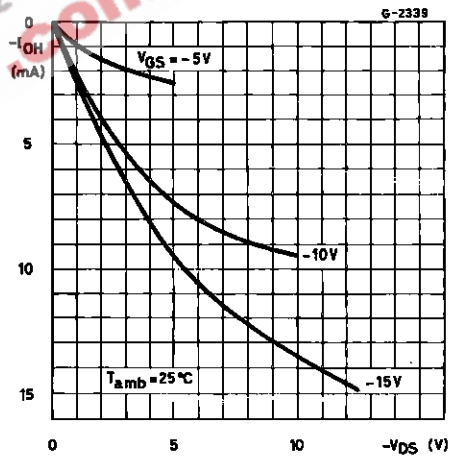

Typical Maximum Clock Input Frequency vs Supply Voltage

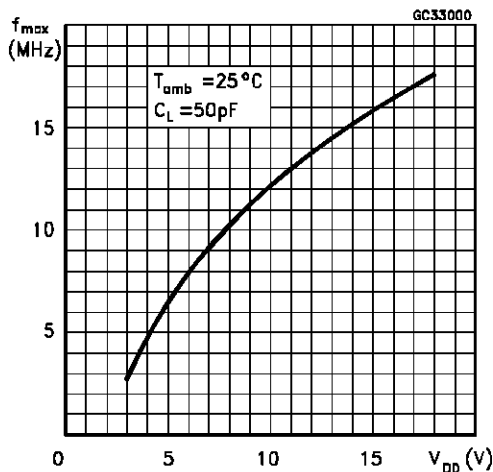

Typical Dynamic Power Dissipation vs Frequency

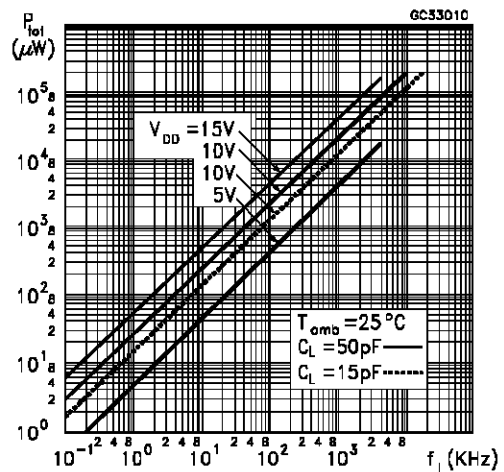

Typical Propagation Delay Time vs Capacitance

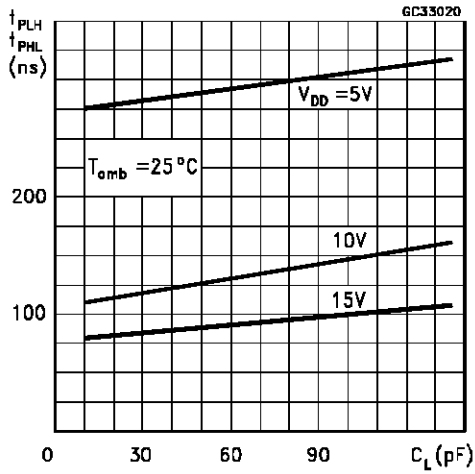

Typical Transition Time vs Load Capacitance

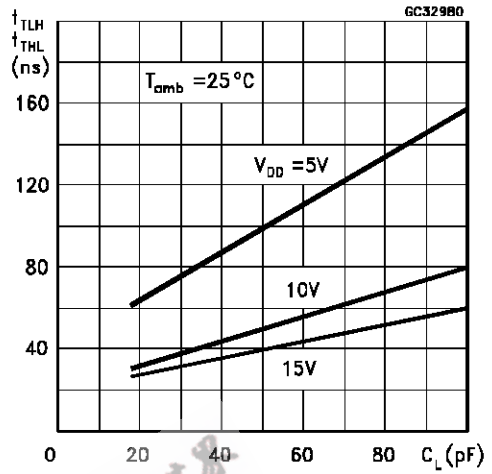

WAVEFORMS

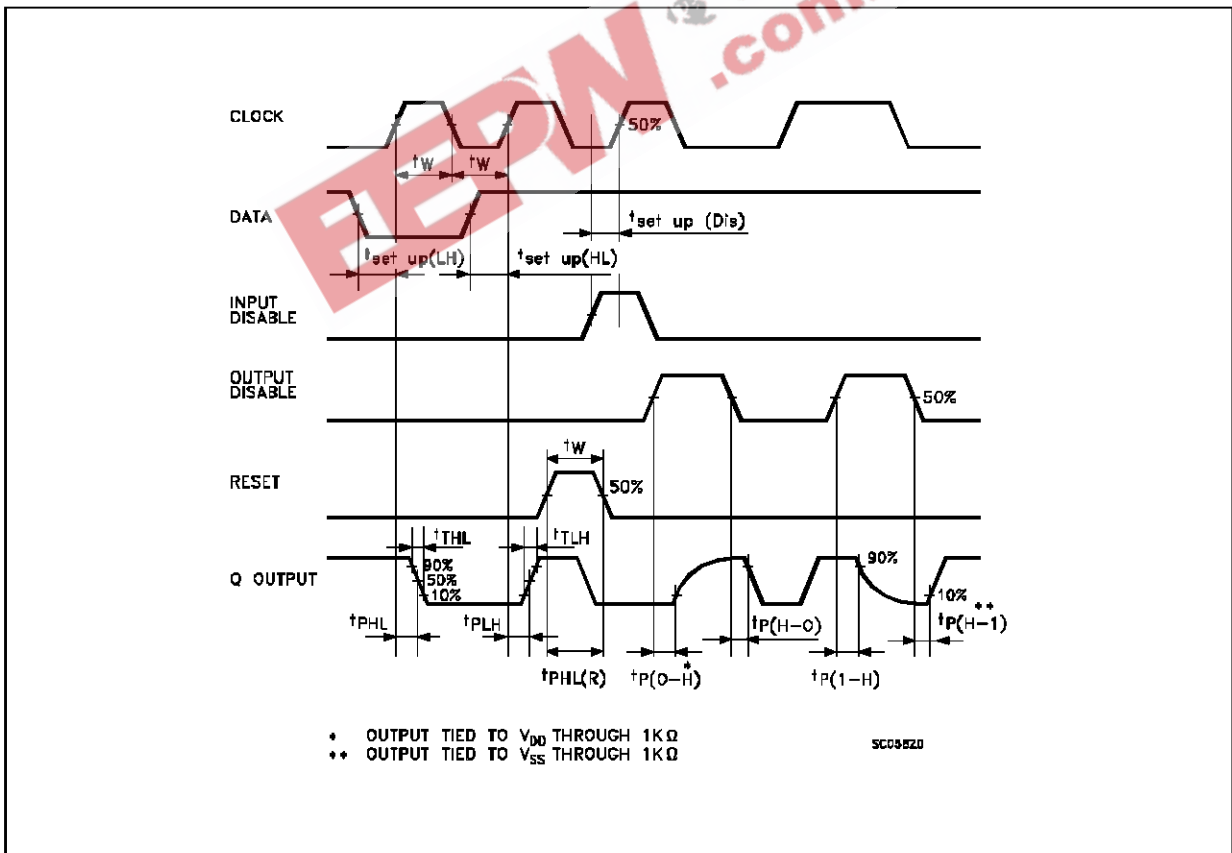

TEST CIRCUITS

Quiescent Device Current.

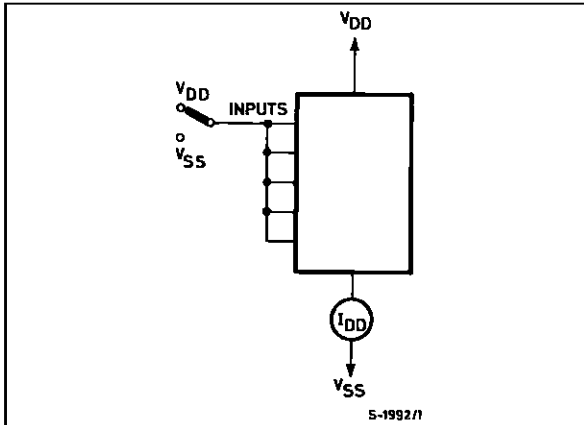

Noise Immunity.

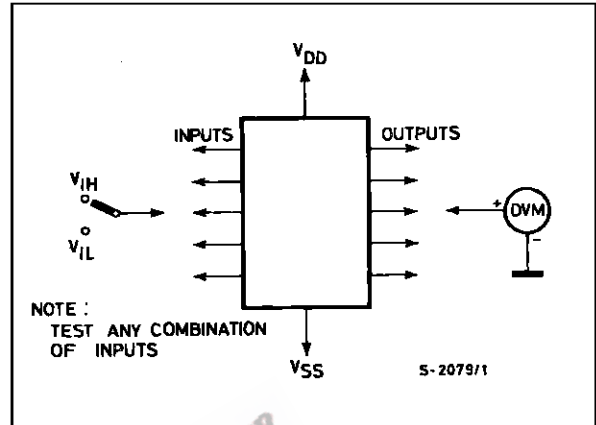

Input Leakage Current.

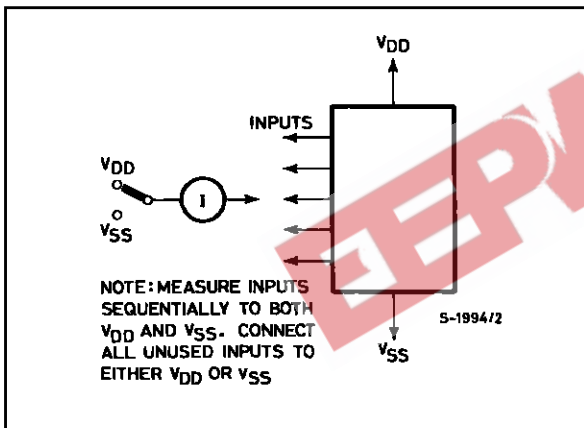

Plastic DIP16 (0.25) MECHANICAL DATA

DIM.	mm			inch		
	MIN.	TYP.	MAX.	MIN.	TYP.	MAX.
a1	0.51			0.020		
B	0.77		1.65	0.030		0.065
b		0.5			0.020	
b1		0.25			0.010	
D			20			0.787
E		8.5			0.335	
e		2.54			0.100	
e3		17.78			0.700	
F			7.1			0.280
I			5.1			0.201
L		3.3			0.130	
Z			1.27			0.050

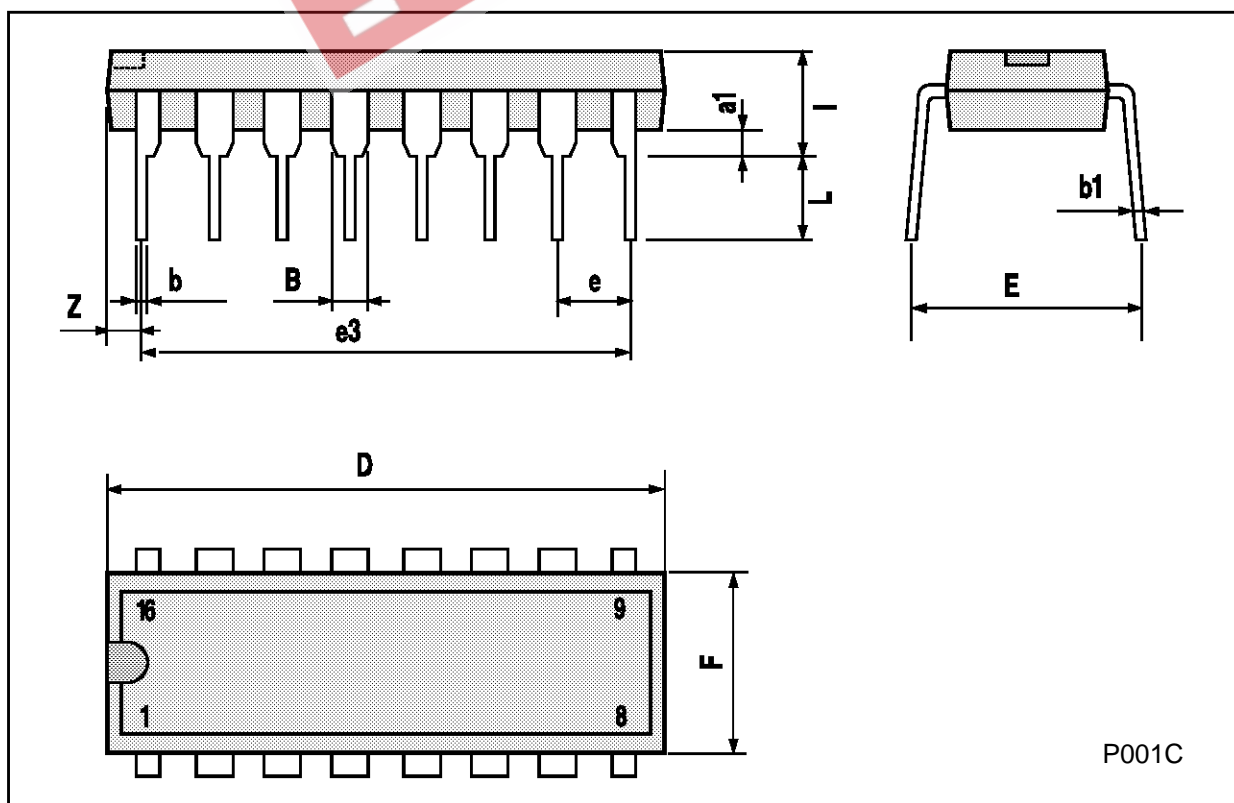

HCC/HCF4076B

Ceramic DIP16/1 MECHANICAL DATA

DIM.	mm			inch		
	MIN.	TYP.	MAX.	MIN.	TYP.	MAX.
A			20			0.787
B			7			0.276
D		3.3			0.130	
E	0.38			0.015		
e3		17.78			0.700	
F	2.29		2.79	0.090		0.110
G	0.4		0.55	0.016		0.022
H	1.17		1.52	0.046		0.060
L	0.22		0.31	0.009		0.012
M	0.51		1.27	0.020		0.050
N			10.3			0.406
P	7.8		8.05	0.307		0.317
Q			5.08			0.200

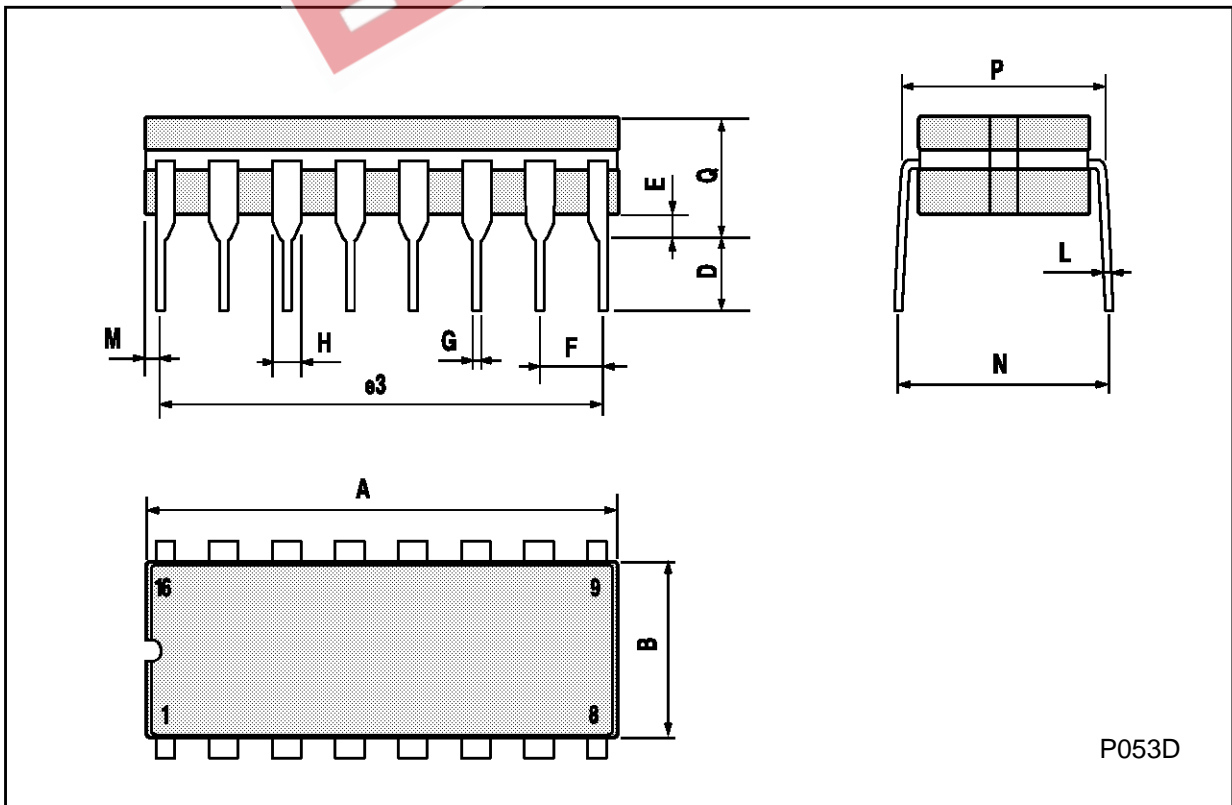

SO16 (Narrow) MECHANICAL DATA

DIM.	mm			inch		
	MIN.	TYP.	MAX.	MIN.	TYP.	MAX.
A			1.75			0.068
a1	0.1		0.2	0.004		0.007
a2			1.65			0.064
b	0.35		0.46	0.013		0.018
b1	0.19		0.25	0.007		0.010
C		0.5			0.019	
c1	45° (typ.)					
D	9.8		10	0.385		0.393
E	5.8		6.2	0.228		0.244
e		1.27			0.050	
e3		8.89			0.350	
F	3.8		4.0	0.149		0.157
G	4.6		5.3	0.181		0.208
L	0.5		1.27	0.019		0.050
M			0.62			0.024
S	8° (max.)					

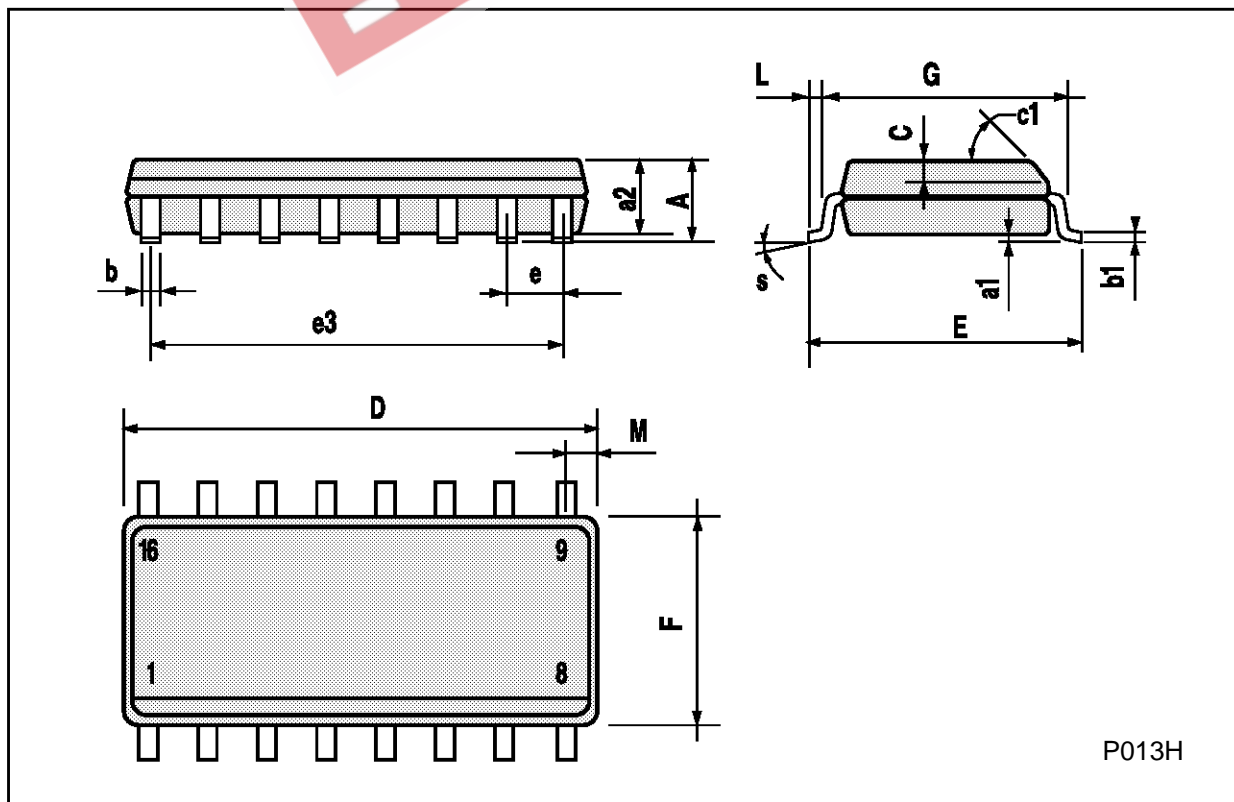

PLCC20 MECHANICAL DATA

DIM.	mm			inch		
	MIN.	TYP.	MAX.	MIN.	TYP.	MAX.
A	9.78		10.03	0.385		0.395
B	8.89		9.04	0.350		0.356
D	4.2		4.57	0.165		0.180
d1		2.54			0.100	
d2		0.56			0.022	
E	7.37		8.38	0.290		0.330
e		1.27			0.050	
e3		5.08			0.200	
F		0.38			0.015	
G			0.101			0.004
M		1.27			0.050	
M1		1.14			0.045	

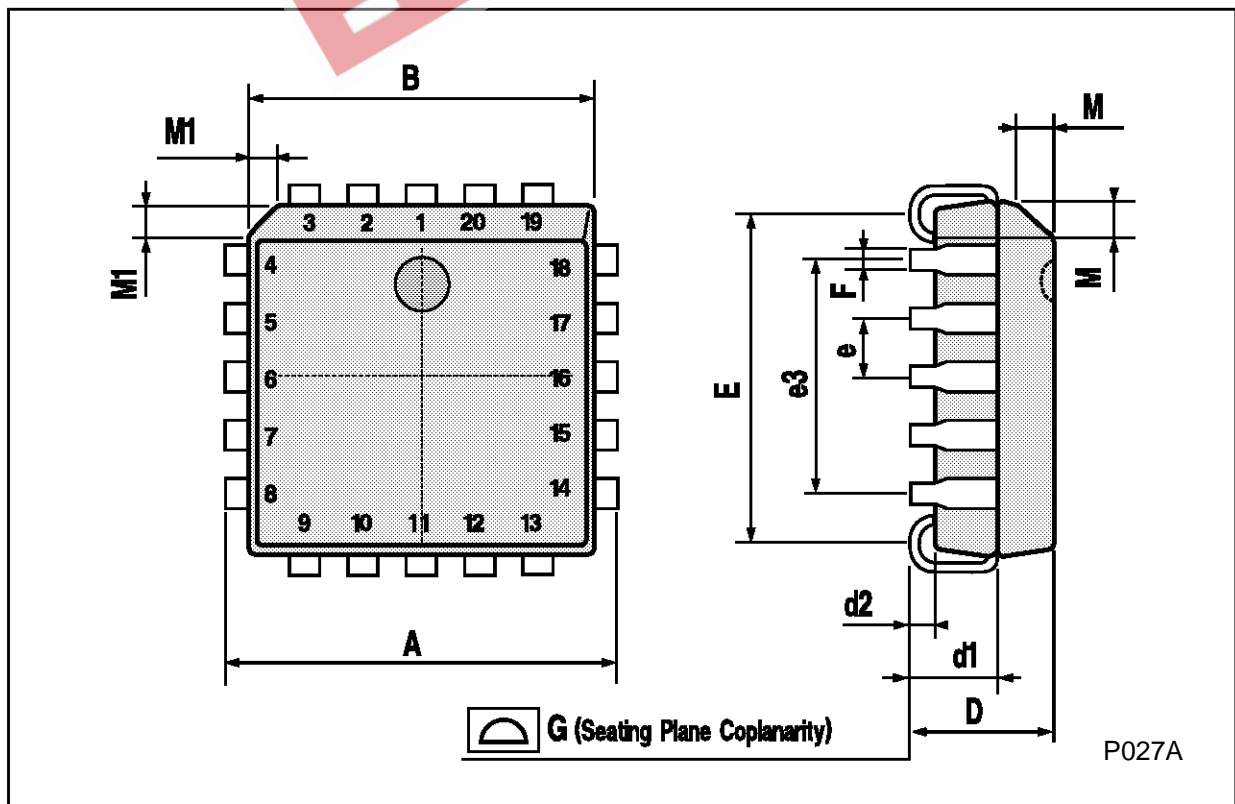

EEPW 电子產品世界
.com.cn

Information furnished is believed to be accurate and reliable. However, SGS-THOMSON Microelectronics assumes no responsibility for the consequences of use of such information nor for any infringement of patents or other rights of third parties which may result from its use. No license is granted by implication or otherwise under any patent or patent rights of SGS-THOMSON Microelectronics. Specifications mentioned in this publication are subject to change without notice. This publication supersedes and replaces all information previously supplied. SGS-THOMSON Microelectronics products are not authorized for use as critical components in life support devices or systems without express written approval of SGS-THOMSON Microelectronics.

© 1994 SGS-THOMSON Microelectronics - All Rights Reserved

SGS-THOMSON Microelectronics GROUP OF COMPANIES
Australia - Brazil - France - Germany - Hong Kong - Italy - Japan - Korea - Malaysia - Malta - Morocco - The Netherlands -
Singapore - Spain - Sweden - Switzerland - Taiwan - Thailand - United Kingdom - U.S.A