

DATA SHEET

EEPW 电子产品世界
.com.cn

74F3040

Dual 4-input NAND 30 Ω line driver

Product specification
IC15 Data Handbook

1990 Jan 29

Dual 4-input NAND 30Ω line driver

74F3040

FEATURES

- 30Ω line driver
- 160mA output drive capability in the Low state
- 67mA output drive capability in the High state
- High speed
- Facilitates incident wave switching
- 3nh lead inductance each on V_{CC} and GND when both side pins are used

DESCRIPTION

The 74F3040 is a high current Line Driver composed of two 4-input NAND gates. It has been designed to deal with the transmission line effects of PC boards which appear when fast edge rates are used.

The drive capability of the 74F3040 is 67mA source and 160mA sink with a V_{CC} as low as 4.5V. This guarantees incident wave switching with V_{OH} not less than 2.0V and V_{OL} not more than 0.8V while driving impedances as low as 30Ω. This is applicable with any combination of outputs using continuous duty.

The propagation delay of the part is minimally affected by reflections when terminated only by the TTL inputs of other devices. Performance may be improved by full or partial line termination.

PIN CONFIGURATION

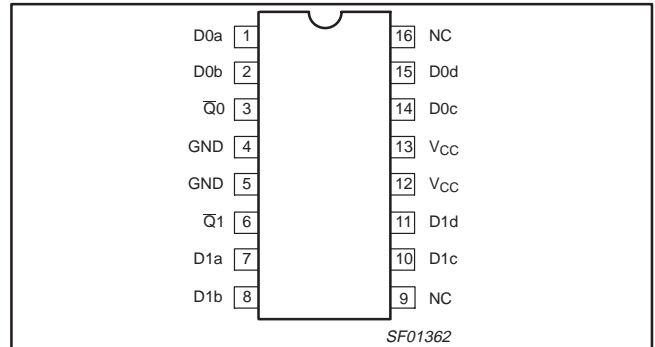

TYPE	TYPICAL PROPAGATION DELAY	TYPICAL SUPPLY CURRENT (TOTAL)
74F3040	2.0ns	10mA

ORDERING INFORMATION

DESCRIPTION	COMMERCIAL RANGE V _{CC} = 5V ±10%, T _{amb} = 0°C to +70°C	PACKAGE DRAWING NUMBER
16-pin Plastic DIP	N74F3040N	SOT38-4
16-pin Plastic SOL	N74F3040D	SOT162-1

INPUT AND OUTPUT LOADING AND FAN-OUT TABLE

PINS	DESCRIPTION	74F(U.L.) HIGH/LOW	LOAD VALUE HIGH/LOW
Dna, Dnb, Dnc, Dnd	Data inputs	1.0/1.0	20μA/0.6mA
Qn	Data outputs	3350/266	67mA/160mA

NOTE: One (1.0) FAST unit load is defined as: 20μA in the High state and 0.6mA in the Low state.

LOGIC SYMBOL

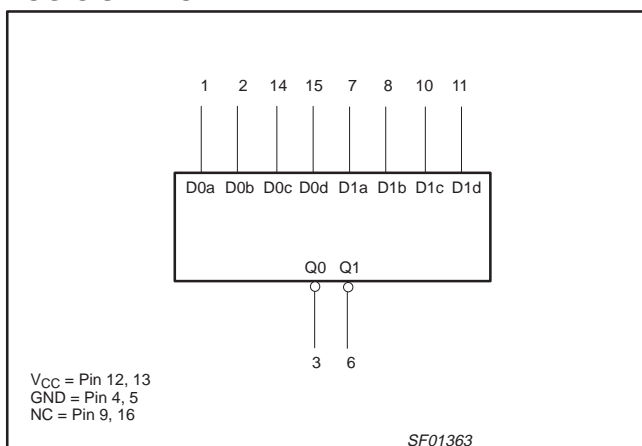

IEC/IEEE SYMBOL

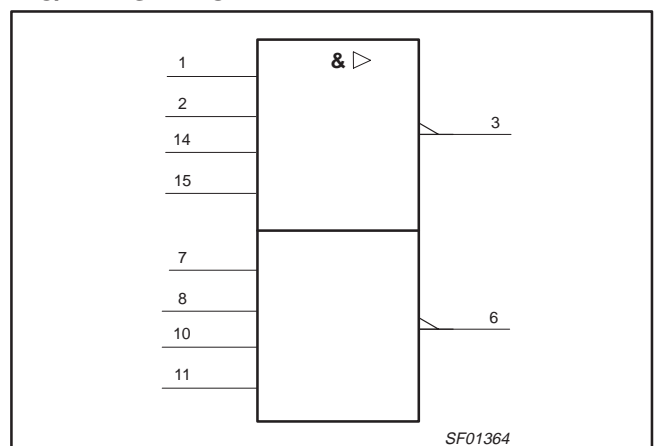

Dual 4-input NAND 30Ω line driver

74F3040

LOGIC DIAGRAM

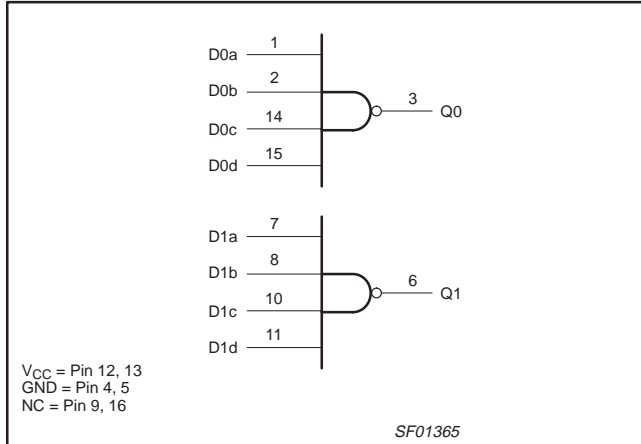

FUNCTION TABLE

INPUTS				OUTPUT
Dna	Dnb	Dnc	Dnd	\bar{Q}_n
L	X	X	X	H
X	L	X	X	H
X	X	L	X	H
X	X	X	L	H
H	H	H	H	L

H = High voltage level
 L = Low voltage level
 X = Don't care

ABSOLUTE MAXIMUM RATINGS

(Operation beyond the limits set forth in this table may impair the useful life of the device. Unless otherwise noted these limits are over the operating free-air temperature range.)

SYMBOL	PARAMETER	RATING	UNIT
V_{CC}	Supply voltage	-0.5 to +7.0	V
V_{IN}	Input voltage	-0.5 to +7.0	V
I_{IN}	Input current	-30 to +5	mA
V_{OUT}	Voltage applied to output in High output state	-0.5 to V_{CC}	V
I_{OUT}	Current applied to output in Low output state	320	mA
T_{amb}	Operating free-air temperature range	0 to +70	°C
T_{stg}	Storage temperature range	-65 to +150	°C

RECOMMENDED OPERATING CONDITIONS

SYMBOL	PARAMETER	LIMITS			UNIT
		MIN	NOM	MAX	
V_{CC}	Supply voltage	4.5	5.0	5.5	V
V_{IH}	High-level input voltage	2.0			V
V_{IL}	Low-level input voltage			0.8	V
I_{IK}	Input clamp current			-18	mA
I_{OH}	High-level output current			-67	mA
I_{OL}	Low-level output current			160	mA
T_{amb}	Operating free-air temperature range	0		+70	°C

Dual 4-input NAND 30Ω line driver

74F3040

DC ELECTRICAL CHARACTERISTICS

(Over recommended operating free-air temperature range unless otherwise noted.)

SYMBOL	PARAMETER	TEST CONDITIONS ¹			LIMITS			UNIT
					MIN	TYP ²	MAX	
V _{OH}	High-level output current	V _{CC} = MIN V _{IL} = MAX V _{IH} = MIN	I _{OH} = -45mA	±10% V _{CC}	2.5			V
				±5% V _{CC}	2.7	3.4		V
			I _{OH1} = -67mA ³	±10% V _{CC}	2.0			V
V _{OL}	Low-level output current	V _{CC} = MIN V _{IL} = MAX V _{IH} = MIN	I _{OL} = 100mA	±10% V _{CC}		0.30	0.50	V
			I _{OL1} = 160mA ⁴	±5% V _{CC}		0.30	0.50	V
V _{IK}	Input clamp voltage	V _{CC} = MIN, I _I = I _{IK}				-0.73	-1.2	V
I _I	Input current at maximum input voltage	V _{CC} = MAX, V _I = 7.0V					100	μA
I _{IH}	High-level input current	V _{CC} = MAX, V _I = 2.7V					20	μA
I _{IL}	Low-level input current	V _{CC} = MAX, V _I = 0.5V					-0.6	mA
I _O	Output current ⁵	V _{CC} = MAX, V _O = 2.25V			-100		-200	mA
I _{CC}	Supply current (total)	I _{CCH}	V _{CC} = MAX			3.0	5.0	mA
		I _{CCL}				16	22	mA

NOTES:

- For conditions shown as MIN or MAX, use the appropriate value specified under recommended operating conditions for the applicable type.
- All typical values are at V_{CC} = 5V, T_{amb} = 25°C.
- I_{OH1} is the current necessary to guarantee the Low-to-High transition in a 30Ω transmission line on the incident wave.
- I_{OL1} is the current necessary to guarantee the High-to-Low transition in a 30Ω transmission line on the incident wave.
- I_O is tested under conditions that produce current approximately one half of the true short-circuit output current (I_{OS}).

AC ELECTRICAL CHARACTERISTICS

SYMBOL	PARAMETER	TEST CONDITION	LIMITS					UNIT
			T _{amb} = +25°C V _{CC} = +5.0V C _L = 50pF, R _L = 500Ω			T _{amb} = 0°C to +70°C V _{CC} = +5.0V ± 10% C _L = 50pF, R _L = 500Ω		
			MIN	TYP	MAX	MIN	MAX	
t _{PLH} t _{PHL}	Propagation delay D _{na} , D _{nb} , D _{nc} , D _{nd} to Q _n	Waveform 1	1.0 1.0	2.0 2.0	5.0 4.5	1.0 1.0	5.5 5.0	ns

AC WAVEFORMS

For all waveforms, V_M = 1.5V.

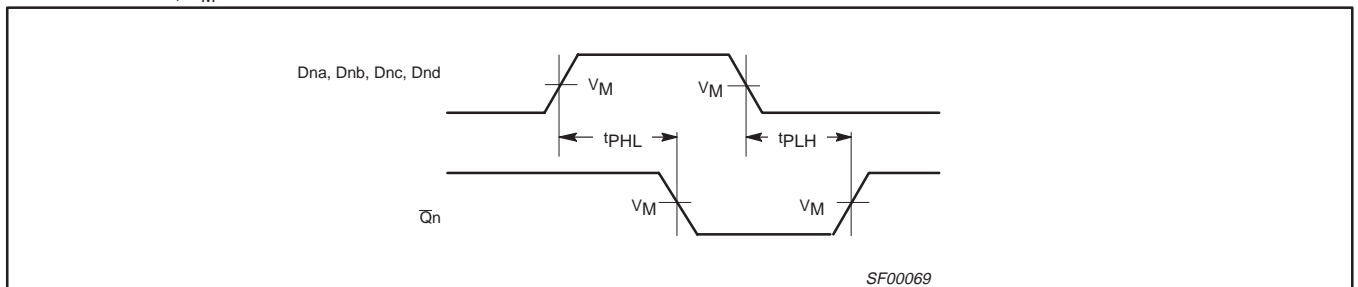

Waveform 1. Propagation Delay for Inputs to Output

Dual 4-input NAND 30Ω line driver

74F3040

TEST CIRCUIT AND WAVEFORMS

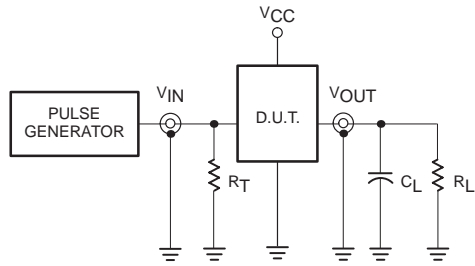

Test Circuit for Totem-Pole Outputs

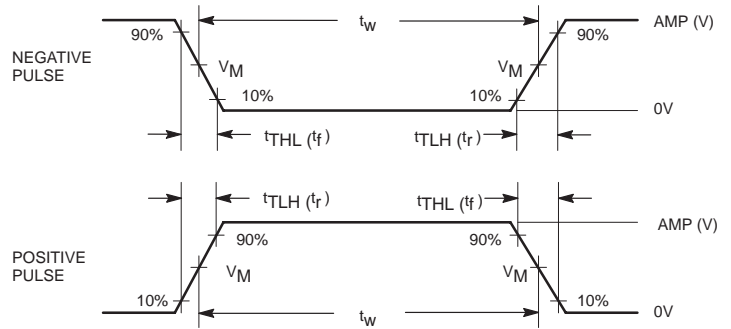

Input Pulse Definition

DEFINITIONS:

- R_L = Load resistor; see AC ELECTRICAL CHARACTERISTICS for value.
- C_L = Load capacitance includes jig and probe capacitance; see AC ELECTRICAL CHARACTERISTICS for value.
- R_T = Termination resistance should be equal to Z_{OUT} of pulse generators.

family	INPUT PULSE REQUIREMENTS					
	amplitude	V _M	rep. rate	t _w	t _{TLH}	t _{THL}
74F	3.0V	1.5V	1MHz	500ns	2.5ns	2.5ns

SF00006

Dual 4-input NAND 30 Ω line driver

74F3040

DIP20: plastic dual in-line package; 20 leads (300 mil)

SOT146-1

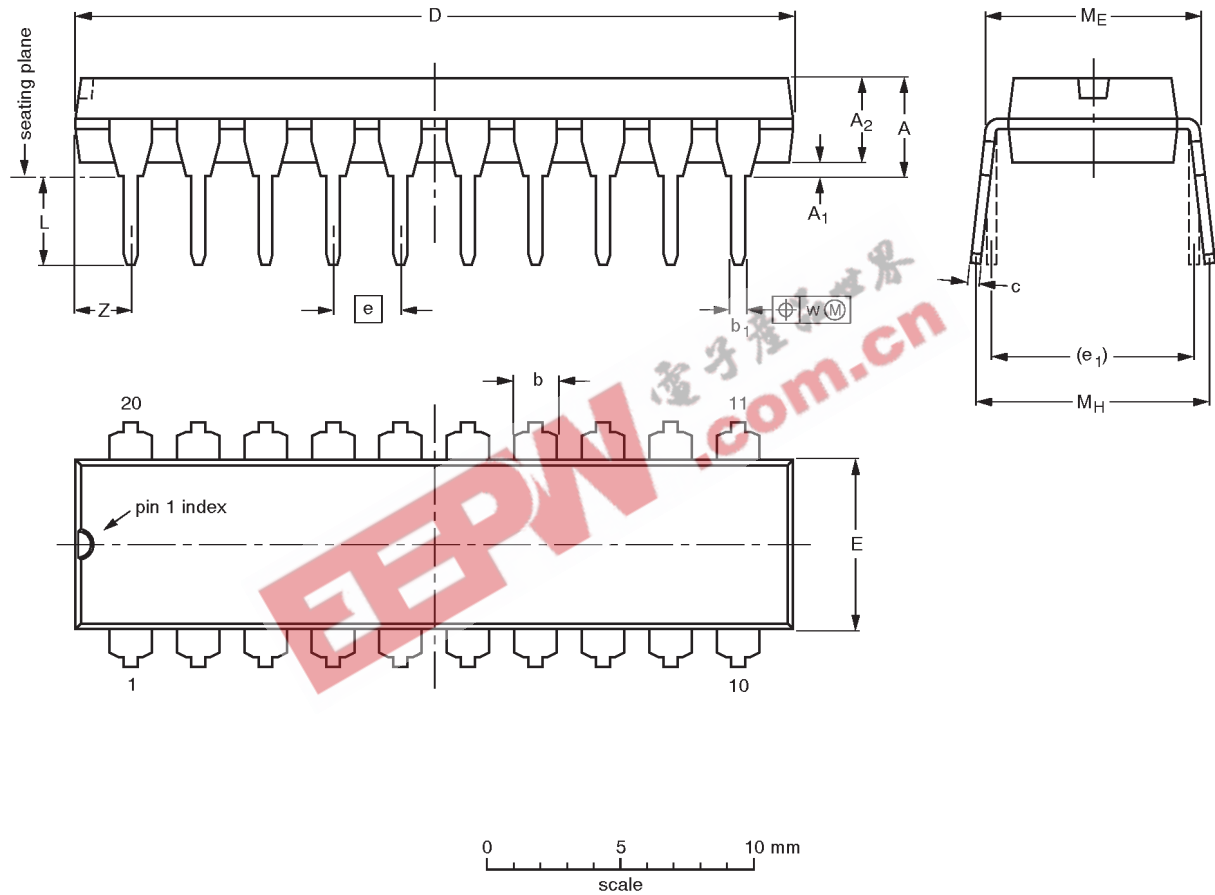

DIMENSIONS (inch dimensions are derived from the original mm dimensions)

UNIT	A max.	A ₁ min.	A ₂ max.	b	b ₁	c	D ⁽¹⁾	E ⁽¹⁾	e	e ₁	L	M _E	M _H	w	Z ⁽¹⁾ max.
mm	4.2	0.51	3.2	1.73 1.30	0.53 0.38	0.36 0.23	26.92 26.54	6.40 6.22	2.54	7.62	3.60 3.05	8.25 7.80	10.0 8.3	0.254	2.0
inches	0.17	0.020	0.13	0.068 0.051	0.021 0.015	0.014 0.009	1.060 1.045	0.25 0.24	0.10	0.30	0.14 0.12	0.32 0.31	0.39 0.33	0.01	0.078

Note

1. Plastic or metal protrusions of 0.25 mm maximum per side are not included.

OUTLINE VERSION	REFERENCES				EUROPEAN PROJECTION	ISSUE DATE
	IEC	JEDEC	EIAJ			
SOT146-1			SC603			92-11-17 95-05-24

Dual 4-input NAND 30 Ω line driver

74F3040

SO20: plastic small outline package; 20 leads; body width 7.5 mm

SOT163-1

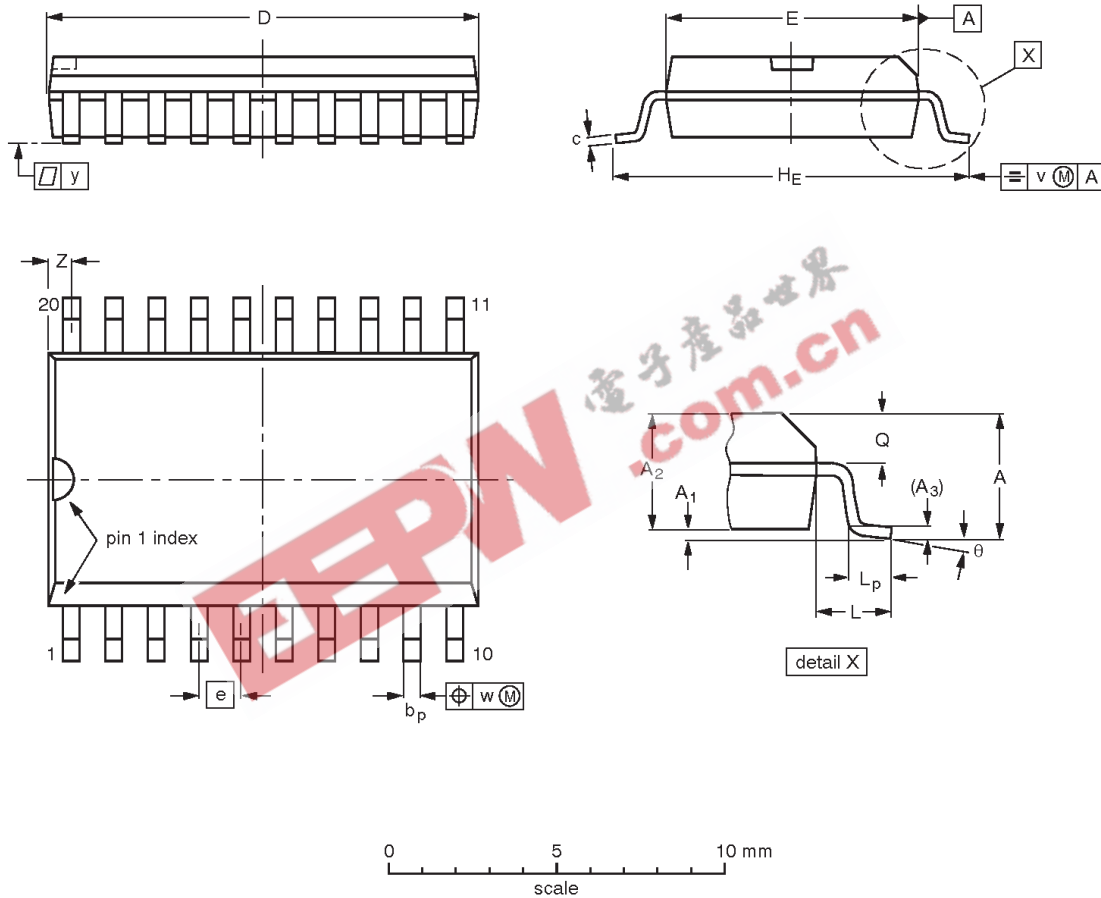

DIMENSIONS (inch dimensions are derived from the original mm dimensions)

UNIT	A max.	A ₁	A ₂	A ₃	b _p	c	D ⁽¹⁾	E ⁽¹⁾	e	H _E	L	L _p	Q	v	w	y	z ⁽¹⁾	θ
mm	2.65	0.30 0.10	2.45 2.25	0.25	0.49 0.36	0.32 0.23	13.0 12.6	7.6 7.4	1.27	10.65 10.00	1.4	1.1 0.4	1.1 1.0	0.25	0.25	0.1	0.9 0.4	8° 0°
inches	0.10	0.012 0.004	0.096 0.089	0.01	0.019 0.014	0.013 0.009	0.51 0.49	0.30 0.29	0.050	0.42 0.39	0.055	0.043 0.016	0.043 0.039	0.01	0.01	0.004	0.035 0.016	

Note

1. Plastic or metal protrusions of 0.15 mm maximum per side are not included.

OUTLINE VERSION	REFERENCES				EUROPEAN PROJECTION	ISSUE DATE
	IEC	JEDEC	EIAJ			
SOT163-1	075E04	MS-013AC				92-11-17 95-01-24

Dual 4-input NAND 30 Ω line driver

74F3040

Data sheet status

Data sheet status	Product status	Definition [1]
Objective specification	Development	This data sheet contains the design target or goal specifications for product development. Specification may change in any manner without notice.
Preliminary specification	Qualification	This data sheet contains preliminary data, and supplementary data will be published at a later date. Philips Semiconductors reserves the right to make changes at any time without notice in order to improve design and supply the best possible product.
Product specification	Production	This data sheet contains final specifications. Philips Semiconductors reserves the right to make changes at any time without notice in order to improve design and supply the best possible product.

[1] Please consult the most recently issued datasheet before initiating or completing a design.

Definitions

Short-form specification — The data in a short-form specification is extracted from a full data sheet with the same type number and title. For detailed information see the relevant data sheet or data handbook.

Limiting values definition — Limiting values given are in accordance with the Absolute Maximum Rating System (IEC 134). Stress above one or more of the limiting values may cause permanent damage to the device. These are stress ratings only and operation of the device at these or at any other conditions above those given in the Characteristics sections of the specification is not implied. Exposure to limiting values for extended periods may affect device reliability.

Application information — Applications that are described herein for any of these products are for illustrative purposes only. Philips Semiconductors make no representation or warranty that such applications will be suitable for the specified use without further testing or modification.

Disclaimers

Life support — These products are not designed for use in life support appliances, devices or systems where malfunction of these products can reasonably be expected to result in personal injury. Philips Semiconductors customers using or selling these products for use in such applications do so at their own risk and agree to fully indemnify Philips Semiconductors for any damages resulting from such application.

Right to make changes — Philips Semiconductors reserves the right to make changes, without notice, in the products, including circuits, standard cells, and/or software, described or contained herein in order to improve design and/or performance. Philips Semiconductors assumes no responsibility or liability for the use of any of these products, conveys no license or title under any patent, copyright, or mask work right to these products, and makes no representations or warranties that these products are free from patent, copyright, or mask work right infringement, unless otherwise specified.

Philips Semiconductors
811 East Arques Avenue
P.O. Box 3409
Sunnyvale, California 94088-3409
Telephone 800-234-7381

© Copyright Philips Electronics North America Corporation 1998
All rights reserved. Printed in U.S.A.

print code

Date of release: 05-96

Document order number:

9397-750-05205

Let's make things better.