

P4C168, P4C169, P4C170 ULTRA HIGH SPEED 4K x 4 STATIC CMOS RAMS



FEATURES

- Full CMOS, 6T Cell
- High Speed (Equal Access and Cycle Times)
 - 12/15/20/25ns (Commercial)
 - 20/25/35ns (P4C168 Military)
- Low Power Operation (Commercial)
 - 715 mW Active
 - 193 mW Standby (TTL Input) P4C168
 - 83 mW Standby (CMOS Input) P4C168
- Single 5V±10% Power Supply
- Fully TTL Compatible, Common I/O Ports
- Three Options
 - P4C168 Low Power Standby Mode
 - P4C169 Fast Chip Select Control
 - P4C170 Fast Chip Select, Output Enable Controls
- Standard Pinout (JEDEC Approved)
 - P4C168: 20-pin DIP, SOJ and SOIC
 - P4C169: 20-pin DIP and SOIC
 - P4C170: 22-pin DIP



DESCRIPTION

The P4C168, P4C169 and P4C170 are a family of 16,384-bit ultra high-speed static RAMs organized as 4K x 4. All three devices have common input/output ports. The P4C168 enters the standby mode when the chip enable (\overline{CE}) control goes high; with CMOS input levels, power consumption is only 83mW in this mode. Both the P4C169 and the P4C170 offer a fast chip select access time that is only 67% of the address access time. In addition, the P4C170 includes an output enable (\overline{OE}) control to eliminate data bus contention. The RAMs operate from a single 5V ± 10% tolerance power supply.

Access times as fast as 12 nanoseconds are available, permitting greatly enhanced system operating speeds. CMOS is used to reduce power consumption to a low 715 mW active, 193 mW standby.

The P4C168 and P4C169 are available in 20-pin (P4C170 in 22-pin) 300 mil DIP packages providing excellent board level densities. The P4C168 is also available in 20-pin 300 mil SOIC and SOJ packages.

The P4C169 is also available in a 20-pin 300 mil SOIC package. The P4C170 is also available in a 22-pin 300 mil SOJ package.



FUNCTIONAL BLOCK DIAGRAM

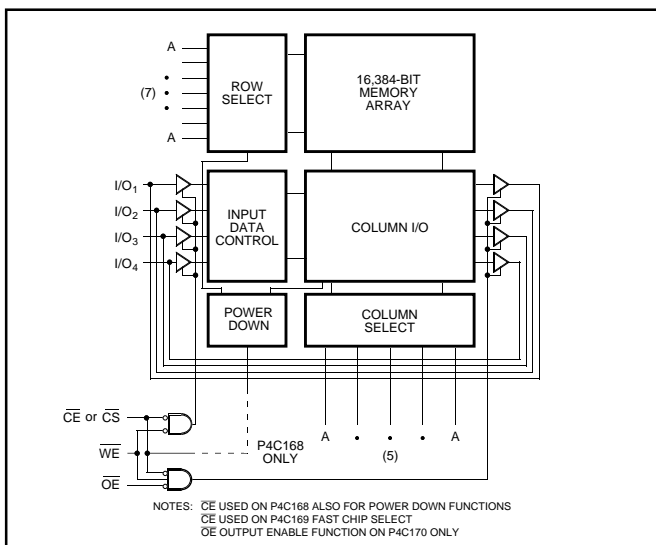

PIN CONFIGURATIONS

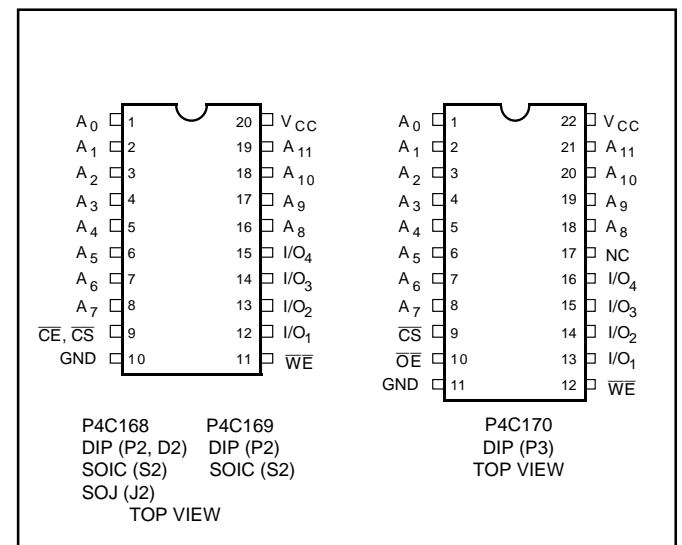

MAXIMUM RATINGS⁽¹⁾

Symbol	Parameter	Value	Unit
V_{CC}	Power Supply Pin with Respect to GND	-0.5 to +7	V
V_{TERM}	Terminal Voltage with Respect to GND (up to 7.0V)	-0.5 to $V_{CC} + 0.5$	V
T_A	Operating Temperature	-55 to +125	°C

Symbol	Parameter	Value	Unit
T_{BIAS}	Temperature Under Bias	-55 to +125	°C
T_{STG}	Storage Temperature	-65 to +150	°C
P_T	Power Dissipation	1.0	W
I_{OUT}	DC Output Current	50	mA

RECOMMENDED OPERATING CONDITIONS

Grade ⁽²⁾	Ambient Temp	Gnd	V_{CC}
Commercial	0°C to 70°C	0V	5.0V ± 10%
Military	-55°C to +125°C	0V	5.0V ± 10%

CAPACITANCES⁽⁴⁾

($V_{CC} = 5.0V$, $T_A = 25°C$, $f = 1.0MHz$)

Symbol	Parameter	Conditions	Typ.	Unit
C_{IN}	Input Capacitance	$V_{IN} = 0V$	5	pF
C_{OUT}	Output Capacitance	$V_{OUT} = 0V$	7	pF

DC ELECTRICAL CHARACTERISTICS

Symbol	Parameter	Test Conditions	P4C168/169/170		Unit
			Min	Max	
V_{IH}	Input High Voltage		2.2	$V_{CC} + 0.5$	V
V_{IL}	Input Low Voltage		-0.5(3)	0.8	V
V_{HC}	CMOS Input High Voltage		$V_{CC} - 0.2$	$V_{CC} + 0.5$	V
V_{LC}	CMOS Input Low Voltage		-0.5(3)	0.2	V
V_{CD}	Input Clamp Diode Voltage	$V_{CC} = \text{Min.}, I_{IN} = -18 \text{ mA}$		-1.2	V
V_{OL}	Output Low Voltage (TTL Load)	$I_{OL} = +8 \text{ mA}, V_{CC} = \text{Min.}$		0.4	V
V_{OLC}	Output Low Voltage (CMOS Load)	$I_{OLC} = +100 \mu\text{A}, V_{CC} = \text{Min.}$		0.2	V
V_{OH}	Output High Voltage (TTL Load)	$I_{OH} = -4 \text{ mA}, V_{CC} = \text{Min.}$	2.4		V
V_{OHC}	Output High Voltage (CMOS Load)	$I_{OHC} = -100 \mu\text{A}, V_{CC} = \text{Min.}$	$V_{CC} - 0.2$		V
I_{LI}	Input Leakage Current	$V_{CC} = \text{Max.}, V_{IN} = \text{GND to } V_{CC}$	Mil. Comm'l -10 -5	+10 +5	μA
I_{LO}	Output Leakage Current	$V_{CC} = \text{Max.}, \overline{CS} = V_{IH}, V_{OUT} = \text{GND to } V_{CC}$	Mil. Comm'l -10 -5	+10 +5	μA
I_{CC}	Dynamic Operating Current	$V_{CC} = \text{Max.}, f = \text{Max.}, \text{Outputs Open}$	—	130	mA
I_{SB}	Standby Power Supply Current (TTL Input Levels) P4C168 only	$\overline{CE} \geq V_{IH}, V_{CC} = \text{Max.}, f = \text{Max.}, \text{Outputs Open}$	—	35	mA
I_{SB1}	Standby Power Supply Current (CMOS Input Levels) P4C168 only	$\overline{CE} \geq V_{HC}, V_{CC} = \text{Max.}, f = 0, V_{IN} \leq V_{LC} \text{ or } V_{IN} \geq V_{HC}$	—	15	mA

AC CHARACTERISTICS—READ CYCLE $(V_{CC} = 5V \pm 10\%$, All Temperature Ranges)⁽²⁾

Sym.	Parameter	-12		-15		-20		-25		-35		Unit
		Min	Max	Min	Max	Min	Max	Min	Max	Min	Max	
t_{RC}	Read Cycle Time	12		15		20		25		35		ns
t_{AA}	Address Access Time		12		15		20		25		35	ns
t_{AC}^{\S}	Chip Enable Access Time		12		15		20		25		35	ns
t_{AC}^{\ddagger}	Chip Select Access Time		8		9		12		15		20	ns
t_{OH}	Output Hold from Address Change	2		2		2		2		2		ns
t_{LZ}^{\ddagger}	Chip Enable to Output in Low Z	2		2		2		2		2		ns
t_{HZ}^{\ddagger}	Chip Disable to Output in High Z		6		7		9		10		15	ns
t_{OE}^{\ddagger}	Output Enable to Data Valid		8		10		12		15		15	ns
t_{OLZ}^{\ddagger}	Output Enable to Output in Low Z	0		0		0		0		0		ns
t_{OHZ}^{\ddagger}	Output Disable to Output in High Z		6		7		9		11		15	ns
t_{RCS}	Read Command Setup Time	0		0		0		0		0		ns
t_{RCH}	Read Command Hold Time	0		0		0		0		0		ns
t_{PU}^{\S}	Chip Enable to Power Up Time	0		0		0		0		0		ns
t_{PD}^{\S}	Chip Disable to Power Down Time		12		15		20		25		35	ns

§ P4C168 only

† P4C170 only

‡ Chip Select/Deselect for P4C169 and P4C170

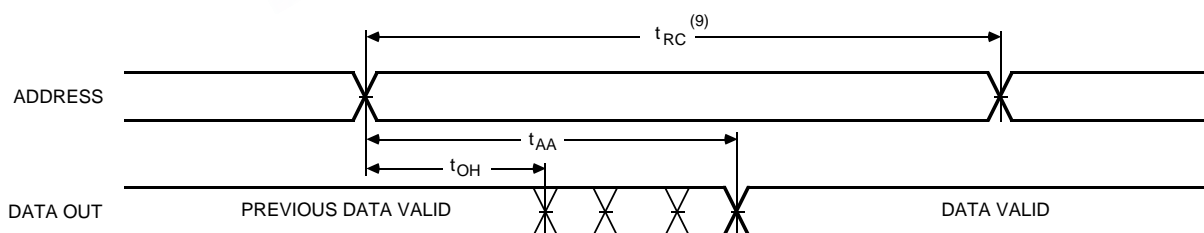
TIMING WAVEFORM OF READ CYCLE NO. 1 (ADDRESS CONTROLLED)^(5,6)**Notes:**5. \overline{WE} is HIGH for READ cycle.6. \overline{CE}/CS and \overline{OE} are LOW for READ cycle.

TIMING WAVEFORM OF READ CYCLE NO. 2 ($\overline{CE}/\overline{CS}$ CONTROLLED)^(5,7)

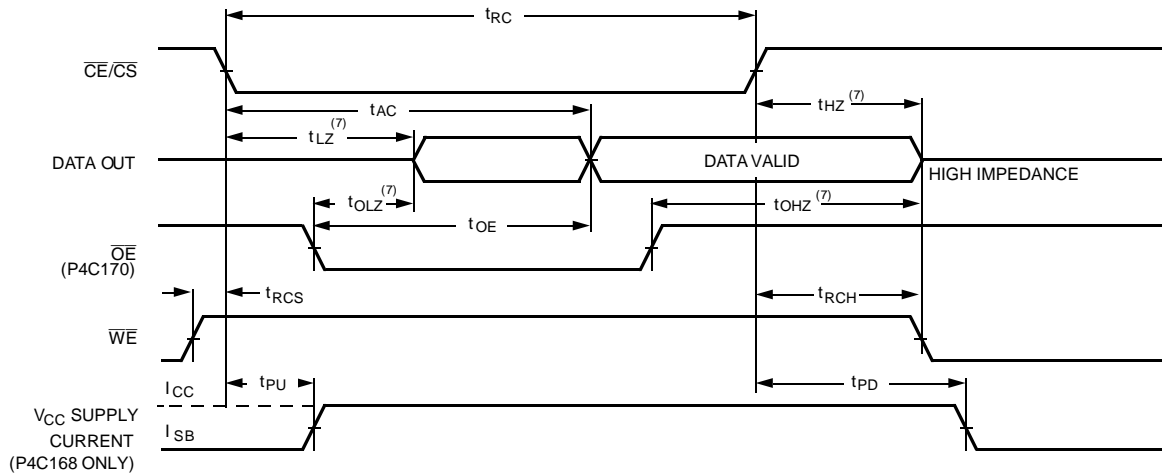

TIMING WAVEFORM OF READ CYCLE NO. 3—P4C170 ONLY (\overline{OE} CONTROLLED)⁽⁵⁾

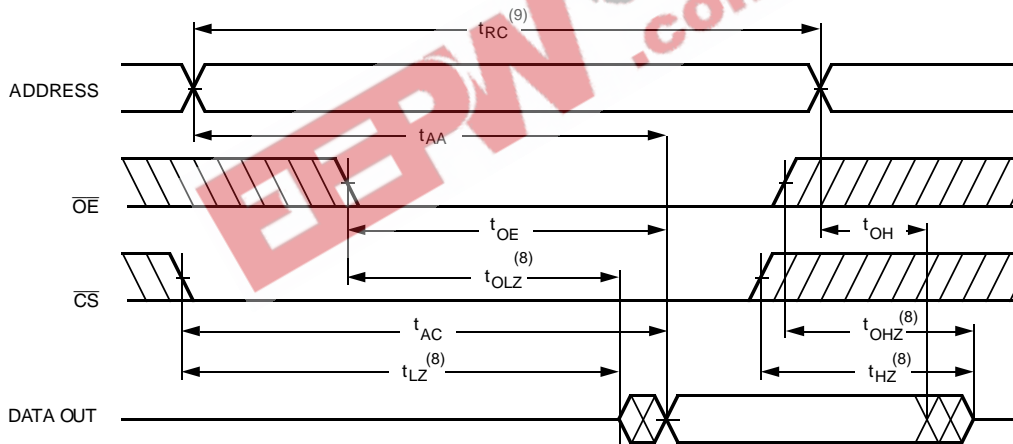

Notes:

- 7. ADDRESS must be valid prior to, or coincident with $\overline{CE}/\overline{CS}$ transition low. For Fast CS, t_{AA} must still be met.
- 8. Transition is measured $\pm 200\text{mV}$ from steady state voltage prior to change, with loading as specified in Figure 1.

- 9. Read Cycle Time is measured from t_{H52105} valid address to the first transitioning address.

AC ELECTRICAL CHARACTERISTICS - WRITE CYCLE

($V_{CC} = 5V \pm 10\%$, All Temperature Ranges)⁽²⁾

Sym.	Parameter	-12		-15		-20		-25		-35		Unit
		Min	Max	Min	Max	Min	Max	Min	Max	Min	Max	
t_{WC}	Write Cycle Time	12		15		18		20		35		ns
t_{CW}	Chip Enable Time to End of Write	12		15		18		20		30		ns
t_{AW}	Address Valid to End of Write	12		15		18		20		30		ns
t_{AS}	Address Set-up Time	0		0		0		0		0		ns
t_{WP}	Write Pulse Width	12		15		18		20		30		ns
t_{AH}	Address Hold Time	0		0		0		0		0		ns
t_{DW}	Data Valid to End of Write	7		8		10		10		15		ns
t_{DH}	Data Hold Time	0		0		0		0		0		ns
t_{WZ}	Write Enable to Output in High Z		4		5		7		7		13	ns
t_{OW}	Output Active from End of Write	0		0		0		0		0		ns

TIMING WAVEFORM OF WRITE CYCLE NO. 1 (\overline{WE} CONTROLLED)⁽¹⁰⁾

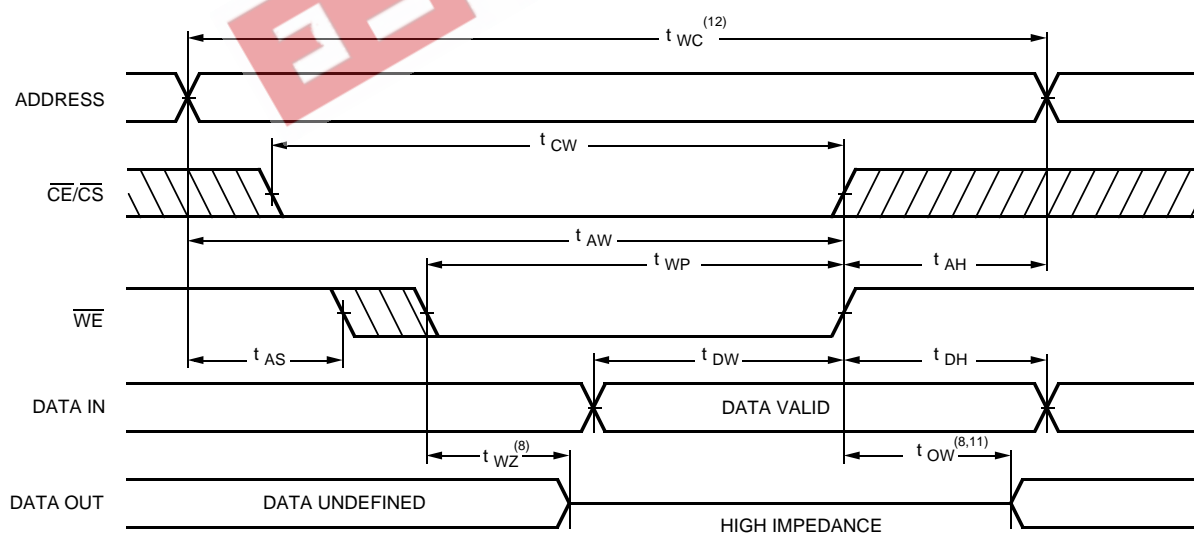

Notes:

10. $\overline{CE}/\overline{CS}$ and \overline{WE} must be LOW for WRITE cycle.
 11. If $\overline{CE}/\overline{CS}$ goes HIGH simultaneously with \overline{WE} HIGH, the output remains in a high impedance state.

12. Write Cycle Time is measured from the last valid address to the first transitioning address.

TIMING WAVEFORM OF WRITE CYCLE NO. 2 ($\overline{CE}/\overline{CS}$ CONTROLLED)⁽¹⁰⁾

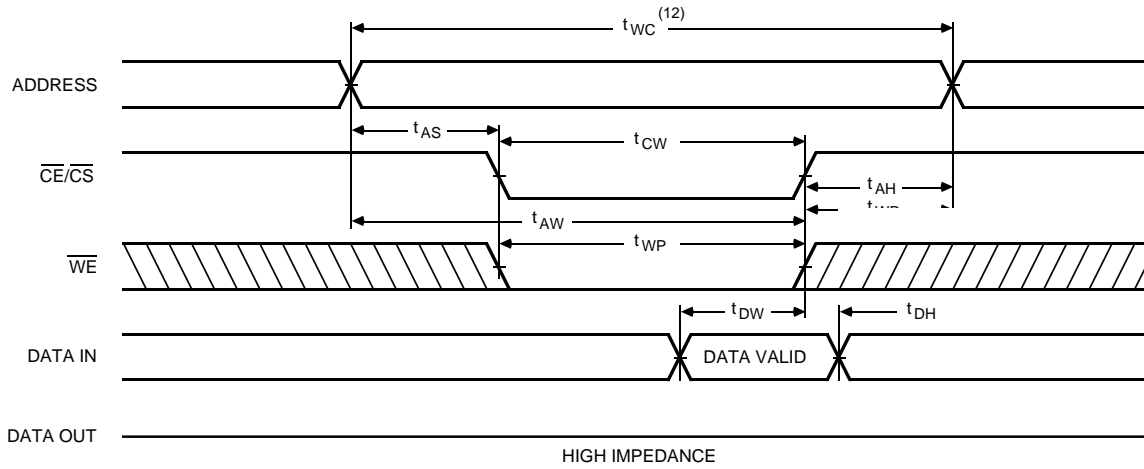

TRUTH TABLES

P4C168 (P4C169)

Mode	\overline{CE} (\overline{CS})	\overline{WE}	Output
Standby (Deselect)	H	X	High Z
Read	L	H	D _{OUT}
Write	L	L	High Z

P4C170

Mode	\overline{CE}	\overline{WE}	\overline{OE}	Output
Deselect	H	X	X	High Z
Read	L	H	L	D _{OUT}
Output Inhibit	L	H	H	High Z
Write	L	L	X	High Z

AC TEST CONDITIONS

Input Pulse Levels	GND to 3.0V
Input Rise and Fall Times	3ns
Input Timing Reference Level	1.5V
Output Timing Reference Level	1.5V
Output Load	See Figures 1 and 2

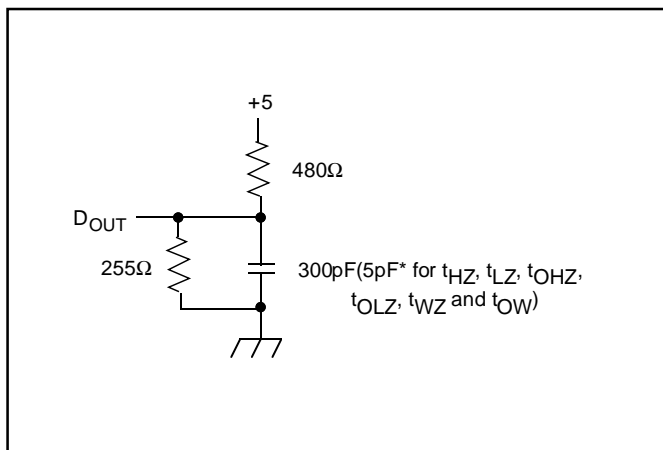

Figure 1. Output Load

* including scope and test fixture.

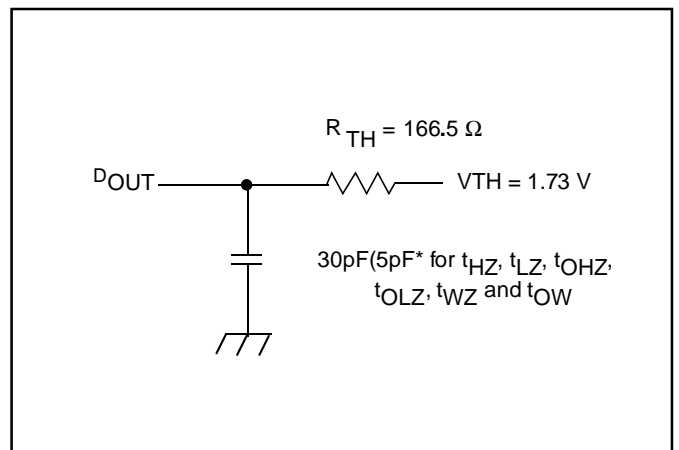

Figure 2. Thevenin Equivalent

Note:

Because of the ultra-high speed of the P4C168, P4C169 AND P4C170 care must be taken when testing these devices; an inadequate setup can cause a normal functioning part to be rejected as faulty. Long high-inductance leads that cause supply bounce must be avoided by bringing the V_{CC} and ground planes directly up to the contactor fingers. A 0.01 μF

high frequency capacitor is also required between V_{CC} and ground. To avoid signal reflections, proper termination must be used; for example, a 50Ω test environment should be terminated into a 50Ω load with 1.73V (Thevenin Voltage) at the comparator input, and a 116Ω resistor must be used in series with D_{OUT} to match 166Ω (Thevenin Resistance).

PACKAGE SUFFIX

Package Suffix	Description
P	Plastic DIP, 300 mil wide standard
S	Plastic SOIC, 300 mil wide standard
J	Plastic SOJ, 300 mil wide standard
D	CERDIP, 300 mil wide standard

TEMPERATURE RANGE SUFFIX

Temperature Range Suffix	Description
C	Commercial Temperature Range, 0°C – +70°C.
M	Military Temperature Range, –55°C – +125°C.
MB	Mil. Temp. with MIL-STD-883D Class B compliance

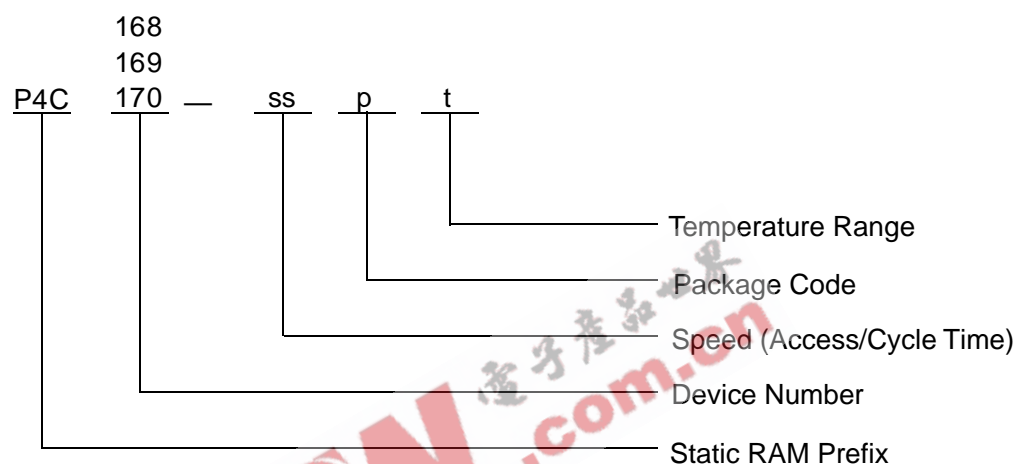
ORDERING INFORMATION

ss = Speed (access/cycle time in ns), e.g., 15, 20

p = Package code, i.e., P, S, D, J.

t = Temperature range, i.e., C, M, MB.

The P4C168 is also available per SMD #5962-86705

SELECTION GUIDE

The P4C168, P4C169 and P4C170 are available in the following temperature, speed and package options.

Temperature Range	Package	Speed (ns)				
		12	15	20	25	35
Commercial	Plastic DIP	-12PC	-15PC	-20PC	-25PC	N/A
	Plastic SOIC†	-12SC	-15SC	-20SC	-25SC	N/A
	Plastic SOJ††	-12JC	-15JC	-20JC	-25JC	N/A
Military Temp. (P4C168 only)	CERDIP	N/A	N/A	-20DM	-25DM	-35DM
Military Processed* (P4C168 only)	CERDIP	N/A	N/A	-20DMB	-25DMB	-35DMB

† P4C168 and P4C169 only.

†† P4C168

* Military temperature range with MIL-STD-883, Class B processing.

N/A = Not available

EEPW 电子产品世界
.com.cn