

SYNCHRONOUS PRESETTABLE 4-BIT COUNTER

- HIGH SPEED
 $f_{MAX} = 50 \text{ MHz (TYP.) AT } V_{CC} = 5 \text{ V}$
- LOW POWER DISSIPATION
 $I_{CC} = 4 \mu\text{A (MAX.) AT } 25 \text{ }^\circ\text{C}$
- OUTPUT DRIVE CAPABILITY
 10 LSTTL LOADS
- BALANCED PROPAGATION DELAYS
 $t_{PLH} = t_{PHL}$
- SYMMETRICAL OUTPUT IMPEDANCE
 $I_{OH} = I_{OL} = 4 \text{ mA (MIN.)}$
- COMPATIBLE WITH TTL OUTPUTS
 $V_{IH} = 2 \text{ V (MIN.)}; V_{IL} = 0.8 \text{ V (MAX.)}$
- PIN AND FUNCTION COMPATIBLE
 WITH 54/74LS160 ~ 163

DESCRIPTION

M54/74HCT160 Decade, Asynchronous Clear
 M54/74HCT161 Binary, Asynchronous Clear
 M54/74HCT162 Decade, Synchronous Clear
 M54/74HCT163 Binary, Synchronous Clear

The M54/74HCT160, 161, 162 and 163 are high speed CMOS SYNCHRONOUS PRESETTABLE COUNTERS fabricated with silicon gate C²MOS technology. They have the same high speed operation similar to equivalent LSTTL while maintaining the CMOS low power dissipation.

The M54/74HCT160/162 are BCD Decade counters and the M54/74HCT161/163 are 4 bit binary counters. The **CLOCK** input is active on the rising edge. Both **LOAD** and **CLEAR** inputs are active Low.

Presetting of all four IC's is synchronous on the rising edge of the **CLOCK**. The function on the M54/74HCT162/163 is synchronous to **CLOCK**, while the M54/74HCT160/161 counters are cleared asynchronously. Two enable inputs (TE and PE) and **CARRY** output are provided to enable easy cascading of counters, which facilitates easy implementation of N-bit counters without using external gates. This integrated circuit has input and output characteristics that are fully compatible with 54/74 LSTTL logic families. M54/74HCT devices are designed to directly interface HSC²MOS systems with TTL and NMOS components. They are also plug in replacements for LSTTL devices giving a reduction of power consumption. All inputs are equipped with

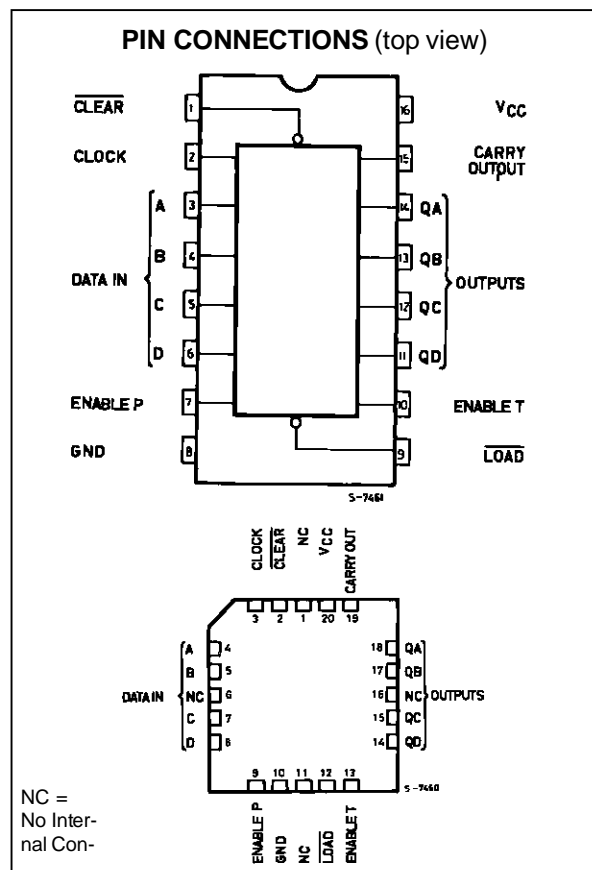
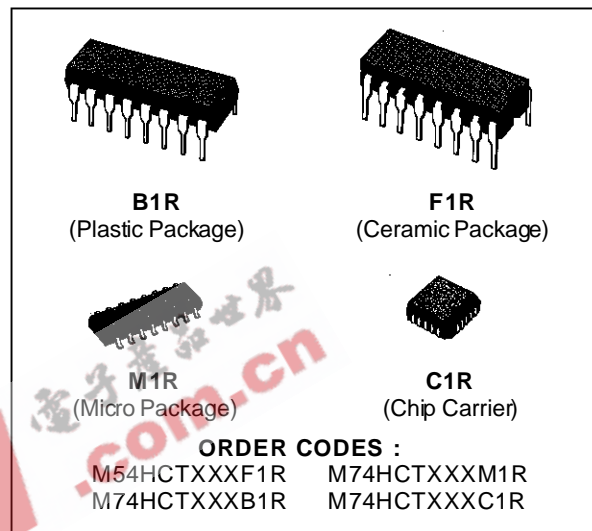

M54/M74HCT160/161/162/163

INPUT AND OUTPUT EQUIVALENT CIRCUIT

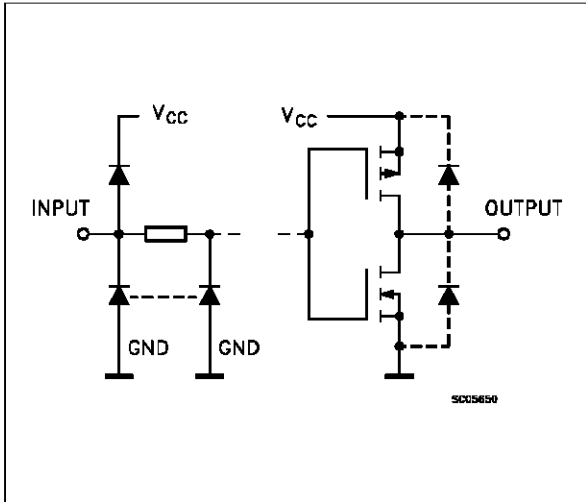

PIN DESCRIPTION

PIN No	SYMBOL	NAME AND FUNCTION
1	CLEAR	Master Reset
2	CLOCK	Clock Input (LOW to HIGH, Edge-triggered)
3, 4, 5, 6	A, B, C, D	Data Inputs
7	ENABLE P	Count Enable Input
10	ENABLET	Count Enable Carry Input
9	LOAD	Parallel Enable Input
14, 13, 12, 11	QA to QD	Flip Flop Outputs
15	CARRY OUTPUT	Terminal Count Output
8	GND	Ground (0V)
16	V _{CC}	Positive Supply Voltage

IEC LOGIC SYMBOL (HCT160)

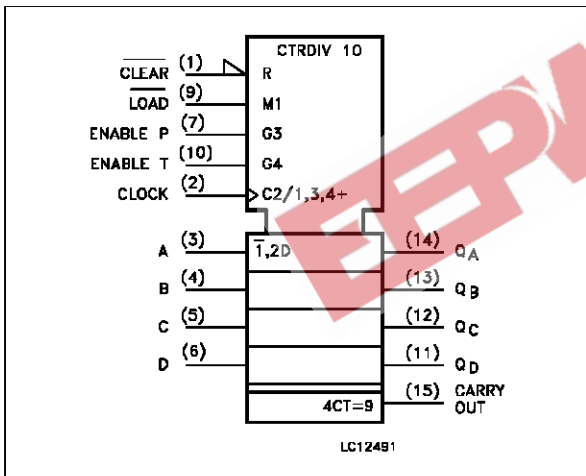

IEC LOGIC SYMBOL (HCT161)

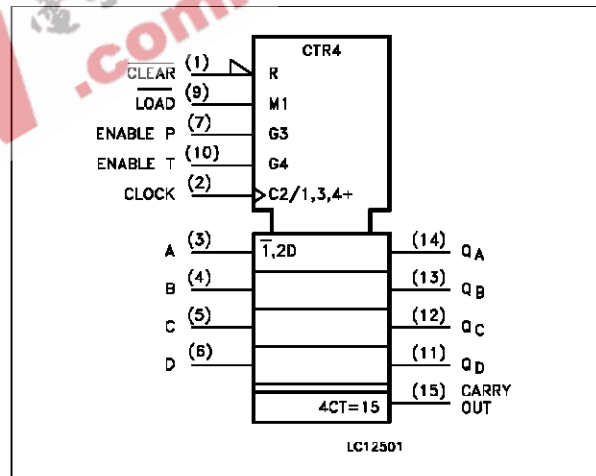

IEC LOGIC SYMBOL (HCT162)

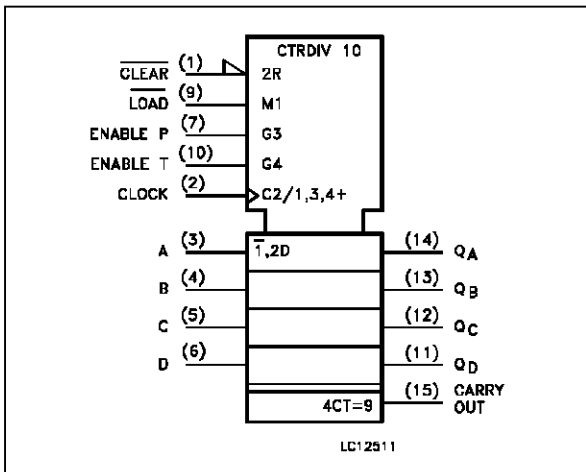

IEC LOGIC SYMBOL (HCT163)

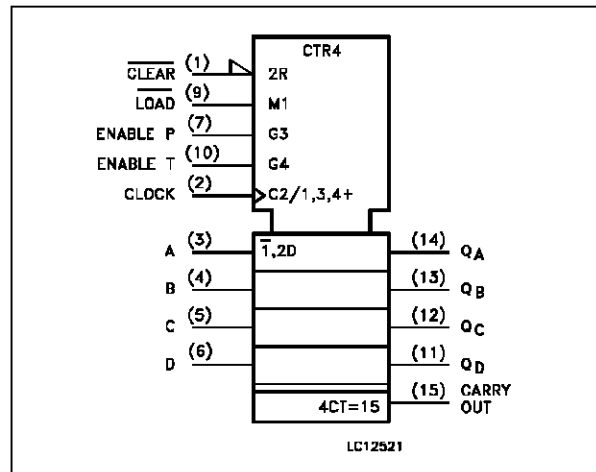

TRUTH TABLE

M54/74HCT160/161					M54/74HCT162/163					OUTPUTS				FUNCTION
INPUTS					INPUTS					QA	QB	QC	QD	
CLR	LD	PE	TE	CK	CLR	LD	PE	TE	CK					
L	X	X	X	X	L	X	X	X	┌	L	L	L	L	RESET TO "0"
H	L	X	X	┌	H	L	X	X	┌	A	B	C	D	PRESET DATA
H	H	X	L	┌	H	H	X	L	┌	NO CHANGE				NO COUNT
H	H	L	X	┌	H	H	L	X	┌	NO CHANGE				NO COUNT
H	H	H	H	┌	H	H	H	H	┌	COUNT UP				COUNT
H	X	X	X	┌	X	X	X	X	┌	NO CHANGE				NO COUNT

Note: X : Don't Care
 A, B, C, D : Logi level of data inputs
 Carry : $CARRY = TE \cdot Q_A \cdot Q_B \cdot \bar{Q}_C \cdot Q_D$ (M54/74HCT160/162)
 Carry : $CARRY = TE \cdot Q_A \cdot Q_B \cdot Q_C \cdot Q_D$ (M54/74HCT161/163)

TIMING CHART (HCT160/162 : decade counter)

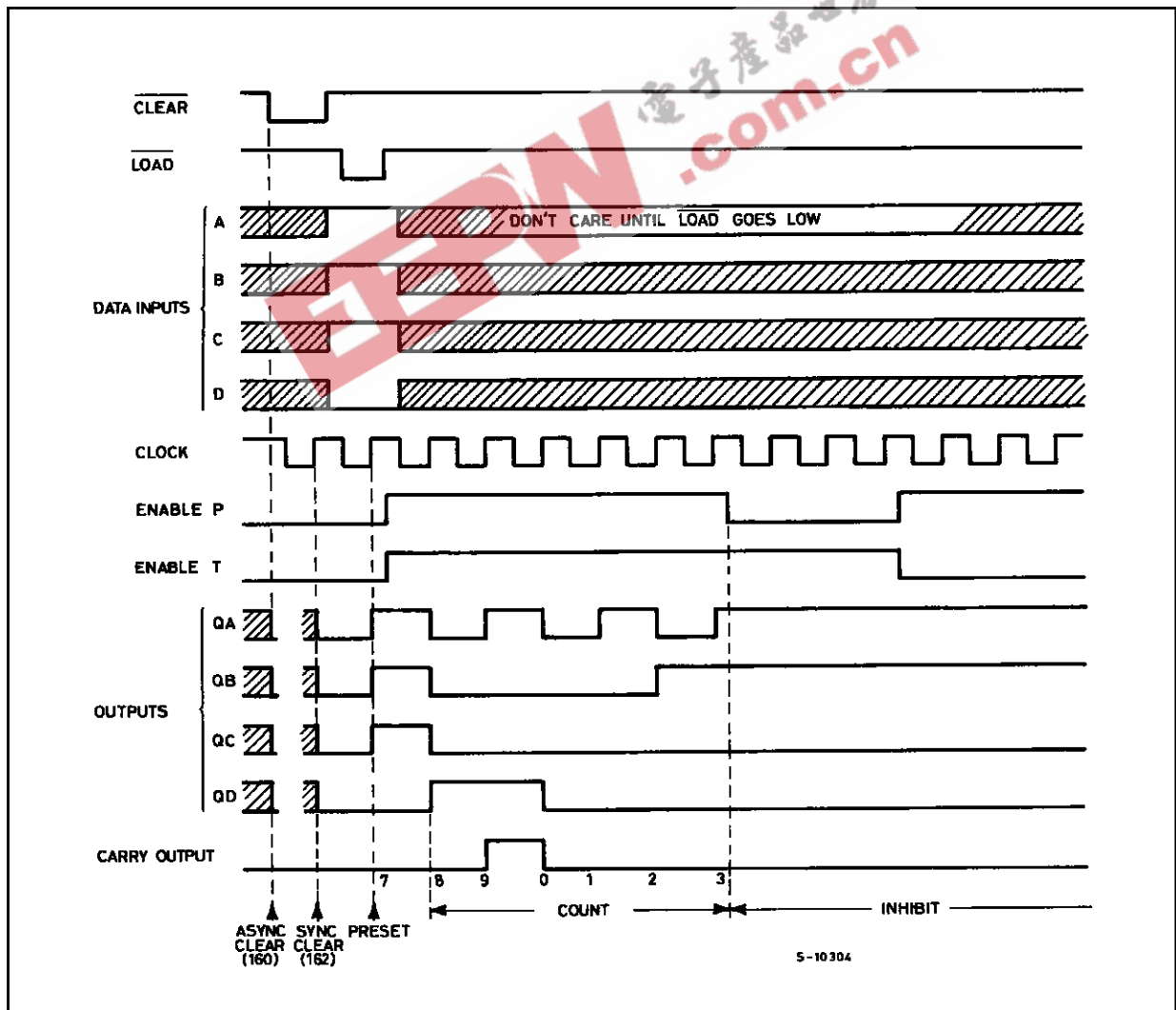

M54/M74HCT160/161/162/163

TIMING CHART (HCT161/163 : binary counter)

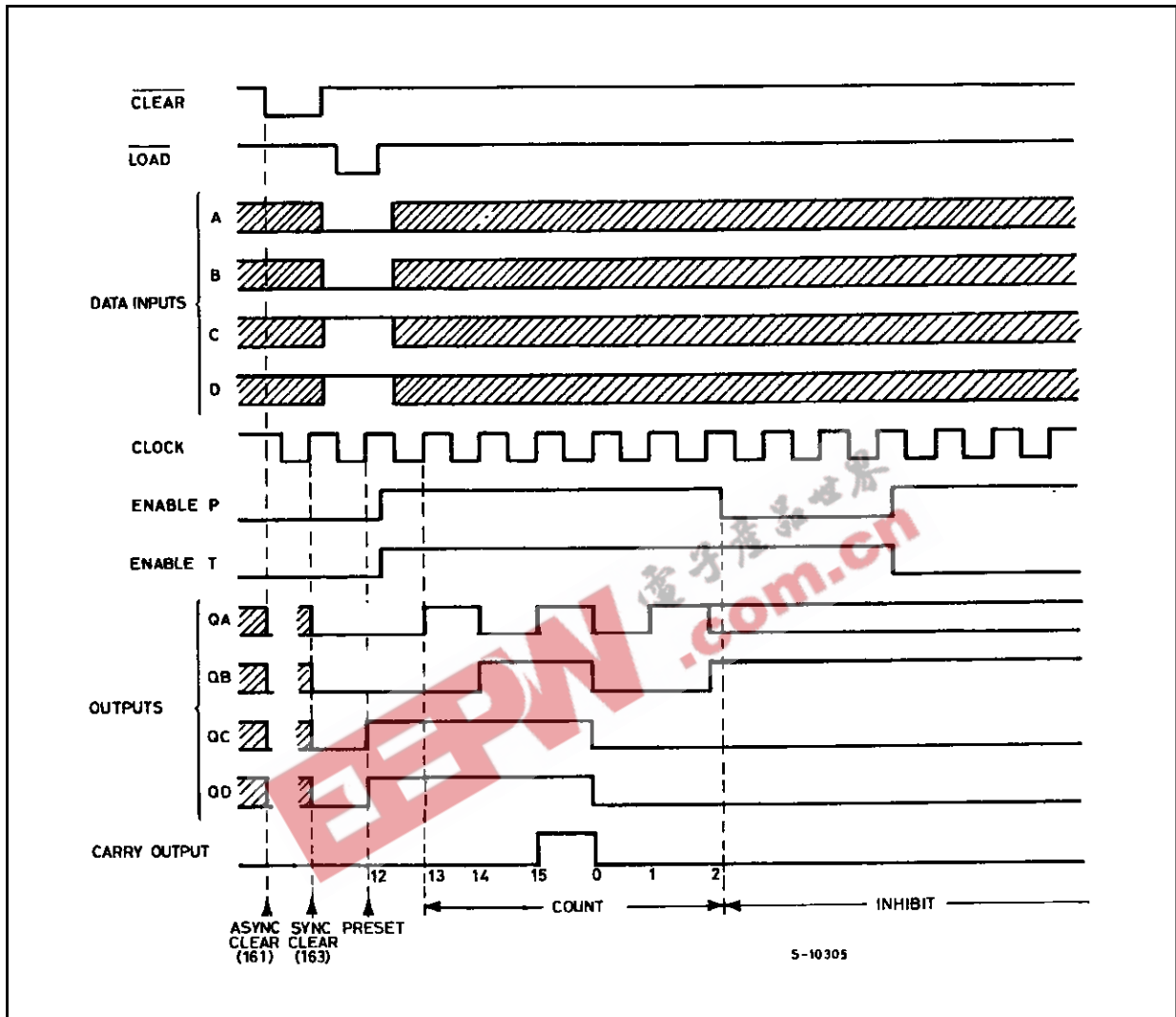

LOGIC DIAGRAM

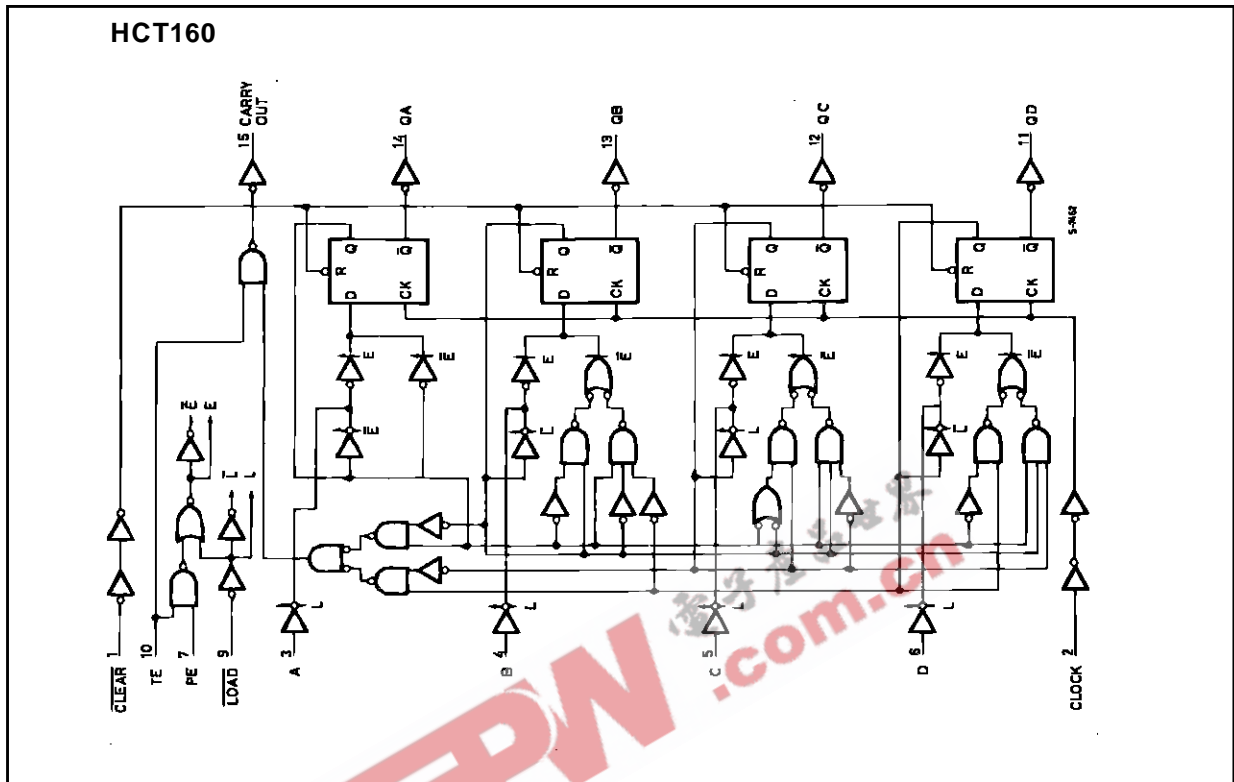

LOGIC DIAGRAM

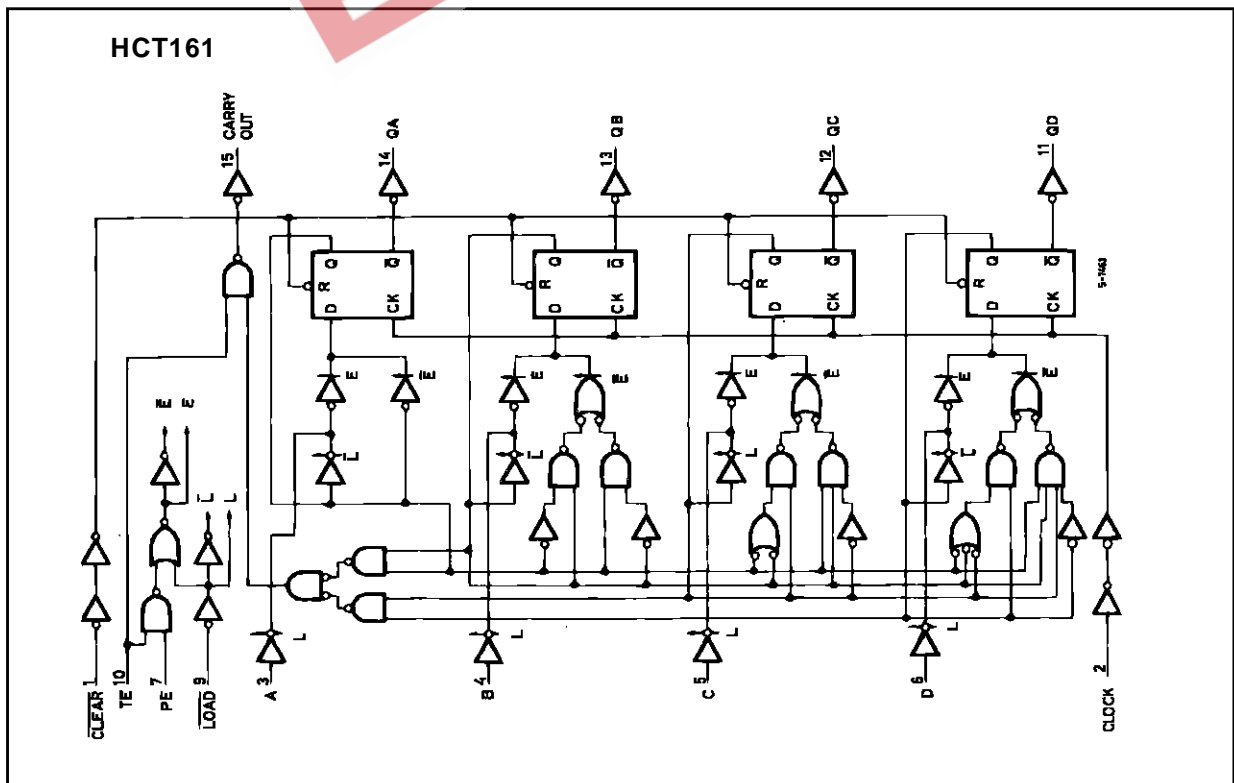

M54/M74HCT160/161/162/163

LOGIC DIAGRAM

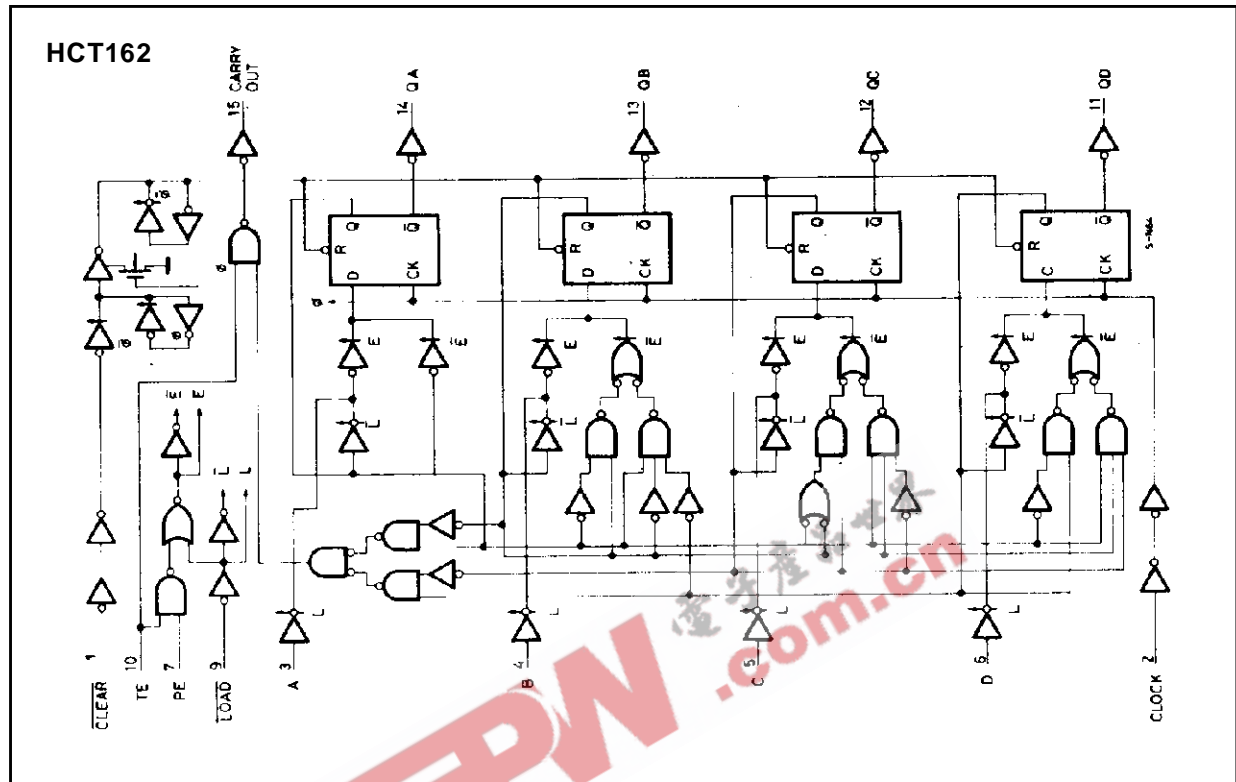

LOGIC DIAGRAM

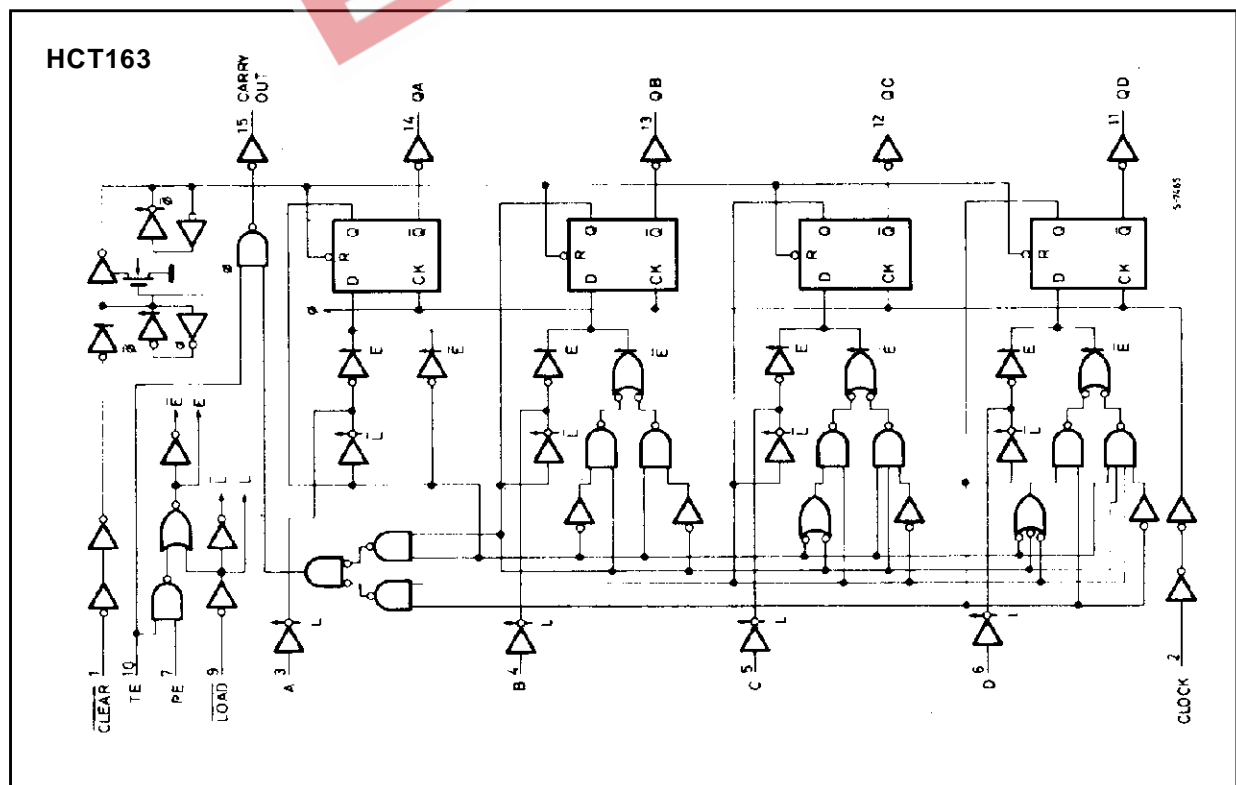

ABSOLUTE MAXIMUM RATINGS

Symbol	Parameter	Value	Unit
V _{CC}	Supply Voltage	-0.5 to +7	V
V _I	DC Input Voltage	-0.5 to V _{CC} + 0.5	V
V _O	DC Output Voltage	-0.5 to V _{CC} + 0.5	V
I _{IK}	DC Input Diode Current	± 20	mA
I _{OK}	DC Output Diode Current	± 20	mA
I _O	DC Output Source Sink Current Per Output Pin	± 25	mA
I _{CC} or I _{GND}	DC V _{CC} or Ground Current	± 50	mA
P _D	Power Dissipation	500 (*)	mW
T _{stg}	Storage Temperature	-65 to +150	°C
T _L	Lead Temperature (10 sec)	300	°C

Absolute Maximum Ratings are those values beyond which damage to the device may occur. Functional operation under these conditions is not implied.

(*) 500 mW: ≅ 65 °C derate to 300 mW by 10mW/°C: 65 °C to 85 °C

RECOMMENDED OPERATING CONDITIONS

Symbol	Parameter	Value	Unit
V _{CC}	Supply Voltage	4.5 to 5.5	V
V _I	Input Voltage	0 to V _{CC}	V
V _O	Output Voltage	0 to V _{CC}	V
T _{op}	Operating Temperature: M54HC Series M74HC Series	-55 to +125 -40 to +85	°C °C
t _r , t _f	Input Rise and Fall Time (V _{CC} = 4.5 to 5.5V)	0 to 500	ns

M54/M74HCT160/161/162/163

DC SPECIFICATIONS

Symbol	Parameter	Test Conditions		Value						Unit		
		V _{CC} (V)		T _A = 25 °C 54HC and 74HC			-40 to 85 °C 74HC		-55 to 125 °C 54HC			
				Min.	Typ.	Max.	Min.	Max.	Min.		Max.	
V _{IH}	High Level Input Voltage	4.5 to 5.5		2.0			2.0		2.0		V	
V _{IL}	Low Level Input Voltage	4.5 to 5.5				0.8		0.8		0.8	V	
V _{OH}	High Level Output Voltage	4.5	V _I = V _{IH} or V _{IL}	I _O = -20 μA	4.4	4.5		4.4		4.4		V
				I _O = -4.0 mA	4.18	4.31		4.13		4.10		
V _{OL}	Low Level Output Voltage	4.5	V _I = V _{IH} or V _{IL}	I _O = 20 μA		0.0	0.1		0.1		0.1	V
				I _O = 4.0 mA		0.17	0.26		0.33		0.4	
I _I	Input Leakage Current	5.5	V _I = V _{CC} or GND			±0.1		±1		±1	μA	
I _{CC}	Quiescent Supply Current	5.5	V _I = V _{CC} or GND			4		40		80	μA	
ΔI _{CC}	Additional worst case supply current	5.5	Per Input pin V _I = 0.5V or V _I = 2.4V Other Inputs at V _{CC} or GND			2.0		2.9		3.0	mA	

AC ELECTRICAL CHARACTERISTICS (C_L = 50 pF, Input t_r = t_f = 6 ns)

Symbol	Parameter	Test Conditions		Value						Unit	
		V _{CC} (V)		T _A = 25 °C 54HC and 74HC			-40 to 85 °C 74HC		-55 to 125 °C 54HC		
				Min.	Typ.	Max.	Min.	Max.	Min.		Max.
t _{TLH} t _{THL}	Output Transition Time	4.5			8	15		19		22	ns
t _{PLH} t _{PHL}	Propagation Delay Time (CK - Q)	4.5			23	36		45		54	ns
t _{PLH} t _{PHL}	Propagation Delay Time (CK-CO)	4.5			27	42		53		63	ns
t _{PLH}	Propagation Delay Time (TE-CO)	4.5			21	33		41		50	ns
t _{PLH}	Propagation Delay Time (CLEAR - Q)	4.5	for HCT160/161 only		26	40		50		60	ns
t _{PHL}	Propagation Delay Time (CLEAR-CO)	4.5	for HCT160/161 only		28	43		54		65	ns
f _{MAX}	Maximum Clock Frequency	4.5		31	49		25		21		MHz
t _{W(H)} t _{W(L)}	Minimum Pulse Width (CK)	4.5			8	15		19		22	ns
t _{W(L)}	Minimum Pulse Width (CLEAR)	4.5	for HCT160/161 only		8	15		19		22	ns
t _s	Minimum Set-up Time (LOAD, PE, TE)	4.5			11	20		25		30	ns
t _s	Minimum Set-up Time (A, B, C, D)	4.5			5	15		19		22	ns
t _s	Minimum Set-up Time (CLEAR)	4.5	for HCT162/163 only		5	15		19		22	ns
t _h	Minimum Hold Time	4.5				5		5		8	ns
t _{REM}	Minimum Removal Time (CLEAR)	4.5	for HCT160/161 only		5	15		19		22	ns
C _{IN}	Input Capacitance				5	10		10		10	pF
C _{PD} (*)	Power Dissipation Capacitance				33						pF

(*) C_{PD} is defined as the value of the IC's internal equivalent capacitance which is calculated from the operating current consumption without load. (Refer to Test Circuit). Average operating current can be obtained by the following equation. I_{CC(opr)} = C_{PD} • V_{CC} • f_{IN} + I_{CC}

SWITCHING CHARACTERISTICS TEST WAVEFORM

COUNT MODE

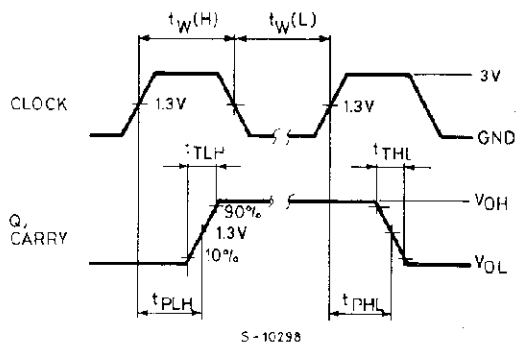

CLEAR MODE (HCT160/161)

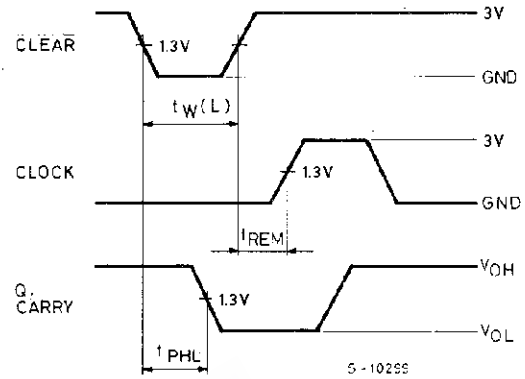

PRESET MODE

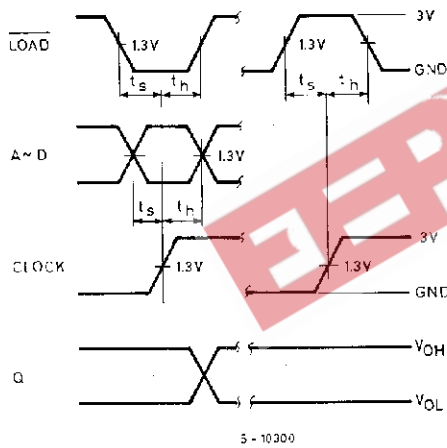

CLEAR MODE (HCT162/163)

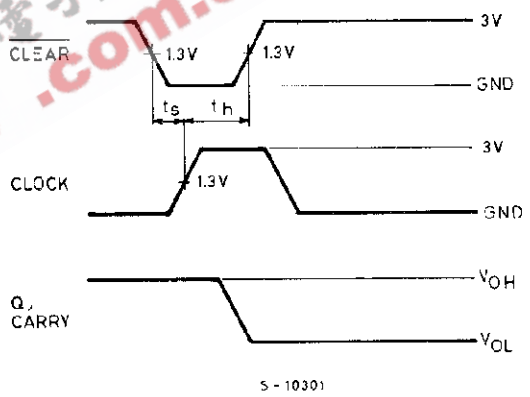

COUNTENABLE MODE

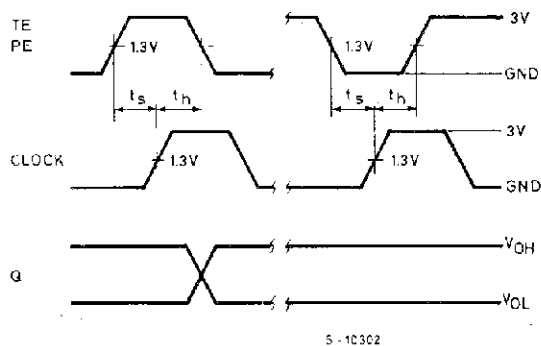

CASCADE MODE
(fix maximum count)

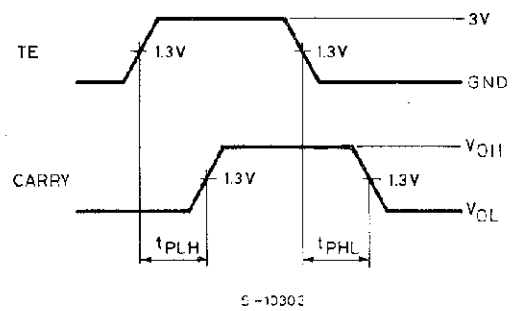

TEST CIRCUIT I_{cc} (Opr.)

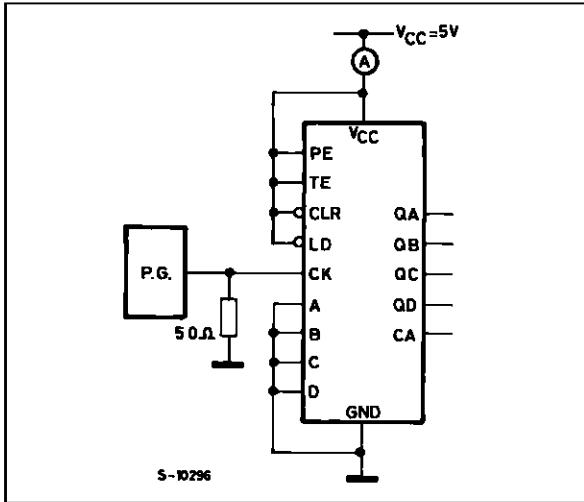

TOTAL OPERATING CURRENT WHEN USING A CAPACITIVE LOAD

When the outputs drive a capacitive load, the total current can be calculated as follows :

For M74HCT160/162 :

$$\Delta I_{cc} = f_{ck} \cdot V_{cc} \cdot \left(\frac{C_a}{2} + \frac{C_b}{5} + \frac{C_c}{10} + \frac{C_d}{10} + \frac{C_{ca}}{10} \right)$$

For M74HCT161/163 :

$$\Delta I_{cc} = f_{ck} \cdot V_{cc} \cdot \left(\frac{C_a}{2} + \frac{C_b}{4} + \frac{C_c}{8} + \frac{C_d}{16} + \frac{C_{ca}}{16} \right)$$

C_a to C_{ca} are the capacitors loading the outputs.

TYPICAL APPLICATION

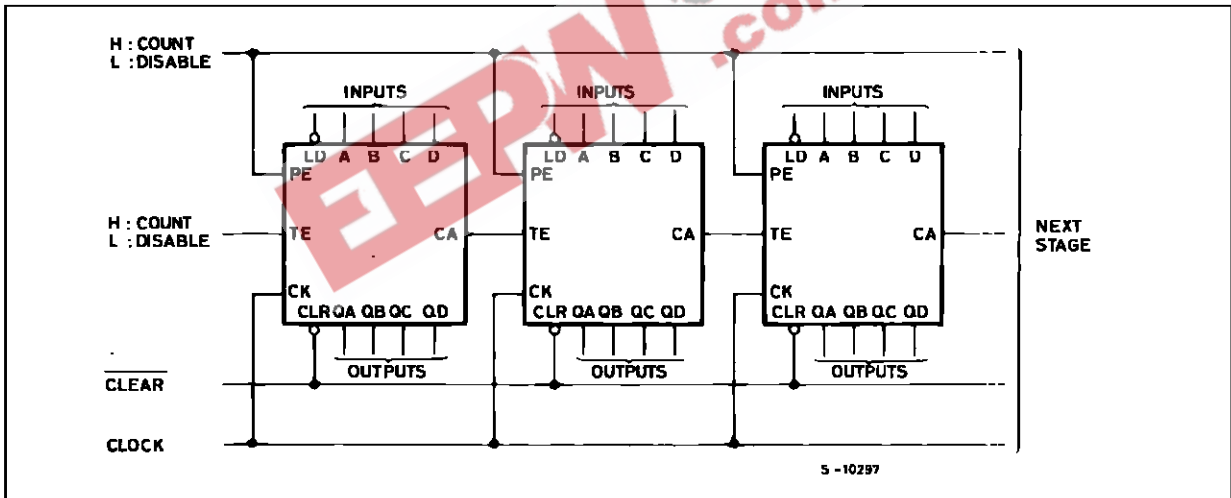

M54/M74HCT160/161/162/163

Plastic DIP16 (0.25) MECHANICAL DATA

DIM.	mm			inch		
	MIN.	TYP.	MAX.	MIN.	TYP.	MAX.
a1	0.51			0.020		
B	0.77		1.65	0.030		0.065
b		0.5			0.020	
b1		0.25			0.010	
D			20			0.787
E		8.5			0.335	
e		2.54			0.100	
e3		17.78			0.700	
F			7.1			0.280
I			5.1			0.201
L		3.3			0.130	
Z			1.27			0.050

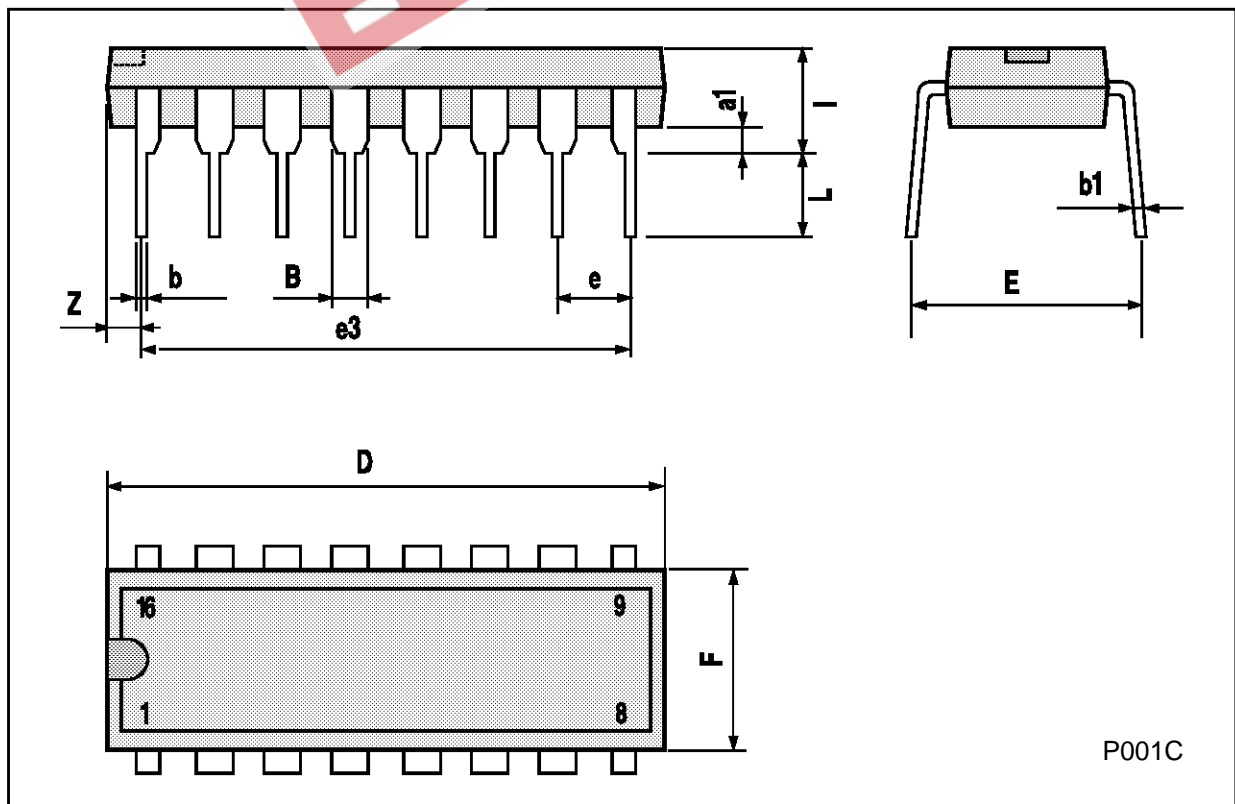

Ceramic DIP16/1 MECHANICAL DATA

DIM.	mm			inch		
	MIN.	TYP.	MAX.	MIN.	TYP.	MAX.
A			20			0.787
B			7			0.276
D		3.3			0.130	
E	0.38			0.015		
e3		17.78			0.700	
F	2.29		2.79	0.090		0.110
G	0.4		0.55	0.016		0.022
H	1.17		1.52	0.046		0.060
L	0.22		0.31	0.009		0.012
M	0.51		1.27	0.020		0.050
N			10.3			0.406
P	7.8		8.05	0.307		0.317
Q			5.08			0.200

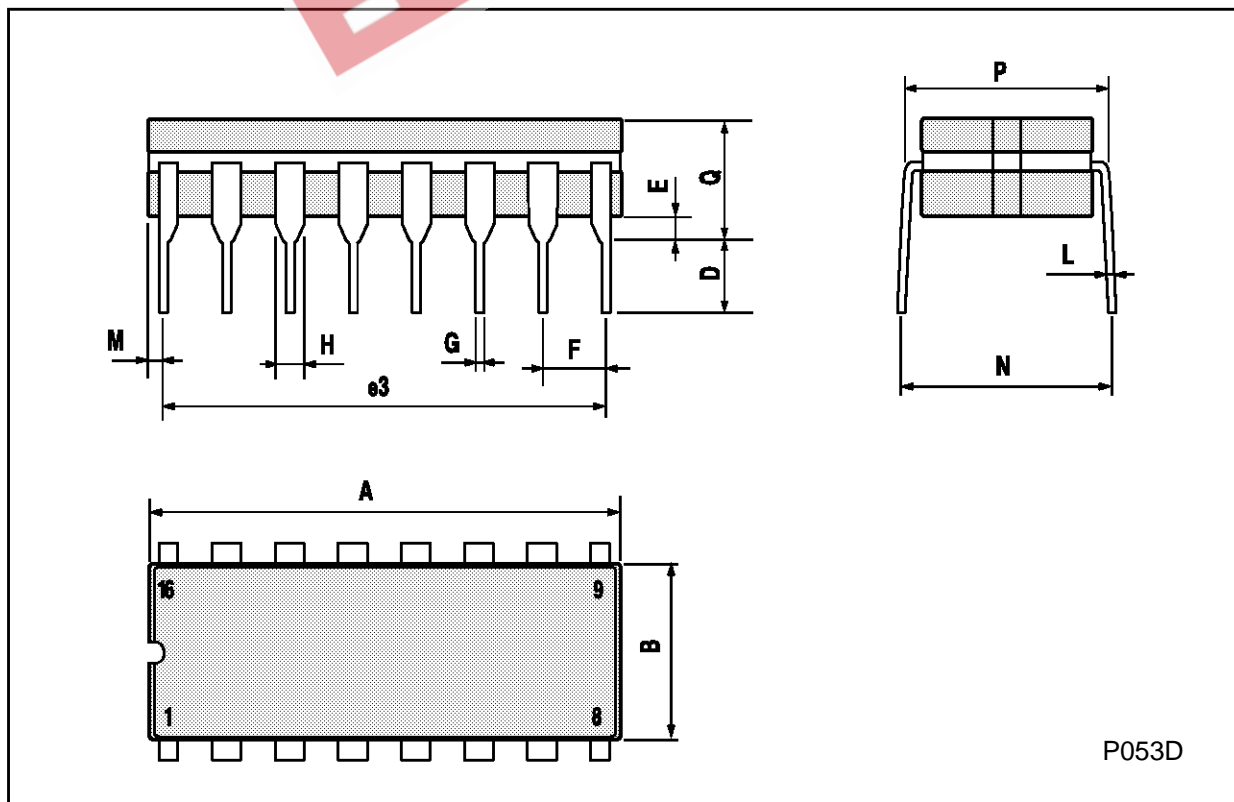

SO16 (Narrow) MECHANICAL DATA

DIM.	mm			inch		
	MIN.	TYP.	MAX.	MIN.	TYP.	MAX.
A			1.75			0.068
a1	0.1		0.2	0.004		0.007
a2			1.65			0.064
b	0.35		0.46	0.013		0.018
b1	0.19		0.25	0.007		0.010
C		0.5			0.019	
c1	45° (typ.)					
D	9.8		10	0.385		0.393
E	5.8		6.2	0.228		0.244
e		1.27			0.050	
e3		8.89			0.350	
F	3.8		4.0	0.149		0.157
G	4.6		5.3	0.181		0.208
L	0.5		1.27	0.019		0.050
M			0.62			0.024
S	8° (max.)					

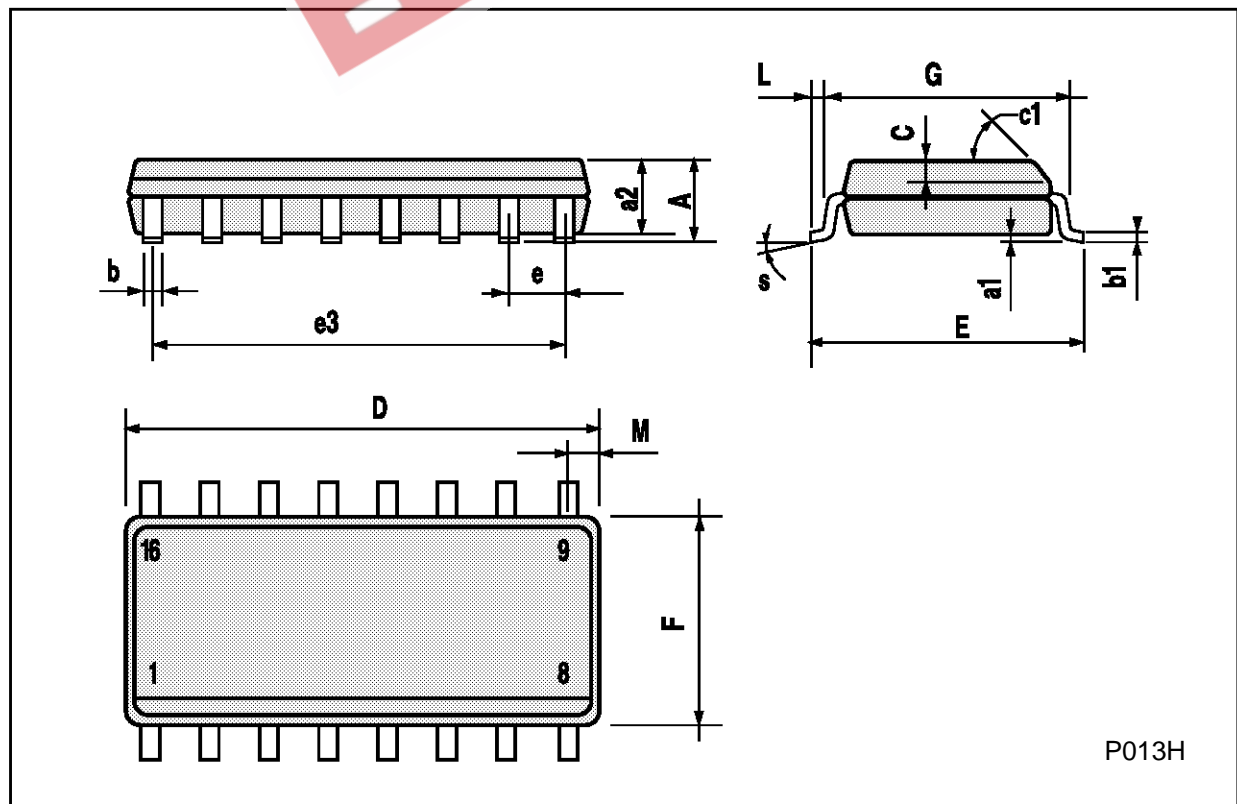

PLCC20 MECHANICAL DATA

DIM.	mm			inch		
	MIN.	TYP.	MAX.	MIN.	TYP.	MAX.
A	9.78		10.03	0.385		0.395
B	8.89		9.04	0.350		0.356
D	4.2		4.57	0.165		0.180
d1		2.54			0.100	
d2		0.56			0.022	
E	7.37		8.38	0.290		0.330
e		1.27			0.050	
e3		5.08			0.200	
F		0.38			0.015	
G			0.101			0.004
M		1.27			0.050	
M1		1.14			0.045	

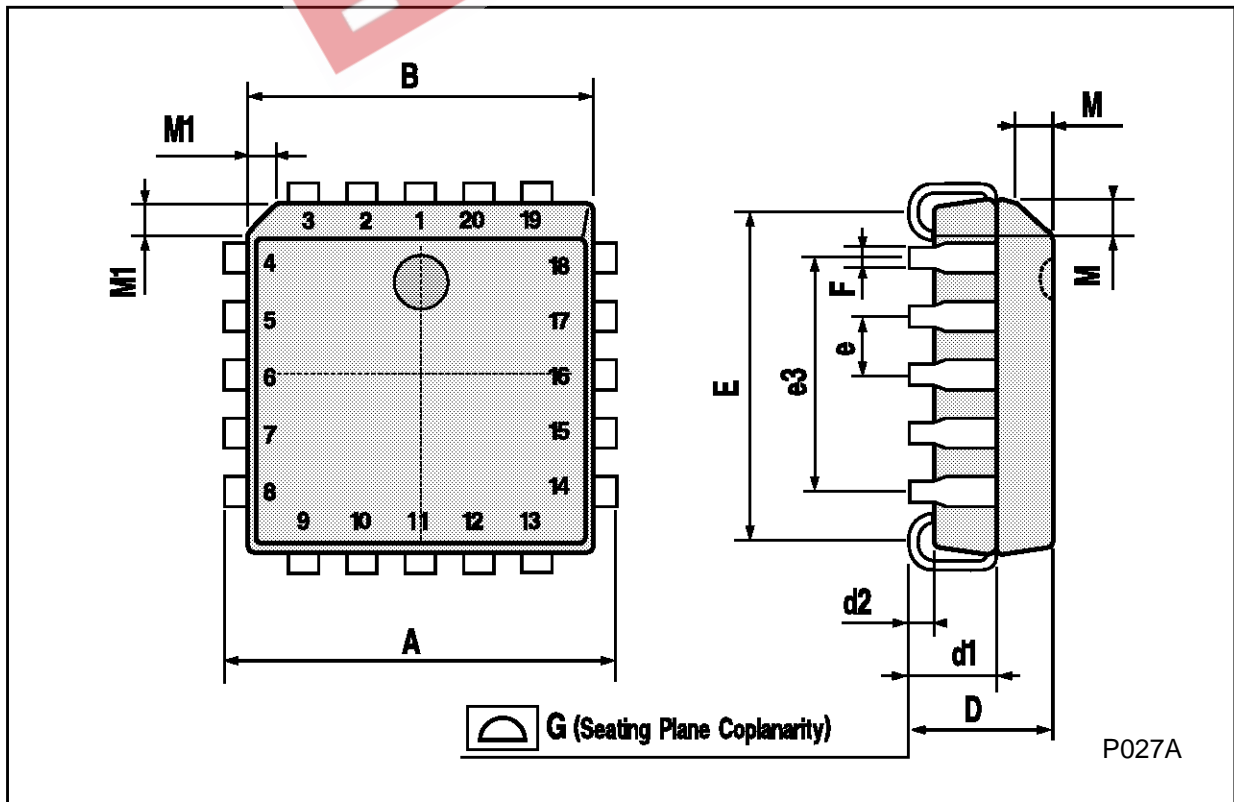

EEPW 电子產品世界
.com.cn

Information furnished is believed to be accurate and reliable. However, SGS-THOMSON Microelectronics assumes no responsibility for the consequences of use of such information nor for any infringement of patents or other rights of third parties which may result from its use. No license is granted by implication or otherwise under any patent or patent rights of SGS-THOMSON Microelectronics. Specifications mentioned in this publication are subject to change without notice. This publication supersedes and replaces all information previously supplied. SGS-THOMSON Microelectronics products are not authorized for use as critical components in life support devices or systems without express written approval of SGS-THOMSON Microelectronics.

© 1994 SGS-THOMSON Microelectronics - All Rights Reserved

SGS-THOMSON Microelectronics GROUP OF COMPANIES
Australia - Brazil - France - Germany - Hong Kong - Italy - Japan - Korea - Malaysia - Malta - Morocco - The Netherlands -
Singapore - Spain - Sweden - Switzerland - Taiwan - Thailand - United Kingdom - U.S.A