

LM2403 Monolithic Triple 4.5 nS CRT Driver

General Description

The LM2403 is an integrated high voltage CRT driver circuit designed for use in high resolution color monitor applications. The IC contains three high input impedance, wide band amplifiers which directly drive the RGB cathodes of a CRT. Each channel has its gain internally set to -14 and can drive CRT capacitive loads as well as resistive loads presented by other applications, limited only by the package's power dissipation.

The IC is packaged in an industry standard 11 lead TO-220 molded plastic power package. See thermal considerations on page 5.

Features

- Rise/fall times typically 4.5 nS with 8 pF load at 40 V_{pp}
- Well matched with LM1283 video preamp
- Output swing capability: 60 V_{pp} for $V_{CC} = 80V$
- 1V to 5V input range
- Stable with 0 pF–20 pF capacitive loads and inductive peaking networks
- Convenient TO-220 staggered lead package style
- Standard LM240X Family Pinout which is designed for easy PCB layout

Applications

- CRT driver for color monitors with display resolutions up to 1600 x 1200
- Pixel clock frequency up to 160 MHz

Schematic and Connection Diagrams

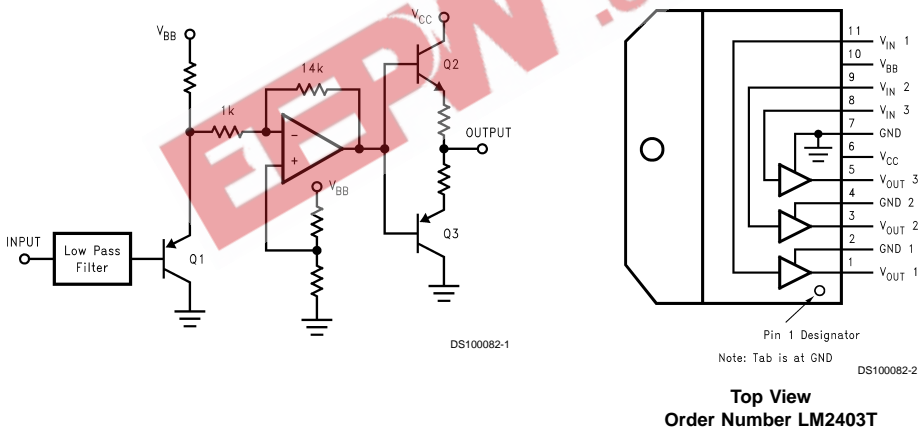

FIGURE 1. Simplified Schematic Diagram (One Channel)

Absolute Maximum Ratings (Notes 1, 2)

If Military/Aerospace specified devices are required, please contact the National Semiconductor Sales Office/Distributors for availability and specifications.

Supply Voltage (V_{CC})	+90V
Bias Voltage (V_{BB})	+16V
Input Voltage (V_{IN})	-0.5V to $V_{BIAS} + 0.5V$
Storage Temperature Range (T_{STG})	-65°C to +150°C
Lead Temperature	
(Soldering, <10 sec.)	300°C
ESD Tolerance, Human Body Model	2 kV
Machine Model	250V

Operating Range (Note 3)

V_{CC}	+60V to +85V
V_{BB}	+8V to +15V
V_{IN}	+1V to +5V
V_{OUT}	+10V to +70V
Case Temperature	-20°C to +100°C

Do not operate the part without a heat sink.

Note 1: Absolute Maximum Ratings indicate limits beyond which damage to the device may occur.

Note 2: All voltages are measured with respect to GND, unless otherwise specified.

Note 3: Operating ratings indicate conditions for which the device is functional, but do not guarantee specific performance limits. For guaranteed specifications and test conditions, see the Electrical Characteristics. The guaranteed specifications apply only for the test conditions listed. Some performance characteristics may change when the device is not operated under the listed test conditions.

Electrical Characteristics

(See Figure 2 for Test Circuit)

Unless otherwise noted: $V_{CC} = +80V$, $V_{BB} = +12V$, $V_{IN} = +3.3V_{DC}$, $C_L = 8pF$, $L_P = 0.22\mu H$, Output = 40 V_{PP} at 1 MHz, $T_A = 25^\circ C$.

Symbol	Parameter	Condition	LM2403			Units
			Min	Typical	Max	
I_{CC}	Supply Current	Per Channel, No Output Load		26		mA
I_{BB}	Bias Current	All Three Channels		11.5		mA
V_{OUT}	DC Output Voltage	No AC Input Signal, $V_{IN} = 2.8V$	48	52	56	V_{DC}
A_V	DC Voltage Gain	No AC Input Signal	-12	-14	-16	
ΔA_V	Gain Matching	(Note 4), No AC Input Signal		1.0		dB
LE	Linearity Error	(Notes 4, 5), No AC Input Signal		3.5		%
t_R	Rise Time	10% to 90%		4.5		nS
t_F	Fall Time	90% to 10%		4.5		nS
OS	Overshoot			3		%

Note 4: Calculated value from Voltage Gain test on each channel.

Note 5: Linearity Error is the variation in dc gain from $V_{IN} = 1.5V$ to $V_{IN} = 5V$.

Note 6: Input from signal generator: $t_r, t_f < 1nS$.

AC Test Circuit

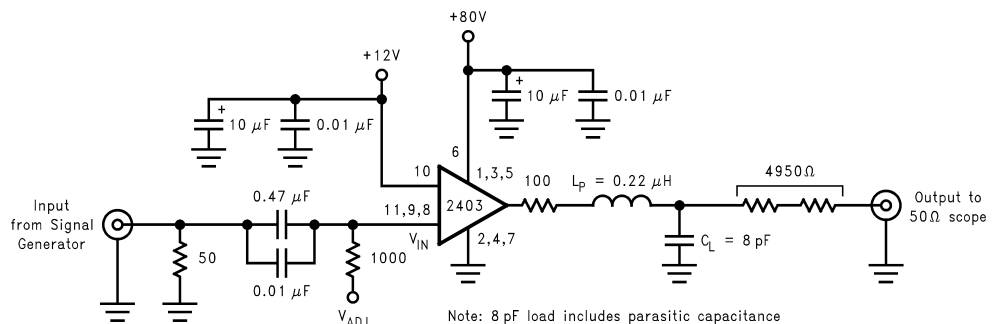

FIGURE 2. Test Circuit (One Channel)

Figure 2 shows a typical test circuit for evaluation of the LM2403. This circuit is designed to allow testing of the LM2403 in a 50Ω environment without the use of an expensive FET probe. The 4950Ω resistor at the output forms a 100:1 voltage divider when connected to a 50Ω load.

AC Test Circuit (Continued)

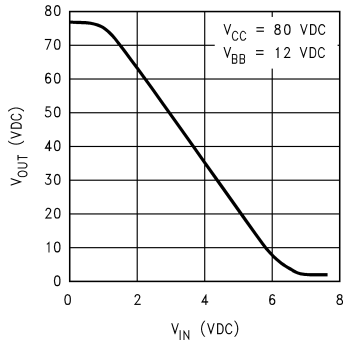

FIGURE 3. V_{OUT} vs V_{IN}

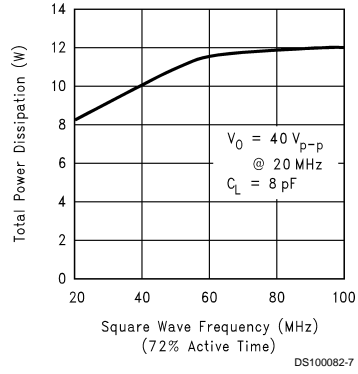

FIGURE 6. Power Dissipation vs Frequency

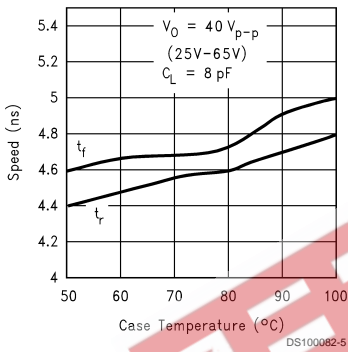

FIGURE 4. Speed vs Temp.

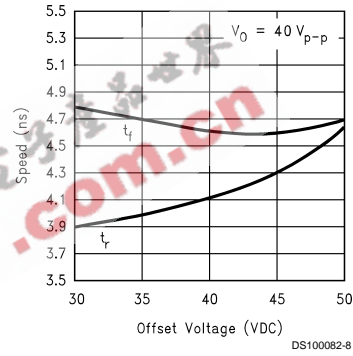

FIGURE 7. Speed vs Offset

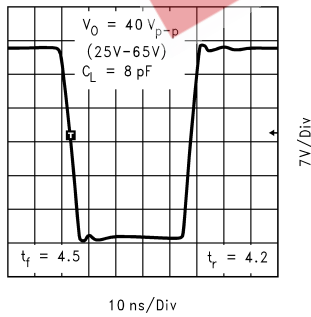

FIGURE 5. Pulse Response

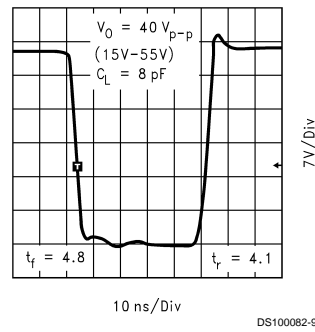

FIGURE 8. Pulse Response with $V_{CC} = 70$ V_{DC}

Theory of Operation

The LM2403 is a high voltage monolithic three channel CRT driver suitable for high resolution display applications. The LM2403 operates using 80V and 12V power supplies. The part is housed in the industry standard 11-lead TO-220 molded plastic power package.

The simplified circuit diagram of the LM2403 is shown in *Figure 1*. A PNP emitter follower, Q1, provides input buffering. The 14 k Ω feedback resistor and the 1 k Ω input resistor sets the gain of the inverting op-amp to -14. Emitter followers Q2 and Q3 isolate the output of the feedback amplifier from the capacitance of the CRT cathode, and make the circuit relatively insensitive to load capacitance.

Figure 2 shows a typical test circuit for evaluation of the LM2403. This circuit is designed to allow testing of the LM2403 in a 50 Ω environment without the use of an expensive FET probe. In this test circuit, two low inductance resistors in series totaling 4.95 k Ω form a 100:1 wideband low capacitance probe when connected to a 50 Ω cable and load. The input signal from the generator is ac coupled to the base of Q1.

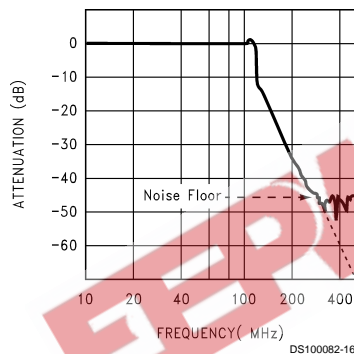

FIGURE 9.

Figure 9 shows the large signal sine wave frequency response of the LM2403. The frequency response rolls off very rapidly above the bandwidth limit of the amplifier. There are two reasons for this fast response roll-off:

1. The LM2403 contains an input low pass filter to help remove unwanted high frequency harmonics that can cause EMI problems. This filter does not significantly affect the rise and fall times of the signal as it operates above the -3 dB bandwidth of the device.
2. The internal feedback network of the closed loop amplifier holds the gain at -14 until the loop gain drops below unity. Above this frequency, the amplifier response falls with the open loop gain of the amplifier, as the feedback ceases to have any significant effect. There is also a change in the impedance match between the op-amp and the emitter follower output stage with large signals at higher frequencies. This creates a gain boost that extends the bandwidth, then gives a sudden roll off as shown in *Figure 9*. The exact response of this roll off may vary slightly depending upon operating conditions, signal amplitude etc.

In both cases, the fast roll of the high frequency harmonics will help to limit the creation of high frequency EMI harmonics, without limiting video rise and fall time characteristics. However, due to the very fast switching speeds of the de-

vice, good layout design for EMI is CRITICAL. Path lengths and loop areas of the video signals must be kept to a minimum.

Application Hints

INTRODUCTION

National Semiconductor (NSC) is committed to providing application information that assists our customers in obtaining the best performance possible from our products. The following information is provided in order to support this commitment. The reader should be aware that the optimization of performance was done using a specific printed circuit board designed at NSC. Variations in performance can be realized due to physical changes in the printed circuit board and the application. Therefore, the designer should know that component value changes may be required in order to optimize performance in a given application. The values shown in this document can be used as a starting point for evaluation purposes. When working with high bandwidth circuits, good layout practices are also critical to achieving maximum performance.

POWER SUPPLY BYPASS

Since the LM2403 is a high bandwidth amplifier, proper power supply bypassing is critical for optimum performance. Improper power supply bypassing can result in large overshoot, ringing and oscillation. A 0.1 μ F capacitor should be connected from the supply pin, Vcc, to ground, as close to the supply and ground pins as is practical. Additionally, a 10 μ F to 100 μ F electrolytic capacitor should be connected from the supply pin to ground. The electrolytic capacitor should also be placed reasonably close to the LM2403's supply and ground pins. A 0.1 μ F capacitor should be connected from the bias pin, Vbb, to ground, as close as is practical to the part.

ARC PROTECTION

During normal CRT operation, internal arcing may occasionally occur. Spark gaps, in the range of 200V, connected from the CRT cathodes to CRT ground will limit the maximum voltage, but to a value that is much higher than allowable on the LM2403. This fast, high voltage, high energy pulse can damage the LM2403 output stage. The application circuit shown in *Figure 10* is designed to help clamp the voltage at the output of the LM2403 to a safe level. The clamp diodes should have a fast transient response, high peak current rating, low series impedance and low shunt capacitance. FDH400 or equivalent diodes are recommended. D1 and D2 should have short, low impedance connections to V_{CC} and ground respectively. The cathode of D1 should be located very close to a separately decoupled bypass capacitor. The ground connection of the diode and the decoupling capacitor should be very close to the LM2403 ground. This will significantly reduce the high frequency voltage transients that the LM2403 would be subjected to during an arcover condition. Resistor R2 limits the arcover current that is seen by the diodes while R1 limits the current into the LM2403 as well as the voltage stress at the outputs of the device. R2 should be a 1/2W solid carbon type resistor. R1 can be a 1/4W metal or carbon film type resistor. Inductor L1 is critical to reduce the initial high frequency voltage levels that the LM2403 would be subjected to. Having large value resistors for R1 and R2 would be desirable, but this has the effect of increasing rise and fall times. The inductor will not only help protect the device but it

Application Hints (Continued)

will also help optimize rise and fall times as well as minimize EMI. For proper arc protection, it is important to not omit any of the arc protection components shown in Figure 10.

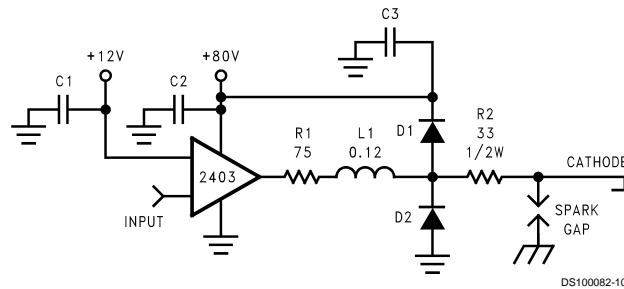

FIGURE 10. One Channel of the LM2403 with the Recommended Arc Protection Circuit

OPTIMIZING TRANSIENT RESPONSE

Referring to Figure 10, there are three components (R1, R2 and L1) that can be adjusted to optimize the transient response of the application circuit. Increasing the values of R1 and R2 will slow the circuit down while decreasing overshoot. Increasing the value of L1 will speed up the circuit as well as increase overshoot. It is very important to use inductors with very high self-resonant frequencies, preferably above 300 MHz. Ferrite core inductors from J.W. Miller Magnetics (part # 78FR12M) were used for optimizing the performance of the device in the NSC application board. The values shown in Figure 10 can be used as a good starting point for the evaluation of the LM2403. The NSC demo board also has a position open to add a resistor in parallel with L1. This resistor can be used to help control overshoot. Using variable resistors for R1 and the parallel resistor is a great way to help dial in the values needed for optimum performance in a given application.

Pull-up Resistors

Optimizing the performance of the LM2403 does require the use of pull-up resistors at the outputs of the CRT driver. These resistors are shown as R100, R101, and R102 in the schematic. If you have a demo board from National please note that these resistors have been added on the back of the board since there is no PCB location for the pull-up resistors. Because of the improved performance with these resistors, all demo boards have been shipped with the added pull-up resistors. The LM2403 does have some crossover distortion, normal for any AB amplifier such as the LM2403. Adding the pull-up resistors does add more bias to Q3 (Figure 1) thus minimizing the crossover distortion. The LM2403 is normally used in high end monitors, so it is highly recommended that the 12k pull-up resistors be used in any design using the LM2403. Selecting a 12k resistor provides the needed pull-up current and limits the worst case power dissipation to 1/4W (white level at 25V).

In some applications pull-down resistors may be preferred. Using 12k resistors gives acceptable performance, but this will require the use of 1/2W resistors. Normally the power save mode establishes whether pull-up or pull-down resistors are preferred. If the setup of the power save mode in the monitor gives a low output at the LM2403, then the pull-down resistors would be preferred, if the 80V supply is still turned on.

Effect of Load Capacitance

The output rise and fall times as well as overshoot will vary as the load capacitance varies. The values of the output circuit (R1, R2 and L1 in Figure 10) should be chosen based on the nominal load capacitance. Once this is done the performance of the design can be checked by varying the load based on what the expected variation will be.

For example, suppose you needed to drive a 10 pF ($\pm 20\%$) load with a 40V_{p-p} waveform. First, you would pick the values of R1, R2 and L1 that give the desired response with a 10 pF load. Then you would test the design when driving an 8 pF load and a 12 pF load. The table below summarizes the results from doing this exercise in a test board in the NSC lab. The output signal swing was 40V_{p-p} from 65V to 25V.

Parameter	8 pF	10 pF	12 pF
Rise Time	4.1	4.2	4.3
Overshoot	1%	5%	10%
Fall Time	4.4	4.6	4.7
Overshoot	1%	2%	5%

The example above clearly demonstrates the importance of having a good estimate of the range of the load capacitance.

Effect of Offset

Figure 7 shows the variation in rise and fall times when the output offset of the device is varied from 30 V_{DC} to 50 V_{DC}. The rise time shows about twice as much variation as the fall time, however the maximum variation relative to the center data point (40 V_{DC}) is less than 10%.

Operation with V_{CC} = 70V

The closed loop topography of the LM2403 allows operation down to 10V above ground. If the user can limit the white level between 10V and 20V, then operation with V_{CC} = 70V is possible. Operating the LM2403 with V_{CC} = 70V will require the same current even though the supply voltage has dropped by 12.5%. This results in a power savings of 12.5% (as high as 1.5W), allowing a reduction in the size of the heat-sink. Figure 8 shows the output waveform of the LM2403 operating at a white level of 15V, and a peak-to-peak output swing of 40V. Below is a summary of the LM2403 rise and fall times with various output offset levels with V_{CC} = 70V.

Application Hints (Continued)

Output Swing	Rise Time	Fall Time
10V–50V	4.0 ns	5.0 ns
15V–55V	4.2 ns	4.8 ns
20V–60V	4.4 ns	5.0 ns

THERMAL CONSIDERATIONS

Figure 4 shows the performance of the LM2403 in the test circuit shown in Figure 2 as a function of case temperature. The figure shows that the speed of the LM2403 decreases by less than 10% as the case temperature increases from 50°C to 100°C. This corresponds to a speed degradation of 2% for every 10°C rise in case temperature.

Figure 6 shows the total power dissipation of the LM2403 vs. Frequency when all three channels of the device are driving an 8 pF load with a 40V_{p-p} signal. The graph assumes a 72% active time (device operating at the specified frequency) which is typical in a monitor application. The other 28% of the time the device is assumed to be sitting at the black level (65V in this case). This graph gives the designer the information needed to determine the heat sink requirement for his application. The designer should note that if the load capacitance is increased the AC component of the total power dissipation will also increase.

The LM2403 case temperature must be maintained below 100°C. If the maximum expected ambient temperature is 50°C and the maximum power dissipation is 12W, then a maximum heat sink thermal resistance can be calculated:

$$R_{TH} = \frac{100^{\circ}\text{C} - 50^{\circ}\text{C}}{12\text{W}} = 4.17^{\circ}\text{C}/\text{W}$$

This example assumes a capacitive load of 8 pF and no resistive load.

TYPICAL APPLICATION

A typical application of the LM2403 is shown in Figure 11. Used in conjunction with an LM1283, a complete video channel from monitor input to CRT cathode can be achieved. Performance is satisfactory for resolutions up to 1600 x 1200 and pixel clock frequencies up to 160 MHz. Figure 11 is the schematic for the NSC demonstration board that can be used to evaluate the LM1283/2403 combination in a monitor.

PC Board Layout Considerations

For optimum performance, an adequate ground plane, isolation between channels, good supply bypassing and minimizing unwanted feedback are necessary. Also, the length of the signal traces from the preamplifier to the LM2403 and from the LM2403 to the CRT cathode should be as short as possible. The following references are recommended:

Ott, Henry W., "Noise Reduction Techniques in Electronic Systems", John Wiley & Sons, New York, 1976.

"Guide to CRT Video Design", National Semiconductor Application Note 861.

"Video Amplifier Design for Computer Monitors", National Semiconductor Application Note 1013.

Pease, Robert A., "Troubleshooting Analog Circuits", Butterworth-Heinemann, 1991.

Because of its high small signal bandwidth, the part may oscillate in a monitor if feedback occurs around the video channel through the chassis wiring. To prevent this, leads to the video amplifier input circuit should be shielded, and input circuit wiring should be spaced as far as possible from output circuit wiring.

NSC Demonstration Board

Figures 12, 13 show routing and component placement on the NSC LM1283/2403 demonstration board. The schematic of the board is shown in Figure 11. This board provides a good example of a layout that can be used as a guide for future layouts. Note the location of the following components:

- C79 — V_{CC} bypass capacitor, located very close to pin 6 and ground pins
- C55 — V_{BB} bypass capacitor, located close to pin 10 and ground
- C75–C77 — V_{CC} bypass capacitors, near LM2403 and V_{CC} clamp diodes. Very important for arc protection

The routing of the LM2403 outputs to the CRT is very critical to achieving optimum performance. Figure 14 shows the routing and component placement from pin 1 to the blue cathode. Note that the components are placed so that they almost line up from the output pin of the LM2403 to the blue cathode pin of the CRT connector. This is done to minimize the length of the video path between these two components. Note also that D7, D8, R32 and D3 are placed to minimize the size of the video nodes that they are attached to. This minimizes parasitic capacitance in the video path and also enhances the effectiveness of the protection diodes. The anode of protection diode D8 is connected directly to a section of the the ground plane that has a short and direct path to the LM2403 ground pins. The cathode of D7 is connected to V_{CC} very close to decoupling capacitor C77 (see Figure 14) which is connected to the same section of the ground plane as D8. The diode placement and routing is very important for minimizing the voltage stress on the LM2403 during an arc over event. Lastly, notice that S1 is placed very close to the blue cathode and is tied directly to CRT ground.

Application Hints (Continued)

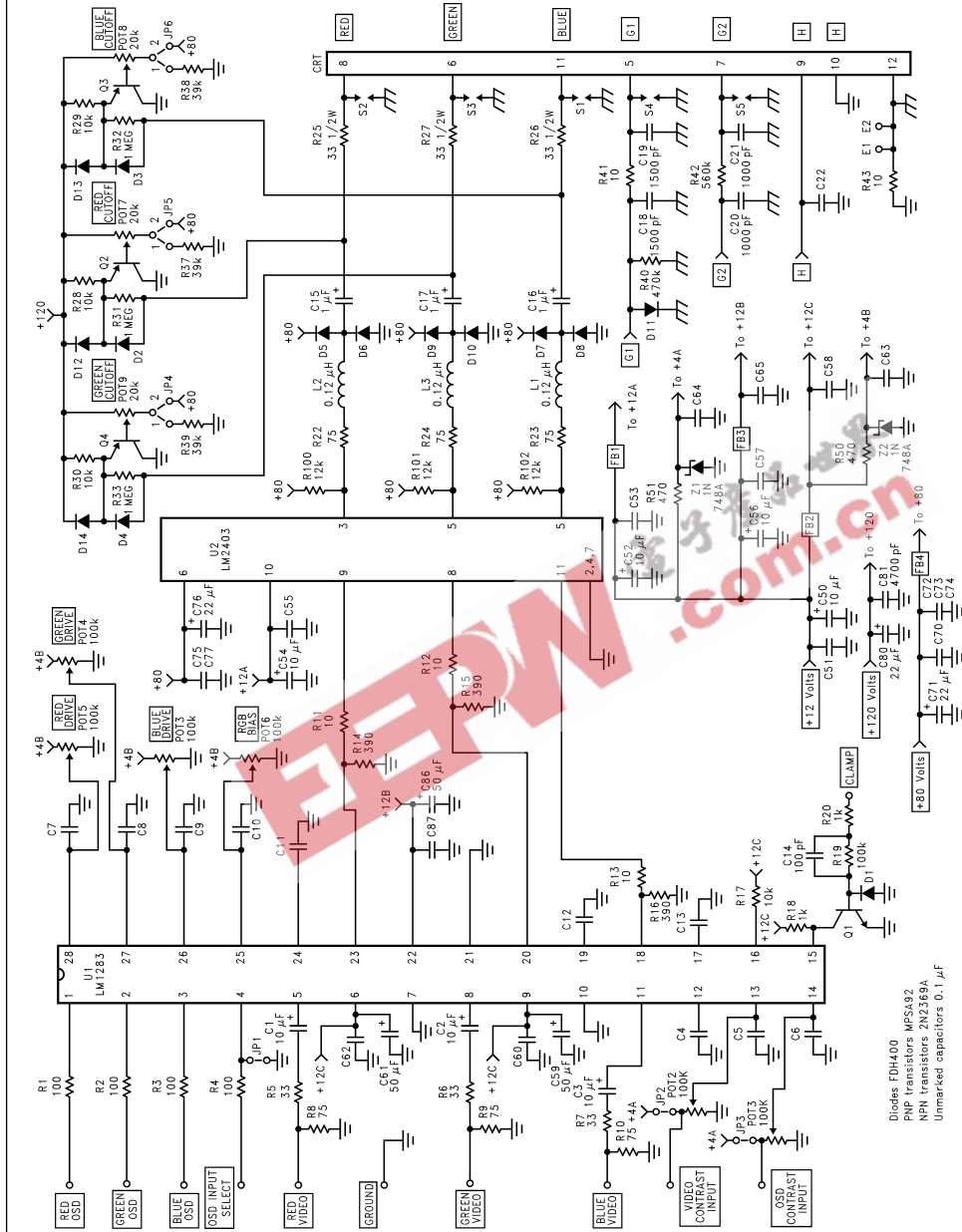

DS100082-12

FIGURE 11. LM1283/2403 Demonstration Board Schematic

- Diodes FDH400
- PNP transistors MPSA92
- NPN transistors 2N2369A
- Unmarked capacitors 0.1 μF

Application Hints (Continued)

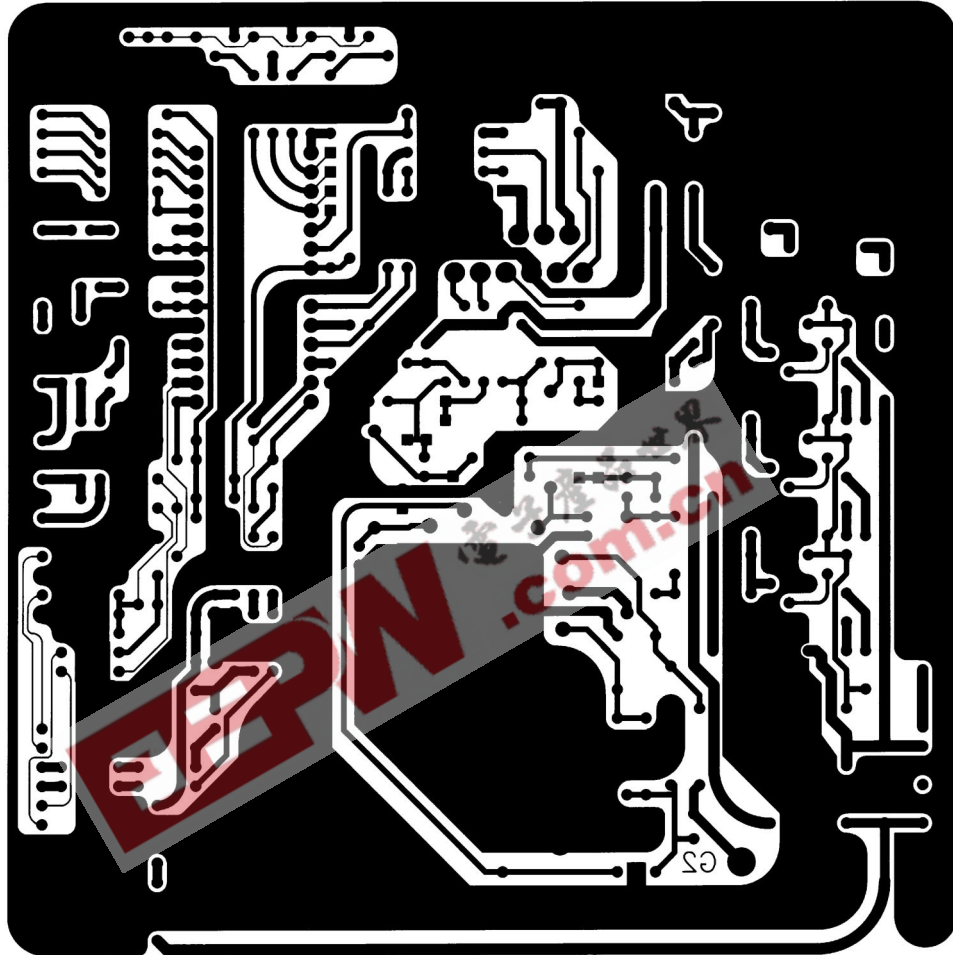
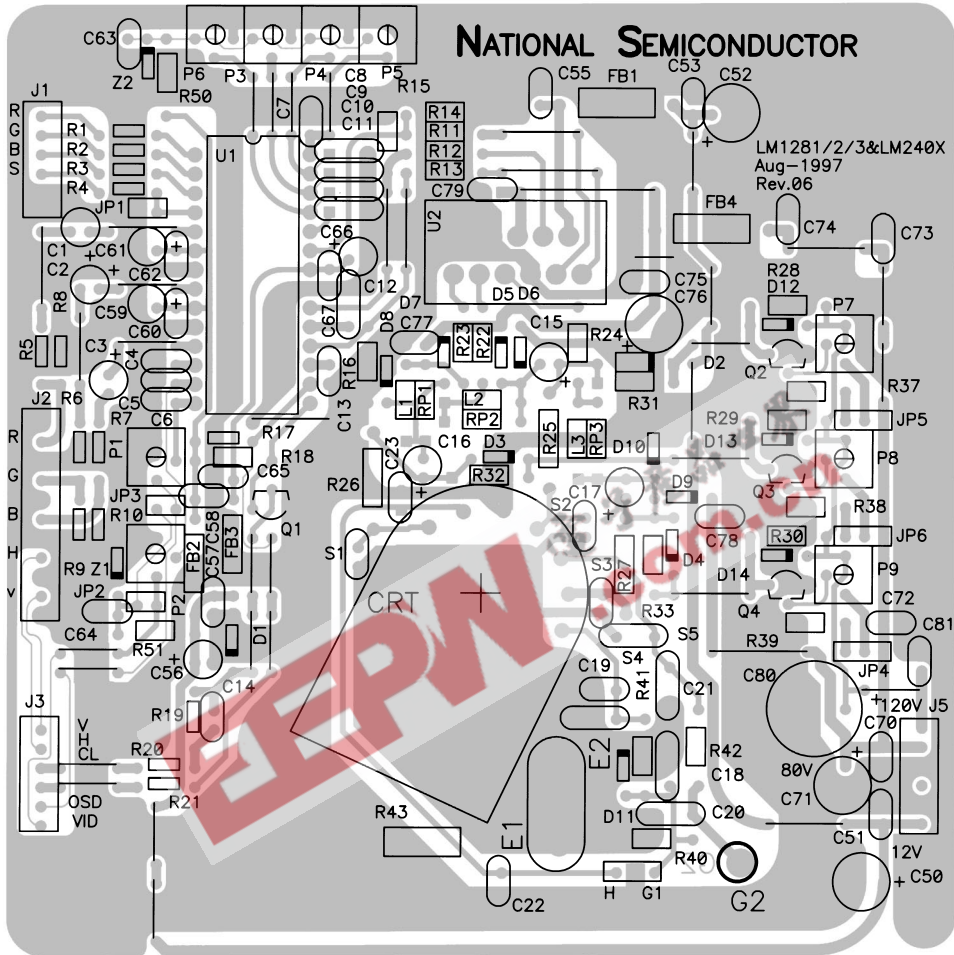

FIGURE 12. Trace Side of NSC LM1283/2403 Demonstration Board

DS100082-13

Application Hints (Continued)



DS100082-14

FIGURE 13. Silk Screen and Trace of the LM1283/2403 Demonstration Board

Application Hints (Continued)

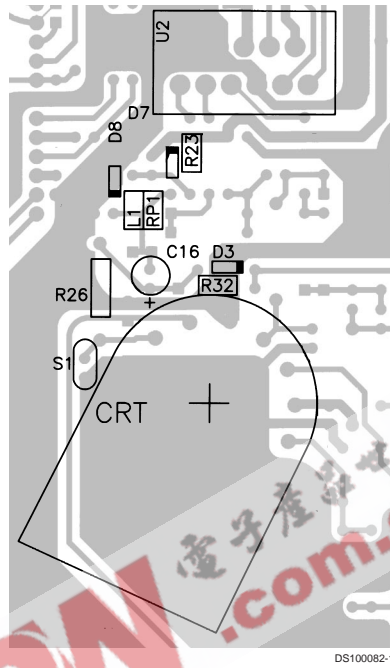
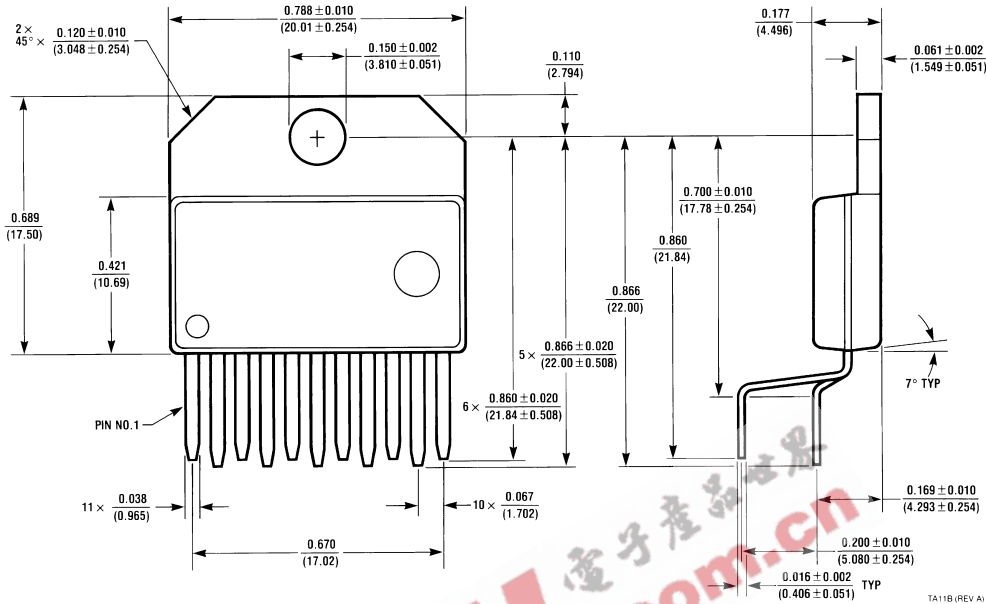

FIGURE 14. Blue Channel Component Placement and Trace Routing

Physical Dimensions inches (millimeters) unless otherwise noted



NS Package Number TA11B
Order Number LM2403T

LIFE SUPPORT POLICY

NATIONAL'S PRODUCTS ARE NOT AUTHORIZED FOR USE AS CRITICAL COMPONENTS IN LIFE SUPPORT DEVICES OR SYSTEMS WITHOUT THE EXPRESS WRITTEN APPROVAL OF THE PRESIDENT AND GENERAL COUNSEL OF NATIONAL SEMICONDUCTOR CORPORATION. As used herein:

1. Life support devices or systems are devices or systems which, (a) are intended for surgical implant into the body, or (b) support or sustain life, and whose failure to perform when properly used in accordance with instructions for use provided in the labeling, can be reasonably expected to result in a significant injury to the user.
2. A critical component is any component of a life support device or system whose failure to perform can be reasonably expected to cause the failure of the life support device or system, or to affect its safety or effectiveness.



National Semiconductor Corporation
Americas
Tel: 1-800-272-9959
Fax: 1-800-737-7018
Email: support@nsc.com

National Semiconductor Europe
Fax: +49 (0) 1 80-530 85 86
Email: europe.support@nsc.com
Deutsch Tel: +49 (0) 1 80-530 85 85
English Tel: +49 (0) 1 80-532 78 32
Français Tel: +49 (0) 1 80-532 93 58
Italiano Tel: +49 (0) 1 80-534 16 80

National Semiconductor Asia Pacific Customer Response Group
Tel: 65-2544466
Fax: 65-2504466
Email: sea.support@nsc.com

National Semiconductor Japan Ltd.
Tel: 81-3-5639-7560
Fax: 81-3-5639-7507

www.national.com