

## SYNCHRONOUS PRESETTABLE 4-BIT COUNTER

- HIGH SPEED  
 $f_{MAX} = 63 \text{ MHz (TYP.) AT } V_{CC} = 5 \text{ V}$
- LOW POWER DISSIPATION  
 $I_{CC} = 4 \mu\text{A (MAX.) AT } 25 \text{ }^\circ\text{C}$
- OUTPUT DRIVE CAPABILITY  
 10 LSTTL LOADS
- BALANCED PROPAGATION DELAYS  
 $t_{PLH} = t_{PHL}$
- HIGH NOISE IMMUNITY  
 $V_{NIH} = V_{NIL} = 28 \% V_{CC} \text{ (MIN.)}$
- WIDE OPERATING VOLTAGE RANGE  
 $V_{CC} \text{ (OPR)} = 2 \text{ V TO } 6 \text{ V}$
- PIN AND FUNCTION COMPATIBLE  
 WITH 54/74LS160 ~ 163

### DESCRIPTION

M54/74HC160 Decade, Asynchronous Clear  
 M54/74HC161 Binary, Asynchronous Clear  
 M54/74HC162 Decade, Synchronous Clear  
 M54/74HC163 Binary, Synchronous Clear

The M54/74HC160, 161, 162 and 163 are high speed CMOS SYNCHRONOUS PRESETTABLE COUNTERS fabricated with silicon gate C<sup>2</sup>MOS technology.

They have the same the high speed operation similar to equivalent LSTTL while maintaining the CMOS low power dissipation.

The M54/74HC160/162 are BCD Decade counters and the M54/74HC161/163 are 4 bit binary counters.

The CLOCK input is active on the rising edge. Both LOAD and CLEAR inputs are active Low.

Presetting of all four IC's is synchronous on the rising edge of the CLOCK.

The function on the M54/74HC162/163 is synchronous to CLOCK, while the M54/74HC160/161 counters are cleared asynchronously.

Two enable inputs (TE and PE) and CARRY output are provided to enable easy cascading of counters, which facilitates easy implementation of N-bit counters without using external gates.

All inputs are equipped with protection circuits against static discharge and transient excess voltage.

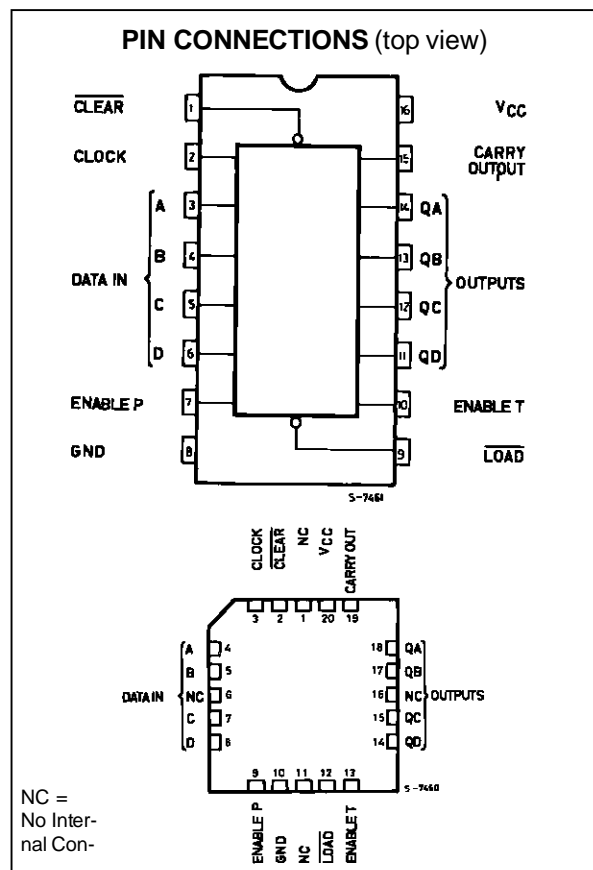
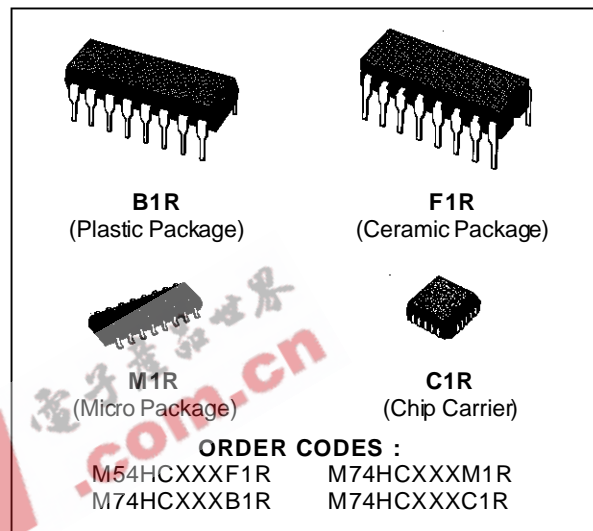

# M54/M74HC160/161/162/163

## INPUT AND OUTPUT EQUIVALENT CIRCUIT

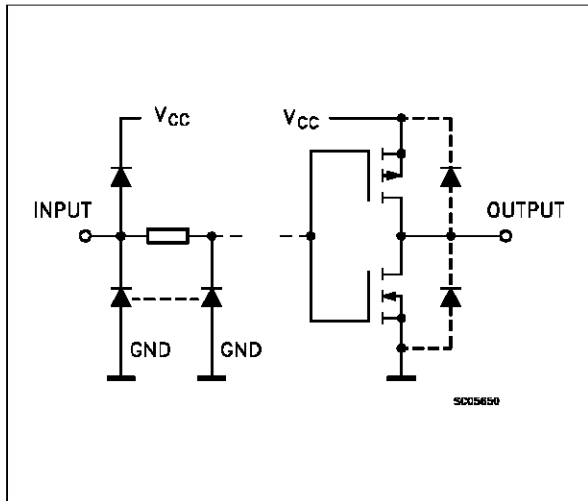

## PIN DESCRIPTION

| PIN No         | SYMBOL          | NAME AND FUNCTION                         |
|----------------|-----------------|---|
| 1              | CLEAR           | Asynchronous Master reset                 |
| 2              | CLOCK           | Clock Input (LOW to HIGH, Edge-triggered) |
| 3, 4, 5, 6     | A, B, C, D      | Data Inputs                               |
| 7              | ENABLE P        | Count Enable Input                        |
| 10             | ENABLET         | Count Enable Carry Input                  |
| 9              | LOAD            | Parallel Enable Input                     |
| 14, 13, 12, 11 | QA to QD        | Flip Flop Outputs                         |
| 15             | CARRY OUTPUT    | Terminal Count Output                     |
| 8              | GND             | Ground (0V)                               |
| 16             | V <sub>CC</sub> | Positive Supply Voltage                   |

## IEC LOGIC SYMBOL (HC160)

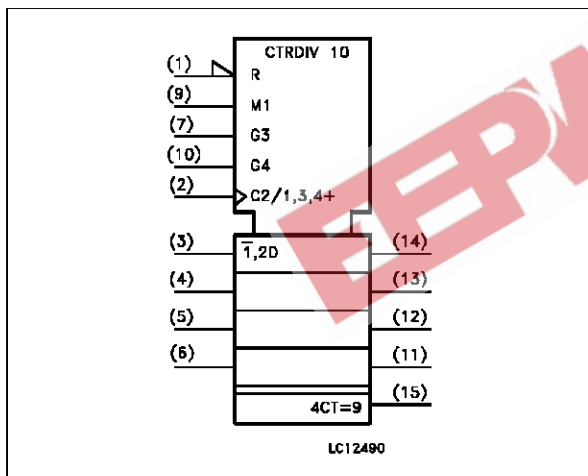

## IEC LOGIC SYMBOL (HC161)

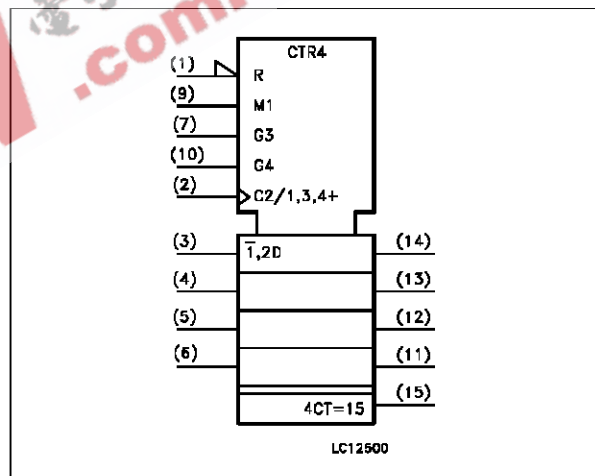

## IEC LOGIC SYMBOL (HC162)

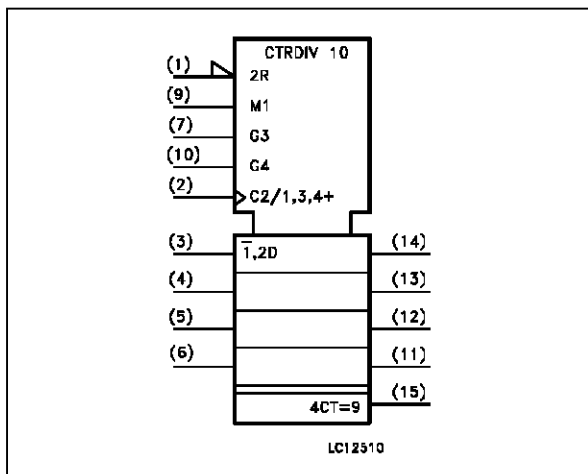

## IEC LOGIC SYMBOL (HC163)

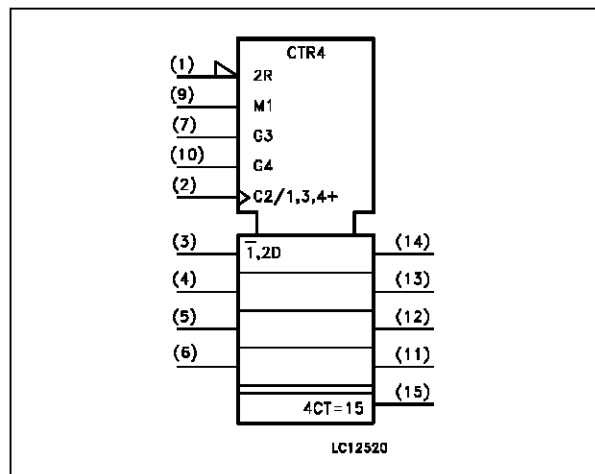

TRUTH TABLE

| M54/74HC160/161 |    |    |    |    | M54/74HC162/163 |    |    |    |    | OUTPUTS   |    |    |    | FUNCTION     |
|-----------------|----|----|----|----|-----------------|----|----|----|----|-----------|----|----|----|--------------|
| INPUTS          |    |    |    |    | INPUTS          |    |    |    |    | QA        | QB | QC | QD |              |
| CLR             | LD | PE | TE | CK | CLR             | LD | PE | TE | CK |           |    |    |    |              |
| L               | X  | X  | X  | X  | L               | X  | X  | X  | ┌  | L         | L  | L  | L  | RESET TO "0" |
| H               | L  | X  | X  | ┌  | H               | L  | X  | X  | ┌  | A         | B  | C  | D  | PRESET DATA  |
| H               | H  | X  | L  | ┌  | H               | H  | X  | L  | ┌  | NO CHANGE |    |    |    | NO COUNT     |
| H               | H  | L  | X  | ┌  | H               | H  | L  | X  | ┌  | NO CHANGE |    |    |    | NO COUNT     |
| H               | H  | H  | H  | ┌  | H               | H  | H  | H  | ┌  | COUNT UP  |    |    |    | COUNT        |
| H               | X  | X  | X  | └  | X               | X  | X  | X  | └  | NO CHANGE |    |    |    | NO COUNT     |

Note: X : Don't Care  
 A, B, C, D : Logi level of data inputs  
 Carry : CARRY = TE • QA • QB • QC • QD ..... (M54/74HC160/162)  
 : CARRY = TE • QA • QB • QC • QD ..... (M54/74HC161/163)

TIMING CHART (HC160/162 : decade counter)

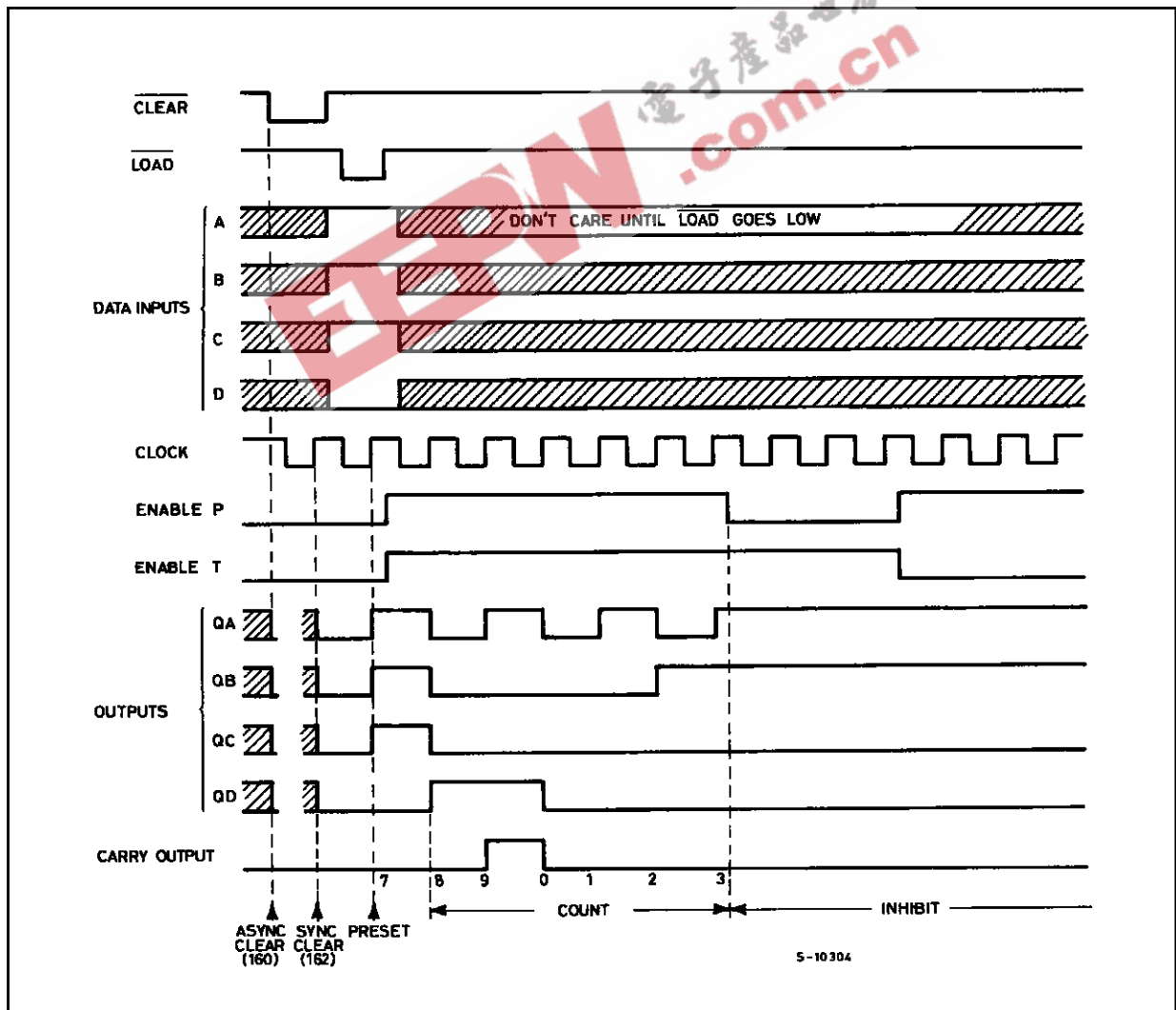

# M54/M74HC160/161/162/163

## TIMING CHART (HC161/163 : binary counter)

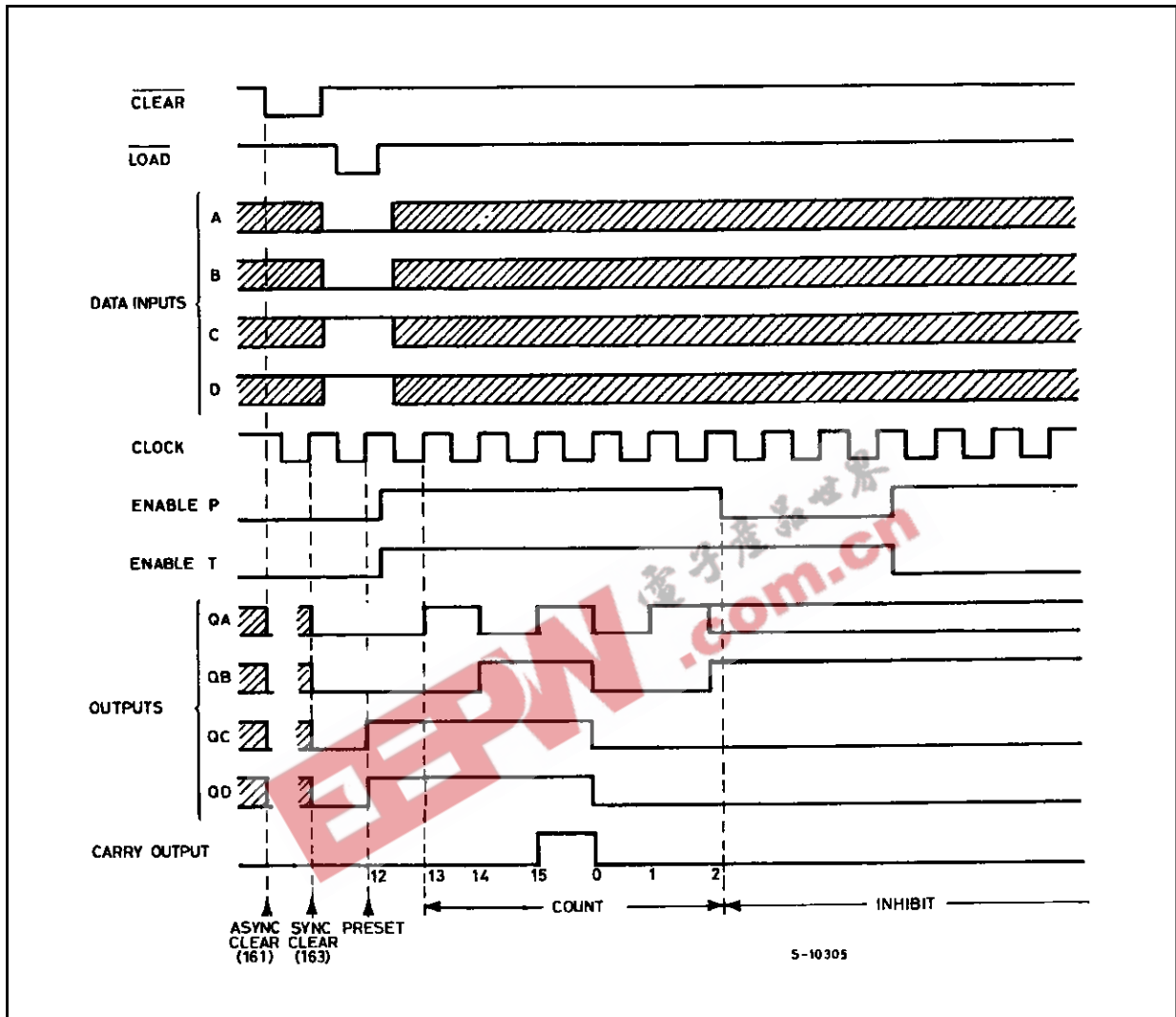

LOGIC DIAGRAM

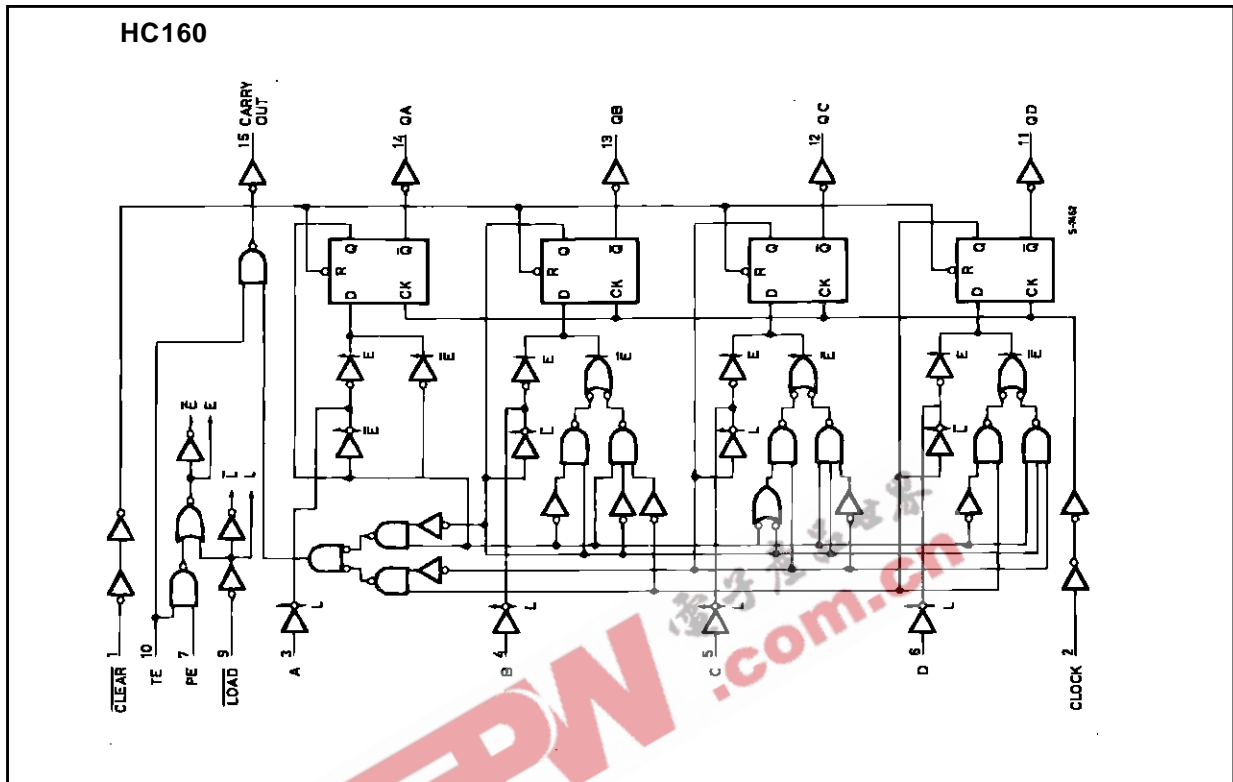

LOGIC DIAGRAM

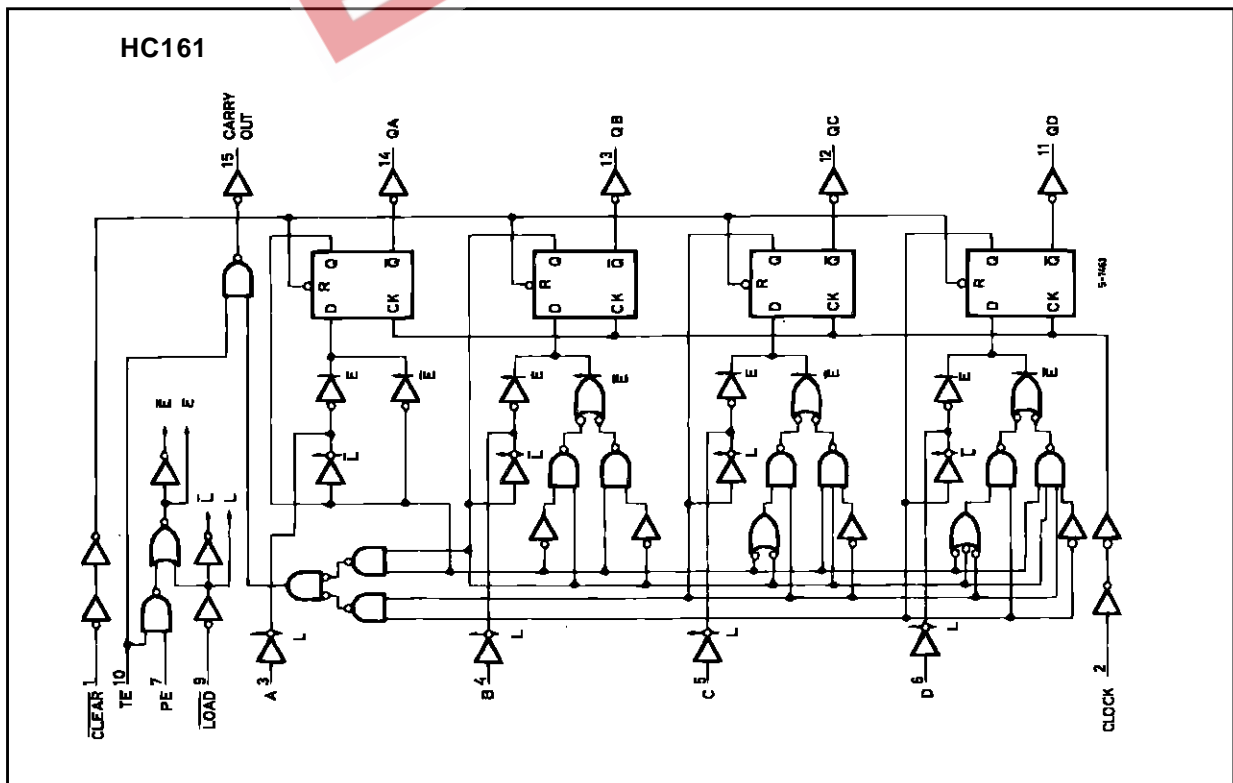

M54/M74HC160/161/162/163

LOGIC DIAGRAM

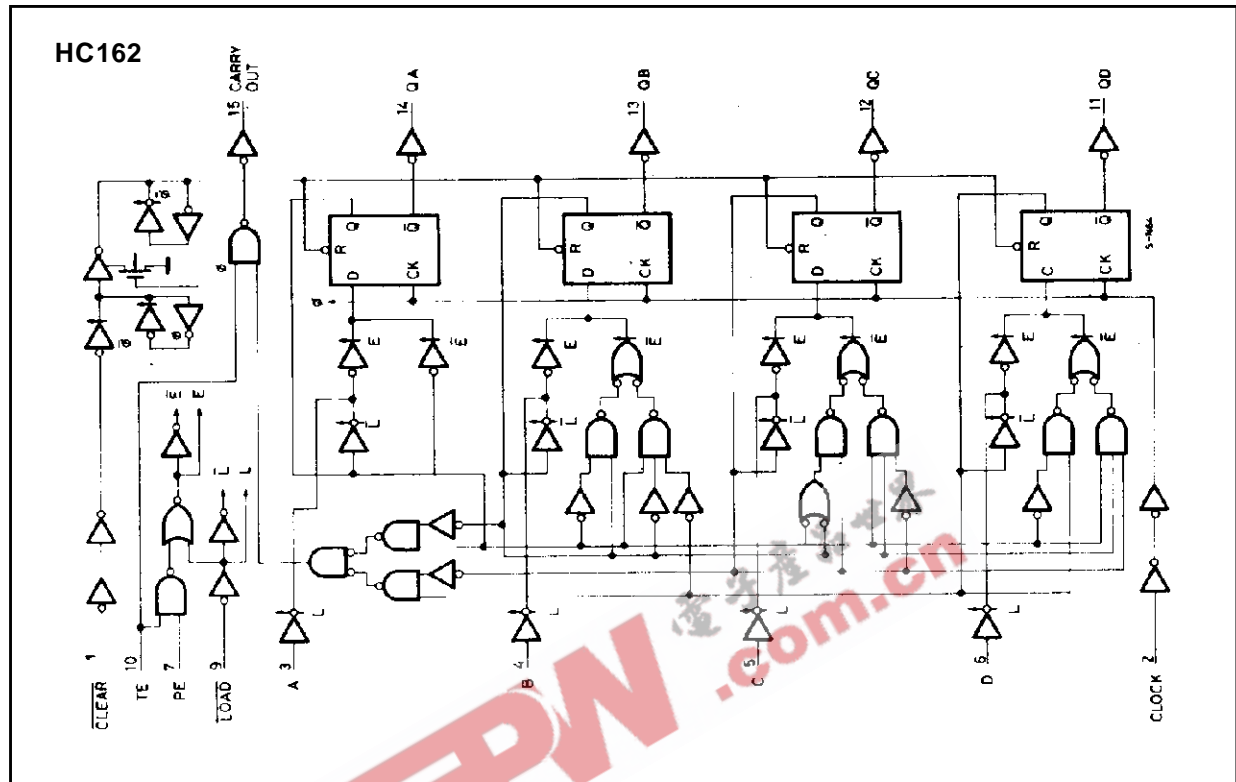

LOGIC DIAGRAM

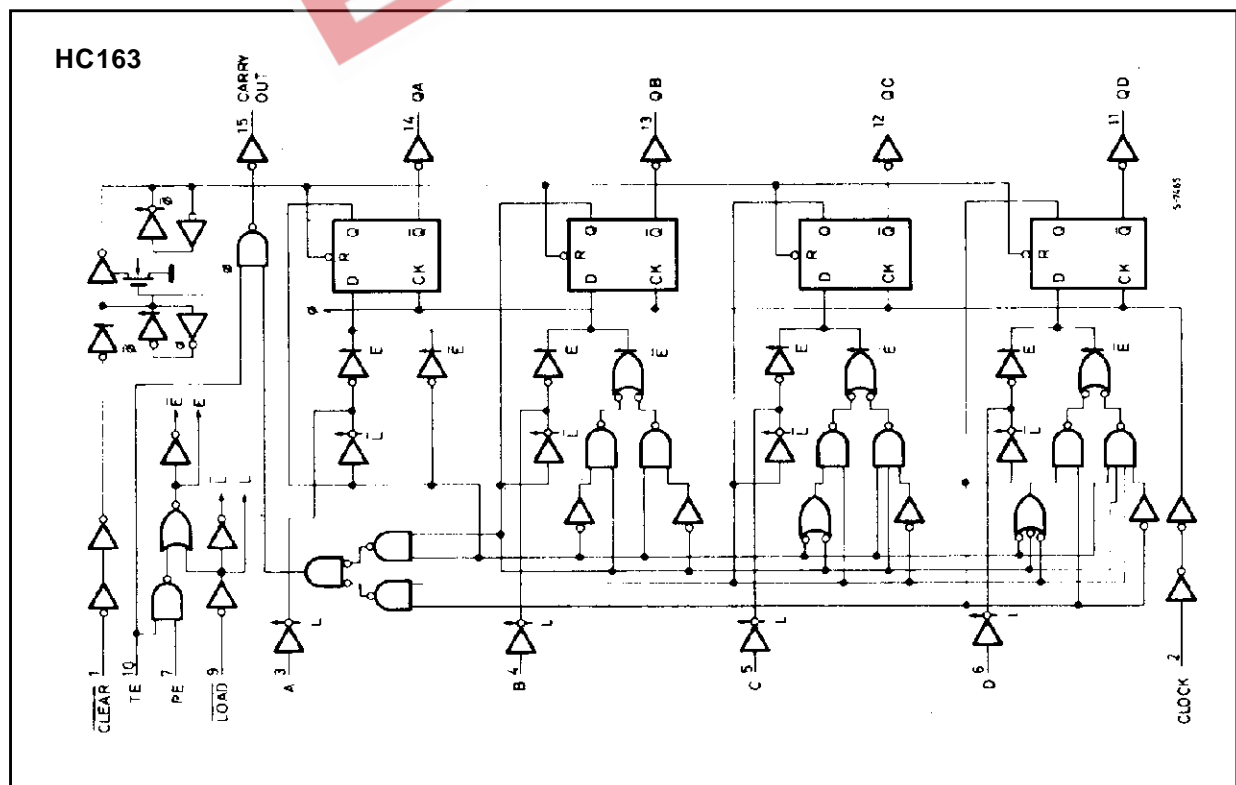

## ABSOLUTE MAXIMUM RATINGS

| Symbol                              | Parameter                                    | Value                         | Unit |
|-------------------------------------|--|-------------------------------|------|
| V <sub>CC</sub>                     | Supply Voltage                               | -0.5 to +7                    | V    |
| V <sub>I</sub>                      | DC Input Voltage                             | -0.5 to V <sub>CC</sub> + 0.5 | V    |
| V <sub>O</sub>                      | DC Output Voltage                            | -0.5 to V <sub>CC</sub> + 0.5 | V    |
| I <sub>IK</sub>                     | DC Input Diode Current                       | ± 20                          | mA   |
| I <sub>OK</sub>                     | DC Output Diode Current                      | ± 20                          | mA   |
| I <sub>O</sub>                      | DC Output Source Sink Current Per Output Pin | ± 25                          | mA   |
| I <sub>CC</sub> or I <sub>GND</sub> | DC V <sub>CC</sub> or Ground Current         | ± 50                          | mA   |
| P <sub>D</sub>                      | Power Dissipation                            | 500 (*)                       | mW   |
| T <sub>stg</sub>                    | Storage Temperature                          | -65 to +150                   | °C   |
| T <sub>L</sub>                      | Lead Temperature (10 sec)                    | 300                           | °C   |

Absolute Maximum Ratings are those values beyond which damage to the device may occur. Functional operation under these condition is not implied.

(\*) 500 mW: ≅ 65 °C derate to 300 mW by 10mW/°C: 65 °C to 85 °C

## RECOMMENDED OPERATING CONDITIONS

| Symbol                          | Parameter   | Value   | Unit                              |    |
|---------------------------------|---|---|-----------------------------------|----|
| V <sub>CC</sub>                 | Supply Voltage  | 2 to 6  | V                                 |    |
| V <sub>I</sub>                  | Input Voltage   | 0 to V <sub>CC</sub>  | V                                 |    |
| V <sub>O</sub>                  | Output Voltage  | 0 to V <sub>CC</sub>  | V                                 |    |
| T <sub>op</sub>                 | Operating Temperature: <b>M54HC Series</b><br><b>M74HC Series</b> | -55 to +125<br>-40 to +85   | °C<br>°C                          |    |
| t <sub>r</sub> , t <sub>f</sub> | Input Rise and Fall Time  | V <sub>CC</sub> = 2 V<br>V <sub>CC</sub> = 4.5 V<br>V <sub>CC</sub> = 6 V | 0 to 1000<br>0 to 500<br>0 to 400 | ns |

## M54/M74HC160/161/162/163

### DC SPECIFICATIONS

| Symbol          | Parameter                 | Test Conditions        |  | Value                                   |      |      |                      |      |                       | Unit |      |
|-----------------|---------------------------|------------------------|--|---|------|------|----------------------|------|-----------------------|------|------|
|                 |                           | V <sub>CC</sub><br>(V) |  | T <sub>A</sub> = 25 °C<br>54HC and 74HC |      |      | -40 to 85 °C<br>74HC |      | -55 to 125 °C<br>54HC |      |      |
|                 |                           |                        |  | Min.                                    | Typ. | Max. | Min.                 | Max. | Min.                  |      | Max. |
| V <sub>IH</sub> | High Level Input Voltage  | 2.0                    |  | 1.5                                     |      |      | 1.5                  |      | 1.5                   |      | V    |
|                 |                           | 4.5                    |  | 3.15                                    |      |      | 3.15                 |      | 3.15                  |      |      |
|                 |                           | 6.0                    |  | 4.2                                     |      |      | 4.2                  |      | 4.2                   |      |      |
| V <sub>IL</sub> | Low Level Input Voltage   | 2.0                    |  |   |      | 0.5  |                      | 0.5  |                       | 0.5  | V    |
|                 |                           | 4.5                    |  |   |      | 1.35 |                      | 1.35 |                       | 1.35 |      |
|                 |                           | 6.0                    |  |   |      | 1.8  |                      | 1.8  |                       | 1.8  |      |
| V <sub>OH</sub> | High Level Output Voltage | 2.0                    | V <sub>I</sub> =<br>V <sub>IH</sub><br>or<br>V <sub>IL</sub> | I <sub>O</sub> = -20 μA                 | 1.9  | 2.0  |                      | 1.9  |                       | 1.9  | V    |
|                 |                           | 4.5                    |  |   | 4.4  | 4.5  |                      | 4.4  |                       | 4.4  |      |
|                 |                           | 6.0                    |  |   | 5.9  | 6.0  |                      | 5.9  |                       | 5.9  |      |
|                 |                           | 4.5                    | I <sub>O</sub> = -4.0 mA                                     | 4.18                                    | 4.31 |      | 4.13                 |      | 4.10                  |      |      |
|                 |                           | 6.0                    |  | I <sub>O</sub> = -5.2 mA                | 5.68 | 5.8  |                      | 5.63 |                       | 5.60 |      |
| V <sub>OL</sub> | Low Level Output Voltage  | 2.0                    | V <sub>I</sub> =<br>V <sub>IH</sub><br>or<br>V <sub>IL</sub> | I <sub>O</sub> = 20 μA                  |      | 0.0  | 0.1                  |      | 0.1                   | 0.1  | V    |
|                 |                           | 4.5                    |  |   |      | 0.0  | 0.1                  |      | 0.1                   | 0.1  |      |
|                 |                           | 6.0                    |  |   |      | 0.0  | 0.1                  |      | 0.1                   | 0.1  |      |
|                 |                           | 4.5                    | I <sub>O</sub> = 4.0 mA                                      | 0.17                                    | 0.26 |      | 0.33                 |      | 0.40                  |      |      |
|                 |                           | 6.0                    |  | I <sub>O</sub> = 5.2 mA                 | 0.18 | 0.26 |                      | 0.33 |                       | 0.40 |      |
| I <sub>I</sub>  | Input Leakage Current     | 6.0                    | V <sub>I</sub> = V <sub>CC</sub> or GND                      |   |      | ±0.1 |                      | ±1   |                       | ±1   | μA   |
| I <sub>CC</sub> | Quiescent Supply Current  | 6.0                    | V <sub>I</sub> = V <sub>CC</sub> or GND                      |   |      | 4    |                      | 40   |                       | 80   | μA   |



M54/M74HC160/161/162/163

AC ELECTRICAL CHARACTERISTICS (C<sub>L</sub> = 50 pF, Input t<sub>r</sub> = t<sub>f</sub> = 6 ns)

| Symbol                                 | Parameter                            | Test Conditions        |                    | Value                                   |      |      |                      |      |                       | Unit |      |
|--|--------------------------------------|------------------------|--------------------|---|------|------|----------------------|------|-----------------------|------|------|
|  |                                      | V <sub>CC</sub><br>(V) |                    | T <sub>A</sub> = 25 °C<br>54HC and 74HC |      |      | -40 to 85 °C<br>74HC |      | -55 to 125 °C<br>54HC |      |      |
|  |                                      |                        |                    | Min.                                    | Typ. | Max. | Min.                 | Max. | Min.                  |      | Max. |
| t <sub>TLH</sub><br>t <sub>THL</sub>   | Output Transition Time               | 2.0                    |                    |   | 25   | 75   |                      | 95   |                       | 110  | ns   |
|  |                                      | 4.5                    |                    |   | 7    | 15   |                      | 19   |                       | 22   |      |
|  |                                      | 6.0                    |                    |   | 6    | 13   |                      | 16   |                       | 19   |      |
| t <sub>PLH</sub><br>t <sub>PHL</sub>   | Propagation Delay Time (CLOCK - Q)   | 2.0                    |                    |   | 48   | 125  |                      | 155  |                       | 190  | ns   |
|  |                                      | 4.5                    |                    |   | 16   | 25   |                      | 31   |                       | 38   |      |
|  |                                      | 6.0                    |                    |   | 14   | 21   |                      | 26   |                       | 32   |      |
| t <sub>PLH</sub><br>t <sub>PHL</sub>   | Propagation Delay Time (CLOCK-CARRY) | 2.0                    | COUNT MODE         |   | 57   | 150  |                      | 190  |                       | 225  | ns   |
|  |                                      | 4.5                    |                    |   | 19   | 30   |                      | 38   |                       | 45   |      |
|  |                                      | 6.0                    |                    |   | 16   | 26   |                      | 32   |                       | 38   |      |
| t <sub>PLH</sub>                       | Propagation Delay Time (CLOCK-CARRY) | 2.0                    | PRESET MODE        |   | 66   | 175  |                      | 220  |                       | 265  | ns   |
|  |                                      | 4.5                    |                    |   | 22   | 35   |                      | 44   |                       | 53   |      |
|  |                                      | 6.0                    |                    |   | 19   | 30   |                      | 37   |                       | 45   |      |
| t <sub>PHL</sub>                       | Propagation Delay Time (CLOCK-CARRY) | 2.0                    | PRESET MODE        |   | 72   | 200  |                      | 250  |                       | 300  | ns   |
|  |                                      | 4.5                    |                    |   | 24   | 40   |                      | 50   |                       | 60   |      |
|  |                                      | 6.0                    |                    |   | 20   | 34   |                      | 43   |                       | 51   |      |
| t <sub>PLH</sub><br>t <sub>PHL</sub>   | Propagation Delay Time (ENT-CARRY)   | 2.0                    |                    |   | 39   | 100  |                      | 125  |                       | 150  | ns   |
|  |                                      | 4.5                    |                    |   | 13   | 20   |                      | 25   |                       | 30   |      |
|  |                                      | 6.0                    |                    |   | 11   | 17   |                      | 21   |                       | 26   |      |
| t <sub>PLH</sub>                       | Propagation Delay Time (CLEAR - Q)   | 2.0                    | for HC160/161 only |   | 60   | 150  |                      | 190  |                       | 225  | ns   |
|  |                                      | 4.5                    |                    |   | 20   | 30   |                      | 38   |                       | 45   |      |
|  |                                      | 6.0                    |                    |   | 17   | 26   |                      | 32   |                       | 38   |      |
| t <sub>PHL</sub>                       | Propagation Delay Time (CLEAR-CARRY) | 2.0                    | for HC160/161 only |   | 72   | 200  |                      | 250  |                       | 300  | ns   |
|  |                                      | 4.5                    |                    |   | 24   | 40   |                      | 50   |                       | 60   |      |
|  |                                      | 6.0                    |                    |   | 20   | 34   |                      | 43   |                       | 51   |      |
| f <sub>MAX</sub>                       | Maximum Clock Frequency              | 2.0                    |                    | 6.2                                     | 18   |      | 5                    |      | 4.2                   | MHz  |      |
|  |                                      | 4.5                    |                    | 31                                      | 53   |      | 25                   |      | 21                    |      |      |
|  |                                      | 6.0                    |                    | 37                                      | 62   |      | 30                   |      | 25                    |      |      |
| t <sub>W(H)</sub><br>t <sub>W(L)</sub> | Minimum Pulse Width (CLOCK)          | 2.0                    |                    |   | 18   | 75   |                      | 95   |                       | 110  | ns   |
|  |                                      | 4.5                    |                    |   | 6    | 15   |                      | 19   |                       | 22   |      |
|  |                                      | 6.0                    |                    |   | 6    | 13   |                      | 16   |                       | 19   |      |
| t <sub>W(L)</sub>                      | Minimum Pulse Width (CLEAR)          | 2.0                    | for HC160/161 only |   | 24   | 75   |                      | 95   |                       | 110  | ns   |
|  |                                      | 4.5                    |                    |   | 7    | 15   |                      | 19   |                       | 22   |      |
|  |                                      | 6.0                    |                    |   | 6    | 13   |                      | 16   |                       | 19   |      |
| t <sub>s</sub>                         | Minimum Set-up Time (LOAD, PE, TE)   | 2.0                    |                    |   | 40   | 100  |                      | 125  |                       | 150  | ns   |
|  |                                      | 4.5                    |                    |   | 10   | 20   |                      | 25   |                       | 30   |      |
|  |                                      | 6.0                    |                    |   | 8    | 17   |                      | 21   |                       | 26   |      |
| t <sub>s</sub>                         | Minimum Set-up Time (A, B, C, D)     | 2.0                    |                    |   | 20   | 75   |                      | 95   |                       | 110  | ns   |
|  |                                      | 4.5                    |                    |   | 5    | 15   |                      | 19   |                       | 22   |      |
|  |                                      | 6.0                    |                    |   | 3    | 13   |                      | 16   |                       | 19   |      |
| t <sub>s</sub>                         | Minimum Set-up Time (CLEAR)          | 2.0                    | for HC162/163 only |   | 20   | 75   |                      | 95   |                       | 110  | ns   |
|  |                                      | 4.5                    |                    |   | 5    | 15   |                      | 19   |                       | 22   |      |
|  |                                      | 6.0                    |                    |   | 3    | 13   |                      | 16   |                       | 19   |      |

# M54/M74HC160/161/162/163

## AC ELECTRICAL CHARACTERISTICS (C<sub>L</sub> = 50 pF, Input t<sub>r</sub> = t<sub>f</sub> = 6 ns)

| Symbol              | Parameter                     | Test Conditions     |  | Value                                   |      |      |                      |      |                       | Unit |      |
|---------------------|-------------------------------|---------------------|--|---|------|------|----------------------|------|-----------------------|------|------|
|                     |                               | V <sub>CC</sub> (V) |  | T <sub>A</sub> = 25 °C<br>54HC and 74HC |      |      | -40 to 85 °C<br>74HC |      | -55 to 125 °C<br>54HC |      |      |
|                     |                               |                     |  | Min.                                    | Typ. | Max. | Min.                 | Max. | Min.                  |      | Max. |
| t <sub>h</sub>      | Minimum Hold Time (A, B - CK) | 2.0                 |  |   |      | 0    |                      | 0    |                       | 0    | ns   |
|                     |                               | 4.5                 |  |   |      | 0    |                      | 0    |                       | 0    |      |
|                     |                               | 6.0                 |  |   |      | 0    |                      | 0    |                       | 0    |      |
| t <sub>REM</sub>    | Minimum Removal Time          | 2.0                 |  | 18                                      | 50   |      | 65                   |      | 75                    | ns   |      |
|                     |                               | 4.5                 |  | 4                                       | 10   |      | 13                   |      | 15                    |      |      |
|                     |                               | 6.0                 |  | 3                                       | 9    |      | 11                   |      | 13                    |      |      |
| C <sub>IN</sub>     | Input Capacitance             |                     |  | 5                                       | 10   |      | 10                   |      | 10                    | pF   |      |
| C <sub>PD</sub> (*) | Power Dissipation Capacitance |                     |  | 50                                      |      |      |                      |      |                       | pF   |      |

(\*) C<sub>PD</sub> is defined as the value of the IC's internal equivalent capacitance which is calculated from the operating current consumption without load. (Refer to Test Circuit). Average operating current can be obtained by the following equation.  $I_{CC(OPR)} = C_{PD} \cdot V_{CC} \cdot f_{IN} + I_{CC}$

## SWITCHING CHARACTERISTICS TEST WAVEFORM

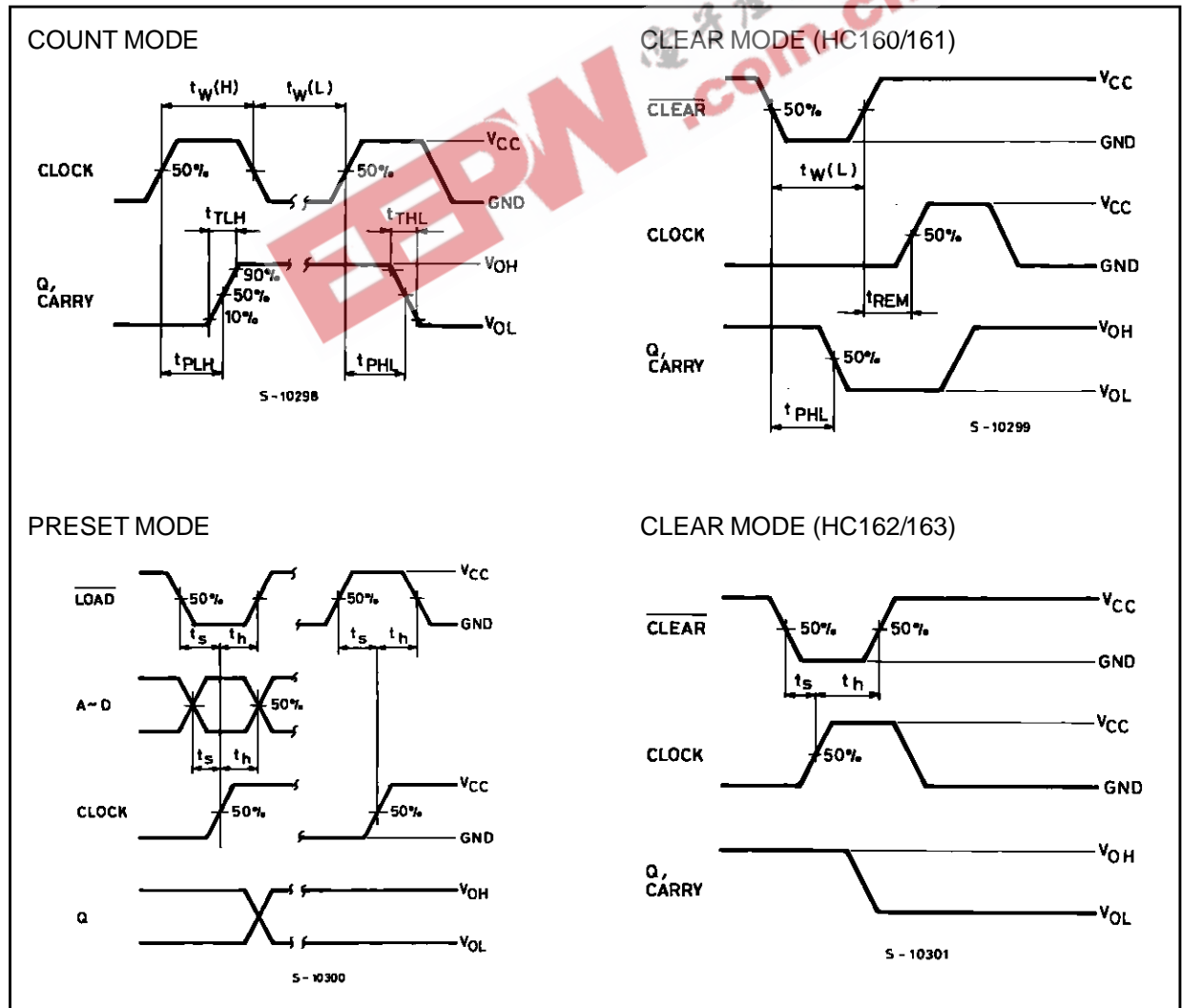

SWITCHING CHARACTERISTICS TEST WAVEFORM (continued)

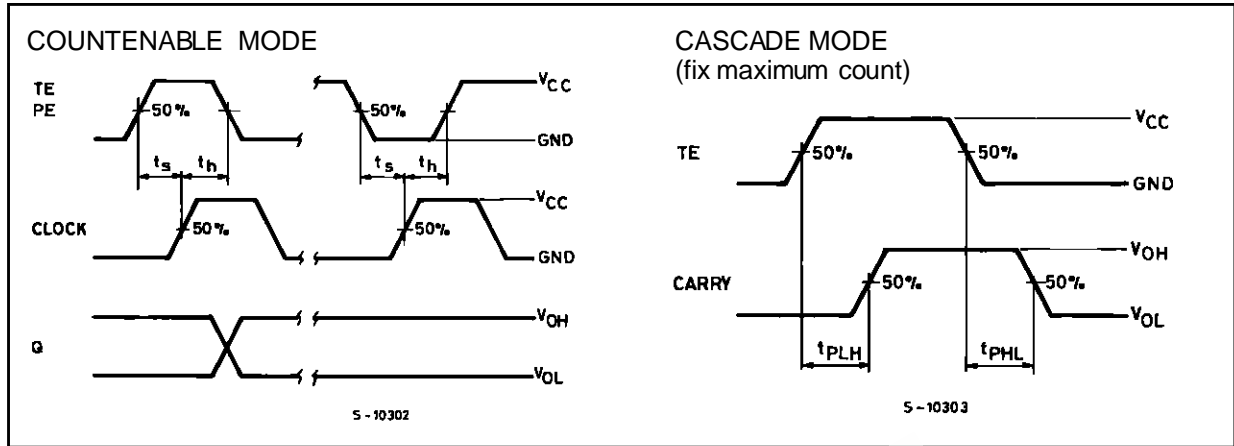

TEST CIRCUIT  $I_{CC}$  (Opr.)

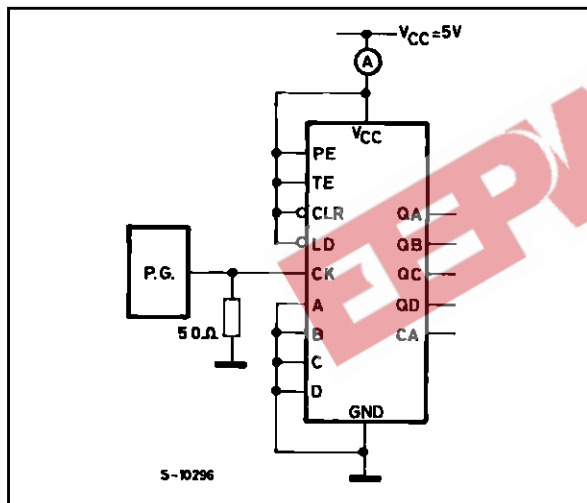

TOTAL OPERATING CURRENT WHEN USING A CAPACITIVE LOAD

When the outputs drive a capacitive load, the total current can be calculated as follows :

For M74HC160/162 :

$$\Delta I_{CC} = f_{CK} \cdot V_{CC} \cdot \left( \frac{C_a}{2} + \frac{C_b}{5} + \frac{C_c}{10} + \frac{C_d}{10} + \frac{C_{ca}}{10} \right)$$

For M74HC161/163 :

$$\Delta I_{CC} = f_{CK} \cdot V_{CC} \cdot \left( \frac{C_a}{2} + \frac{C_b}{4} + \frac{C_c}{8} + \frac{C_d}{16} + \frac{C_{ca}}{16} \right)$$

$C_a$  to  $C_{ca}$  are the capacitors loading the outputs.

TYPICAL APPLICATION

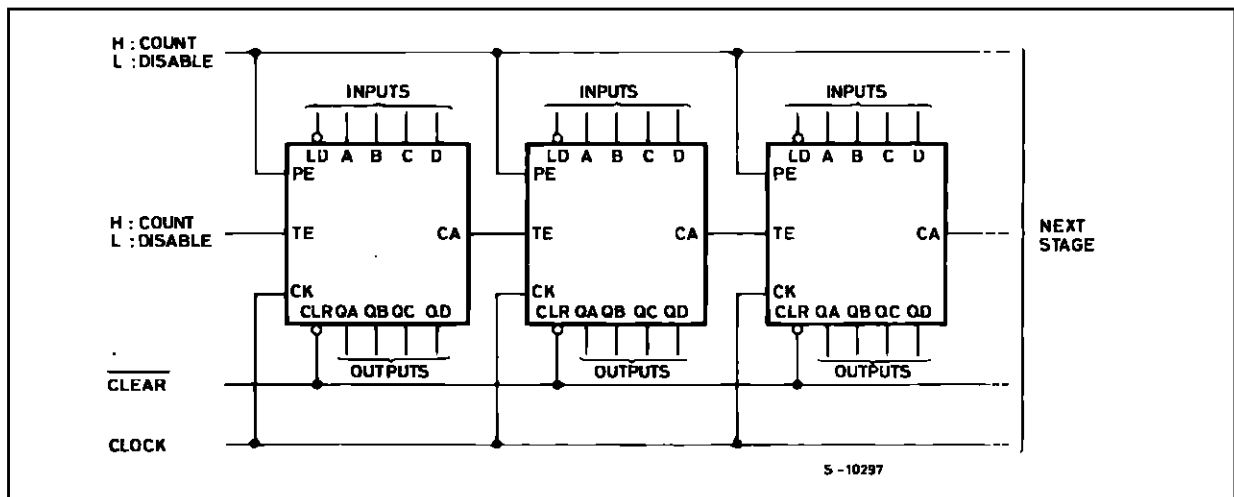

M54/M74HC160/161/162/163

Plastic DIP16 (0.25) MECHANICAL DATA

| DIM. | mm   |       |      | inch  |       |       |
|------|------|-------|------|-------|-------|-------|
|      | MIN. | TYP.  | MAX. | MIN.  | TYP.  | MAX.  |
| a1   | 0.51 |       |      | 0.020 |       |       |
| B    | 0.77 |       | 1.65 | 0.030 |       | 0.065 |
| b    |      | 0.5   |      |       | 0.020 |       |
| b1   |      | 0.25  |      |       | 0.010 |       |
| D    |      |       | 20   |       |       | 0.787 |
| E    |      | 8.5   |      |       | 0.335 |       |
| e    |      | 2.54  |      |       | 0.100 |       |
| e3   |      | 17.78 |      |       | 0.700 |       |
| F    |      |       | 7.1  |       |       | 0.280 |
| I    |      |       | 5.1  |       |       | 0.201 |
| L    |      | 3.3   |      |       | 0.130 |       |
| Z    |      |       | 1.27 |       |       | 0.050 |

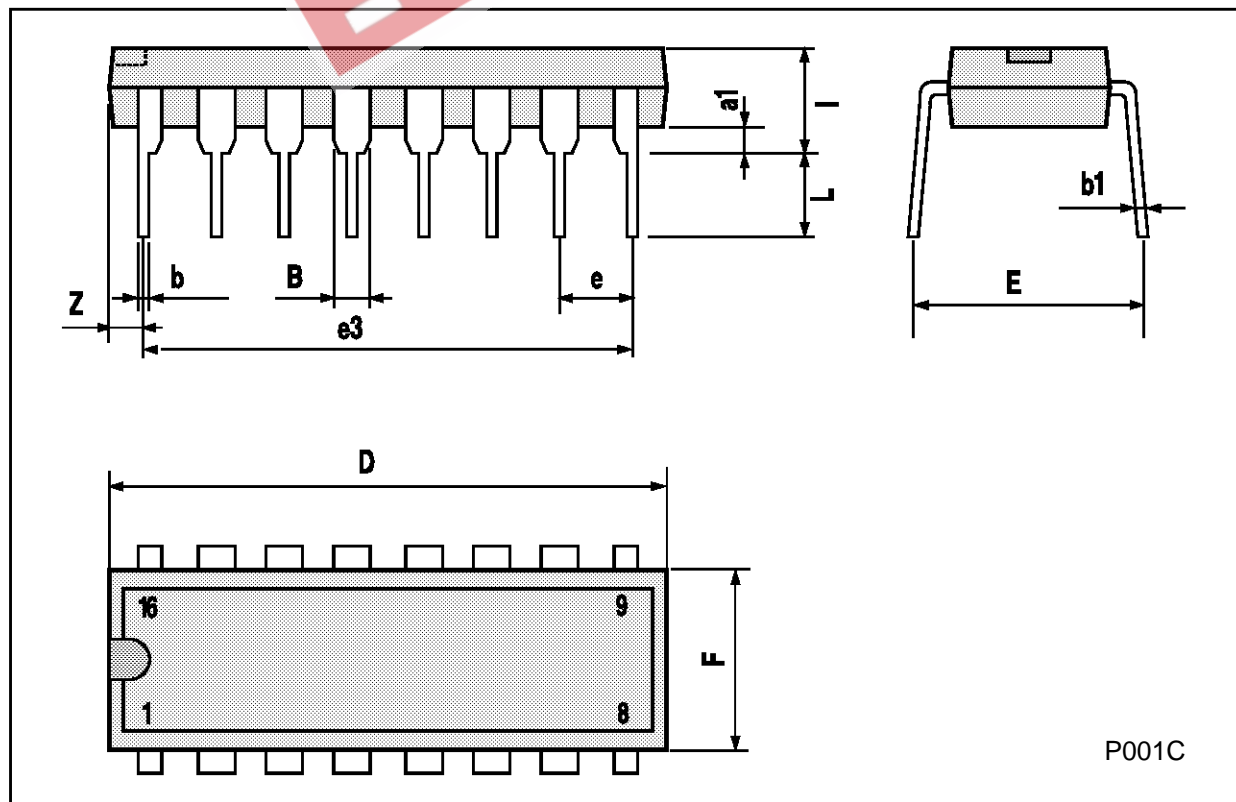

## Ceramic DIP16/1 MECHANICAL DATA

| DIM. | mm   |       |      | inch  |       |       |
|------|------|-------|------|-------|-------|-------|
|      | MIN. | TYP.  | MAX. | MIN.  | TYP.  | MAX.  |
| A    |      |       | 20   |       |       | 0.787 |
| B    |      |       | 7    |       |       | 0.276 |
| D    |      | 3.3   |      |       | 0.130 |       |
| E    | 0.38 |       |      | 0.015 |       |       |
| e3   |      | 17.78 |      |       | 0.700 |       |
| F    | 2.29 |       | 2.79 | 0.090 |       | 0.110 |
| G    | 0.4  |       | 0.55 | 0.016 |       | 0.022 |
| H    | 1.17 |       | 1.52 | 0.046 |       | 0.060 |
| L    | 0.22 |       | 0.31 | 0.009 |       | 0.012 |
| M    | 0.51 |       | 1.27 | 0.020 |       | 0.050 |
| N    |      |       | 10.3 |       |       | 0.406 |
| P    | 7.8  |       | 8.05 | 0.307 |       | 0.317 |
| Q    |      |       | 5.08 |       |       | 0.200 |

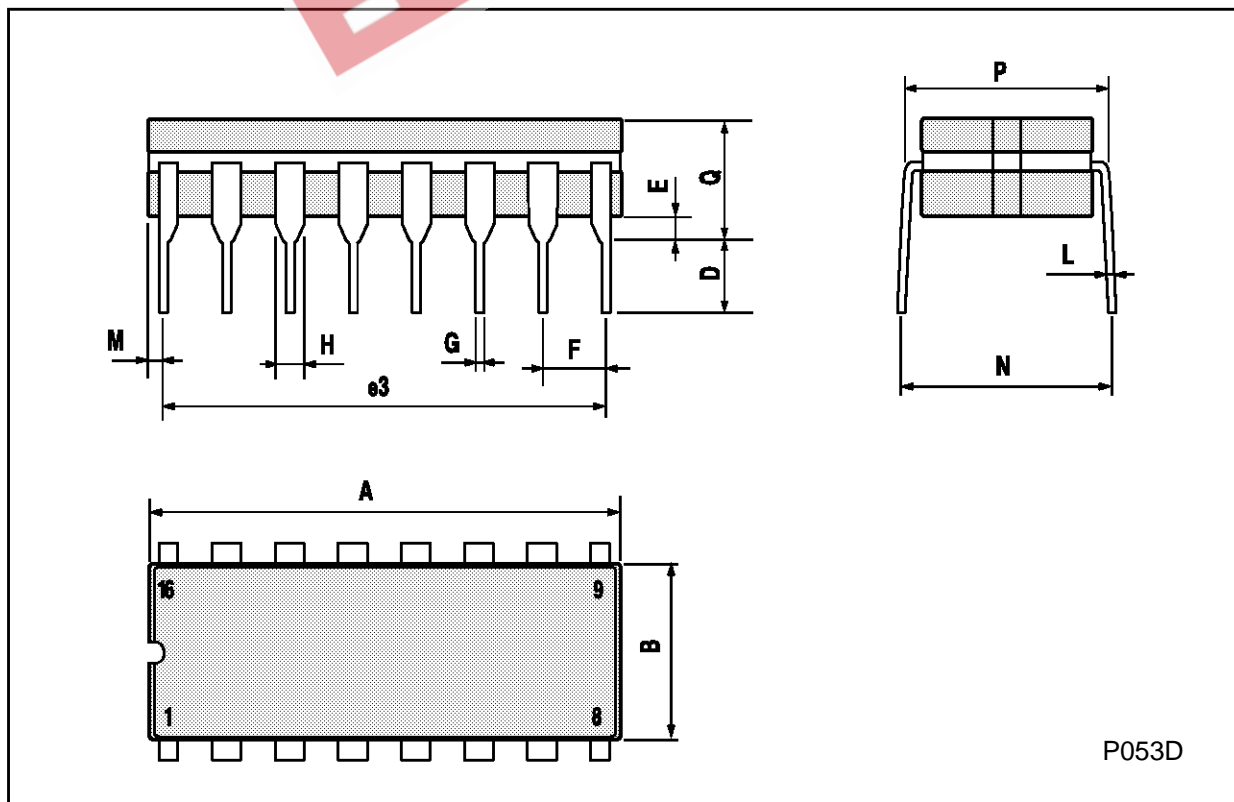

**SO16 (Narrow) MECHANICAL DATA**

| DIM. | mm         |      |      | inch  |       |       |
|------|------------|------|------|-------|-------|-------|
|      | MIN.       | TYP. | MAX. | MIN.  | TYP.  | MAX.  |
| A    |            |      | 1.75 |       |       | 0.068 |
| a1   | 0.1        |      | 0.2  | 0.004 |       | 0.007 |
| a2   |            |      | 1.65 |       |       | 0.064 |
| b    | 0.35       |      | 0.46 | 0.013 |       | 0.018 |
| b1   | 0.19       |      | 0.25 | 0.007 |       | 0.010 |
| C    |            | 0.5  |      |       | 0.019 |       |
| c1   | 45° (typ.) |      |      |       |       |       |
| D    | 9.8        |      | 10   | 0.385 |       | 0.393 |
| E    | 5.8        |      | 6.2  | 0.228 |       | 0.244 |
| e    |            | 1.27 |      |       | 0.050 |       |
| e3   |            | 8.89 |      |       | 0.350 |       |
| F    | 3.8        |      | 4.0  | 0.149 |       | 0.157 |
| G    | 4.6        |      | 5.3  | 0.181 |       | 0.208 |
| L    | 0.5        |      | 1.27 | 0.019 |       | 0.050 |
| M    |            |      | 0.62 |       |       | 0.024 |
| S    | 8° (max.)  |      |      |       |       |       |

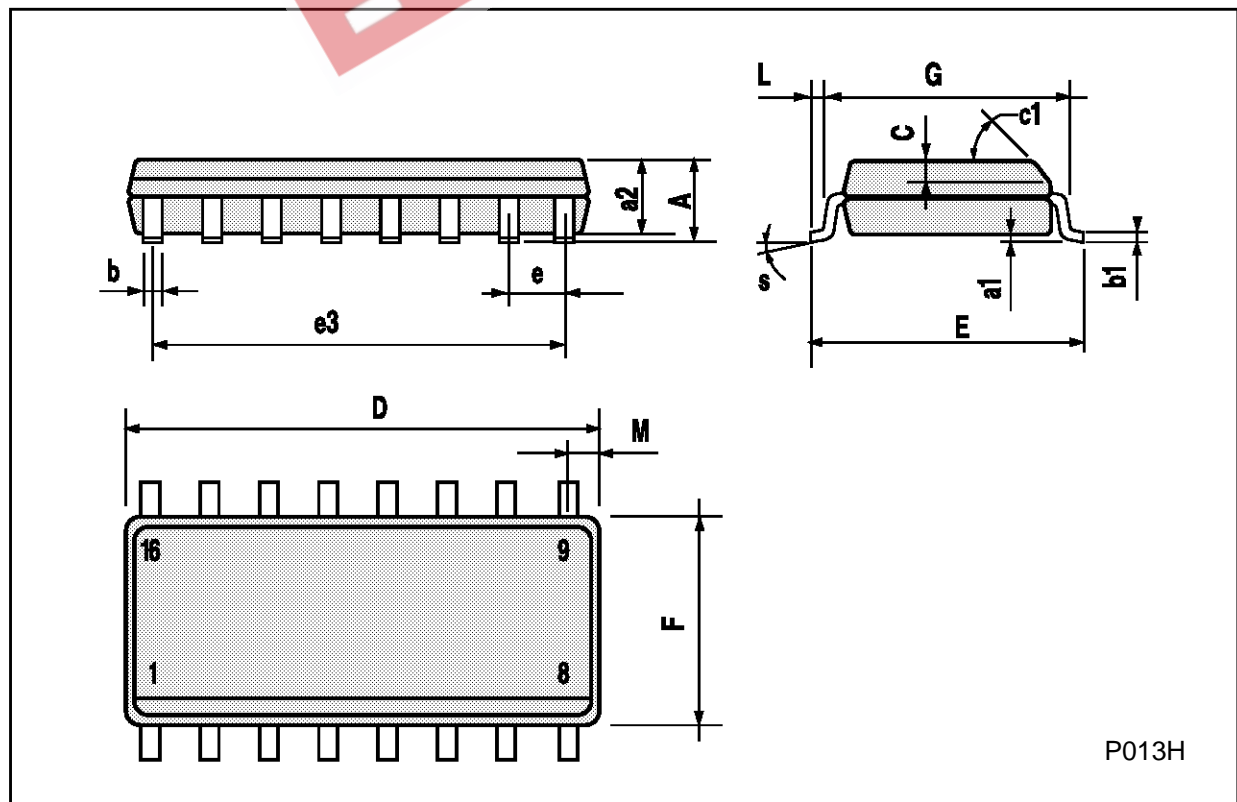

## PLCC20 MECHANICAL DATA

| DIM. | mm   |      |       | inch  |       |       |
|------|------|------|-------|-------|-------|-------|
|      | MIN. | TYP. | MAX.  | MIN.  | TYP.  | MAX.  |
| A    | 9.78 |      | 10.03 | 0.385 |       | 0.395 |
| B    | 8.89 |      | 9.04  | 0.350 |       | 0.356 |
| D    | 4.2  |      | 4.57  | 0.165 |       | 0.180 |
| d1   |      | 2.54 |       |       | 0.100 |       |
| d2   |      | 0.56 |       |       | 0.022 |       |
| E    | 7.37 |      | 8.38  | 0.290 |       | 0.330 |
| e    |      | 1.27 |       |       | 0.050 |       |
| e3   |      | 5.08 |       |       | 0.200 |       |
| F    |      | 0.38 |       |       | 0.015 |       |
| G    |      |      | 0.101 |       |       | 0.004 |
| M    |      | 1.27 |       |       | 0.050 |       |
| M1   |      | 1.14 |       |       | 0.045 |       |

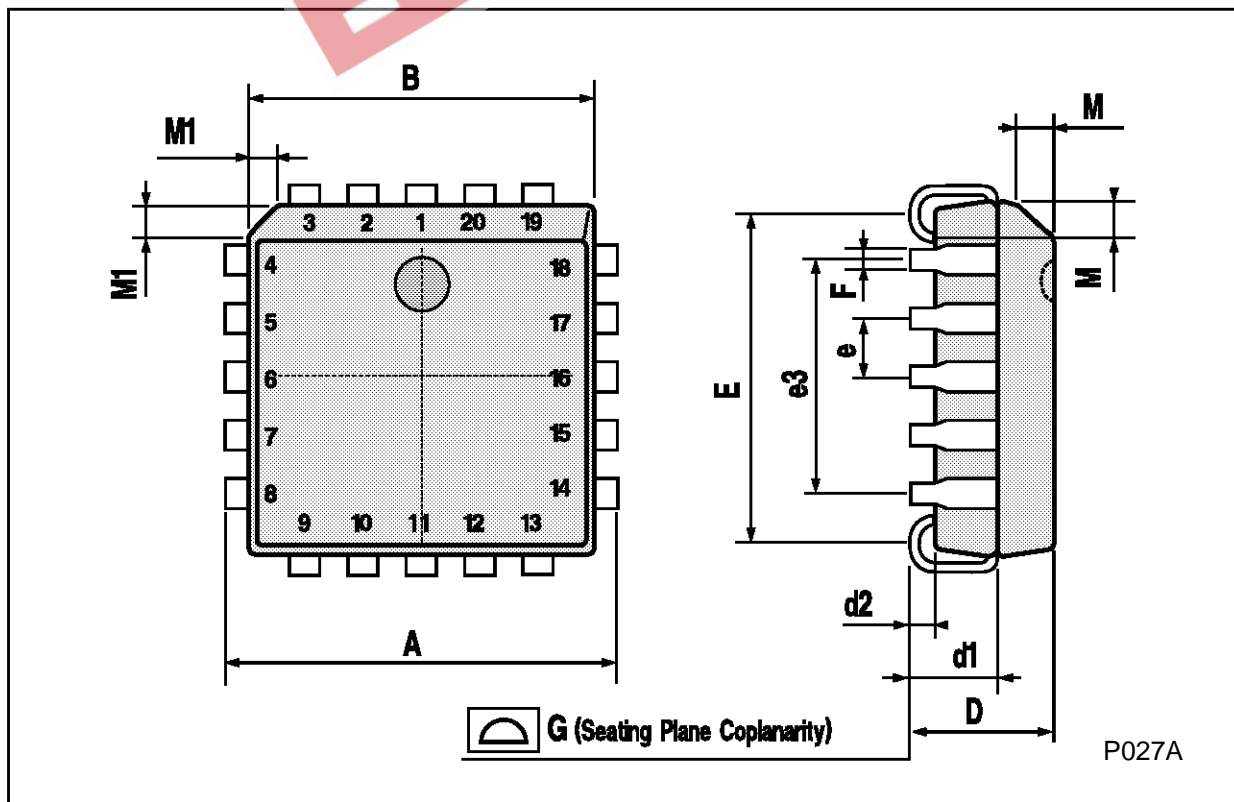

EEPW 电子產品世界  
.com.cn

Information furnished is believed to be accurate and reliable. However, SGS-THOMSON Microelectronics assumes no responsibility for the consequences of use of such information nor for any infringement of patents or other rights of third parties which may result from its use. No license is granted by implication or otherwise under any patent or patent rights of SGS-THOMSON Microelectronics. Specifications mentioned in this publication are subject to change without notice. This publication supersedes and replaces all information previously supplied. SGS-THOMSON Microelectronics products are not authorized for use as critical components in life support devices or systems without express written approval of SGS-THOMSON Microelectronics.

© 1994 SGS-THOMSON Microelectronics - All Rights Reserved

SGS-THOMSON Microelectronics GROUP OF COMPANIES  
Australia - Brazil - France - Germany - Hong Kong - Italy - Japan - Korea - Malaysia - Malta - Morocco - The Netherlands -  
Singapore - Spain - Sweden - Switzerland - Taiwan - Thailand - United Kingdom - U.S.A