

**DUAL 4 INPUT NOR GATE**

- HIGH SPEED  
 $t_{PD} = 10 \text{ ns (TYP.) AT } V_{CC} = 5 \text{ V}$
- LOW POWER DISSIPATION  
 $I_{CC} = 1 \mu\text{A (MAX.) AT } T_A = 25^\circ \text{ C}$
- HIGH NOISE IMMUNITY  
 $V_{NIH} = V_{NIL} = 28 \% V_{CC} \text{ (MIN.)}$
- OUTPUT DRIVE CAPABILITY  
10 LSTTL LOADS
- SYMMETRICAL OUTPUT IMPEDANCE  
 $|I_{OH}| = I_{OL} = 4 \text{ mA (MIN.)}$
- BALANCED PROPAGATION DELAYS  
 $t_{PLH} = t_{PHL}$
- WIDE OPERATING VOLTAGE RANGE  
 $V_{CC} \text{ (OPR)} = 2 \text{ V TO } 6 \text{ V}$
- PIN AND FUNCTION COMPATIBLE WITH 4002B

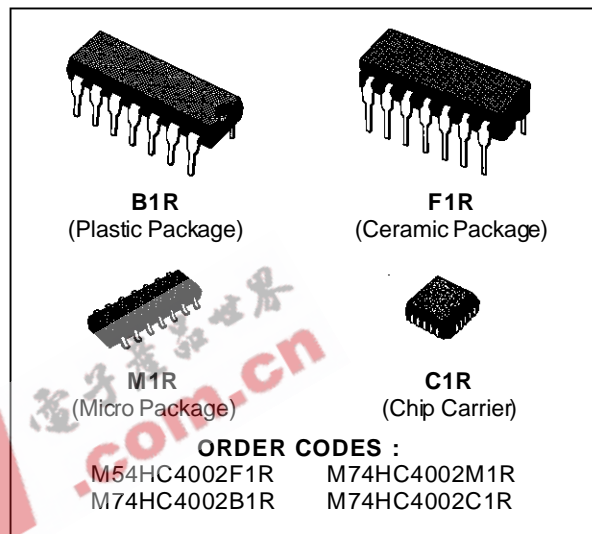

**DESCRIPTION**

The M54/74HC4002 is a high speed CMOS DUAL 4-INPUT NOR GATE fabricated in silicon gate C<sup>2</sup>MOS technology.

It has the same high speed performance of LSTTL combined with true CMOS low power consumption. The internal circuit is composed of 3 stages including buffer output, which ensures high noise immunity and stable output.

All inputs are equipped with protection circuits against static discharge and transient excess voltage.

**INPUT AND OUTPUT EQUIVALENT CIRCUIT**

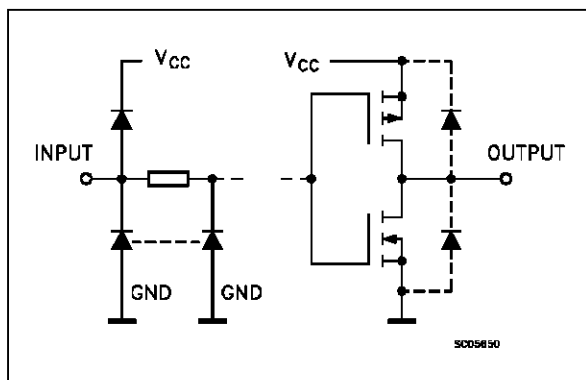

**PIN CONNECTIONS (top view)**

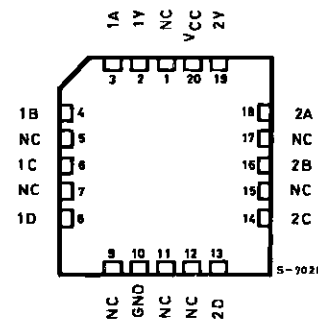
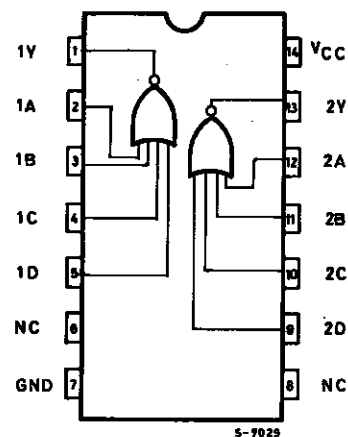

NC =  
No Internal  
Connection

## M54/M74HC4002

### TRUTH TABLE

nA	nB	nC	nD	nY
L	L	L	L	H
H	X	X	X	L
X	H	X	X	L
X	X	H	X	L
X	X	X	H	L

### PIN DESCRIPTION

PIN No	SYMBOL	NAME AND FUNCTION
1, 13	1Y to 2Y	Data Outputs
2, 9	1A to 2A	Data Inputs
3, 10	1B to 2B	Data Inputs
4, 11	1C to 2C	Data Inputs
5, 12	1D to 4D	Data Inputs
6, 8	NC	Not Connected
7	GND	Ground (0V)
14	V <sub>CC</sub>	Positive Supply Voltage

### IEC LOGIC SYMBOL

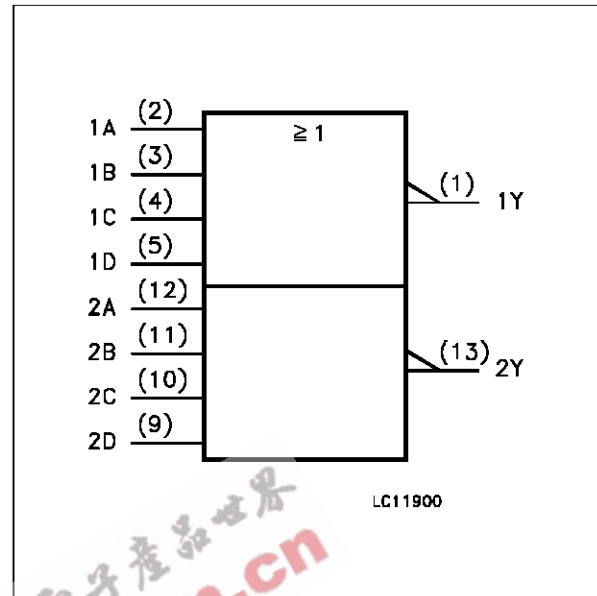

### SCHEMATIC CIRCUIT (Per Gate)

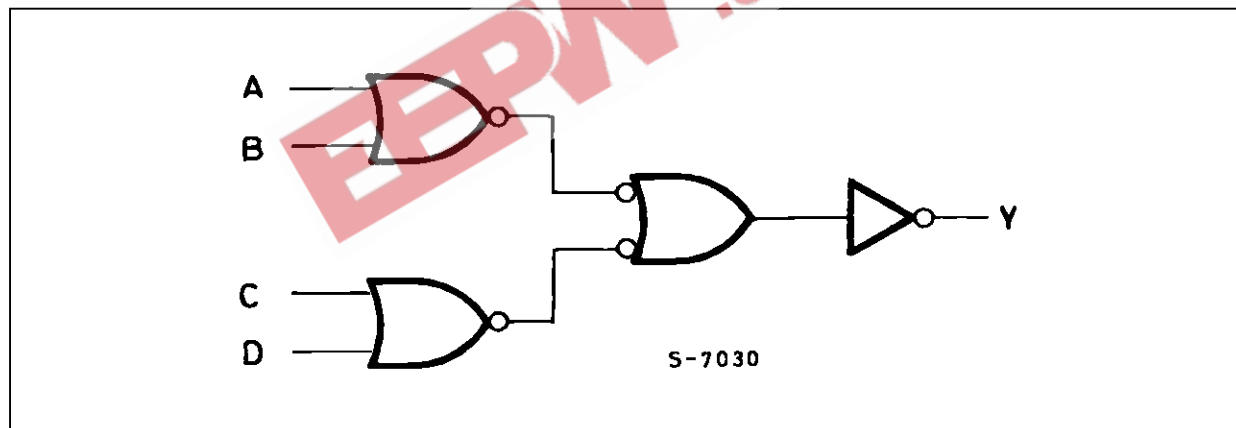

### ABSOLUTE MAXIMUM RATING

Symbol	Parameter	Value	Unit
V <sub>CC</sub>	Supply Voltage	-0.5 to +7	V
V <sub>I</sub>	DC Input Voltage	-0.5 to V <sub>CC</sub> + 0.5	V
V <sub>O</sub>	DC Output Voltage	-0.5 to V <sub>CC</sub> + 0.5	V
I <sub>IK</sub>	DC Input Diode Current	± 20	mA
I <sub>OK</sub>	DC Output Diode Current	± 20	mA
I <sub>O</sub>	DC Output Source Sink Current Per Output Pin	± 25	mA
I <sub>CC</sub> or I <sub>GND</sub>	DC V <sub>CC</sub> or Ground Current	± 50	mA
P <sub>D</sub>	Power Dissipation	500 (*)	mW
T <sub>stg</sub>	Storage Temperature	-65 to +150	°C
T <sub>L</sub>	Lead Temperature (10 sec)	300	°C

Absolute Maximum Ratings are those values beyond which damage to the device may occur. Functional operation under these condition is not implied.  
 (\*) 500 mW: ≅ 65 °C derate to 300 mW by 10mW/°C: 65 °C to 85 °C

## RECOMMENDED OPERATING CONDITIONS

Symbol	Parameter	Value	Unit	
$V_{CC}$	Supply Voltage	2 to 6	V	
$V_I$	Input Voltage	0 to $V_{CC}$	V	
$V_O$	Output Voltage	0 to $V_{CC}$	V	
$T_{op}$	Operating Temperature: <b>M54HC Series</b> <b>M74HC Series</b>	-55 to +125 -40 to +85	°C °C	
$t_r, t_f$	Input Rise and Fall Time	$V_{CC} = 2\text{ V}$ $V_{CC} = 4.5\text{ V}$ $V_{CC} = 6\text{ V}$	0 to 1000 0 to 500 0 to 400	ns

## DC SPECIFICATIONS

Symbol	Parameter	Test Conditions		Value						Unit		
				$T_A = 25\text{ °C}$ 54HC and 74HC			$-40\text{ to }85\text{ °C}$ 74HC		$-55\text{ to }125\text{ °C}$ 54HC			
				Min.	Typ.	Max.	Min.	Max.	Min.		Max.	
$V_{IH}$	High Level Input Voltage	2.0			1.5			1.5		1.5		
		4.5			3.15			3.15		3.15		
		6.0			4.2			4.2		4.2		
$V_{IL}$	Low Level Input Voltage	2.0						0.5		0.5		
		4.5						1.35		1.35		1.35
		6.0						1.8		1.8		1.8
$V_{OH}$	High Level Output Voltage	2.0	$V_I = V_{IH}$ or $V_{IL}$	$I_O = -20\text{ }\mu\text{A}$ or $I_O = -4.0\text{ mA}$ or $I_O = -5.2\text{ mA}$	1.9	2.0		1.9		1.9		
		4.5			4.4	4.5	4.4	4.4	4.4			
		6.0			5.9	6.0	5.9	5.9	5.9			
		4.5			4.18	4.31	4.13	4.10	4.10			
		6.0			5.68	5.8	5.63	5.60	5.60			
$V_{OL}$	Low Level Output Voltage	2.0	$V_I = V_{IH}$ or $V_{IL}$	$I_O = 20\text{ }\mu\text{A}$ or $I_O = 4.0\text{ mA}$ or $I_O = 5.2\text{ mA}$		0.0	0.1		0.1		0.1	
		4.5				0.0	0.1		0.1	0.1		
		6.0				0.0	0.1		0.1	0.1		
		4.5				0.17	0.26		0.33	0.40		
		6.0				0.18	0.26		0.33	0.40		
$I_I$	Input Leakage Current	6.0	$V_I = V_{CC}$ or GND			$\pm 0.1$		$\pm 1$		$\pm 1$	$\mu\text{A}$	
$I_{CC}$	Quiescent Supply Current	6.0	$V_I = V_{CC}$ or GND			1		10		20	$\mu\text{A}$	

## M54/M74HC4002

### AC ELECTRICAL CHARACTERISTICS (C<sub>L</sub> = 50 pF, Input t<sub>r</sub> = t<sub>f</sub> = 6 ns)

Symbol	Parameter	Test Conditions		Value						Unit	
		V <sub>CC</sub> (V)		T <sub>A</sub> = 25 °C 54HC and 74HC			-40 to 85 °C 74HC		-55 to 125 °C 54HC		
				Min.	Typ.	Max.	Min.	Max.	Min.		Max.
t <sub>TLH</sub> t <sub>THL</sub>	Output Transition Time	2.0			30	75		95		110	ns
		4.5			8	15		19		22	
		6.0			7	13		16		19	
t <sub>PLH</sub> t <sub>PHL</sub>	Propagation Delay Time	2.0			48	100		125		150	ns
		4.5			12	20		25		30	
		6.0			10	17		21		26	
C <sub>IN</sub>	Input Capacitance				5	10		10		10	pF
C <sub>PD</sub> (*)	Power Dissipation Capacitance				20						pF

(\*) C<sub>PD</sub> is defined as the value of the IC's internal equivalent capacitance which is calculated from the operating current consumption without load. (Refer to Test Circuit). Average operating current can be obtained by the following equation. I<sub>CC(OPR)</sub> = C<sub>PD</sub> • V<sub>CC</sub> • f<sub>IN</sub> + I<sub>CC</sub>/4 (per Gate)

### SWITCHING CHARACTERISTICS TEST CIRCUIT

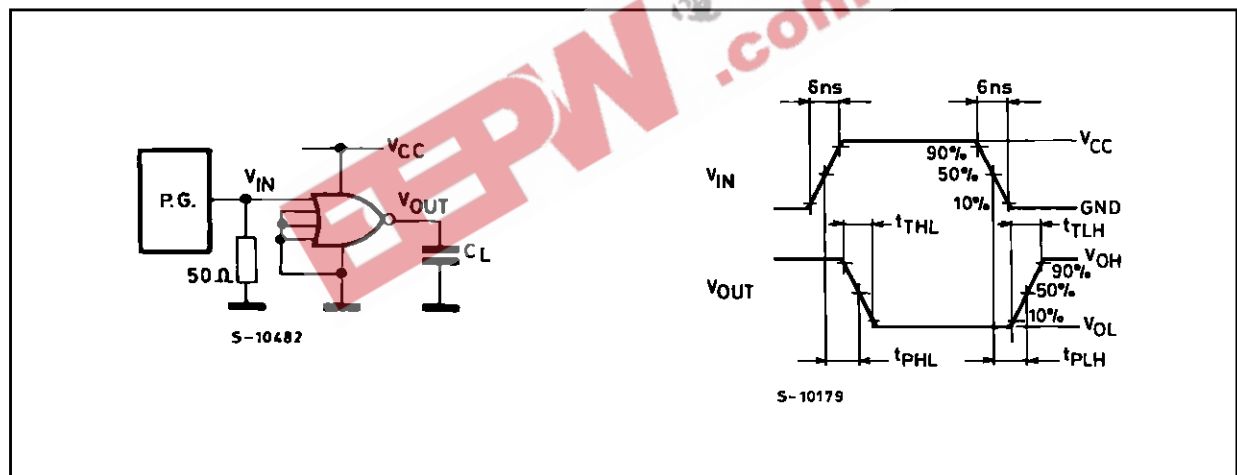

### TEST CIRCUIT I<sub>CC</sub> (Opr.)

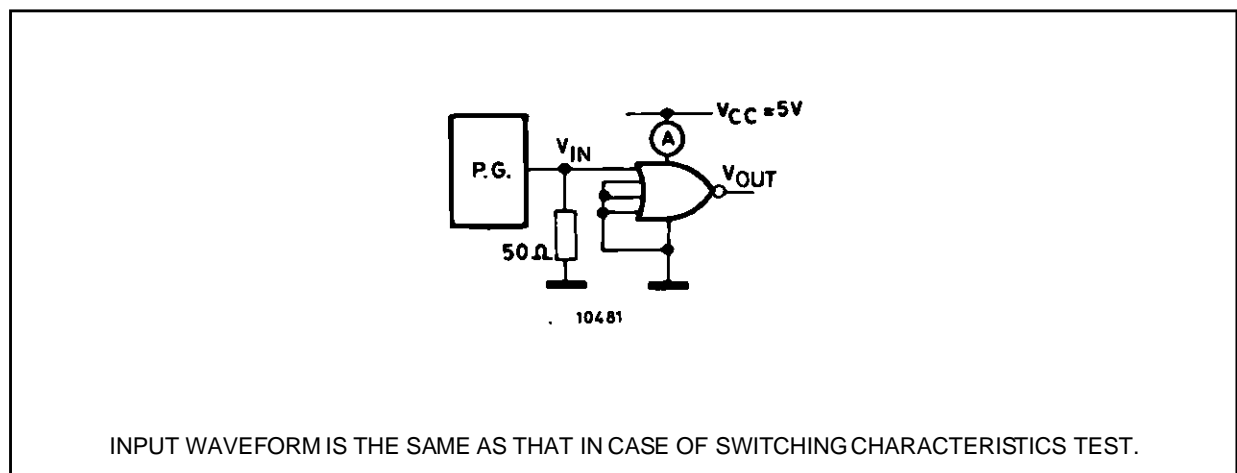

## Plastic DIP14 MECHANICAL DATA

DIM.	mm			inch		
	MIN.	TYP.	MAX.	MIN.	TYP.	MAX.
a1	0.51			0.020		
B	1.39		1.65	0.055		0.065
b		0.5			0.020	
b1		0.25			0.010	
D			20			0.787
E		8.5			0.335	
e		2.54			0.100	
e3		15.24			0.600	
F			7.1			0.280
I			5.1			0.201
L		3.3			0.130	
Z	1.27		2.54	0.050		0.100

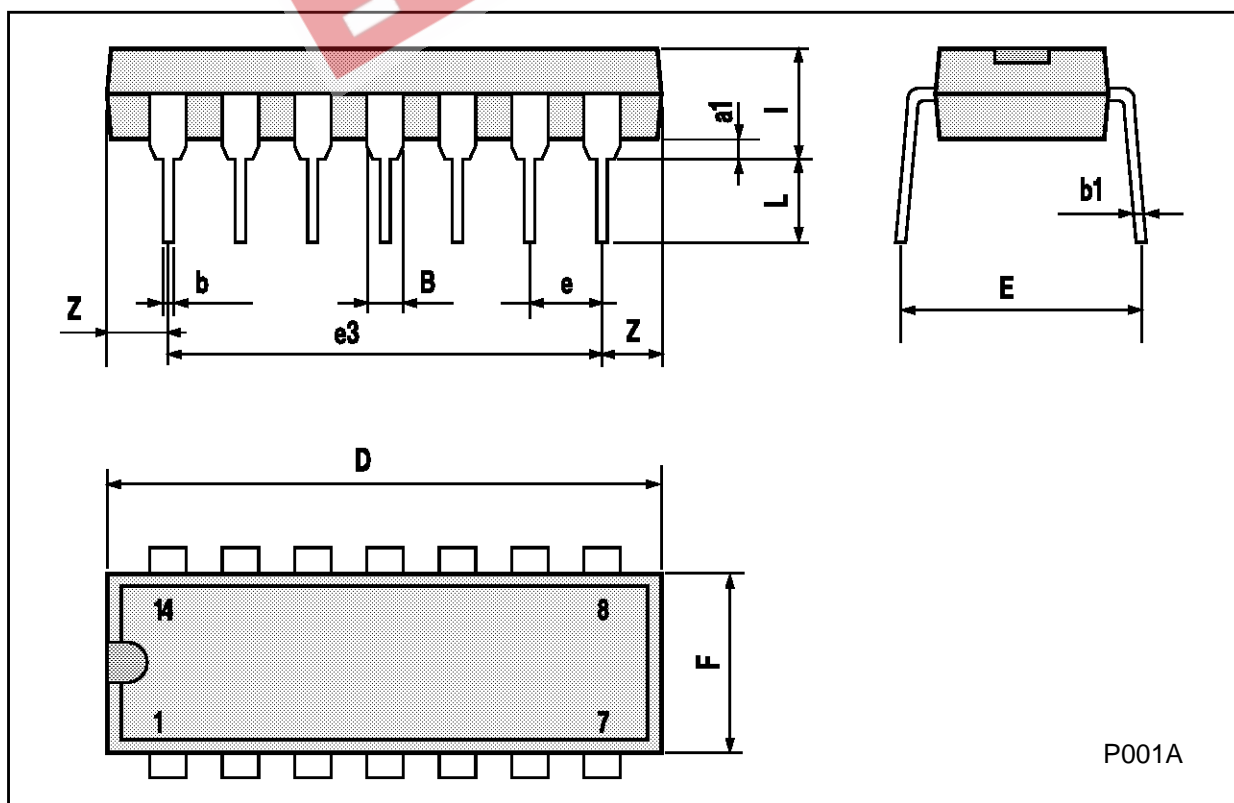

M54/M74HC4002

**Ceramic DIP14/1 MECHANICAL DATA**

DIM.	mm			inch		
	MIN.	TYP.	MAX.	MIN.	TYP.	MAX.
A			20			0.787
B			7.0			0.276
D		3.3			0.130	
E	0.38			0.015		
e3		15.24			0.600	
F	2.29		2.79	0.090		0.110
G	0.4		0.55	0.016		0.022
H	1.17		1.52	0.046		0.060
L	0.22		0.31	0.009		0.012
M	1.52		2.54	0.060		0.100
N			10.3			0.406
P	7.8		8.05	0.307		0.317
Q			5.08			0.200

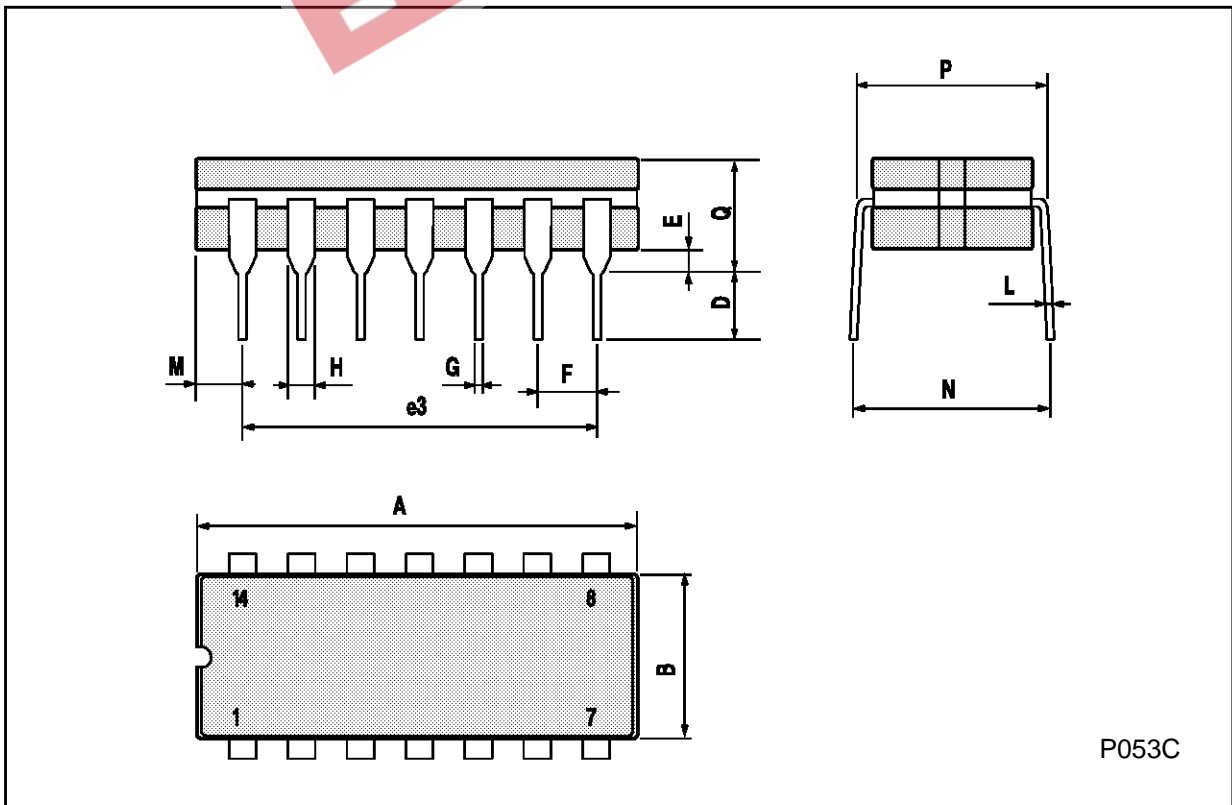

## SO14 MECHANICAL DATA

DIM.	mm			inch		
	MIN.	TYP.	MAX.	MIN.	TYP.	MAX.
A			1.75			0.068
a1	0.1		0.2	0.003		0.007
a2			1.65			0.064
b	0.35		0.46	0.013		0.018
b1	0.19		0.25	0.007		0.010
C		0.5			0.019	
c1	45° (typ.)					
D	8.55		8.75	0.336		0.344
E	5.8		6.2	0.228		0.244
e		1.27			0.050	
e3		7.62			0.300	
F	3.8		4.0	0.149		0.157
G	4.6		5.3	0.181		0.208
L	0.5		1.27	0.019		0.050
M			0.68			0.026
S	8° (max.)					

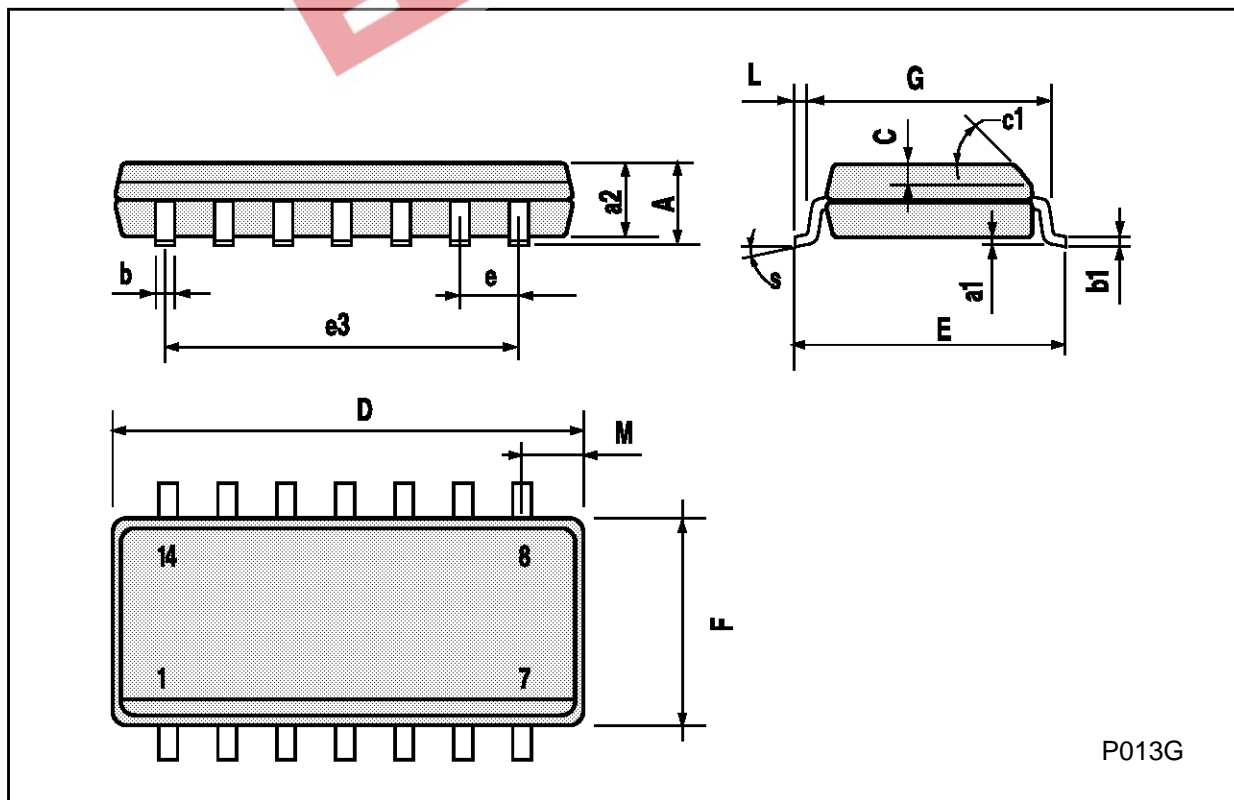

**PLCC20 MECHANICAL DATA**

DIM.	mm			inch		
	MIN.	TYP.	MAX.	MIN.	TYP.	MAX.
A	9.78		10.03	0.385		0.395
B	8.89		9.04	0.350		0.356
D	4.2		4.57	0.165		0.180
d1		2.54			0.100	
d2		0.56			0.022	
E	7.37		8.38	0.290		0.330
e		1.27			0.050	
e3		5.08			0.200	
F		0.38			0.015	
G			0.101			0.004
M		1.27			0.050	
M1		1.14			0.045	

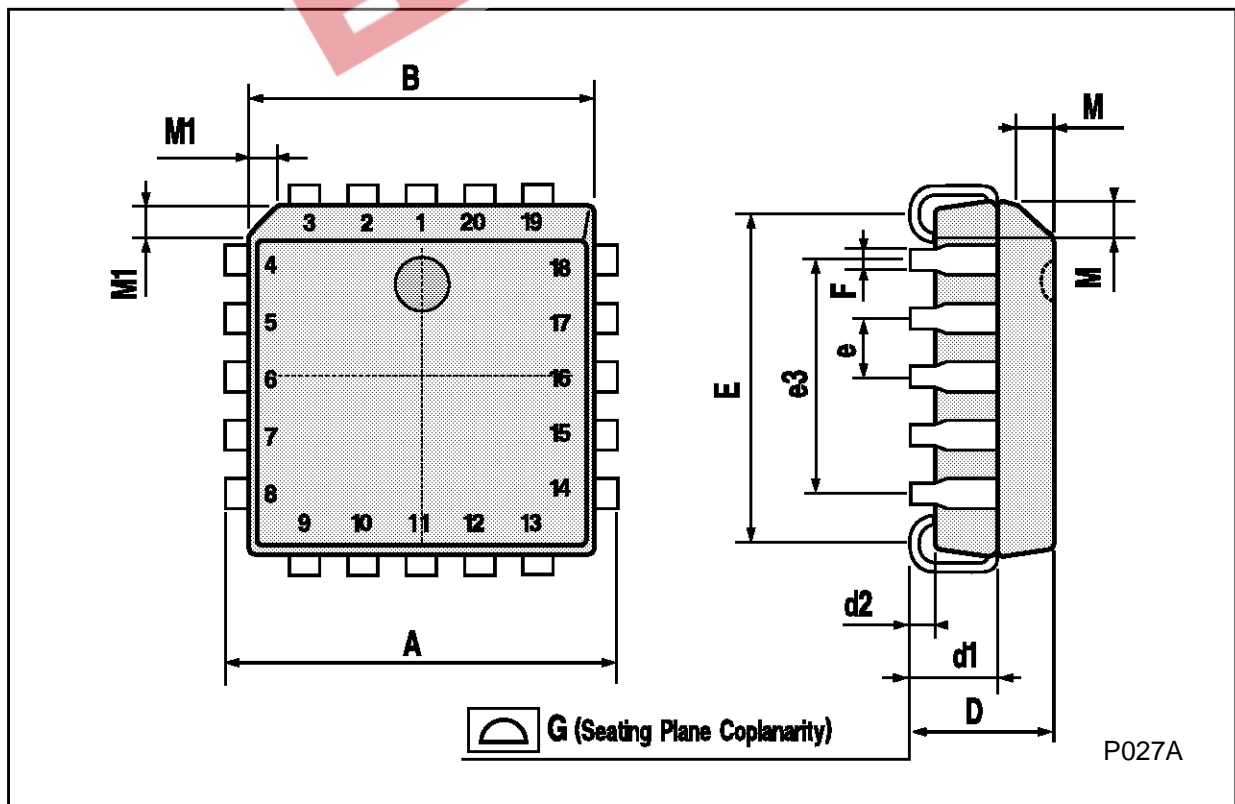



EEPW 电子產品世界  
.com.cn

Information furnished is believed to be accurate and reliable. However, SGS-THOMSON Microelectronics assumes no responsibility for the consequences of use of such information nor for any infringement of patents or other rights of third parties which may result from its use. No license is granted by implication or otherwise under any patent or patent rights of SGS-THOMSON Microelectronics. Specifications mentioned in this publication are subject to change without notice. This publication supersedes and replaces all information previously supplied. SGS-THOMSON Microelectronics products are not authorized for use as critical components in life support devices or systems without express written approval of SGS-THOMSON Microelectronics.

© 1994 SGS-THOMSON Microelectronics - All Rights Reserved

SGS-THOMSON Microelectronics GROUP OF COMPANIES

Australia - Brazil - France - Germany - Hong Kong - Italy - Japan - Korea - Malaysia - Malta - Morocco - The Netherlands -  
Singapore - Spain - Sweden - Switzerland - Taiwan - Thailand - United Kingdom - U.S.A